



COLORADO
Department of Transportation



Pedestrian Pushbutton Measurement Guide

Version 1.0 – January 2020

Table of Contents

Pedestrian Pushbutton Measurement Guide

<u>Purpose of the Pedestrian Pushbutton Measurement Guide</u>	<u>3</u>
<u>Accessible Pedestrian Pushbutton (APB) Background</u>	<u>4</u>
<u>General APB Measurements</u>	<u>5-14</u>

Disclaimer:

The information contained in this document does not constitute a CDOT standard and shall be for reference only. This document is to be used in conjunction with existing CDOT design and construction standards.

Purpose of the Pedestrian Pushbutton Measurement Guide

General Notes

- The purpose of the Pedestrian Push Button Measurement Guide is to standardize the process for collecting pedestrian push button information to evaluate accessibility.
- It is the responsibility of the engineer, contractor, or inspector to understand the applicable MUTCD, CDOT, and PROWAG guidelines as they relate to pedestrian push buttons.
- All slope measurements are recorded as a percentage to one decimal place (i.e. 1.7% slope)
- All distance measurements are recorded to the nearest inch (i.e. 49 IN. all-weather surface width)

Required Measuring Equipment

- Metal measuring tape with a minimum length of 25'. Measurements shall be taken to the nearest inch.

Additional CDOT Pedestrian Push Button Resources

<https://www.codot.gov/business/civilrights/ada/resources-engineers>

<https://www.access-board.gov/research/prow/common-problems-aps-installation/introduction/>

Accessible Pedestrian Pushbutton (APB) Background

What is an accessible pedestrian signal and pushbutton?

- “An accessible pedestrian signal and pedestrian pushbutton is an integrated device that communicates information about the WALK and DON’T WALK intervals at signalized intersections in non-visual formats (i.e., audible tones and vibrotactile surfaces) to pedestrians who are blind or have low vision. The pedestrian pushbutton has a locator tone for detecting the device and a tactile arrow to indicate which pedestrian street crossing is served by the device.”

What do PROWAG and the MUTCD say about these devices?

- Pedestrian Push Button (PPB) requirements are found within the Manual on Uniform Traffic Control Devices (MUTCD) and the Public Rights-of-Way Accessibility Guidelines (PROWAG). The MUTCD has standards for accessible pedestrian pushbuttons and signals, but does not require them to be provided. PROWAG requires accessible pedestrian pushbuttons and signals to be provided when new pedestrian signals are installed.
- “For existing pedestrian signals, the proposed guidelines are required to be provided when the signal controller and software are altered, or the signal head is replaced. Accessible pedestrian signals and pedestrian pushbuttons must comply with the referenced standards in the MUTCD and the technical requirements for operable parts in Chapter R4 [in PROWAG].”
 - PROWAG R209

Is there a pedestrian pushbutton present?

Pedestrian Pushbutton Measurement Guide

Does this curb ramp serve a pedestrian crossing where the crossing is controlled by a pedestrian signal?

- Pedestrian pushbuttons come in different shapes and sizes. Some may be located on the signal column or they may have a separate post assembly. Pushbuttons are located at varying locations at an intersection corner.



Does the “Walk” signal require you to press the push button?

Is the use of a push button required to activate the “Walk” Signal?

- Some crossings do not require the pedestrian to press a pushbutton for the walk signal to be activated.
 - The signal may be equipped with passive detection where a piece of equipment detects pedestrians or
 - other crossings automatically include a walk phase into the signals and do not require a button to be pressed to initiate a walking phase.
- If the pedestrian crossing does not require you to activate with the push of the button, select “no” in the Survey 123 application.
- If you are required to press a button, select “yes” in the Survey 123 application.



Photo: James Wagner

PPB Location

Pedestrian Pushbutton Measurement Guide

The MUTCD requires the PPB to be located within a certain range of dimensions at an intersection. To better explain where the pushbutton needs to be, MUTCD created the image to the right.

- Is the PPB located within the recommended area for pushbutton locations?

Figure 4E-3. Pushbutton Location Area

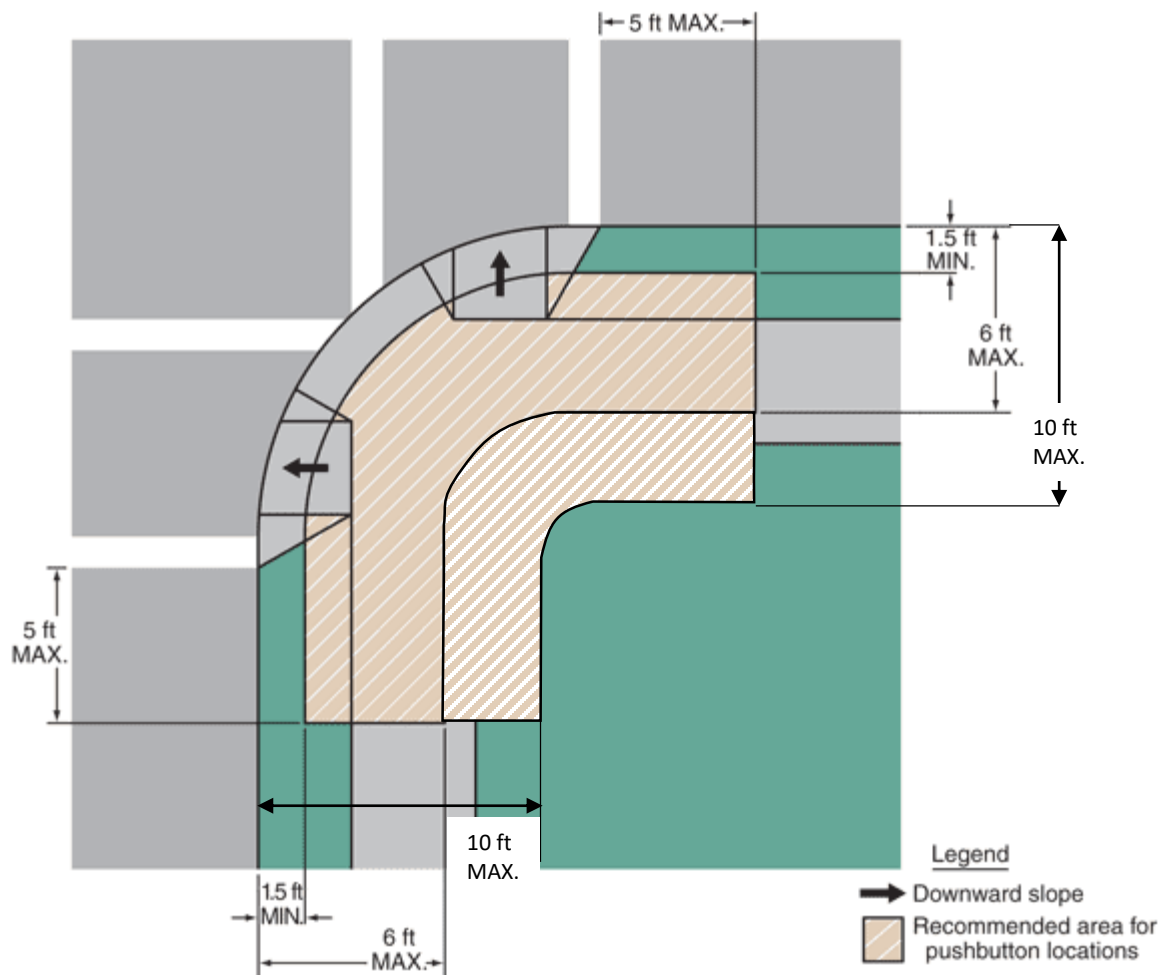

Notes:

1. Where there are constraints that make it impractical to place the pedestrian pushbutton between 1.5 feet and 6 feet from the edge of the curb, shoulder, or pavement, it should not be further than 10 feet from the edge of curb, shoulder, or pavement.
2. Two pedestrian pushbuttons on a corner should be separated by 10 feet.
3. This figure is not drawn to scale.
4. Figure 4E-4 shows typical pushbutton locations.

PPB Landing Adjacent

Pedestrian Pushbutton Measurement Guide

PROWAG requires that an all weather surface must be provided adjacent to the pedestrian pushbutton. The landing must be a minimum 48" x 48" and be a concrete, asphalt, or similar all-weather surface. Grades of the landing must be consistent with the grades of the adjacent pedestrian access route.

- Is the PPB unobstructed and adjacent to a 48" x 48" all-weather surface?



Pedestrian Pushbutton Measurement Guide

Accessible Route

- Is there a wheelchair accessible route from the PPB to the curb ramp?



Pedestrian Pushbutton Measurement Guide

- Is the side reach from the edge of sidewalk (or level all-weather surface) to the PPB greater than 10 inches?

Side Reach Diagram

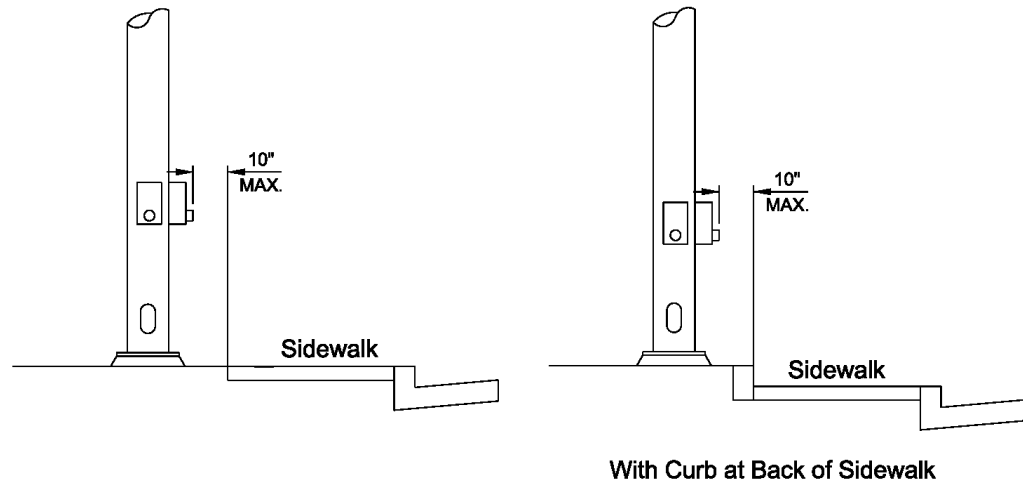

Mounting Height

Pedestrian Pushbutton Measurement Guide

- Is the PPB mounted at a height of between 42 and 48 inches above the finished surface?

Mounting Height Diagram

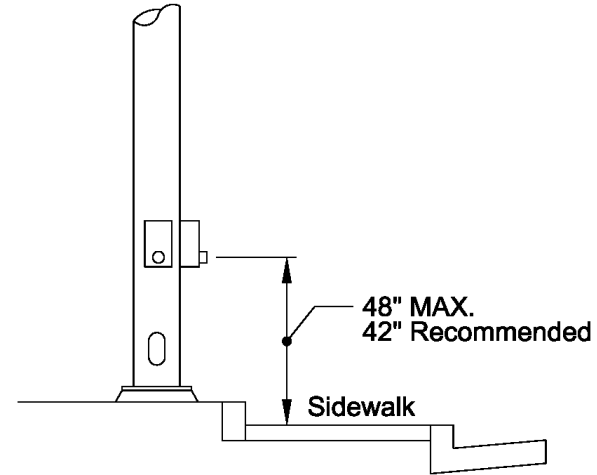

PPB Type

Pedestrian Pushbutton Measurement Guide

- Is the PPB closed fist or finger push activated?



Closed Fist Activated



Finger Push Activated

Pedestrian Pushbutton Measurement Guide

- Does the PPB make noise during the WALK indication (often times a ticking, cuckoo-cheep, or speech message)?
- Does the PPB vibrate during the WALK indication (vibrotactile)?



Image of a vibrotactile and audible pedestrian pushbutton

Image from AER – Association for Education and Rehabilitation of the Blind and Visually Impaired

PPB Separation

Pedestrian Pushbutton Measurement Guide

- If two pushbuttons are located at an intersection corner, they should be separated by a distance of at least 10 feet (120 inches).

Ideal placement

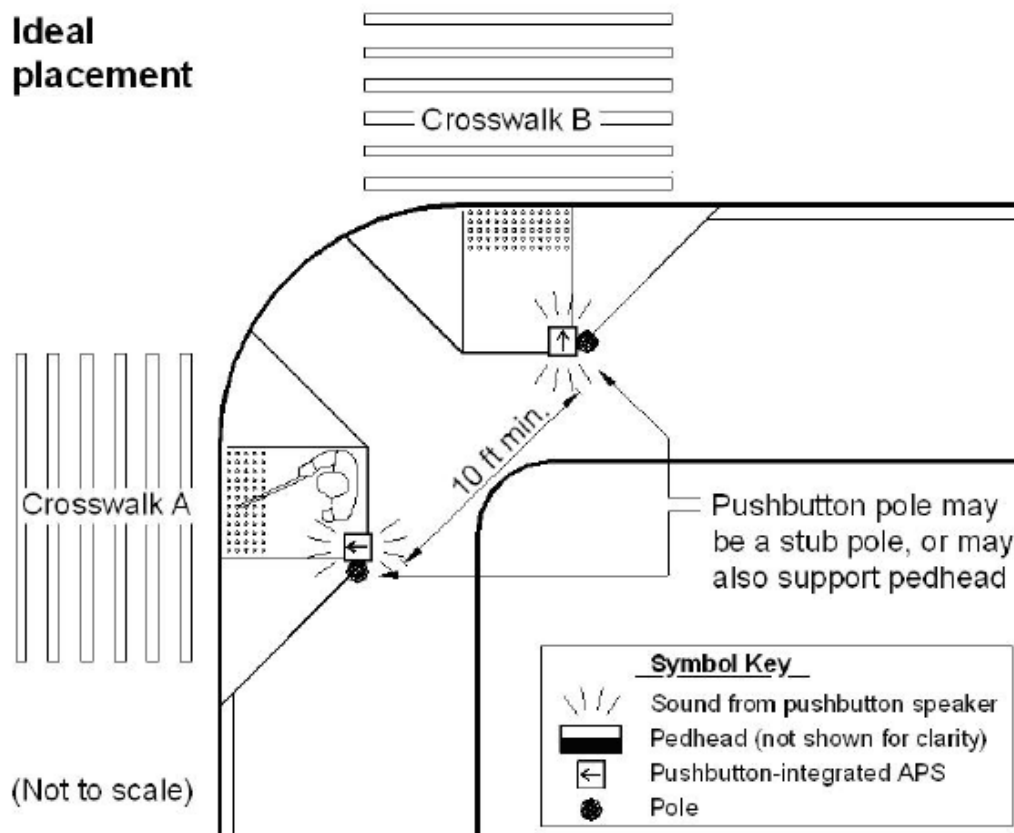

Figure 6-37. Ideal placement for pushbutton-integrated APS.