

SEE STANDARD M-100-A FOR STANDARD SYMBOLS

STATE DEPARTMENT OF HIGHWAYS DIVISION OF HIGHWAYS—STATE OF COLORADO

FEDERAL ROAD DIST. NO.	DIVISION	PROJECT NO.	SHEET NO.
VIII	COLORADO	I 70-2(68)197	1
AS CONSTRUCTED			
NO REVISIONS		REVISED <u>6-12-78</u>	VOID

P.E., R.O.W. and Utilities under Project No. I 70-2(38)

PLAN AND PROFILE OF PROPOSED FEDERAL AID PROJECT NO. I 70-2(68)197 STATE HIGHWAY NO. 70 SUMMIT COUNTY

LARGE
DUPLICATE
ON
RACK

SCALES OF ORIGINAL DRAWINGS
ON PLAN 1 IN = 100 FT
ON PROFILE 1 IN = 100 FT HORIZONTAL
1 IN = 10 FT VERTICAL
GRADE LINE ON PROFILE IS SHOWN AS GRADE OF FINISHED RECREATION TRAIL
GROSS LENGTH OF PROJECT — NO CENTER LINE LENGTH
NET LENGTH OF PROJECT

INDEX OF SHEETS

SHEET NO.	DESCRIPTION	REVISIONS
1	TITLE SHEET AND SKETCH MAP	
2	TYPICAL SECTION AND GENERAL NOTES	
3	SUMMARY OF APPROXIMATE QUANTITIES	
4-5	STRUCTURE QUANTITIES	
6	DETAILS OF TYPICAL CHANNEL CHANGE	
7	DETAILS OF ROCK DAM, FELLED TREE WITH ANCHOR, ROCK DEFLECTOR AND LOG DEFLECTOR	
8	DETAILS OF ROCK WALL AND TIMBER CRIB WALL	
9-15	DETAILS OF STRUCTURE NUMBERS F-12-AZ, BA, BB, BC AND BD	
16-31	ALIGNMENT PLAN AND PROFILE SHEETS	

"NO REVISIONS" Sheet No's 6-8, 10, 15, 17, 19, 21, 23, 25, 27, 29, 31

STANDARDS

M-100-A	STANDARD SYMBOLS	5-11-73
M-107-A	TEMPORARY EROSION CONTROL	4-21-75
M-203-C	DITCH TYPES	7-23-68
M-203-SC	SUPERELEVATION OF CURVES - CROWNED HIGHWAYS	1-06-77
M-206-AB	EXCAVATION AND BACKFILL FOR STRUCTURES	(3 SHEETS) 4-16-76
M-214-A	PLANTING DETAILS	1-21-75
M-500-A	LETTERS AND FIGURES FOR STRUCTURE NUMBERS	3-28-75
M-603-CA	CONCRETE AND METAL END SECTIONS	8-21-75
M-603-MA	METAL CULVERT PIPE - H-20 LOADING	8-20-75
M-614-TB	TRAFFIC SIGNING FOR HIGHWAY CONSTRUCTION	(3 SHEETS) 11-22-71
S-614-52A	BARRICADES, DRUMS AND VERTICAL PANEL CHANNELIZING DEVICES	12-04-74

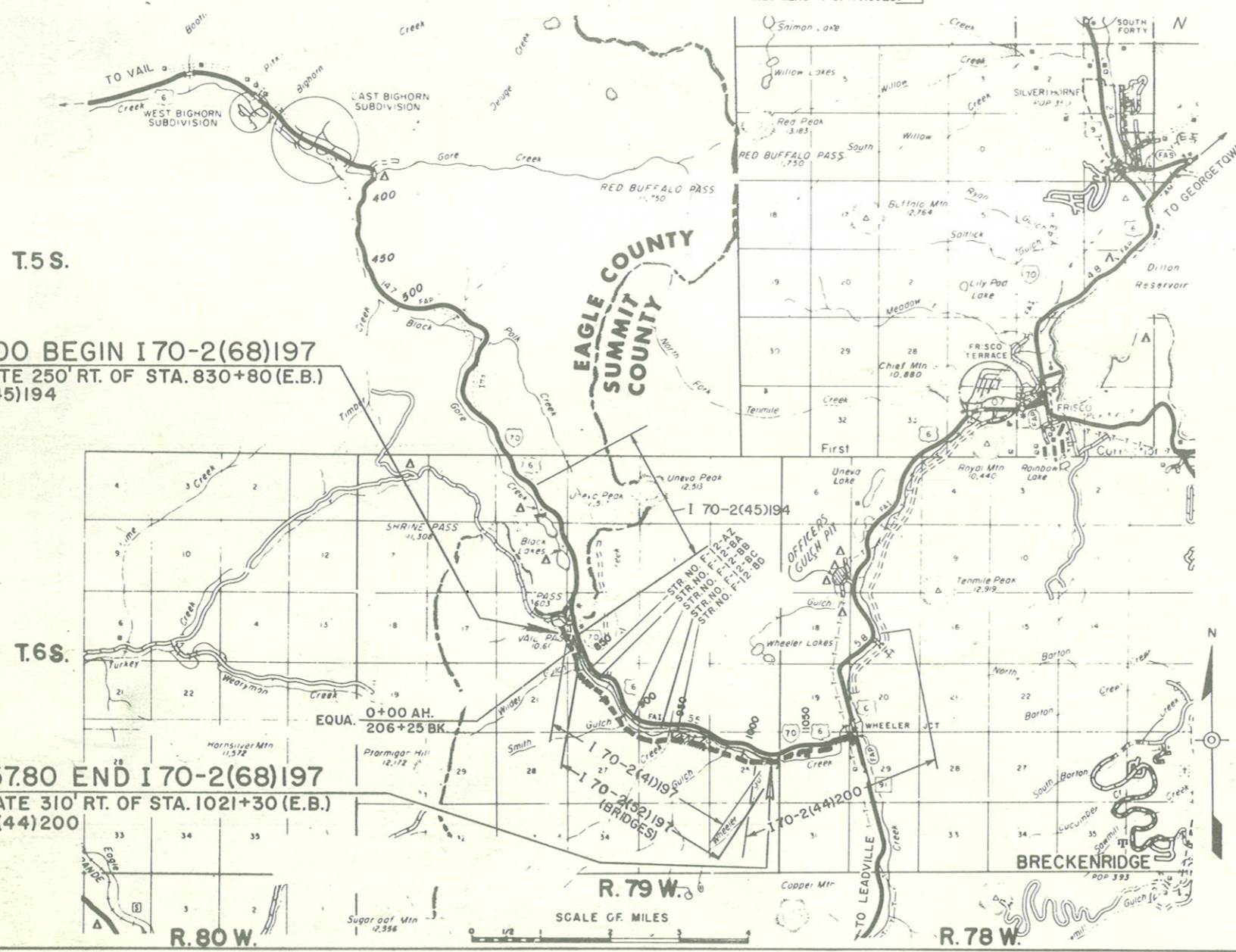

STA. 200+00 BEGIN I 70-2(68)197
APPROXIMATE 250' RT. OF STA. 830+80 (E.B.)
ON I 70-2(45)194

STA. 194+57.80 END I 70-2(68)197
APPROXIMATE 310' RT. OF STA. 1021+30 (E.B.)
ON I 70-2(44)200

SCALE OF MILES
0 1/2 1 2

AS CONSTRUCTED INFORMATION

CONTRACTOR	Herron-Strong, Inc
Project ENGINEER (Project or Resident)	R.C. YOWELL
PROJECT STARTED	June 6, 1977
PROJECT COMPLETED	June 13, 1978
AS CONSTRUCTED PLANS APPROVED	A.R. Ursone by Gary A. Disinger
Const. Engr. TITLE	10-24-78 DATE

DIVISION OF HIGHWAYS

APPROVED

Tom M. Cox 4/1/77
ASST. CHIEF ENGINEER DATE

DEPARTMENT OF TRANSPORTATION
FEDERAL HIGHWAY ADMINISTRATION

APPROVED _____ DATE _____

DIVISION ADMINISTRATOR

W.C.B.

FEDERAL ROAD REGION NO.	DIVISION	PROJ. NO.	SHEET NO.	TOTAL SHEETS
VIII	COLORADO	I 70-2(68)197	2	31

AS CONSTRUCTED
 NO REVISIONS REVISED 6-13-78 VOID

(R-1) 4-25-77, Typical, WCB

TYPICAL SECTION

(R-1)

GENERAL NOTES

FOR PRELIMINARY PLAN QUANTITIES OF BITUMINOUS MATERIALS, THE FOLLOWING RATES OF APPLICATION WERE USED:

PRIME COAT (MC-70) @ 0.20 GALS. PER SQ. YD.

RATES OF APPLICATION SHALL BE AS DETERMINED BY THE ENGINEER AT THE TIME OF APPLICATION.

771

IT IS ESTIMATED THAT ~~4000~~ HOURS OF FLAGGING FOR CONTROLLING TRAFFIC WILL BE REQUIRED FOR THIS PROJECT.

THE MINIMUM THICKNESS OF TOPSOIL SHALL BE 4 INCHES. IT IS ESTIMATED THAT 1,300 CU. YDS. WILL BE REQUIRED AND WILL BE OBTAINED FROM STOCKPILE LEFT OF STA. 120+. PLACEMENT OF TOPSOIL WILL BE PAID FOR BY THE NUMBER OF EQUIPMENT HOURS USED.

SEEDING, SOIL PREPARATION, FERTILIZING WITH COMMERCIAL FERTILIZER, AND MULCHING FOR APPROXIMATELY 4 ACRES WILL BE REQUIRED ON ALL DISTURBED AREAS. THE FOLLOWING TYPES AND RATES SHALL BE USED:

COMMON NAME	BOTANICAL NAME	PERCENT PURITY	PERCENT GERMINATION	RATE PLS/ACRE
STREAMBANK WHEATGRASS	AGROPYRON RIPARIUM	97	92	7
WESTERN WHEATGRASS	AGROPYRON SMITHII	85	70	4
KENTUCKY BLUEGRASS	POA PRATENSIS	85	75	3
SMOOTH BROME (MANCHAR)	BROMUS INERMIS	85	80	5
TIMOTHY	PHLEUM PRATENSE	99	90	4
RED FESCUE	FESTUCA RUBRA	98	85	3
MEADOW FOXTAIL	ALOPECURUS PRATENSIS	95	80	4
SLENDER WHEATGRASS	AGROPYRON PAUCIFLORUM	90	85	5
WHITE DUTCH CLOVER	TRIFOLIUM REPENS	98-1/2	90	2
ALSIKE CLOVER	TRIFOLIUM HYBRIDUM	98-1/2	90	3
TOTAL PLS/ACRE SEEDING				40

COMMERCIAL FERTILIZER	PERCENT AVAILABLE	LBS/ACRE AVAILABLE NITROGEN	AVAILABLE SUPERPHOSPHATE	RATE LBS/ACRE
AVAILABLE NITROGEN (18-0-0)	18	50		278
AVAILABLE SUPERPHOSPHATE (0-45-0)	45		100	222
TOTAL LBS/ACRE				500

MULCHING (NATIVE HAY) 2 TONS PER ACRE

ROADBED SHALL BE WIDENED AT BRIDGE APPROACHES AND WHERE DIRECTED.

IT IS ESTIMATED THAT THE FOLLOWING WILL BE REQUIRED ON THIS PROJECT:

ITEM	HOURS
BLADING (180 TO 250 HORSEPOWER RANGE)	400 369.5
DOZING (LANDSCAPING) (50 TO 105 HORSEPOWER RANGE)	150 200
DOZING (120 TO 220 HORSEPOWER RANGE)	600 809
DOZING (HEAVY) (270 TO 400 HORSEPOWER RANGE)	500 549.5
TRUCK (OFF HIGHWAY END DUMP)	750 687
TRUCK (DUMP)	700 1019
FRONT END LOADER (RUBBER TIRE)	500 591.5
FRONT END LOADER	300 302
COMBINATION LOADER	300 285

EACH CRAWLER-TYPE TRACTOR FURNISHED SHALL BE EQUIPPED WITH POWER UNIT RIPPER AND BULLDOZER BLADE. BLADE WIDTH SHALL NOT EXCEED 12 FEET.

PAVING, FINAL GRADING, LANDSCAPING AND SEEDING SHALL BE DONE ON A FUTURE PROJECT.

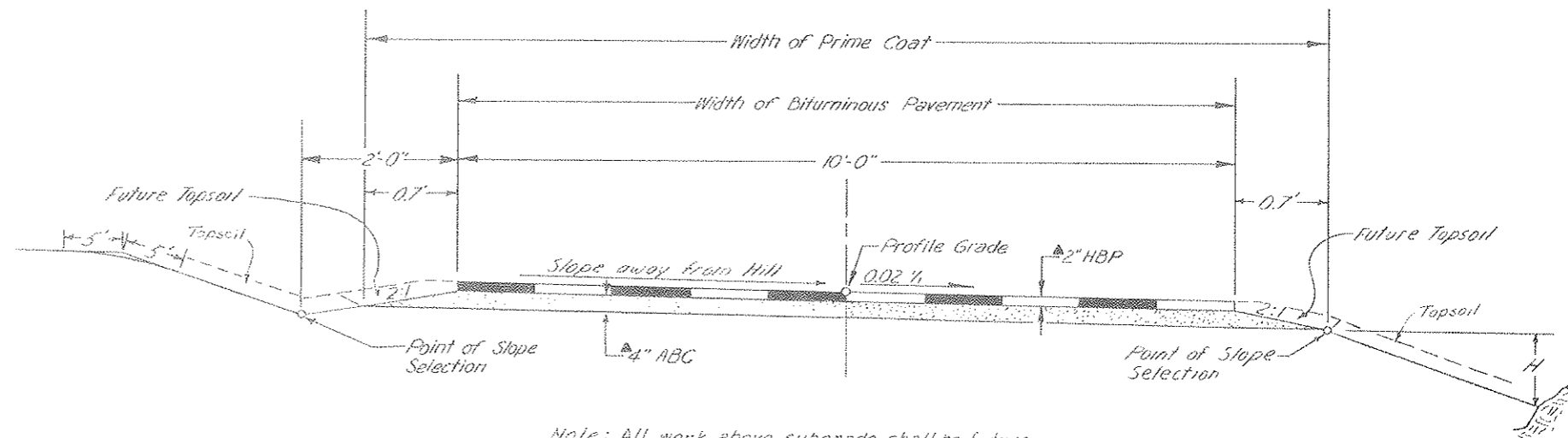

CUT SLOPE	
H	Slope
0' to 4.0'	4:1
4.0' to 6.0'	3:1
6.0' to 30.0'	2:1
Over 30.0'	1 1/2:1

Slopes may be steepened in special cases.

Note: All work above subgrade shall be future construction

In some areas roadbed will be rough graded only. Final grading will be completed on a future project.

▲ Approximate Thickness

FILL SLOPE	
H	Slope
0' to 6.0'	3:1
6' to 30.0'	2:1
over 30.0'	1 1/4:1

Slopes may be steepened in special cases

FINAL
SUMMARY OF APPROXIMATE QUANTITIES

AS CONSTRUCTED

NO REVISIONS REVISED 12/28 VOID

FEDERAL ROAD DISTRICT NO.	DIVISION	PROJ. NO.	SHEET NO.	TOTAL SHEETS
111E	COLORADO	170-2(68)197	3	31

INDEX			CONTRACT ITEM NO.	CONTRACT ITEM	UNIT	MAJOR STR. NO. F-12-AZ	MAJOR STR. NO. F-12-BA	MAJOR STR. NO. F-12-BB	MAJOR STR. NO. F-12-BC	MAJOR STR. NO. F-12-BD	ROADWAY	FINAL ROADWAY	PROJECT TOTALS	FINAL TOTALS	+ or -	%
BOOK	PAGE	SHEET														
3	46		201	Clearing & Grubbing	L. S.						1	1	1	1	0	100%
1	9	4	202	Removal of Structure C 110 1071	Each						1	0	1	0	-1	0%
DoH Form No 7			203	Blading C.C. 1068	Hour						400	369 1/2	400	369 1/2	-30 1/2	92%
DoH Form No 7			203	Dozing	Hour						600	809	600	809	+209	135%
DoH Form No 7			203	Dozing (Heavy)	Hour						500	558.5	500	558.5	+58.5	112%
DoH Form No 7			203	Dozing (Landscaping)	Hour						150	200	150	200	+50	133%
DoH Form No 7			203	Truck (Off Highway End Dump) C 1068	Hour						750	687	750	687	-63	92%
DoH Form No 7			203	Truck (Dump)	Hour						700	1,019	700	1,019	+319	146%
DoH Form No 7			203	Front End Loader (Rubber Tired)	Hour						500	591 1/2	500	591 1/2	+91 1/2	118%
DoH Form No 7			203	Front End Loader	Hour						300	302	300	302	+2	101%
DoH Form No 7			203	Combination Loader	Hour						300	285	300	285	-15	95%
2	32	5	206	Structure Excavation	Cu. Yd.	55	40	50	50	50	615	1250	860	1495	+635	174%
2	32	5	206	Structure Backfill (Class 2)	Cu. Yd.	20	10	15	10	10	965	421	1030	486	-544	47%
2	32	5	206	Filter Material (Class A)	Cu. Yd.						300	765	300	765	+465	255%
2	32	5	209	Water (Landscaping) Deleted C 110 1071	M. Gal.						100	0	100	0	-100	0%
2	32	4	210	Reset End Section	Each						1	1	1	1	0	100%
3	7		212	Seeding (Native)	Lb.						160	671	160	671	+511	417%
3	7		212	Fertilizer	Lb.						2000	8385	2000	8385	+6385	417%
3	7		212	Soil Preparation (Native) C 110 1071	Acre						4	0	4	0	-4	-
3	7		213	Mulching	Ton						8	33.54	8	33.54	+25.54	417%
3	45		411	Liquid Asphaltic Material (MC 70)	Gal.						6000	5726	6000	5726	-274	95%
2	7	5	504	Place Timber Cribbing	Sq. Ft.						3000	560	3000	560	-2440	19%
2	32		506	Riprap	Cu. Yd.	3024	3023	30	3020	3015			150	112	-38	75%
2	32		508	Treated Timber	MFBM	2.66	2.66	4.05	6.81	4.90			21.08	21.08	0	100%
2	32		601	Concrete Class A (Bridge)	Cu. Yd.	6	4	5	3	4			22	22	0	100%
2	32		602	Reinforcing Steel	Lb.	440	270	350	270	290			1620	1620	0	100%
2	31	5	603	24 Inch Corrugated Steel Pipe	Lin. Ft.						736	822	736	822	+86	112%
2	31	5	603	42 Inch Corrugated Steel Pipe	Lin. Ft.						54	54	54	54	0	100%
2	31	5	603	24 Inch Steel End Section	Each						53	57	53	57	+4	108%
2	31	5	603	42 Inch Steel End Section	Each						3	3	3	3	0	100%
2	31	5	605	6 Inch Perforated Corrugated Steel Pipe	Lin. Ft.						800	2200	800	2200	1400	275%
DoH Form No 7			614	Flagging	Hour						1000	771	1000	771	-229	77%
3	47		620	Field Laboratory	Each						1	1	1	1	0	100%
3	47		620	Sanitary Facility	Each						1	1	1	1	0	100%
3	48		626	Mobilization	L.S.	.05	.05	.05	.05	.05	.75	.75	1.0	1	0	100%
<u>STATE FURNISHED MATERIAL</u>																
2	7		504	Timber Cribbing	Sq. Ft.						3000	560	3000	560	2440	19%
<u>FORCE ACCOUNT</u>																
Cont. Billing			FA01	Minor Contract Revisions	F. A.						1	5,000.00	1	0.00	-5,000.00	0%
Cont. Billing			FA02	Erosion Control	F. A.						1	25,000.00	1	3,902.52	-21,097.48	15%
Cont. Billing			FA03	Landscaping Special Effects	F. A.						1	25,000.00	1	4299.41	-20,700.59	17%
Cont. Billing			FA04	Fencing (Deleted)	F. A.						1	3,000.00	1	0.00	-3,000.00	0%
Cont. Billing			C MC	Wage Rate Revisions							1	7,500.00	1	8,176.48	+676.48	108%

AS CONSTRUCTED
 REVISED DATE 6-13-78

FINAL
 SUMMARY OF APPROXIMATE QUANTITIES

cmo 1066 public service conduit

FEDERAL ROAD DISTRICT NO.	DIVISION	PROJ. NO.	SHEET NO.	TOTAL SHEETS
XXX	COLORADO	E70-2(40) RT	74x	31

INDEX			CONTRACT ITEM NO.	CONTRACT ITEM	UNIT	CHANGE	ORDERS	Estimated Amount	Estimated Cost	Final Totals	+ or -	%	PROJECT TOTALS	
BOOK	PAGE	SHEET												
DON Form	1007		203	Blading	Hour			0		125	+125	125	125 hrs @ \$42.00 5,250.00	
DON Form	1007		203	Dozing	Hour			0		171	+171	171	171 hrs @ \$74.00 12,554.00	
DON Form	1007		203	DOZING (Heavy)	Hour			0		100	+100	100	100 hrs @ \$81.00 8,100.00	
DON Form	1007		203	Truck (Dump)	Hour			700	17,500.00	602	-98	86	602 hrs @ \$25.00 15,050.00	
DON Form	1007		203	Front End Loader (Rubber Tired)	Hour			0		63	+63	63	63 hrs @ \$24.00 1,512.00	
DON Form	1007		203	Front End Loader	Hour			750	9,250.00	313	-437	125	313 hrs @ \$32.00 10,016.00	
DON Form	1007		203	Combination Loader	Hour			900	25,450.00	453	-447	73	453 hrs @ \$28.50 12,901.50	
								56,400.00			+274,801.50		TOTAL 74,896.50	
FORCE ACCOUNT														
Labor									22,981.00	12,213.80		53		12,767.20
Total Force Account (charge to I 70-2(38))									75,381					87,663.70

STRUCTURE QUANTITIES

AS CONSTRUCTED
 NO REVISION REVISED 6-15-78 VOID

FEDERAL ROAD REGION NO.	DIVISION	PROJECT NO.	SHEET NO.
VIII	COLORADO	170-2(68)197	4

INDEX	LOCATION	* UNCLASSIFIED EXCAVATION CUBIC YARD			STRUCTURE EXCAVATION CUBIC YARD	STRUCTURE BACKFILL CUBIC YARD CL. 2	Perforated Underdrain			CORRUGATED STEEL PIPE LINEAR FEET				"H" OVER CULV. FT.	STEEL END SECTION EACH		MISCELLANEOUS
		EXCAV.	EMB.	DITCH			1" Perforated Str. Exc. Lin. Feet	Exc. Culv. cu. yd.	24"	30"	42"	24"	42"				
1 7 1 8 1 18 1 19 1 7	204+25 213+00 215+00 225+00 235+00 0+94	23	5	27	911 2	68 5	36	0	0	20 18 22			5	1 2		1-Removal of Structure Deleted	
1 11 1 12 1 13	9+62 215+78 216+71 847+42(28) = 13+75 ± 219+76				12 2	64 5				22 18 20			4	1		Reset 24" End Section	
1 9 1 10 1 15 1 16	821+7 222+30 224+50 224+75 21+00 27+75 29+ 29+085 to 29+35.5	10			3	6	130 20	57 9	46 7	20 24			15	1			
		QUANTITIES IN SUMMARY															
1 19	29+60	10			3	6				20 22			2	1 2			
1 21	36+80 36+50	10		5	3	6				18 24			1	1			
1 23 1 23 1 24 1 27	42+58 42+50 46+00 48+00 51+00 57+085 to 49+35.5	10		5	12 12 3 2	78 6 6 6				18 22 24 20			15	0 0 0 0			
		QUANTITIES IN SUMMARY															
1 30 1 27	56+25 56+70 53+ UNDERPASS				2	5				22				1		Structure Deleted	
1 28	64+14 58+00	86	10		10 8	11				28 32			2	1 2			
1 31	68+39 68+50	15	5	12	113	810				20 24			2	1			
1 33	70+90 Deleted	10			8	8				20			15	1			
1 35	75+12	57	5	45	1213	89				22 24			2	1 2			
1 37	78+34 Deleted	10			8	6				28			6	1			
		Structure Deleted															
1 39 1 41	Deleted 80+70 84+ 87+70 90+ 88+77 Deleted	300			228	358				24			2	1			
1 43	94+80 96+50	10			112	110				18 20			1	1			
1 45	92+65	10			5	6				28 30			2	0			
		QUANTITIES IN SUMMARY															
1 47	94+25.5 to 25+19.5 97+70 97+10	10			23	9				18			1	1 0			
1 51	102+80 102+50	10			9	9				28			3	1 0			

384

STRUCTURE QUANTITIES

AS CONSTRUCTED
NO REVISION REVISED 4/13/85 VOID

FEDERAL ROAD REGION NO.	DIVISION	PROJECT NO.	SHEET NO.
VIII	COLORADO	I 70-2(68) 197	5

INDEX	LOCATION	* UNCLASSIFIED EXCAVATION CUBIC YARD			STRUCTURE EXCAVATION	STRUCTURE BACKFILL	Particulate Under Drains			CORRUGATED STEEL PIPE					*H" OVER CULV. FT.	STEEL END SECTION		MISCELLANEOUS	
		EXCAV.	EMB.	DITCH	CUBIC YARD	CUBIC YARD CL. 2	6" picketed Str. Ex. Lin. Ft.	Filt. Mat. Cu. Yd.	On Vol.	LINEAR FEET					FT.	EACH			
										24"				42"		24"	42"		
1 53	109+00	10		5	5									18			1.5	2	
	116+92.5 to 117+50.5			QUANTITIES IN SUMMARY															
1 58	119+00 to 120+20	10		5	6									16			1	2	
1 59	124+91 to 124+150	10		5	6									20			1.5	2	
	126+52.5 to 127+02.5			QUANTITIES IN SUMMARY															
1 63	129+25 Deleted	10		5	5									18			1	2	
1 66	130+30 to 131+50						100	44	35										
1 65	131+64 to 131+170				5	10								32			3	2	
1 67	132+34 to 132+150	10			6	9								20			1.5	2	
1 69	137+90 to 138+90	10			12	11								22			4	2	
	139+ to 141+	200																	
1 71	144+90	10			8	14									26		1.5		1
1 73	146+70 to 147+20	10			14	13								30			4.5	2	
2 7	148+ to 148+150				39	125													560 800 Sp. Ft. - Place Timber Cribbing
2 9	152+40 Deleted	10			5	4								30			5	2	
2 8	153+41 to 155+99						220	96	78										
2 11	154+80 to 154+150	10			5	9/10								22 24			2	2	
2 12	158+48 to 162+52						440	193	156										
2 13	159+70	10			5	8/7								22			2.5	2	
2 14	163+20 to 164+75				58	134	214	116	93					30				2	
2 15	166+ to 166+150 DELETED																		800 Sp. Ft. - Place Timber Cribbing
2 17	166+55 to 168+50	10			43	69								20 30			1.5	2	
2 20	169+13 to 173+55						620	271	219										
2 19	170+00	10			12	16									28		4		2
2 21	172+70 to 173+28	10			23	186								28 24			2.5	2	
2 23	175+59 Deleted	10			43	76								24 24			1.5	1	
2 22	176+150																		
2 25	182+60 to 184+00	10			15	7								24			2	2	
2 26	184+00 to 185+20				17														
2 27	188+20 to 187+90	10			18	47	120	52	42					18 24			1.5	2	
2 29	193+05 Deleted	10			5	6								18			1	2	
2 30	193+05 Deleted 21.2 miles. Head of Copper Mt. boundary						50	22	18										
	TOTALS	971	25	114	608	963	2200	948	765					54					3
	Particulate Under Drains				399	421													
	TOTAL				1250	422													

* For information only, to be paid for under Equipment Hours

FEDERAL ROAD DISTRICT NO.	DIVISION	PROJ. NO.	SHEET NO.	TOTAL SHEETS
III	COLORADO	170-2(68)197	6	31

AS CONSTRUCTED			
NO REVISIONS	6-3-78	REVISED	VOID

TYPICAL CHANNEL CHANGE DETAIL

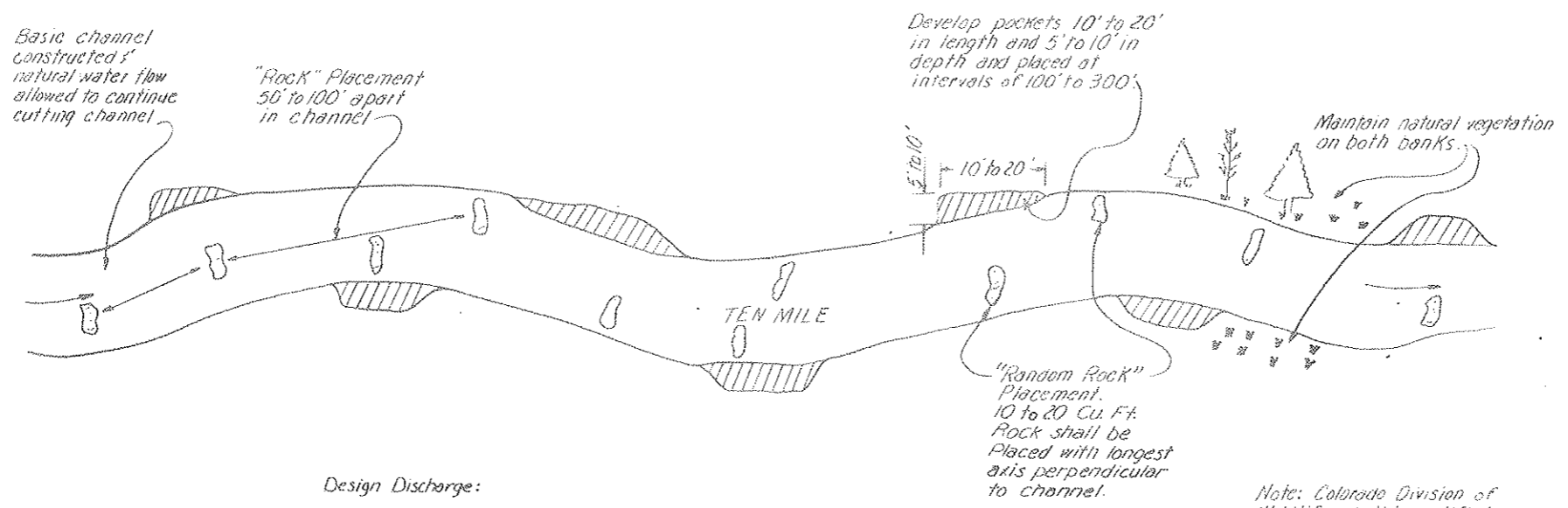

Note: Work on this sheet shall be done under appropriate equipment hours.

Note: Colorado Division of Wildlife shall be notified before any channel changes are made.

FEDERAL ROAD DISTRICT NO.	DIVISION	PROJ. NO.	SHEET NO.	TOTAL SHEETS
VIII	COLORADO	I 70-2(68)197	7	31

AS CONSTRUCTED			
NO REVISIONS	1-13-43	REVISED	VOID

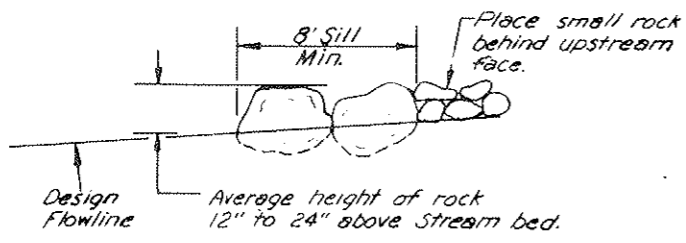
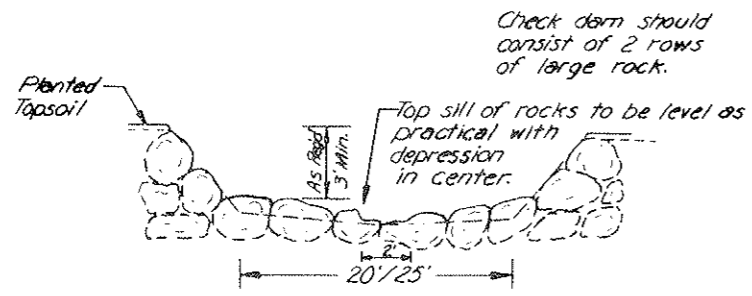
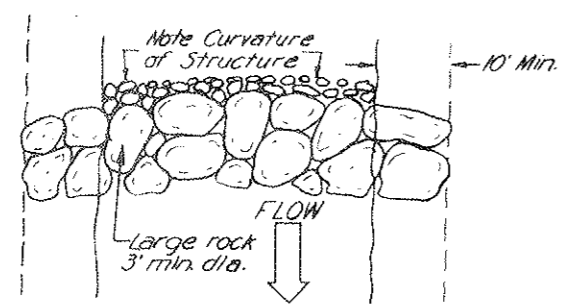

ROCK DAM

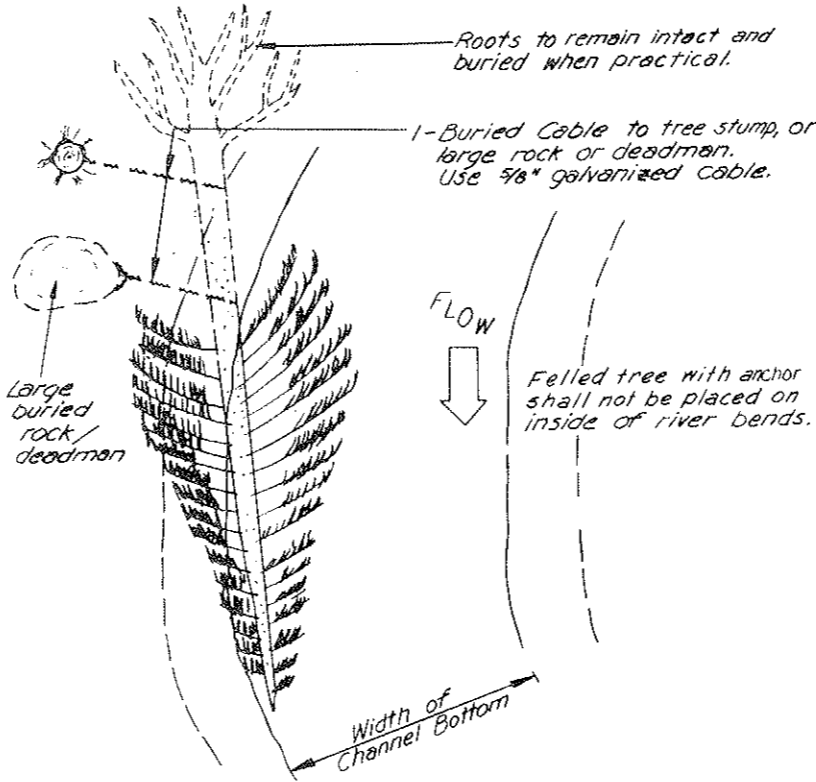

FELLED TREE WITH ANCHOR

NOTE: Work on this Sheet will be paid for under Force Account-Landscaping Special Effects.

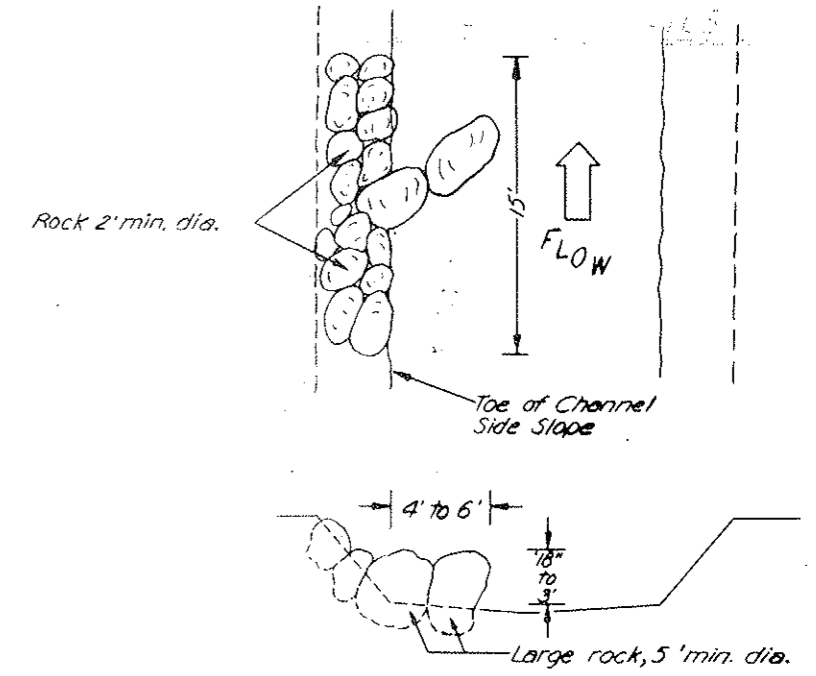

ROCK DEFLECTOR

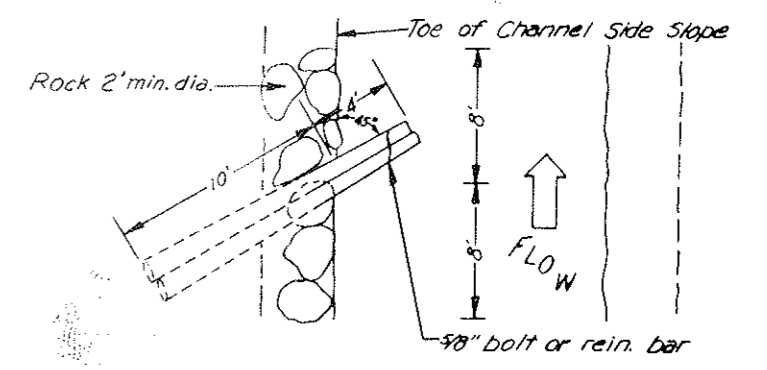

LOG DEFLECTOR

Note - Log diameter 12" Minimum



AS CONSTRUCTED			FEDERAL ROAD REGION NO.	DIVISION	PROJ. NO.	SHEET NO.	TOTAL SHEETS
NO REVISIONS	REVISED	VOID	VIII	COLORADO	I 70-2(68)197	8	31

TIMBER CRIB WALL DETAILS

- NOTES
1. ALL WORK SHALL BE DONE IN ACCORDANCE WITH THE STANDARD SPECIFICATIONS.
 2. ALL CRIBS TILT BACK TO FILL @ 2":12"
 3. STABILITY COMPUTATIONS BASED ON 1-1/2:1 BACKSLOPE.
 4. ALL TIMBER AND DRIFT PINS WILL BE STATE FURNISHED. TIMBER SHALL BE CUT AND REDRILLED TO FIT.
 5. DRIFT PINS & HOLES TO BE 3/4" Ø.
 6. ALL STRETCHERS TO BE LAYED HORIZONTAL.
 7. FILL WITHIN CRIBS & BEHIND CRIBS CONSISTS OF SAND, SAND & GRAVEL, OR OTHER FREE DRAINING GRANULAR MATERIAL PLACED IN 6" LAYERS AND COMPACTED WITH VIBRATORY COMPACTORS.
 8. SOIL WEIGHT ASSUMED TO BE 125#/FT³.
 9. EQUIVALENT SOIL FLUID PRESSURE 30#/FT³.
 10. WELDED WIRE FABRIC SHALL HAVE A MAXIMUM GRID OPENING OF 2" X 1" AND SHALL BE FABRICATED WITH 14 GAGE GALVANIZED WIRE. WIRE FABRIC SHALL BE FURNISHED BY CONTRACTOR. PAYMENT WILL BE INCLUDED IN "PLACE TIMBER CRIBBING."
 11. THE WELDED WIRE FABRIC SHALL BE FASTENED TO THE TIMBER STRETCHERS BY STAPLING IN HORIZONTAL ROWS WITH A MINIMUM OF FIVE STAPLES PER ROW. STAPLES WILL BE 2" CEMENT COATED, BARBED. THE WELDED WIRE FABRIC SHALL BE STAPLED AT THE TOP AND BOTTOM STRETCHERS AND AT ALTERNATE INTERMEDIATE STRETCHERS. IF THE WIRE IS TO BE OVERLAPPED, THE MINIMUM OVERLAP SHALL BE FOUR INCHES.



ROCK WALL DETAILS

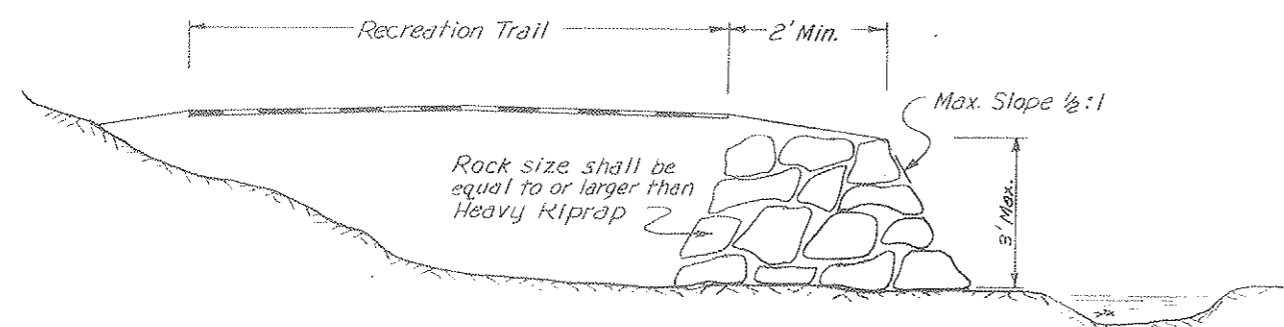

NOTE: Rock wall construction will be paid for under appropriate equipment hours where directed.

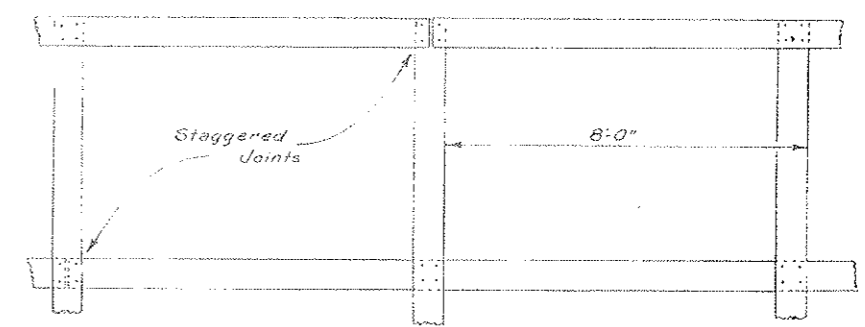

TYPICAL PLAN VIEW

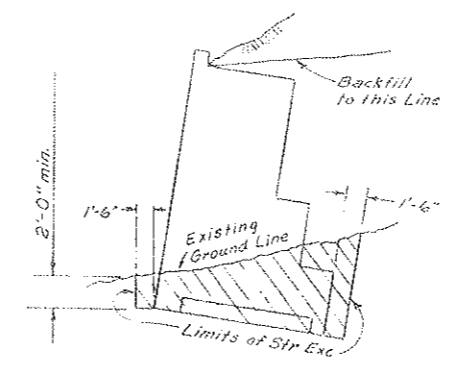

STR. EXC. & BACKFILL DETAIL

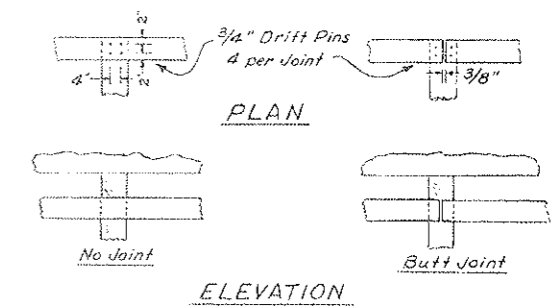

PLAN

ELEVATION

GENERAL NOTES

ALL WORK SHALL BE DONE ACCORDING TO THE STANDARD SPECIFICATIONS OF THE DIVISION OF HIGHWAYS, STATE OF COLORADO, APPLICABLE TO THE PROJECT.

PRESERVATIVE TREATMENT SHALL BE IN ACCORDANCE WITH THE AMERICAN WOOD PRESERVERS ASSOCIATION SPECIFICATION C28 FOR GLUE LAMINATED MEMBERS AND SPECIFICATION C2 FOR LUMBER.

PRESERVATIVE TREATMENT SHALL BE WATERBORNE SALTS, PENTACHLOROPHENOL IN VOLATILE HYDROCARBON SOLVENTS OR PENTACHLOROPHENOL IN LIGHT OIL. BACKING PLANKS, BULL RAIL AND DECK PLANKS SHALL BE TREATED FOR GROUND CONTACT USE. HANDRAILS AND POSTS SHALL NOT BE TREATED WITH PENTACHLOROPHENOL IN LIGHT OIL.

EXCAVATION FOR FOOTINGS SHALL BE TO SOUND MATERIAL IN ORIGINAL GROUND. IF SOUND MATERIAL IS NOT FOUND, THE BRIDGE ENGINEER WILL INSPECT AND DETERMINE IF REDESIGN IS NECESSARY.

WHEN EXCAVATING FOR FOOTINGS, THE FINAL SIX INCHES IN DEPTH SHALL BE DONE BY HAND LABOR METHODS.

PORTIONS OF FOOTINGS BELOW THE ORIGINAL GROUND LINE NEED NOT BE FORMED BUT ANY EXTRA MATERIALS REQUIRED FOR THIS WILL NOT BE PAID FOR.

FOR DETAILS OF STRUCTURE EXCAVATION AND BACKFILL, SEE STANDARD M 206-AB.

ALL STRUCTURAL STEEL NOT OTHERWISE NOTED SHALL BE A.A.S.H.T.O. SPECIFICATION M-103 (ASTM A-16).

THE WORK AND MATERIALS SHALL ALSO CONFORM TO APPLICABLE AISC SPECIFICATIONS.

THE GIRDERS NEED NOT BE CAMBERED.

THE TOP OF DECK PLANKS AND THE BACK OF BACKING PLANKS NEED NOT BE RESURFACED AFTER LAMINATING, AND MAY BE LAMINATED FROM 5/2S LUMBER.

ALL TIMBER SHALL BE DOUGLAS FIR, OR ALL TIMBER SHALL BE SOUTHERN PINE.

EXCEPT AS NOTED, ALL LAMINATED TIMBER SHALL BE OF THE INDUSTRIAL APPEARANCE GRADE.

ALL ADHESIVES USED SHALL BE SUITABLE FOR CONTINUOUS WET USE.

HARDWOOD SHIMS SHALL BE ONE OF THE FOLLOWING: TRUE HICKORY, PECAN, AMERICAN BEECH, SWEET BIRCH, YELLOW BIRCH, BRICK ELM, BLACK MAPLE, SUGAR MAPLE (HARD MAPLE), COMMERCIAL WHITE ASH, COMMERCIAL RED OAK, COMMERCIAL WHITE OAK. HARDWOOD SHIMS SHALL BE ORIENTED TO MATCH THE GRADE TO THE EXTENT PRACTICAL AND SHALL BE GLUED TO THE GIRDER IN THE FIELD. THEY SHALL RECEIVE THE SAME PRESERVATIVE TREATMENT AS THE SOFTWOOD, BUT NO PARTICULAR RETENTION WILL BE REQUIRED.

ALL HARDWARE SHALL BE GALVANIZED EXCEPT C.I.O.G. WASHERS.

HEADS OF BOLTS AND NUTS SHALL HAVE C.I.O.G. WASHERS WHERE THEY WOULD OTHERWISE BEAR ON WOOD, EXCEPT THAT 3/8" HANDRAIL BOLTS MAY HAVE OVERSIZE HEADS.

TIMBER QUANTITIES ARE BASED ON NOMINAL SIZES FOR LUMBER; FOR LAMINATED MEMBERS ON NET FINISHED SIZES.

TRUCKS UP TO THE STATE LEGAL LOAD LIMITS WILL BE PERMITTED DURING CONSTRUCTION AND PAVING WITH THE FOLLOWING RESTRICTIONS: TIRE PRESSURES SHALL NOT EXCEED 50 PSI; THE TRAVELLED WAY SHALL BE RESTRICTED TO 10 FT. WIDTH BY TEMPORARILY MOUNTING THE BULL RAILS 10 FT. APART. THE DECK SHALL NOT BE PAVED AT THE TIME THE LOAD CROSSES THE BRIDGE.

TIMBER BOLTS AND LAG BOLTS SHALL BE RETORQUED AFTER THE LAST OVERLOAD HAS PASSED.

THE STRUCTURE NUMBER SHALL BE BRANDED ON THE LEFT HAND RAILING POST ON EACH END OF THE BRIDGE AND THE STREAM NAME ON THE RIGHT HAND RAILING POST, BOTH IN 3-INCH BLOCK LETTERS.

REINFORCING STEEL SHALL BE GRADE 60.

LOADING DATA:
LIVELOAD: 8 TON TYPE 3 (3-AXLE) STATE TRUCK, OR PEDESTRIANS EQUAL 60 PSF
DEADLOAD: ASSUMES 25 LBS. PER SQ. FT. FOR BITUMINOUS PAVEMENT

DESIGN DATA:
A.A.S.H.T.O. 1973 UNIT STRESSES EXCEPT AS NOTED.
REINFORCED CONCRETE: REINFORCING, $f_s = 24,000$ PSI
CONCRETE, $f_c = 1,200$ PSI
 $n = 10$

TIMBER: DRY UNIT STRESSES APPROPRIATE TO GRADE SPECIFIED EXCEPT WET STRESSES FOR DECK PLANKS.

TEMPORARY STRESSES = 150% OF DRY UNIT STRESSES FOR ALL TIMBER.

AS CONSTRUCTED
NO REVISIONS REVISED 2-23-83 VOID

FEDERAL ROAD REGION NO.	DISTRICT	PROJ. NO.	SHEET NO.	TOTAL SHEETS
VII	COLORADO	170-2 (68)197	9	31

REVISIONS			
5-9-77	ADDED NOTE		MLM

SUMMARY OF QUANTITIES

ITEM NO.	DESCRIPTION	UNIT	F-12-AZ	F-12-BA	F-12-BB	F-12-BC	F-12-BD	TOTAL
206	STRUCTURE EXCAVATION	CU YD	55	40	50	50	50	245
206	STRUCTURE BACKFILL (CLASS 2)	CU YD	20	10	15	10	10	65
④ 403	HOT BITUMINOUS PAVEMENT (GRADING E) (HAUL & ASPHALT)	TON	4	4	5	8	6	27
④ 411	ASPHALT CEMENT	TON						
① 506	RIPRAP	CU YD	30	30	30	30	30	150
④ 508	TREATED TIMBER	MFSM	2.66	2.66	4.05	6.81	4.90	21.08
601	CONCRETE CLASS A (BRIDGE)	CU YD	6	4	5	3	4	22
602	REINFORCING STEEL	LB.	440	270	350	270	290	1,620
626	MOBILIZATION	L.S.	.05	.05	.05	.05	.05	.25

- ① 9" STONE SIZE, APPROXIMATE QUANTITIES ONLY
- ② Future Construction
- ④ ALL MEMBERS SHALL BE FABRICATED BEFORE TREATMENT.

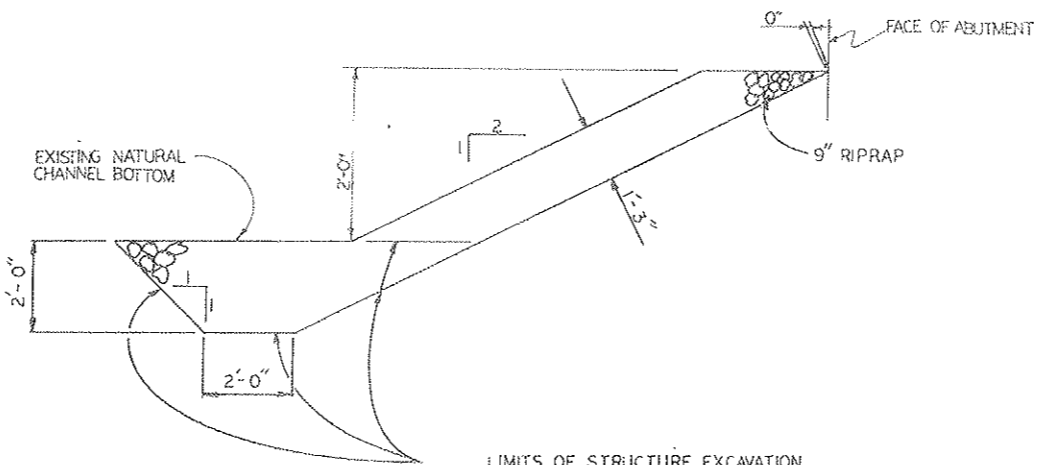

RIPRAP DETAILS
RIPRAP IS A THEORETICAL DESIGN AND MAY BE ADJUSTED BY THE ENGINEER TO FIT FIELD SITE CONDITIONS.

INDEX OF DRAWINGS

- DWG. NO. B 1 GENERAL INFORMATION - SUMMARY OF QUANTITIES
- DWG. NO. B 2 GENERAL LAYOUT - F-12-AZ
- DWG. NO. B 3 GENERAL LAYOUT - F-12-BA
- DWG. NO. B 4 GENERAL LAYOUT - F-12-BB
- DWG. NO. B 5 GENERAL LAYOUT - F-12-BC
- DWG. NO. B 6 GENERAL LAYOUT - F-12-BD
- DWG. NO. B 7 BRIDGE DETAILS

BRIDGE DESCRIPTION

1-SPAN (25'-0" AZ; (25'-0" BA; (37'-0" BB; (55'-0" BC; (43'-0" BD);
LAMINATED TREATED TIMBER BRIDGES
OVER WEST TERRILE, CORRAL, OR STAFFORD CREEK

12'-0" ROADWAY, CURB TO CURB. 90° SKEW

5" BULL RAILS, TIMBER PEDESTRIAN RAILING

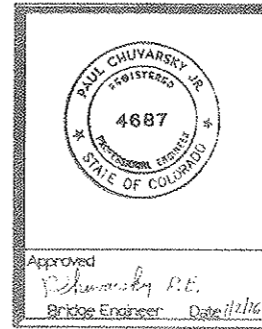

DIVISION OF HIGHWAYS

GENERAL INFORMATION
SUMMARY OF QUANTITIES

Station 29+22.0 TO
Station 126+80.0

Near WHEELER JCT Sec 20 T 6S R 79W

Designer M McMullen Structure F-12-AZ, BA, BB, BC,
Detailer K Heater Numbers BD
Drawing Number B 1 of 7 Drawings

DESIGNED BY	DATE	CHECKED BY	DATE
M.M.	5-76	J.L.R.	8-76
QUANTITIES BY	DATE	QUANTITIES BY	DATE
K.D.H.	5-76	M.L.M.	5-76
DETAILS BY	DATE	DETAILS BY	DATE
K.D.H.	5-76	K.D.H.	5-76

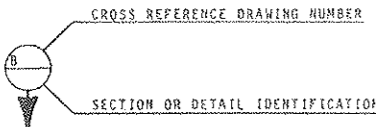

AS CONSTRUCTED
 NO REVISIONS 6-13-78 REVISED VOICE

FEDERAL ROAD REGION NO.	DIVISION	PROJ. NO.	SHEET NO.	TOTAL SHEETS
VIII	COLORADO	I 70-2 (68)197	10	31

REVISIONS	

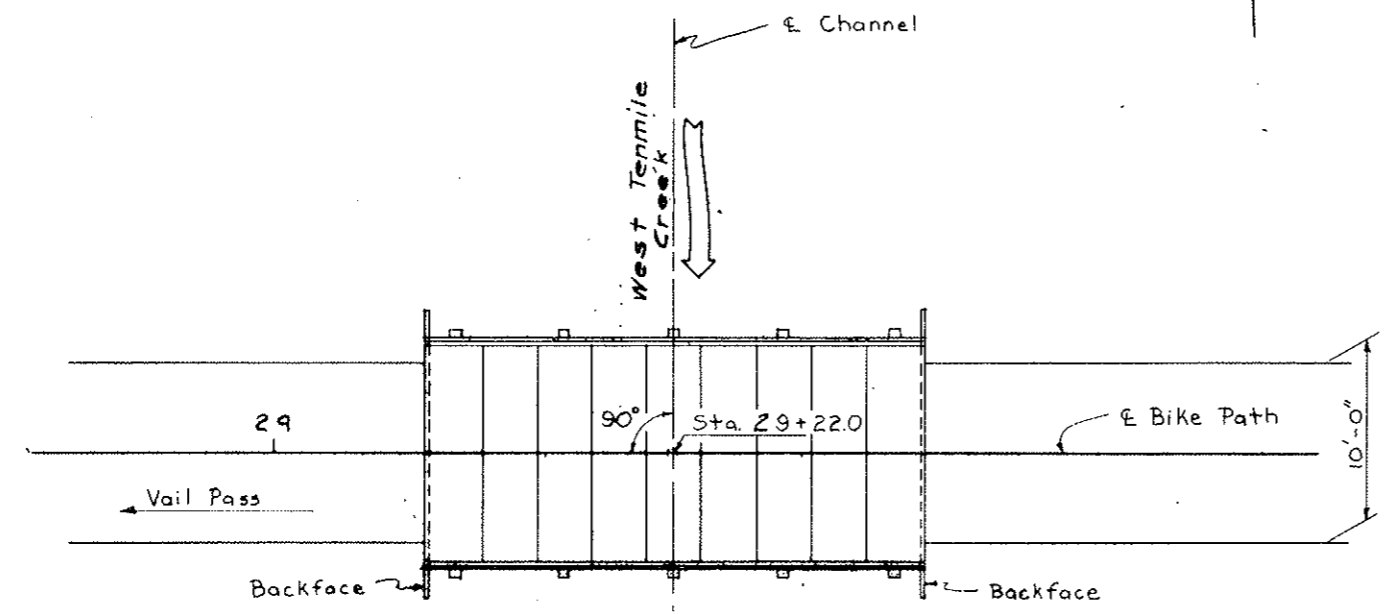

PLAN

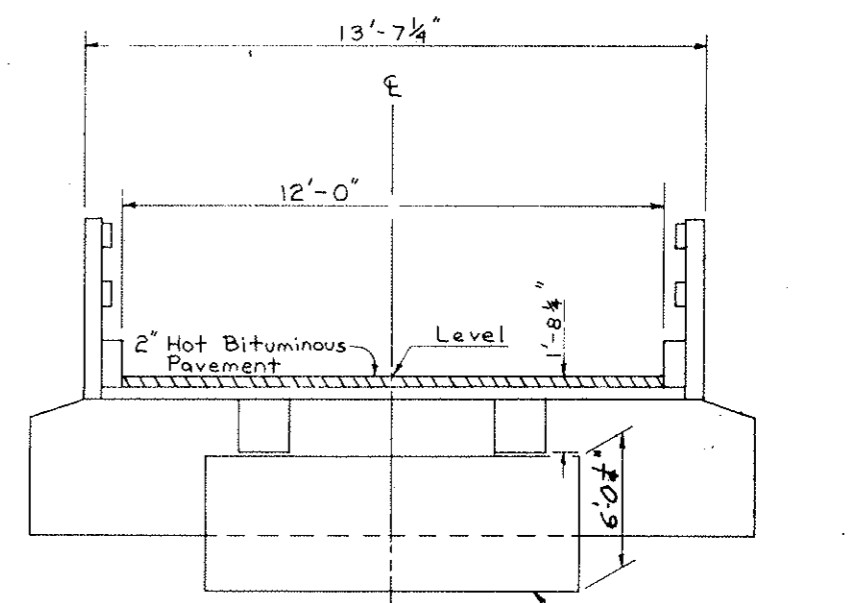

TYPICAL SECTION

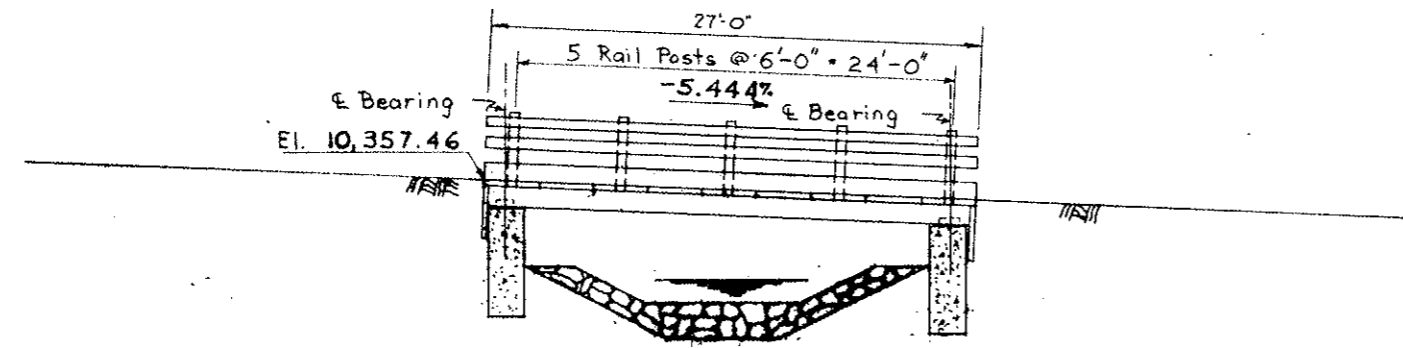

ELEVATION
 (Taken @ E Bike Path)

D.A. = 3.12 Sq. Mi.
 Q₁₀₀ = 110 c.f.s.
 HW = 10,351.0
 Q₁₀ = 85 c.f.s.

DESIGNED BY	CHK'D BY	DATE
DRAWN BY	APP'D BY	
CHECKED BY	DATE	
QUANTITIES BY	DATE	
DETAILS BY	DATE	

DIVISION OF HIGHWAYS

GENERAL LAYOUT

Designer M. L. McMullen	Structures	F-12-AZ
Detailer W. R. Hessler	Numbers	
Drawing Number B 2	of 7	Drawings

Revision Data (Preliminary Stage Only)

AS CONSTRUCTED		
NO REVISIONS	REVISED	VOID
0	1	0

FEDERAL ROAD REGION NO.	DIVISION	PROJ. NO.	SHEET NO.	TOTAL SHEETS
XIII	COLORADO	170-2 (68)197	11	31

REVISIONS			

DESIGNED BY	DATE	CHECKED BY	DATE
M.L.M.	4-78	M.L.M.	6-78
DESIGNED BY	DATE	CHECKED BY	DATE
M.L.M.	4-78	M.L.M.	6-78
DESIGNED BY	DATE	CHECKED BY	DATE
M.L.M.	4-78	M.L.M.	6-78

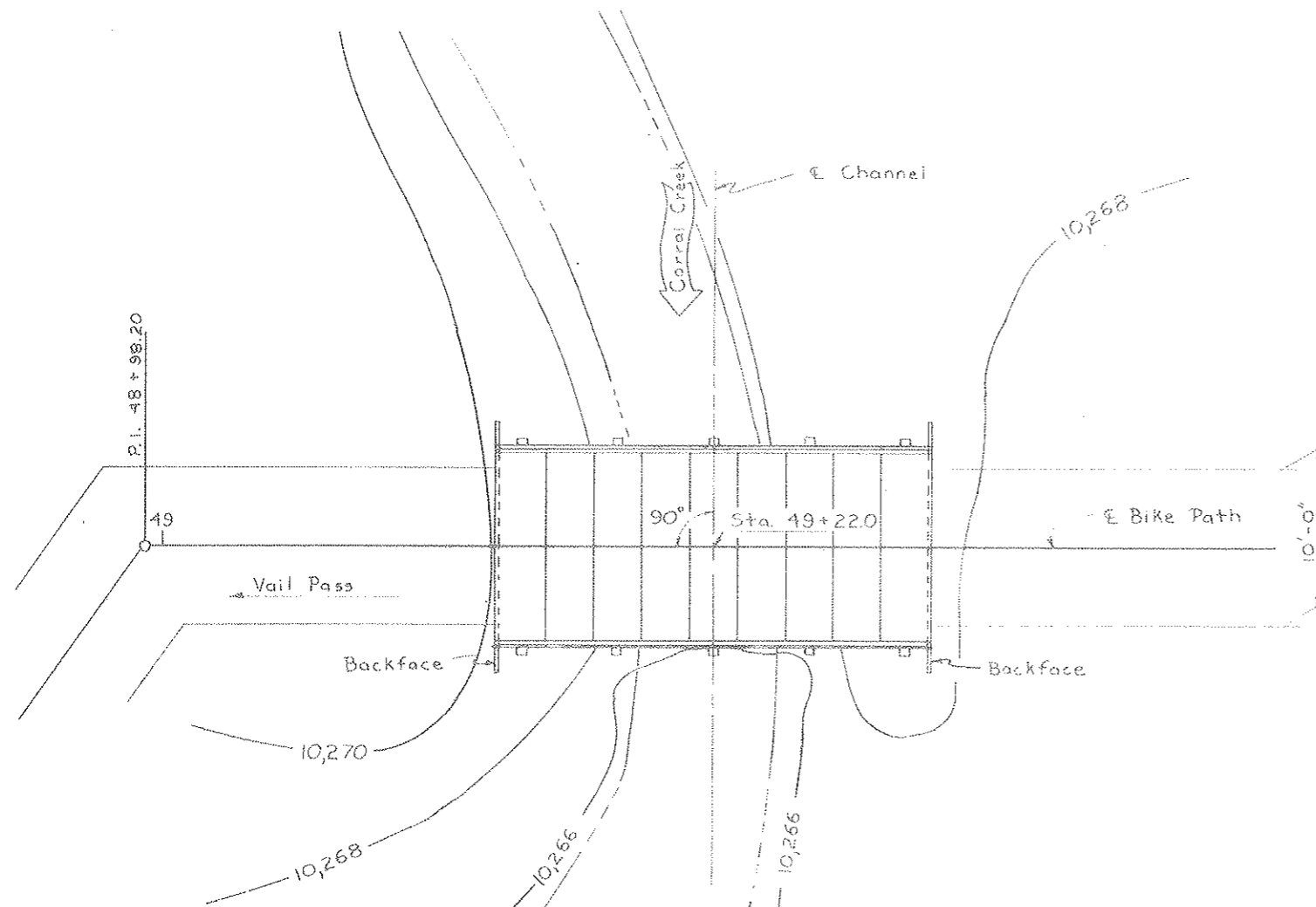

PLAN

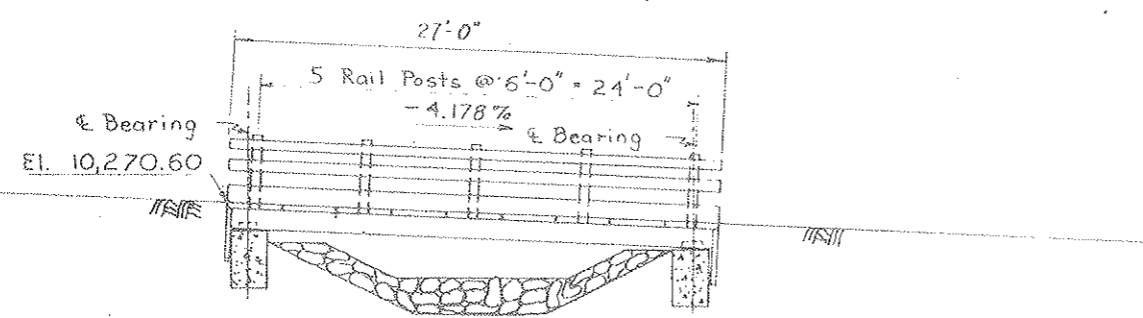

ELEVATION
(Taken @ E Bike Path)

DA: 2.35 Sg M
Q₁₀₀: 99 cfs
HW: 10,267.5
Q₅₀: 70 cfs
AHW: 10,268.5
DHW: 10,267.3

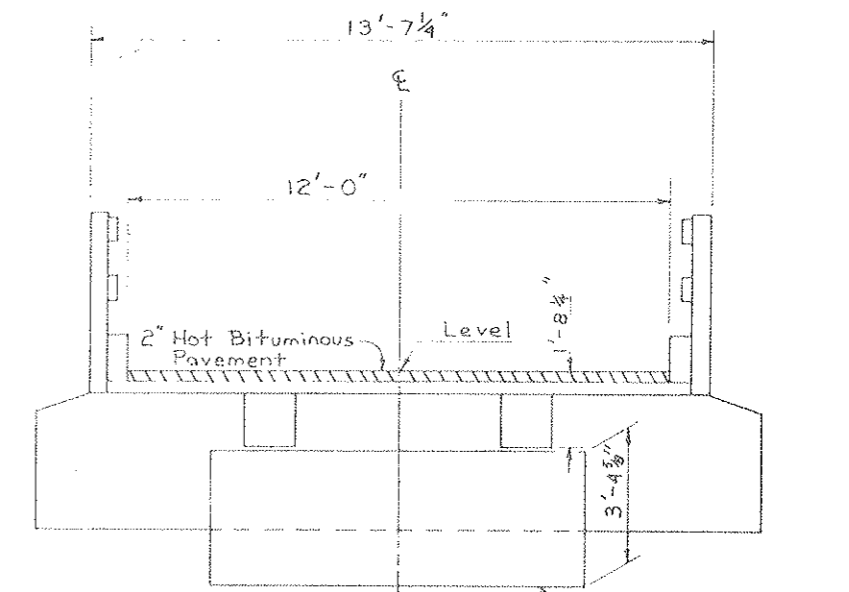
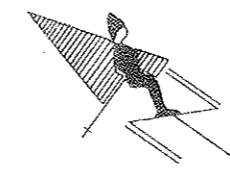

TYPICAL SECTION

Elev. 10265.4 Abut. 1
Elev. 10264.3 Abut. 2

DIVISION OF HIGHWAYS			
GENERAL LAYOUT			
Designer	M.L. McMullen	Structure	F-12-BA
Detailer	W.R. Hessler	Numbers	
Drawing Number	B 3	of	7 Drawings

Revision Dates (Preliminary Stage Only)

AS CONSTRUCTED			
NO REVISIONS	REVISED	VOID	

FEDERAL ROAD DISTRICT NO.	DIVISION	PROJ. NO.	SHEET NO.	TOTAL SHEETS
333	COLORADO	I 70-2 (68) 197	12	31

REVISIONS		

CHECKED BY	DATE	DESIGNED BY	DATE
CHECKED BY	DATE	DESIGNED BY	DATE

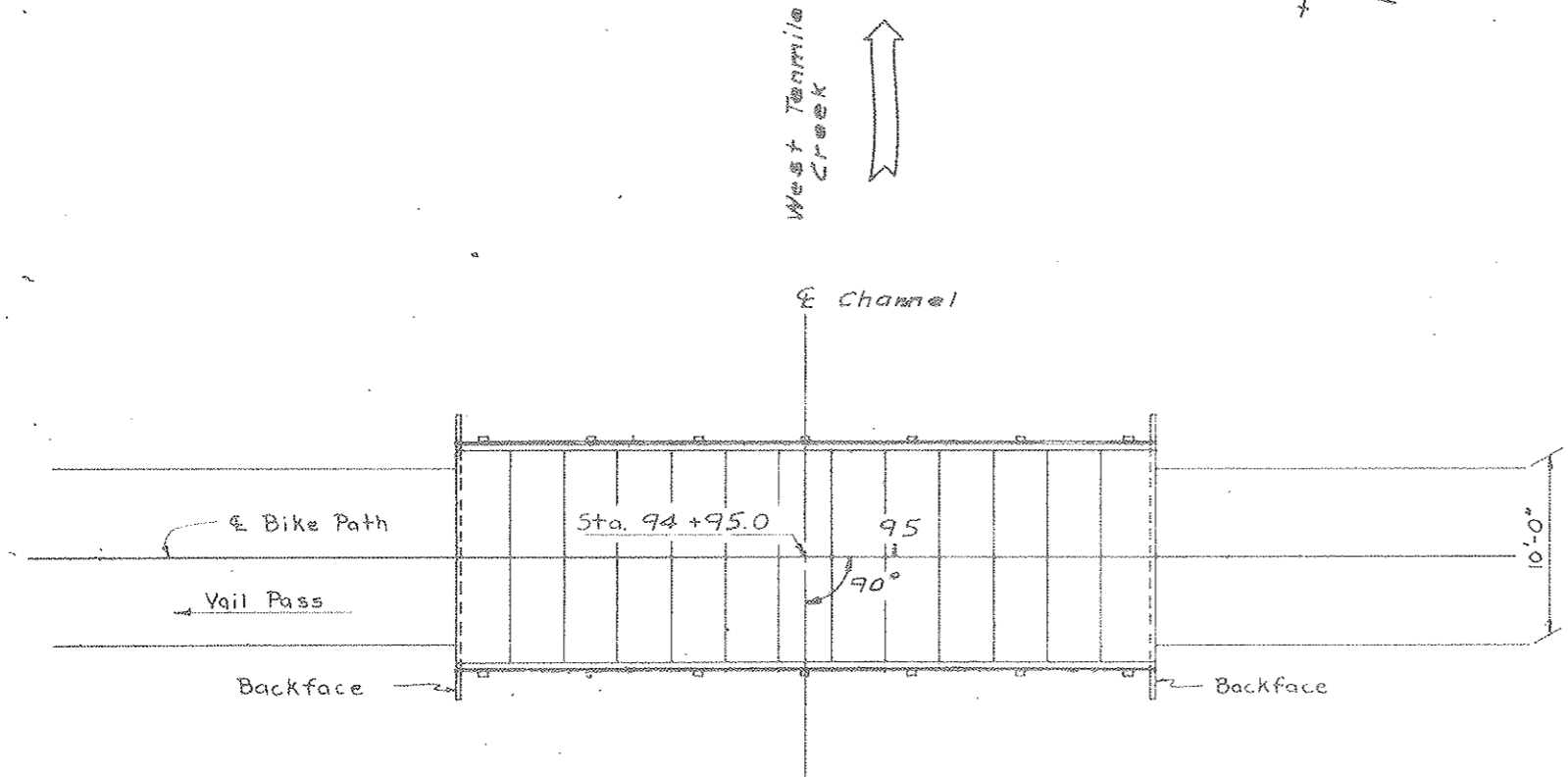

PLAN

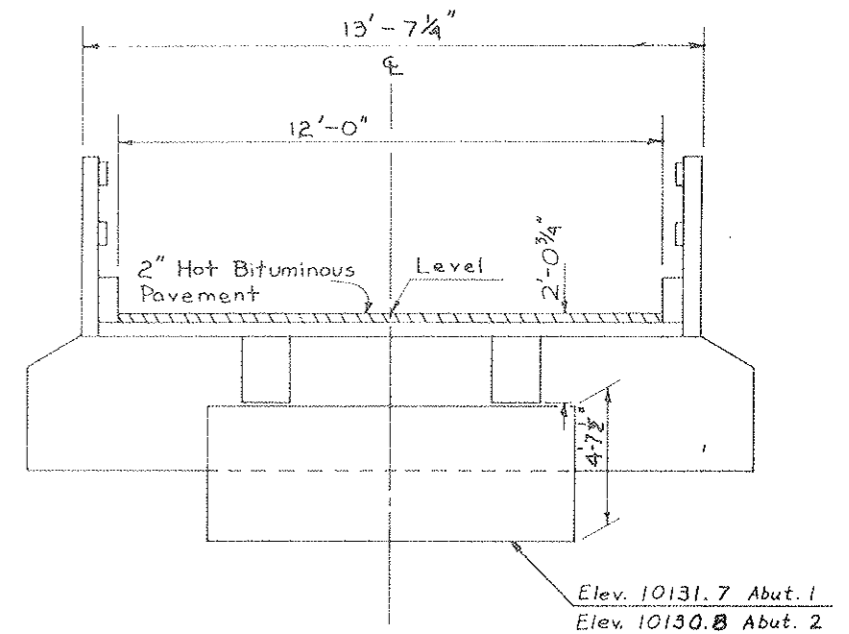

TYPICAL SECTION

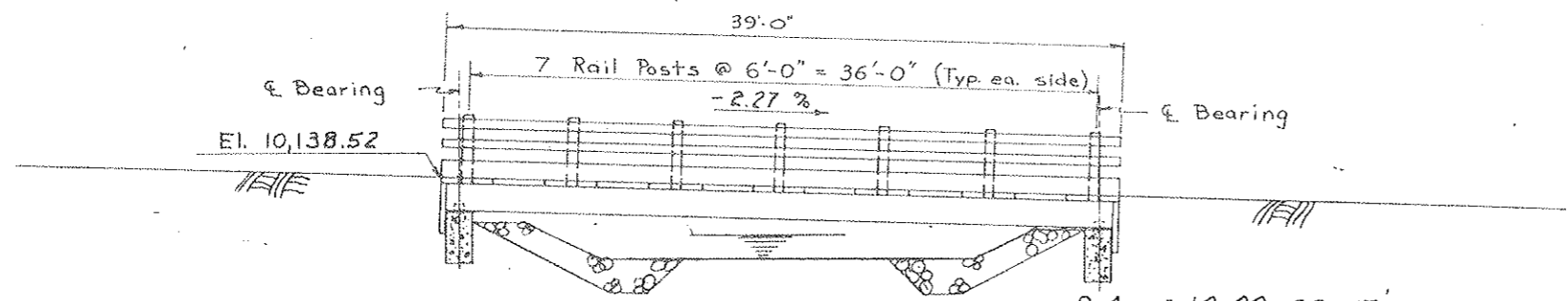

ELEVATION
 (Taken @ E Bike Path).

D.A. = 10.00 sq. mi.
 Q100 = 300 cfs
 H.W. = 10,135.2
 Q10 = 215 cfs

DIVISION OF HIGHWAYS			
GENERAL LAYOUT			
Designer	M.L. McMullen	Structure Numbers	F-12-BB
Designer	W.R. Hessler	Numbers	
Drawing Number	B	of	7 Drawings

Revision Dates (Preliminary Stage Only)

AS CONSTRUCTED		
NO REVISIONS	6-13-78	REVISED
		VOID

FEDERAL ROAD REGION NO.	DIVISION	PROJ. NO.	SHEET NO.	TOTAL SHEETS
VIII	COLORADO	I 70-2168)197	13	31
REVISIONS				

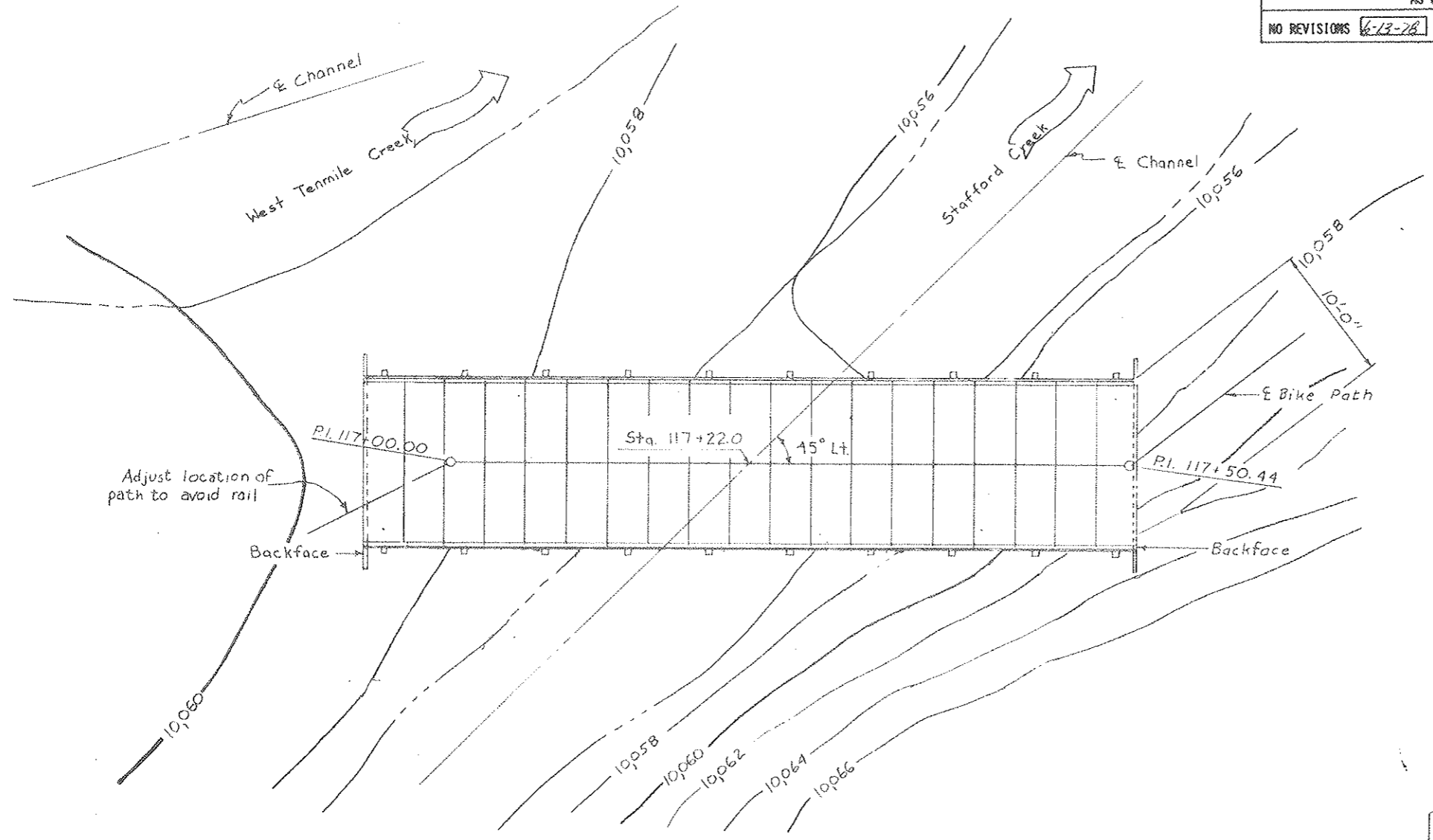

PLAN

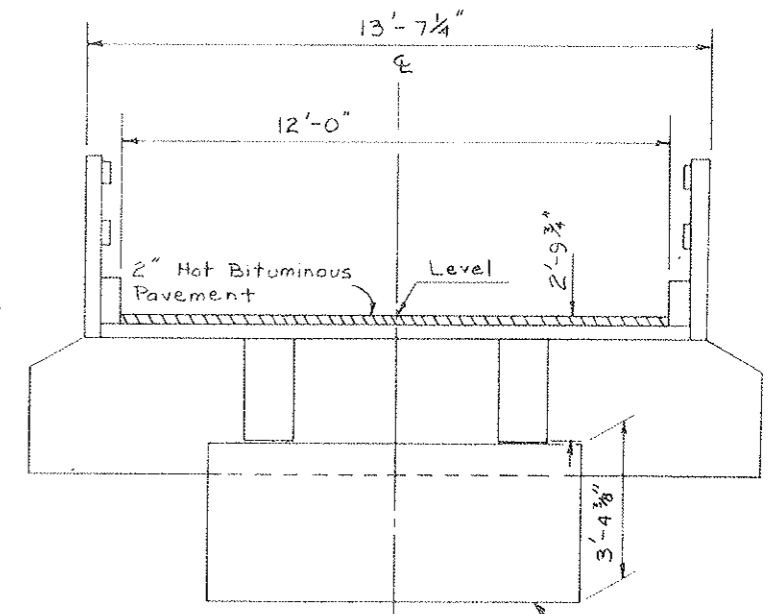
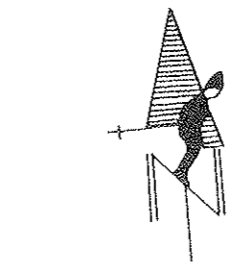

TYPICAL SECTION

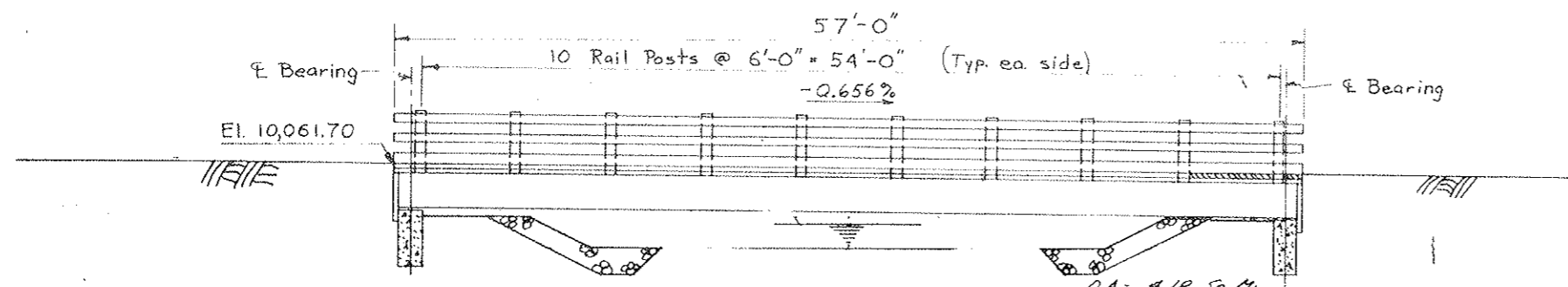

ELEVATION
(Taken @ E Bike Path)

DA = 4.18 59 ft.
D100 = 150 cfs
HW = 10,057.9
D10 = 105 cfs
AHW = 10,058.9
DHW = 10,057.7

DESIGNED BY	DATE	CHECKED BY	DATE
W.R.H.	4-7-78	M.L.M.	6-7-78
CHECKED BY	DATE	QUANTITIES BY	DATE
W.R.H.	4-7-78	K.D.H.	6-7-78

DIVISION OF HIGHWAYS			
GENERAL LAYOUT			
Designer	M.L. McMullen	Structure	F-12-BC
Detailer	W.R. Hessler	Numbers	
Drawing Number	B 5	of	7 Drawings

Revision	Date	Description
		(Preliminary Stage Only)

AS CONSTRUCTED
NO REVISIONS REVISED VOID

FEDERAL ROAD REGION NO.	DIVISION	PROJ. NO.	SHEET NO.	TOTAL SHEETS
VIII	COLORADO	I 70-2 (60)197	14	31

REVISIONS	

DESIGNED BY	CHECKED BY	DATE	INITIAL
YLB	YLB	4-76	YLB
MLM	MLM	6-76	MLM
NRH	NRH	4-76	NRH

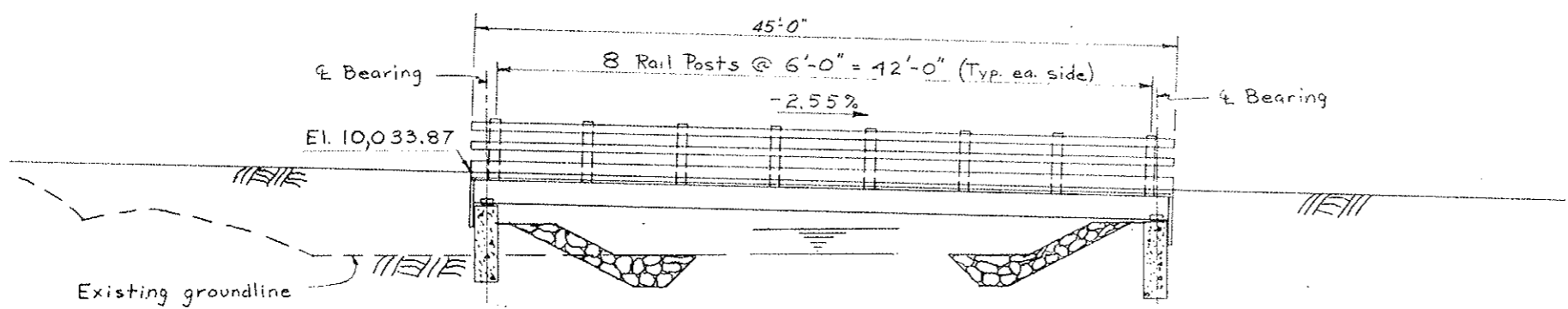
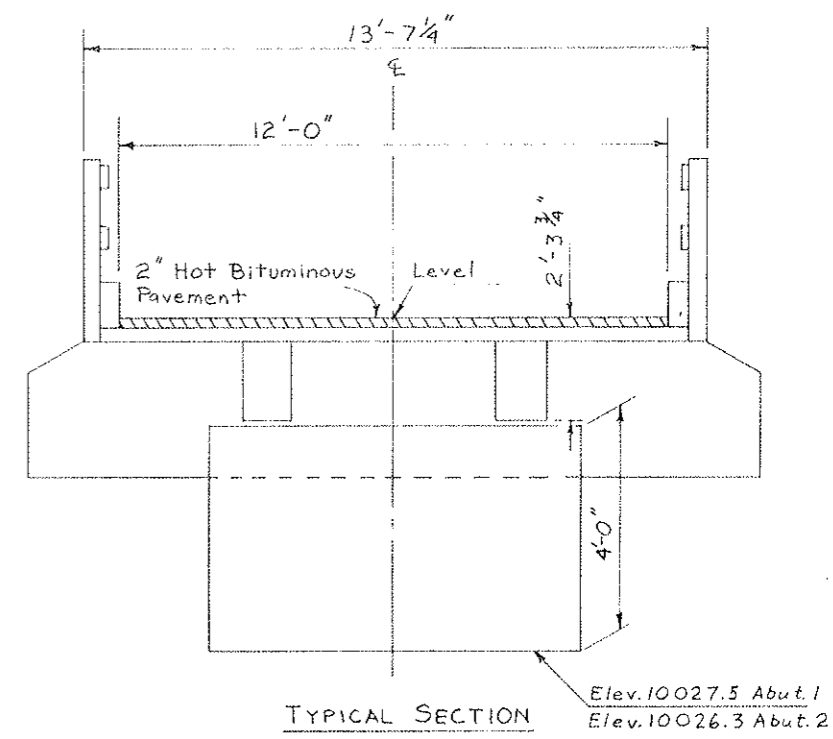
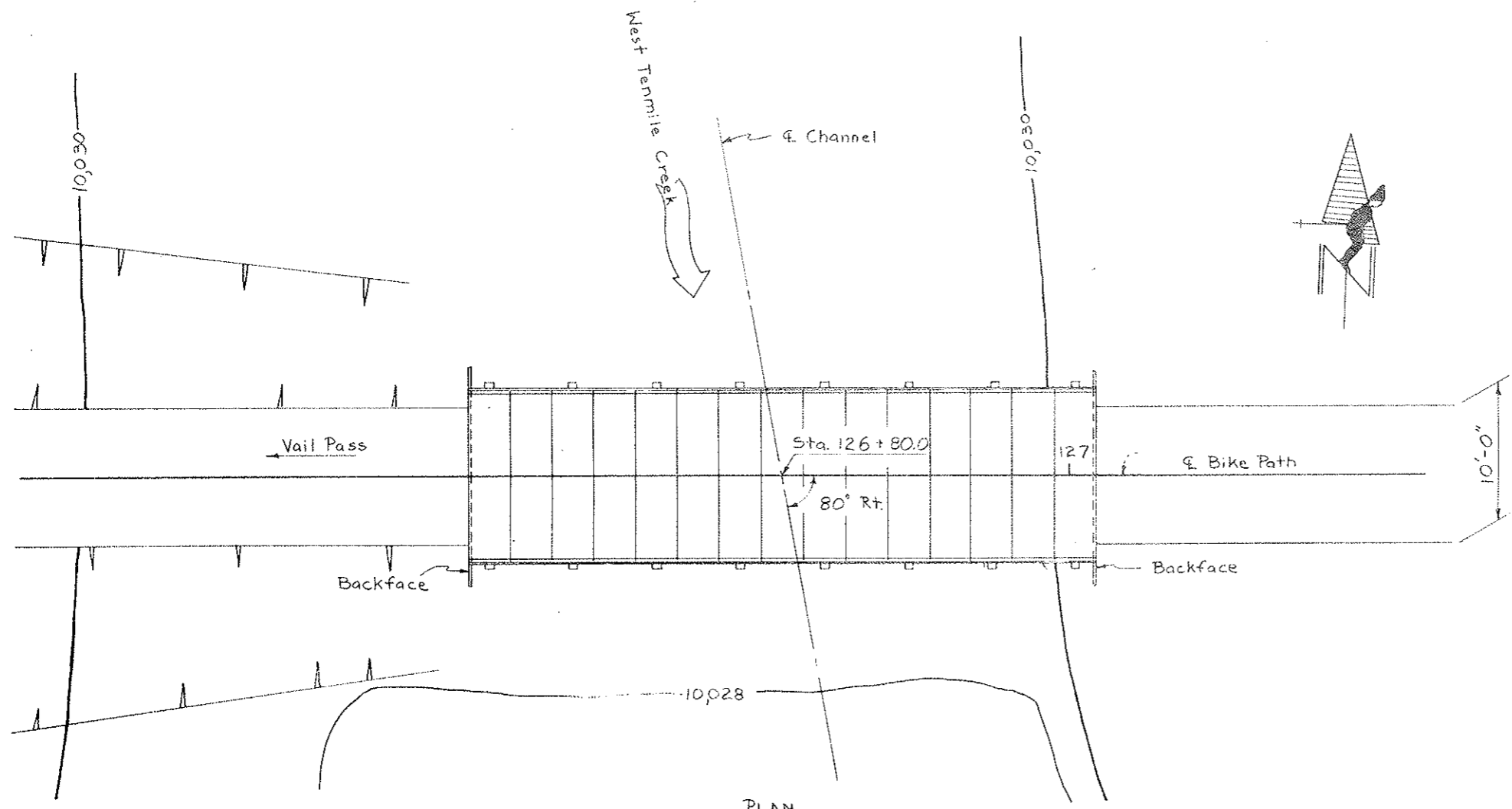

ELEVATION
(Taken @ E Bike Path)

DA: 14.58 sq. ft.
Q100: 395 cf.
H.W.: 10,030.2
Q10: 285 cf.
A.H.W.: 10,031.2
D.H.W.: 10,029.9

DIVISION OF HIGHWAYS

GENERAL LAYOUT

Designer M.L. McMullen	Structure Numbers	F-12-B.D
Detailer W.R. Hessler		
Drawing Number B 6	of 7	Drawings

Revision Dates: _____ (Preliminary Stage Only)

AS CONSTRUCTED		
NO REVISIONS	REVISED <u>6-13-78</u>	VOID

FEDERAL ROAD REGION NO.	DIVISION	PROJ. NO.	SHEET NO.	TOTAL SHEETS
XIII	COLORADO	I 70-2(68) 197	15	31

REVISIONS		
<u>R-1</u>	5-9-77	ADDED NOTE

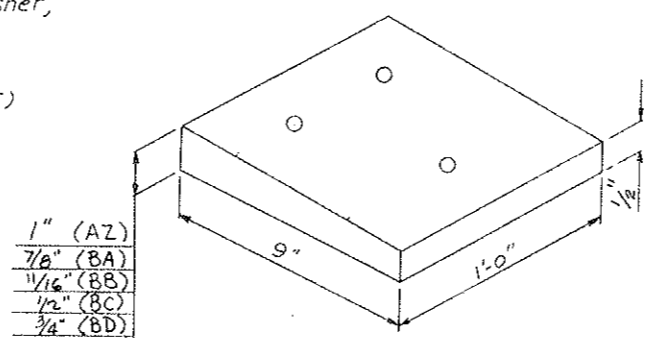
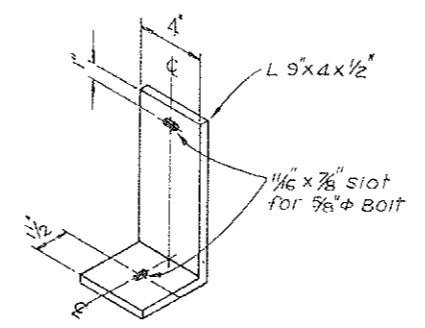
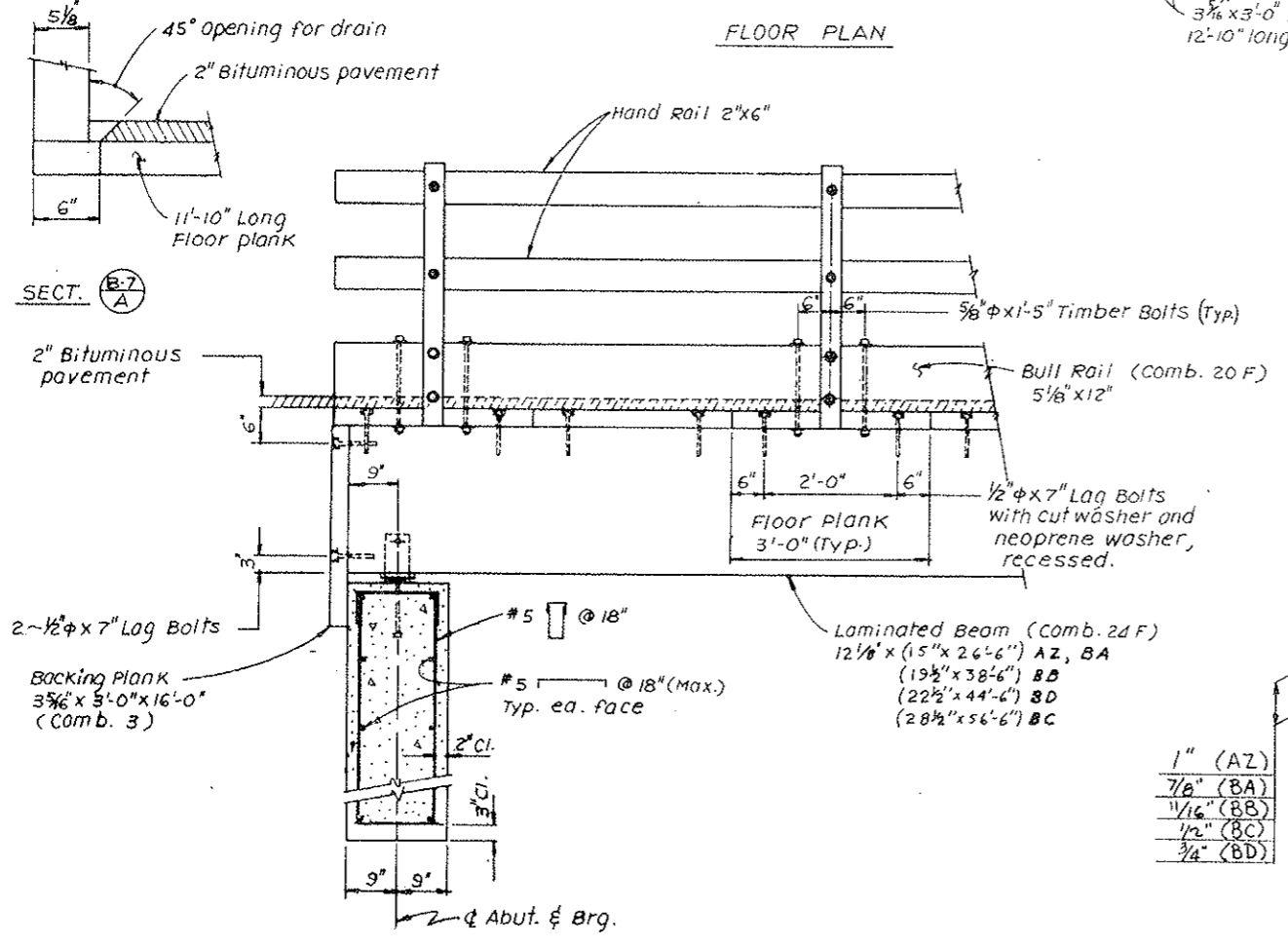
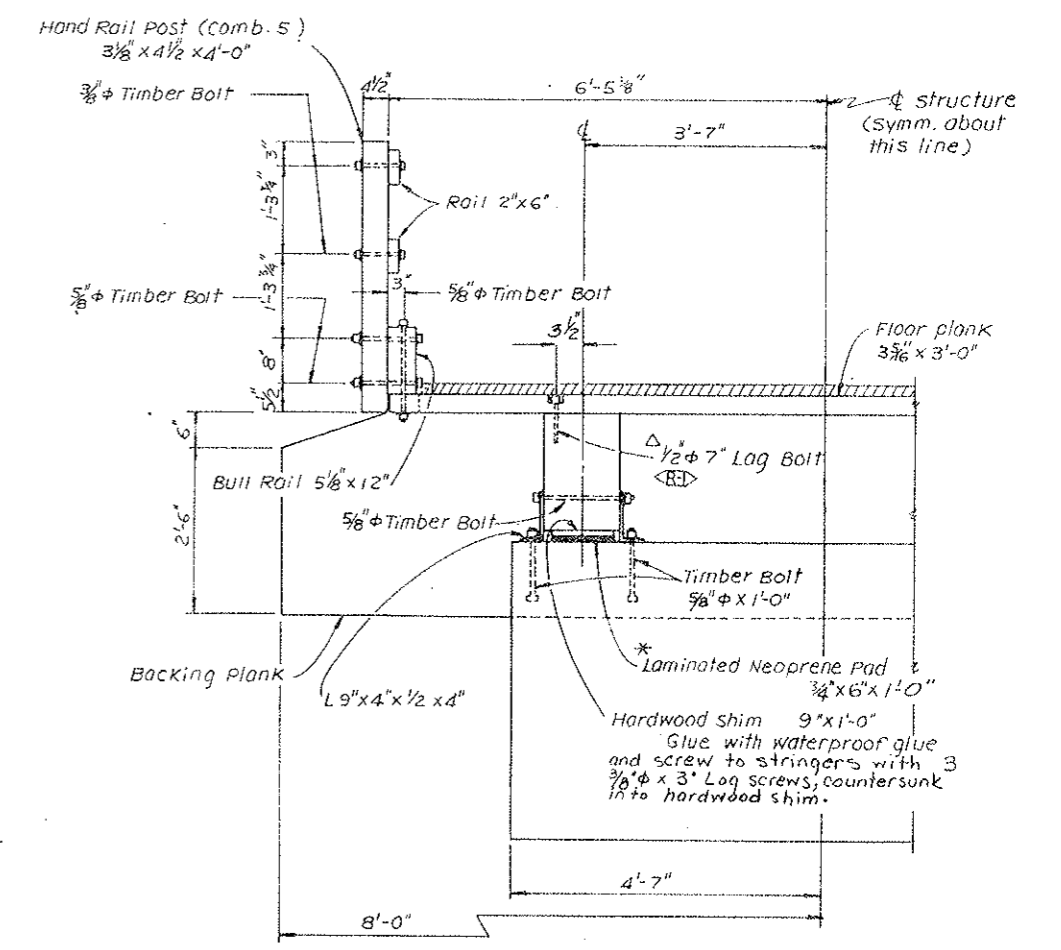
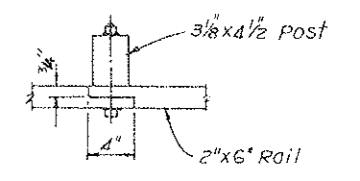
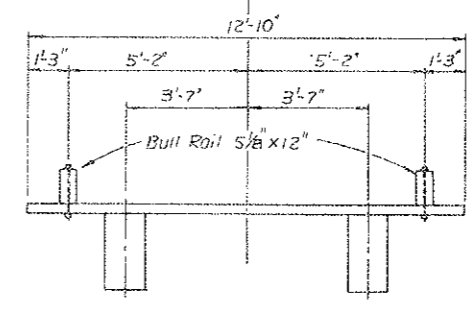
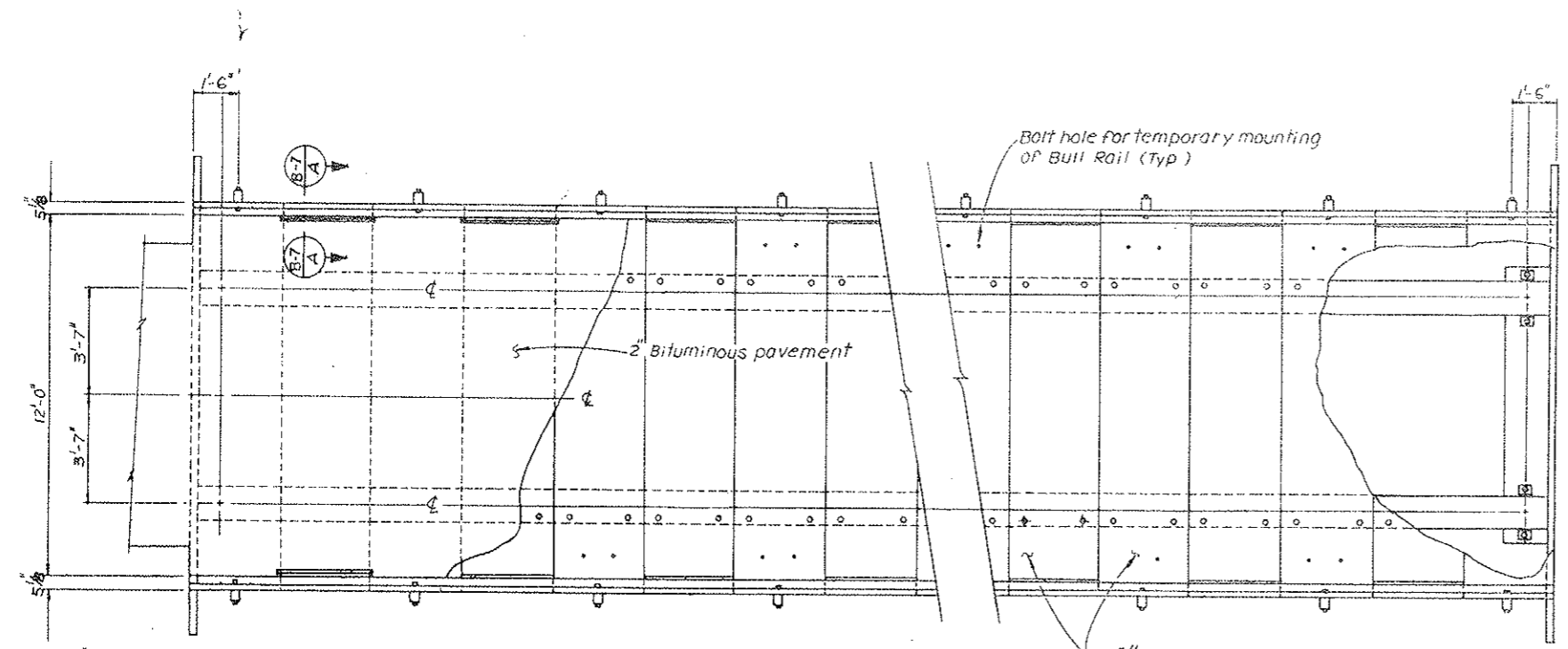

Footing pressure = 1.0 Ton/Sq. Ft. (AZ, BA)
1.3 Ton/Sq. Ft. (BB)
1.5 Ton/Sq. Ft. (BC)
1.9 Ton/Sq. Ft. (BD)

* Neoprene pad to be recessed 1/4" into concrete seat.
Δ ALTERNATE METHODS OF ATTACHING FLOOR PLANKS MAY BE SUBMITTED FOR APPROVAL.

DESIGNED BY	DATE	CHECKED BY	DATE
MLM	5-7-76	JLB	6-7-76
CHECKED BY	DATE	QUANTITIES BY	DATE
ALY	5-7-76	MLM	5-7-76
DETAILS BY	DATE		

DIVISION OF HIGHWAYS			
BRIDGE DETAILS			
Designer	M. L. McMullen	Structure	F-12-AZ, BA, BB,
Detailer	A. I. Takigiku	Numbers	BC, BD
Drawing Number	B 7	of	7 Drawings
Revision Dates	(Preliminary Stage Only)		

(R-1) 4-25-77, Note & Cable, WCB

PERSONNEL	DESIGN NO.	PROJECT NO.	DATE	SCALE
VIII	COLORADO	I 70-2(68)197	16	31

AS CONSTRUCTED	
NO REVISIONS	REVISED 6-12-78

(R-1) NOTE: Alignment and profile grade shown are preliminary. Alignment and grade shall be adjusted on construction to better fit the terrain. This may include the construction of switchbacks in order to reduce the grade.

All P.I.'s are to have curves. Minimum radius shall be 20 feet, desirable minimum radius is 70 feet. Curves will be superelevated as directed, maximum rate is 0.08'/ft.

E.B.
 Δ_s 28° 59' 00" Lt.
 T_s 1334.91'
 E_s 151.41'
 Δ_c 25° 14'
 T_c 1025.97'
 L_c 2018.67'
 R_c 4583.662'
 $S = 0.056$ /ft.
 $MDS = 60$ mph
 $SSD > 900'$

W.B.
 Δ_s 34° 09' 00" Lt.
 T_s 833.22'
 E_s 767.36'
 Δ_c 21° 24'
 T_c 360.87'
 L_c 713.33'
 R_c 1909.859'
 $S = 0.078$ /ft.
 $MDS = 70$ mph
 $SSD > 900'$

θ_s 5' 15"
 L_s 350'
 L_1 333.63'
 L_2 233.44'
 $S.T. 1$ 166.94'
 $S.T. 2$ 116.76'

θ_s 1° 52' 30"
 L_s 300'
 L_1 200.01'
 $S.T.$ 100.01'

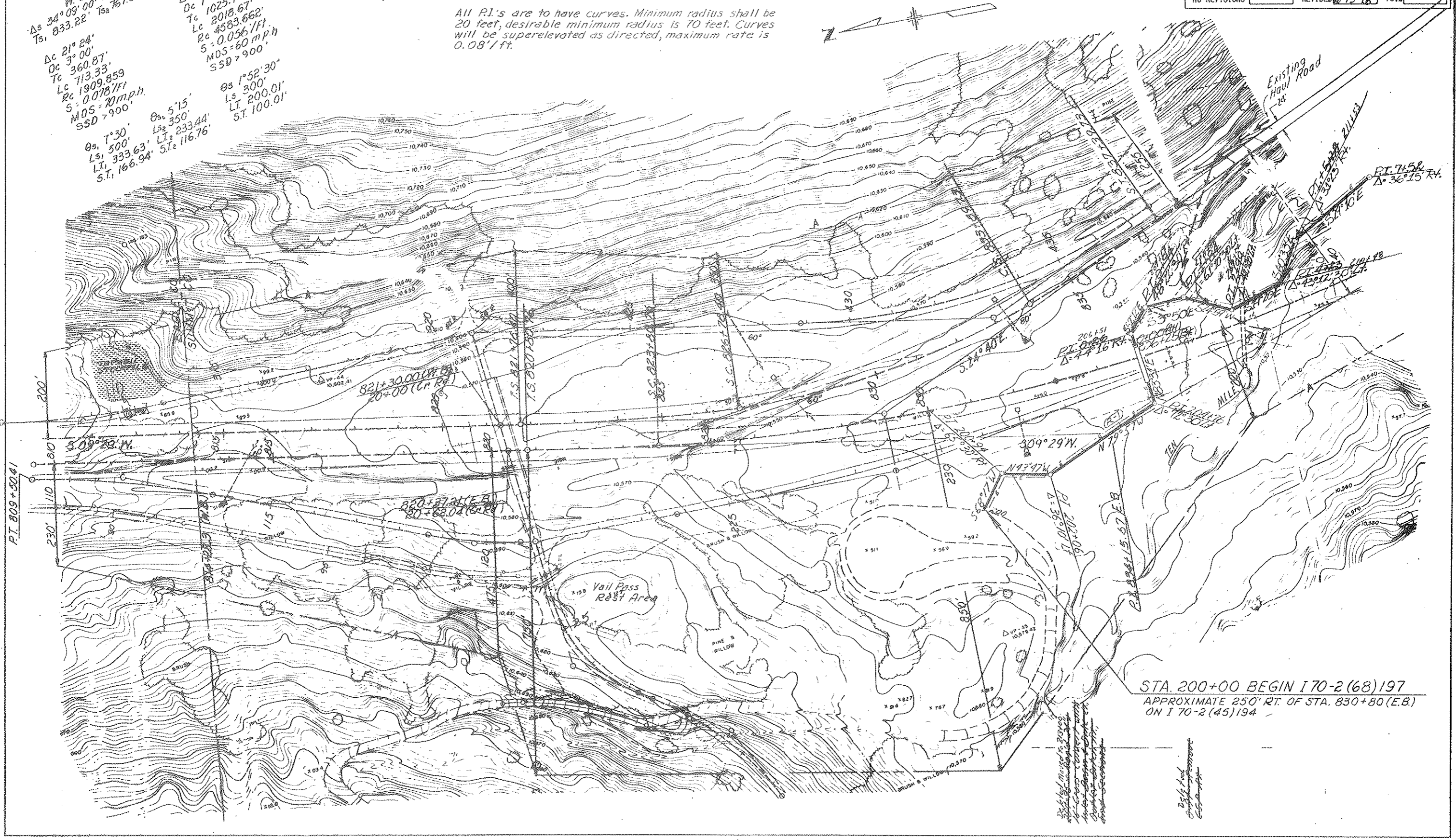

STA. 200+00 BEGIN I 70-2(68)197
 APPROXIMATE 250' RT. OF STA. 830+80 (E.B.)
 ON I 70-2(45)194

AS CONSTRUCTED		FEDERAL ROAD REGION NO.	DIVISION	PROJ. NO.	SHEET NO.	TOTAL SHEETS
NO REVISIONS	REVISED 6-13-83	VI 11	COLORADO	I 70-2(62)197	18	31

(R-1) 4-25-77, Alignment & Cable, WCB

Sta. 29+08.5 to 29+35.5 in Req'd Bridge.
 SH No F-12-A2 (See Details)

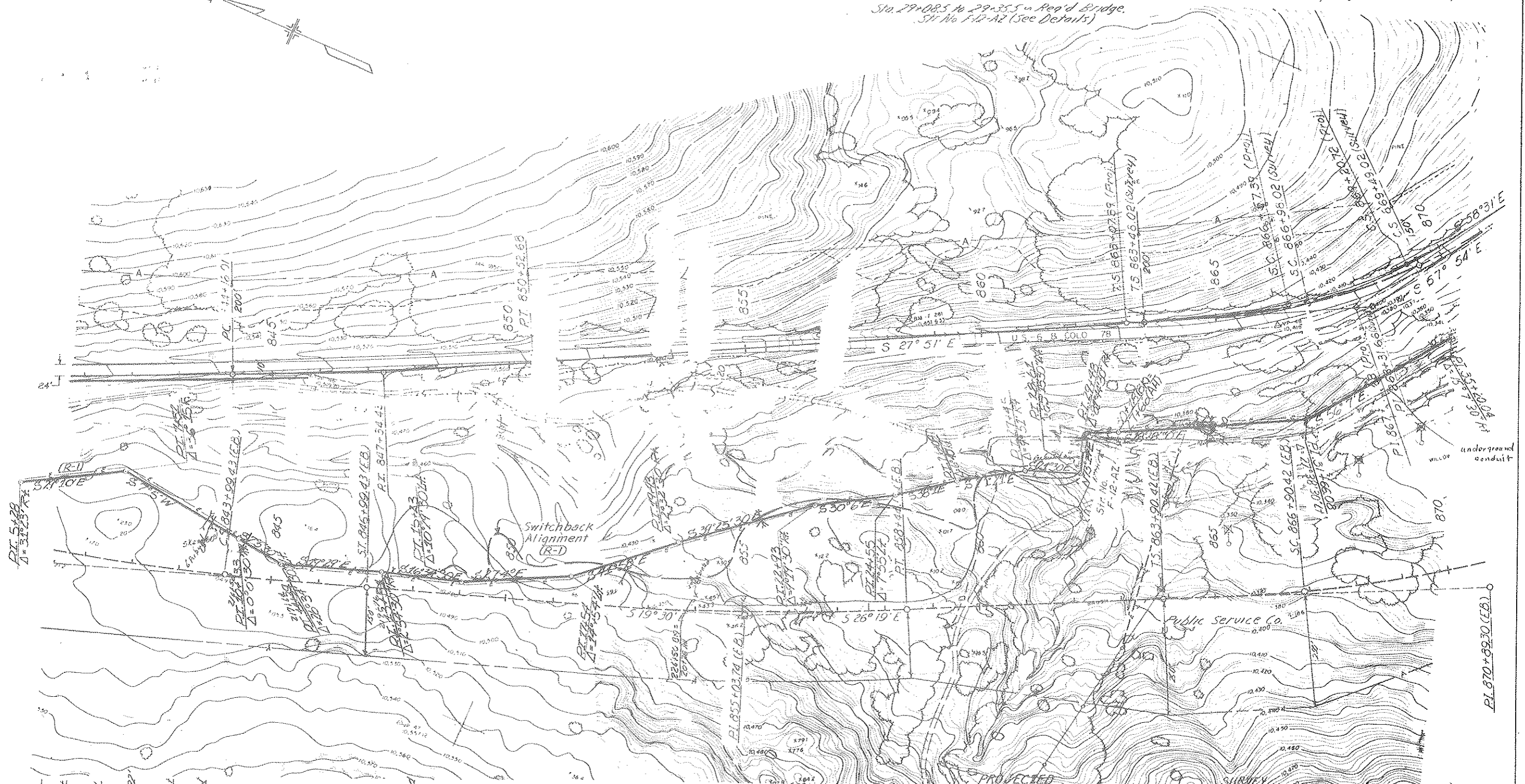
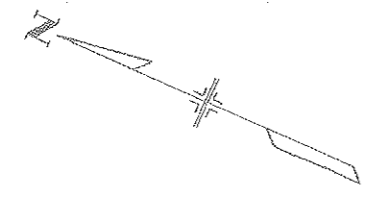

213100 24" x 24" Cross Culvert
 213100 24" x 24" Cross Culvert
 213100 24" x 24" Cross Culvert
 213100 24" x 24" Cross Culvert
 213100 24" x 24" Cross Culvert
 213100 24" x 24" Cross Culvert

Δc 3° 11' 00" Lt
 Δc 0° 30'
 Tc 318.42'
 Lc 636.67'
 Rc 11459.156
 Ea 4.42'
 TL 200.00'
 e 0.015 1/ft
 M.D.S.
 S.S.D.

213100 24" x 24" Cross Culvert
 213100 24" x 24" Cross Culvert
 213100 24" x 24" Cross Culvert
 213100 24" x 24" Cross Culvert
 213100 24" x 24" Cross Culvert

224850 24" x 24" Cross Culvert
 224850 24" x 24" Cross Culvert

224850 24" x 24" Cross Culvert
 224850 24" x 24" Cross Culvert
 224850 24" x 24" Cross Culvert

224850 24" x 24" Cross Culvert
 224850 24" x 24" Cross Culvert

PROJECTED
 Δ 30° 40' 00" Lt Os 8° 45'
 Is 490.79' Ls 350'
 Es 46.89' Lt 233.62'
 St 116.93'
 Δc 13° 10'
 Δc 5° 00'
 Tc 132.18'
 Lc 263.33'
 Rc 1145.916'
 e - 0.0601/ft
 M.D.S.
 S.S.D.

SURVEY
 Δ 30° 03' 00" Lt
 Os 8° 45'
 Is 483.64' Ls 350'
 Es 45.17' Lt 233.62'
 St 116.93'
 Δc 12° 33'
 Δc 5° 00'
 Tc 126.00'
 Lc 251.00'
 Rc 1145.916'
 e 0.060 1/ft
 M.D.S.
 S.S.D.

29+60.57 Req'd
 24" x 24" Cross Culvert
 41 Inlet Basin Bend
 Sections 44844

AS CONSTRUCTED
 NO REVISIONS 6-13-78 REVISED VOID

FEDERAL ROAD REGION NO.	DIVISION	PROJECT NO.	SHEET NO.
0000	COLORADO	170-2(68)197	19

DATE	BY
DATE	BY
DATE	BY
DATE	BY

DATE	BY
DATE	BY
DATE	BY
DATE	BY

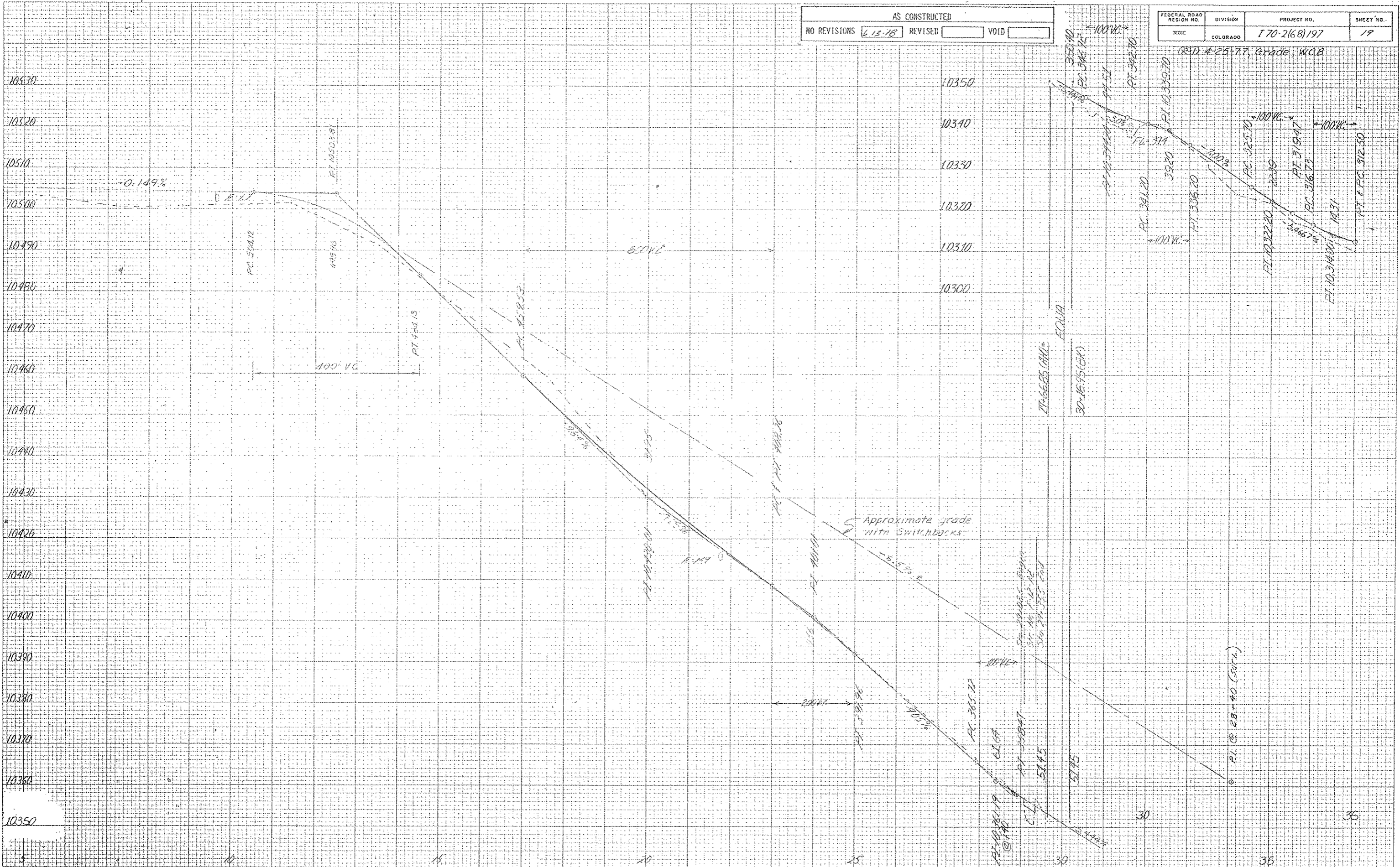
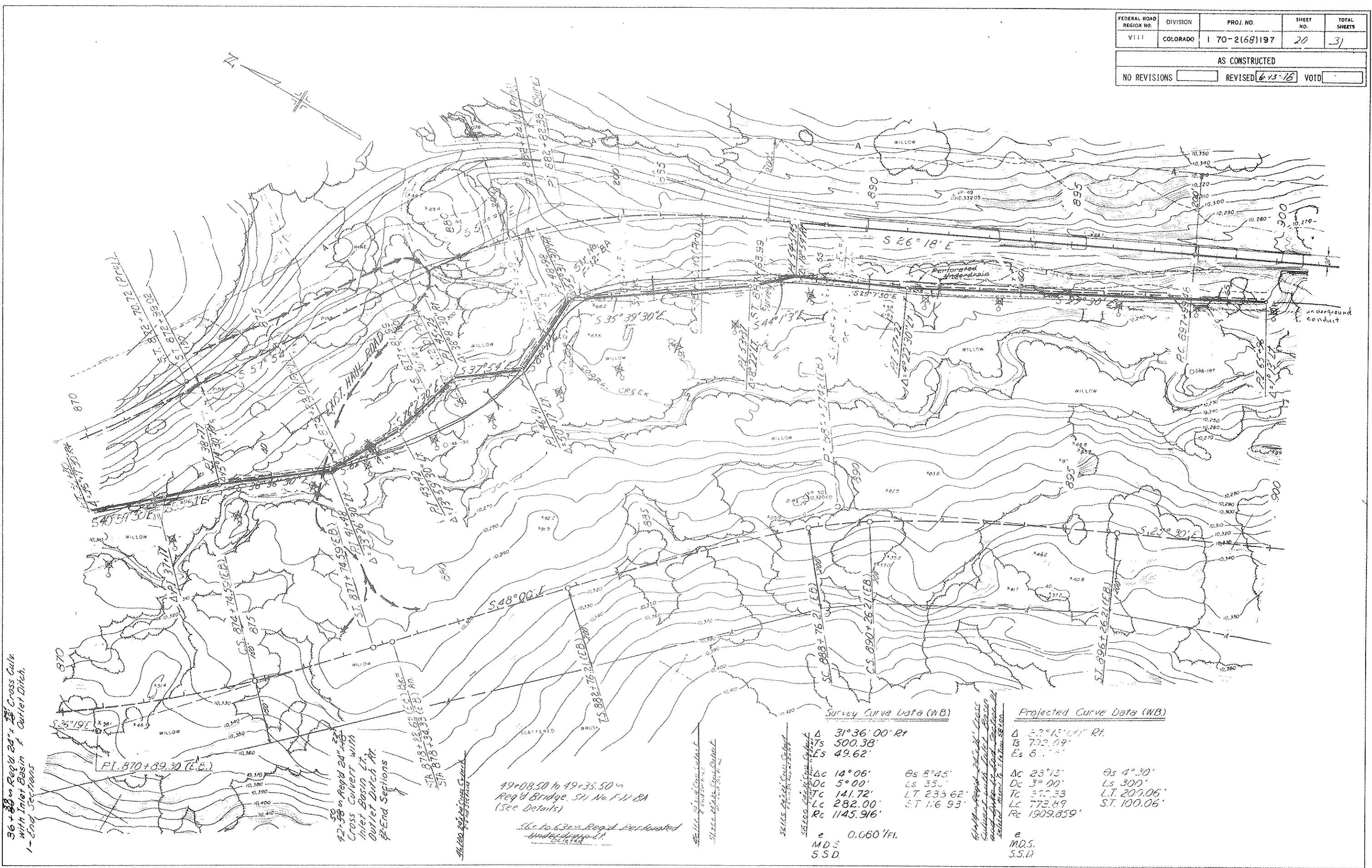

PLATE 2 - FULL CROSS SECTION
 CHARLES BRINKS COMPANY
 MADE IN U.S.A.

FEDERAL ROAD REGION NO.	DIVISION	PROJ. NO.	SHEET NO.	TOTAL SHEETS
VIII	COLORADO	1 70-2(68)197	20	31

AS CONSTRUCTED

NO REVISIONS	REVISED	VOID
	6-13-76	



36 + 88 m Reg'd 24" x 24" Cross Culv. with Inlet Basin & Outlet Ditch. 1- End Sections

42 + 58 m Reg'd 24" x 24" Cross Culvert with Inlet Basin Lt. Outlet Ditch Rt. 2- End Sections

49 + 08.50 to 49 + 35.50 m Reg'd Bridge. S11 No. F-11 BA (See Details)

56 to 63 m Reg'd Perforated Underdrain Lt.

Survey Curve Data (WB)

Δ	31° 36' 00" Rt	θ_s	5° 45'
Ts	500.38'	Ls	350'
Es	49.62'	Tc	235.62'
Δc	14° 06'	Lc	282.00'
Dc	5° 00'	Rc	1145.916'
Lt	141.72'	St	1:6 93'
Lc	282.00'		
Rc	1145.916'		
e	0.060' / Ft.		
M.D.S.			
S.S.D.			

Projected Curve Data (WB)

Δ	57° 18' 00" Rt.	θ_s	4° 30'
Ts	702.69'	Ls	300'
Es	61.12'	Tc	312.33'
Δc	23° 13'	Lc	773.89'
Dc	3° 00'	Rc	1909.859'
Lt	207.06'		
Lc	773.89'		
Rc	1909.859'		
e			
M.D.S.			
S.S.D.			

Underdrain to be installed in 5' to 6' from 56 + 00

See Note 1 of General Notes

All 24" Reg'd Cross Culverts

FEDERAL ROAD REGION NO.	DIVISION	PROJECT NO.	SHEET NO.
XIII	COLORADO	I 70-2(68)/97	21

AS CONSTRUCTED

NO REVISIONS 6-13-78 REVISIONS VOID

DATE	BY

FINAL SURVEY
 PLANTING
 NOTE BOOK
 AREA CHECKED

DATE	BY

ORIGINAL SURVEY
 PLANTING
 NOTE BOOK
 AREA CHECKED

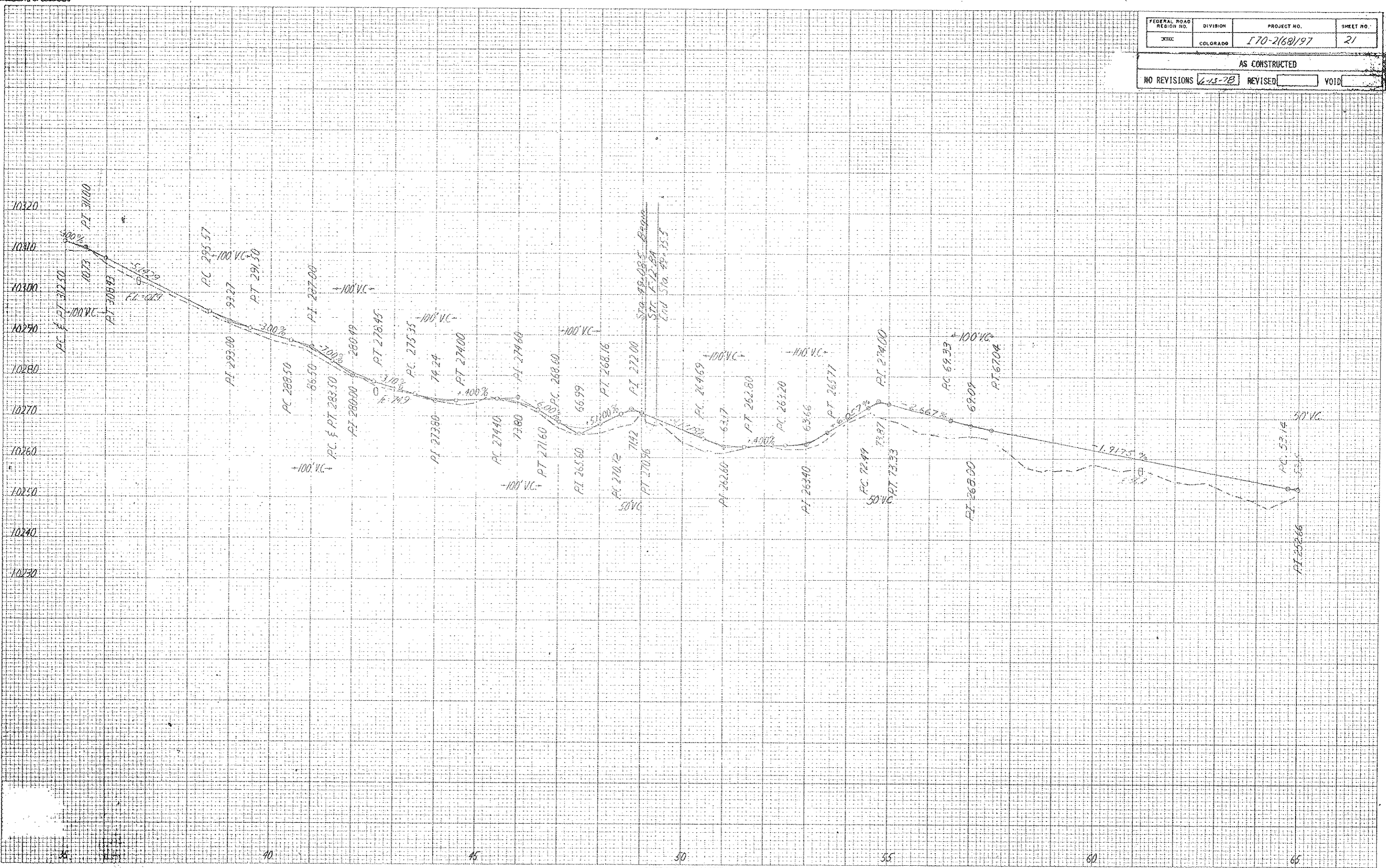

FEDERAL ROAD REGION NO.	DIVISION	PROJ. NO.	SHEET NO.	TOTAL SHEETS
VIII	COLORADO	170-2(68)197	22	31

AS CONSTRUCTED

NO REVISIONS REVISED VOID

(K-D) 4-25-77, Alignment, WCB

Δc 1° 55' 00" R/L
 Dc 0° 15'
 Tc 383.37'
 Lc 766.67'
 Rc 22918.312'
 Ec 3.20'
 e NC
 M.D.S.
 S.S.D.

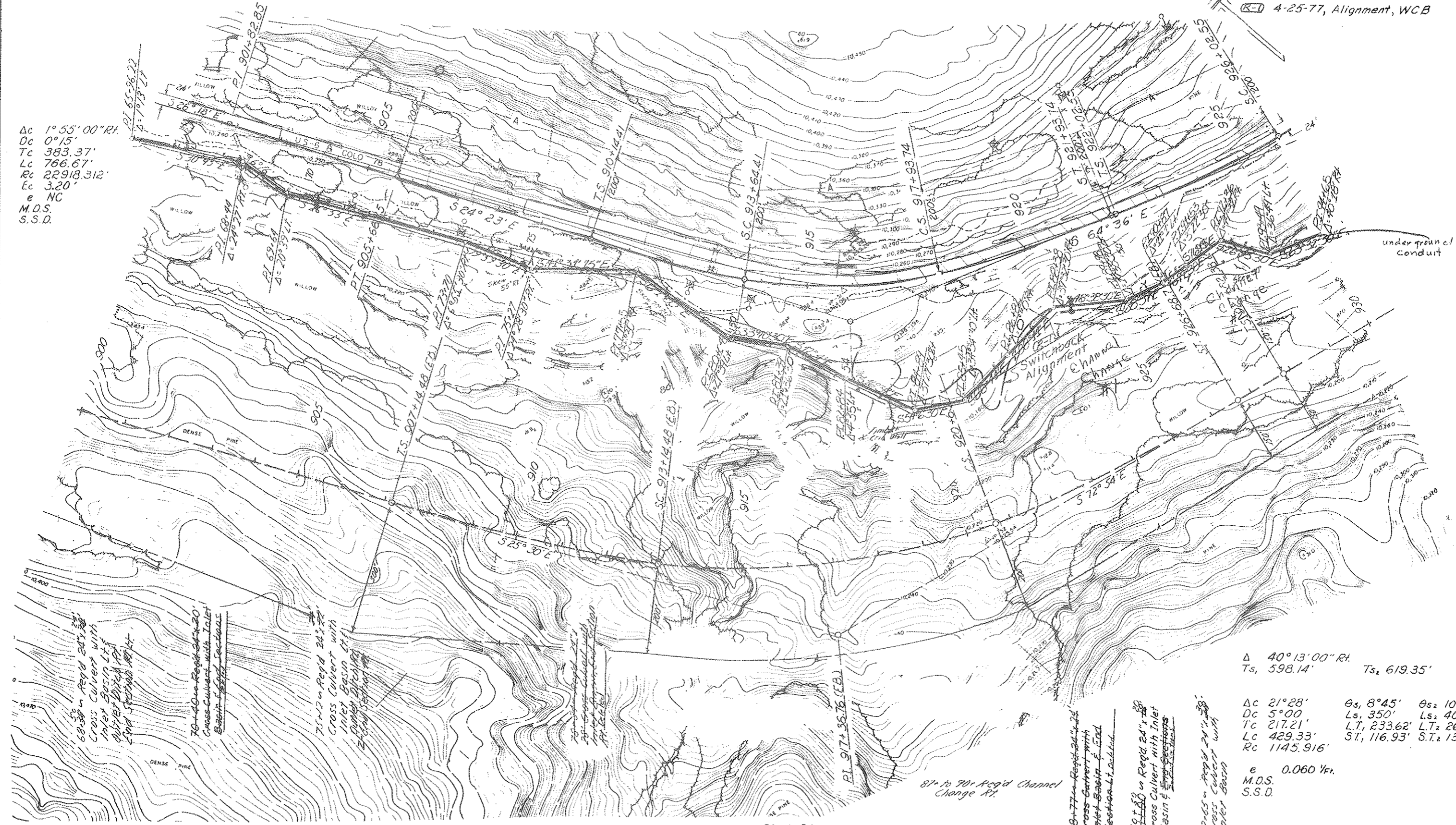

Δ 40° 13' 00" R/L
 Ts , 598.14' Ts , 619.35'

Δc 21° 28' θs , 8° 45' θs_2 10° 00'
 Dc 5° 00' Ls , 350' Ls_2 400'
 Tc 217.21' $L.T.$, 233.62' $L.T.$, 267.09'
 Lc 429.33' $S.T.$, 116.93' $S.T.$, 133.72'
 Rc 1145.916'

e 0.060 %/ft.
 M.D.S.
 S.S.D.

68-70 in Reg'd 24" x 24" Cross Culvert with Inlet Basin L/R
 70-72 in Reg'd 24" x 24" Cross Culvert with Inlet Basin L/R
 72-74 in Reg'd 24" x 24" Cross Culvert with Inlet Basin L/R

75-77 in Reg'd 24" x 24" Cross Culvert with Inlet Basin L/R
 77-79 in Reg'd 24" x 24" Cross Culvert with Inlet Basin L/R

80-82 in Reg'd 24" x 24" Cross Culvert with Inlet Basin L/R
 82-84 in Reg'd 24" x 24" Cross Culvert with Inlet Basin L/R

80-82 in Reg'd 24" x 24" Cross Culvert with Inlet Basin L/R
 82-84 in Reg'd 24" x 24" Cross Culvert with Inlet Basin L/R

88-90 in Reg'd 24" x 24" Cross Culvert with Inlet Basin L/R
 90-92 in Reg'd 24" x 24" Cross Culvert with Inlet Basin L/R

92-94 in Reg'd 24" x 24" Cross Culvert with Inlet Basin L/R
 94-96 in Reg'd 24" x 24" Cross Culvert with Inlet Basin L/R

96-98 in Reg'd 24" x 24" Cross Culvert with Inlet Basin L/R
 98-100 in Reg'd 24" x 24" Cross Culvert with Inlet Basin L/R

FEDERAL ROAD REGION NO.	DIVISION	PROJECT NO.	SHEET NO.
XIII	COLORADO	170-2(68)197	23
AS CONSTRUCTED			
NO REVISIONS		REVISED	VOID

(R-1) 4-25-76, Grade, WCB

DATE	BY

DATE	BY

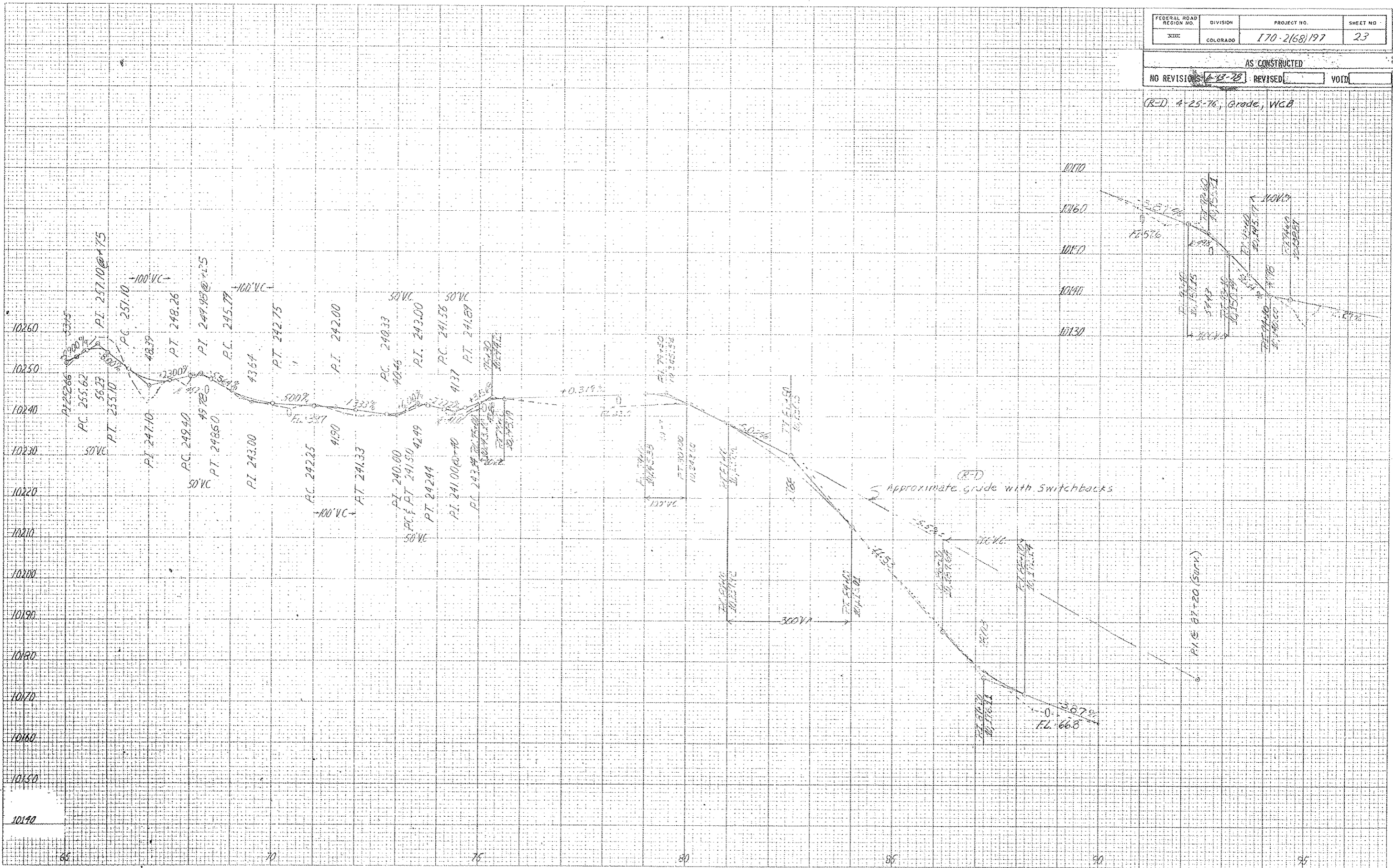

AS CONSTRUCTED		FEDERAL ROAD REGION NO.	DIVISION	PROJ. NO.	SHEET NO.	TOTAL SHEETS
NO REVISIONS	REVISED 6-13-28	VOID	VIII	COLORADO	170-21681197	21 31

Δ 34° 21' 00" Lt
 Ts 553.35' Ts 532.82'

 Δ c 15° 36'
 Dc 5° 00'
 Tc 156.97'
 Lc 312.00'
 Rc 1145.916

 θ s₁ 10° 00' θ s₂ 8° 45'
 Ls₁ 400' Ls₂ 350'
 LT₁ 267.09' LT₂ 233.62'
 ST₁ 133.72 ST₂ 116.93'

e 0.060 %/ft.
 M.D.S.
 S.S.D.



Str. No. F-12-88
 930
 140' x 140' 18"

Sta. 94+75.5 to 95+14.5
 Req'd Bridge, Str. No. F-12-88
 (See Details)

102+00 to 102+20
 Cross Culvert with Inlet Basin & End Section

109+00 to 109+20
 Cross Culvert with Inlet Basin, Outlet Ditch & End Sections

116+93.50 to 117+50.50
 Req'd Bridge, Str. No. F-12-88
 (See Details)

119+00 to 119+20
 Cross Culvert with Inlet Basin, Outlet Ditch & End Sections

124+40 to 124+20
 Cross Culvert with Inlet Basin, Outlet Ditch & End Sections

Δ 21° 24' 00" Rt
 Ts 691.54'
 Es 52.06'

 Δ c 15° 24' θ s 3° 00'
 Dc 2° 00' Ls 300'
 Tc 387.34' LT 200.03'
 Lc 770.00' ST 100.03'
 Rc 2864.789'

 e 0.060 %/ft.
 M.D.S.
 S.S.D.

126+57.50 to 127+02.50
 Req'd Bridge, Str. No. F-12-88
 (See Details)

FEDERAL ROAD REGION NO.	DIVISION	PROJECT NO.	SHEET NO.
3200	COLORADO	I 70-2(68)197	25

AS CONSTRUCTED
 NO REVISIONS 68-78 REVISIONS VOID

DATE	BY

DATE	BY

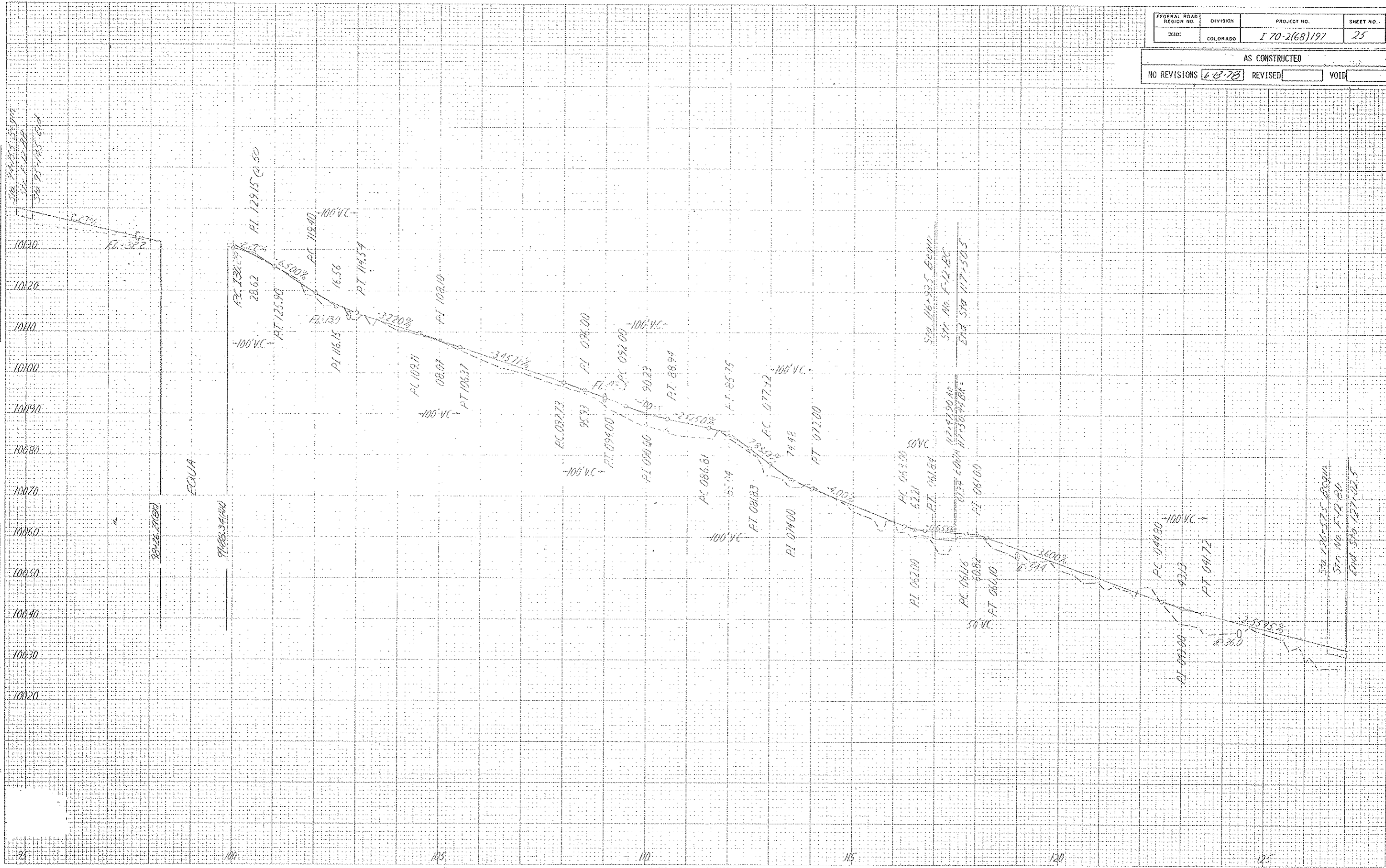

FEDERAL ROAD DISTRICT NO.	DIVISION	PROJ. NO.	SHEET NO.	TOTAL SHEETS
VIII	COLORADO	170-2(68)107	26	31
AS CONSTRUCTED				
NO REVISIONS		REVISED 6-15-22	VOID	

139' to 141' in Reg'd Channel Change Rt. 14940 150
 1983-78-1442 in Reg'd Timber Crib Wall Rt.



139' to 141' in Reg'd Channel Change Rt.
 1983-78-1442 in Reg'd Timber Crib Wall Rt.

Δc 2°49'00" Lt
 Δc 0°15'
 Tc 563.45'
 Lc 1126.67'
 Rc 22,918.312
 Es 6.92'

e NC
 M.D.S.
 S.S.D.

131' x 24' in Reg'd
 24' x 32' Cross
 Culvert End Sections

122' x 20' in Reg'd
 24' x 20' Cross
 Culvert with
 Inlet Basin Lt
 2-End Sections

128' x 20' in Reg'd
 24' x 22' Cross Culvert
 with Inlet Basin f
 2-End Sections

Δ 22°29'00" Rt
 Ts 378.33'
 Es 25.77'

θs 7°30'
 Ls 300'
 Lt 200.18'
 S.T. 100.16'

Δc 7°29'
 Δc 5°00'
 Tc 74.94'
 Lc 149.67'
 Rc 1145.916'

e 0.060 1/ft
 M.O.S.
 S.S.D.

144' x 20' in Reg'd
 42' x 26' Cross
 Culvert with
 Inlet Basin Lt f
 End Section 2-End Sections

159' x 20' in Reg'd
 24' x 21' Cross
 Culvert with
 Inlet Basin Lt f
 2-End Sections

Δ 27°16'00" Lt
 Ts 523.19'
 Es 45.23'

θs 7°00'
 Ls 350'
 Lt 233.52'
 S.T. 116.83'

Δc 13°16'
 Δc 4°00'
 Tc 166.58'
 Lc 331.67'
 Rc 1432.394'

e 0.060 1/ft
 M.O.S.
 S.S.D.

under your conduct

FEDERAL ROAD REGION NO. XIII	DIVISION COLORADO	PROJECT NO. I 70-2(68)197	SHEET NO. 27
---------------------------------	----------------------	------------------------------	-----------------

AS CONSTRUCTED

NO REVISIONS 13-78 REVISIONS VOID

DATE	
BY	
FINAL SURVEY	
NOTE BOOK	
AREA	
CHECKED	

DATE	
BY	
ORIGINAL SURVEY	
NOTE BOOK	
AREA	
CHECKED	

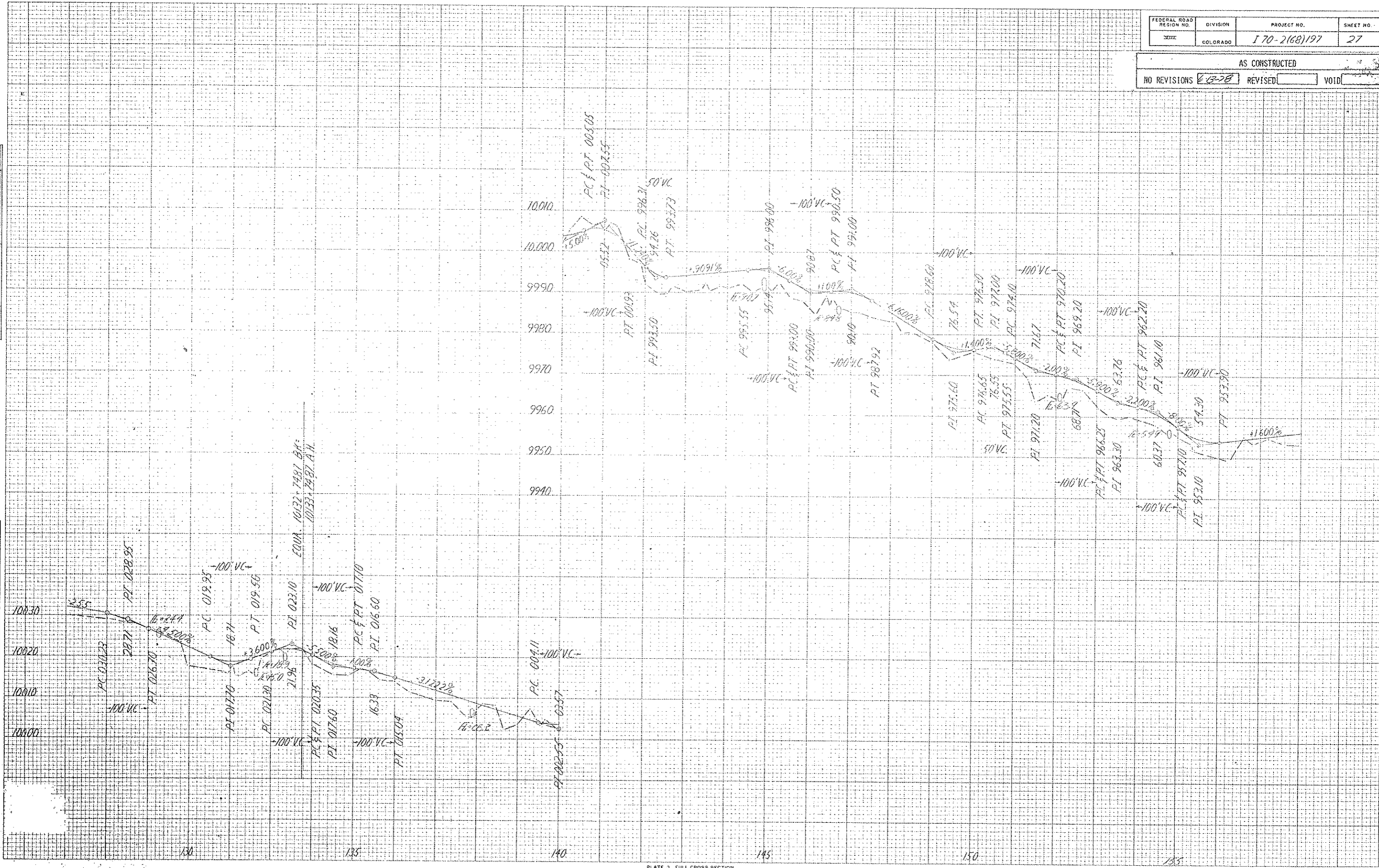
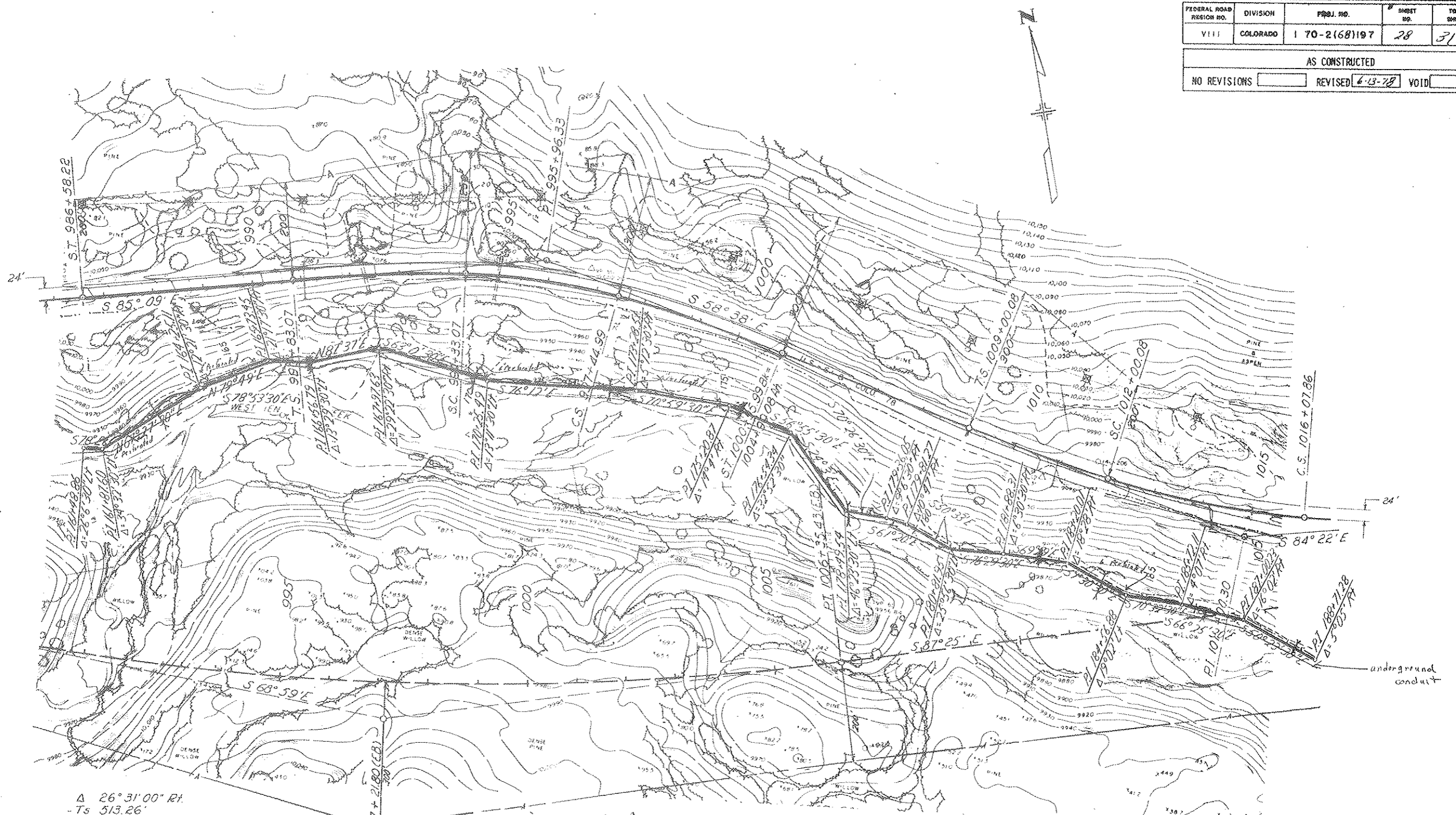

PLATE 3 FULL CROSS SECTION
 CHARLES BRUNING COMPANY
 MADE IN U.S.A.

FEDERAL ROAD DISTRICT NO.	DIVISION	PROJ. NO.	SHEET NO.	TOTAL SHEETS
VIII	COLORADO	170-2(68)197	28	31

AS CONSTRUCTED

NO REVISIONS REVISED 4-13-59 VOID



Δ 26° 31' 00" Rt.
 Ts 513.26'
 Es 42.88'

Δ c 12° 31' θ s 7° 00'
 Dc 4° 00' Ls 350'
 Tc 157.08' LT 233.52'
 Lc 312.92' ST 116.83'
 Rc 1432.394

e 0.060 %
 M.O.S.
 S.S.D.

166° to 147° in Reg'd. Timber
 Curb Wall, RL related

166+50 in Reg'd. Timber
 Curb Wall, RL related

170+00 in Reg'd. Timber
 Curb Wall, RL related

175+50 in Reg'd. Timber
 Curb Wall, RL related

180+00 in Reg'd. Timber
 Curb Wall, RL related

185+00 in Reg'd. Timber
 Curb Wall, RL related

190+00 in Reg'd. Timber
 Curb Wall, RL related

195+00 in Reg'd. Timber
 Curb Wall, RL related

200+00 in Reg'd. Timber
 Curb Wall, RL related

205+00 in Reg'd. Timber
 Curb Wall, RL related

210+00 in Reg'd. Timber
 Curb Wall, RL related

Δ 25° 44' 00" Lt.
 Ts1 600.22'
 Ts2 724.24'

Δ c 12° 14' θ s1 4° 30'
 Dc 3° 00' θ s2 9° 00'
 Tc 204.67' Ls1 300'
 Lc 407.78' Ls2 600'
 Rc 1909.859' LT1 200.06'

e 0.060 %
 M.O.S.
 S.S.D.
 LT2 400.52'
 ST1 100.06'
 ST2 200.47'

FEDERAL ROAD REGION NO.	DIVISION	PROJECT NO.	SHEET NO.
3400	COLORADO	I 70-2(68)197	29
AS CONSTRUCTED			
NO REVISION	<input checked="" type="checkbox"/> 13-28	REVISED	VOID

DATE
BY
NO.
NO.
NO.
NO.
NO.

DATE
BY
NO.
NO.
NO.
NO.
NO.
NO.

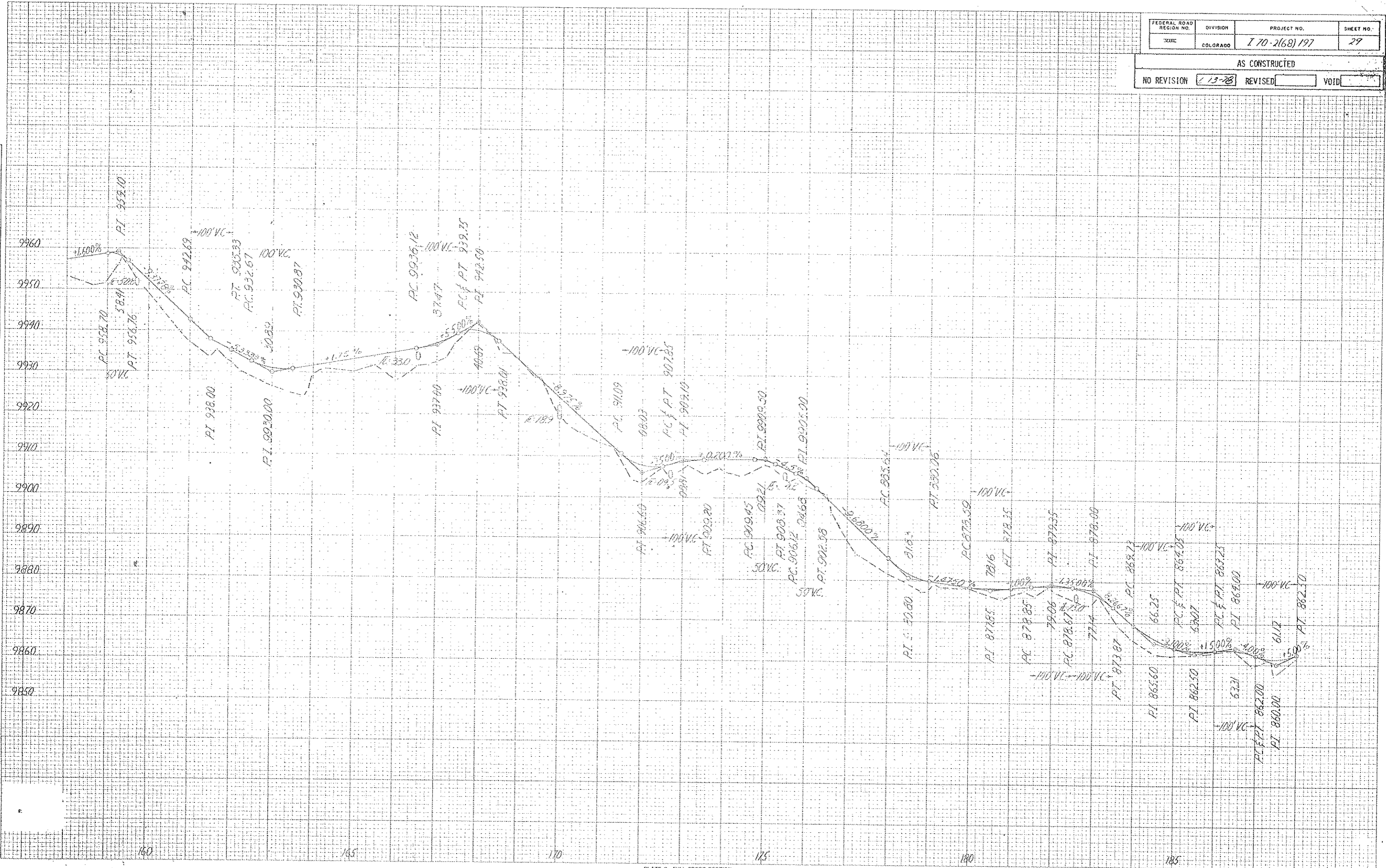

PLATE 3 FULL CROSS SECTION
CHARLES STUBBS COMPANY
MADE IN U.S.A.

AS CONSTRUCTED		FEDERAL ROAD REGION NO.	DIVISION	PROJ. NO.	SHEET NO.	TOTAL SHEETS
NO REVISIONS	REVISED 6-13-28	VOID	VIII	COLORADO	I 70-2(68)197	30
						31

W.B. PROJ.
 $\Delta s = 25^{\circ}44' Lt.$
 $Ts_1 = 600.2'$
 $Ts_2 = 724.2'$
 $\Delta c = 12^{\circ}14'$
 $Dc = 3^{\circ}00'$
 $Tc = 204.7'$
 $Lc = 407.8'$
 $Rc = 104.9'$
 $e = 0.060 \frac{1}{ft}$
 $SSD = 935'$
 $MDS = 75 mph$

W.B. PROJ.
 $\Delta s = 3^{\circ}30' Lt.$
 $Ts_1 = 671.1'$
 $Ts_2 = 589.9'$
 $\Delta c = 13^{\circ}30' Lt.$
 $Dc = 4^{\circ}00'$
 $Tc = 169.5'$
 $Lc = 337.5'$
 $Rc = 1432.4'$
 $e = 0.060 \frac{1}{ft}$
 $MDS = 65 mph$
 $SSD = 844'$

E.B. PROJ.
 $\Delta s = 26^{\circ}51' Lt.$
 $Ts_1 = 541.2'$
 $Ts_2 = 48.4'$
 $\Delta c = 16^{\circ}21' Lt.$
 $Dc = 3^{\circ}30'$
 $Tc = 235.2'$
 $Lc = 467.1'$
 $Rc = 1637.0'$
 $e = 0.073 \frac{1}{ft}$
 $MDS = 70 mph$
 $SSD = 657'$

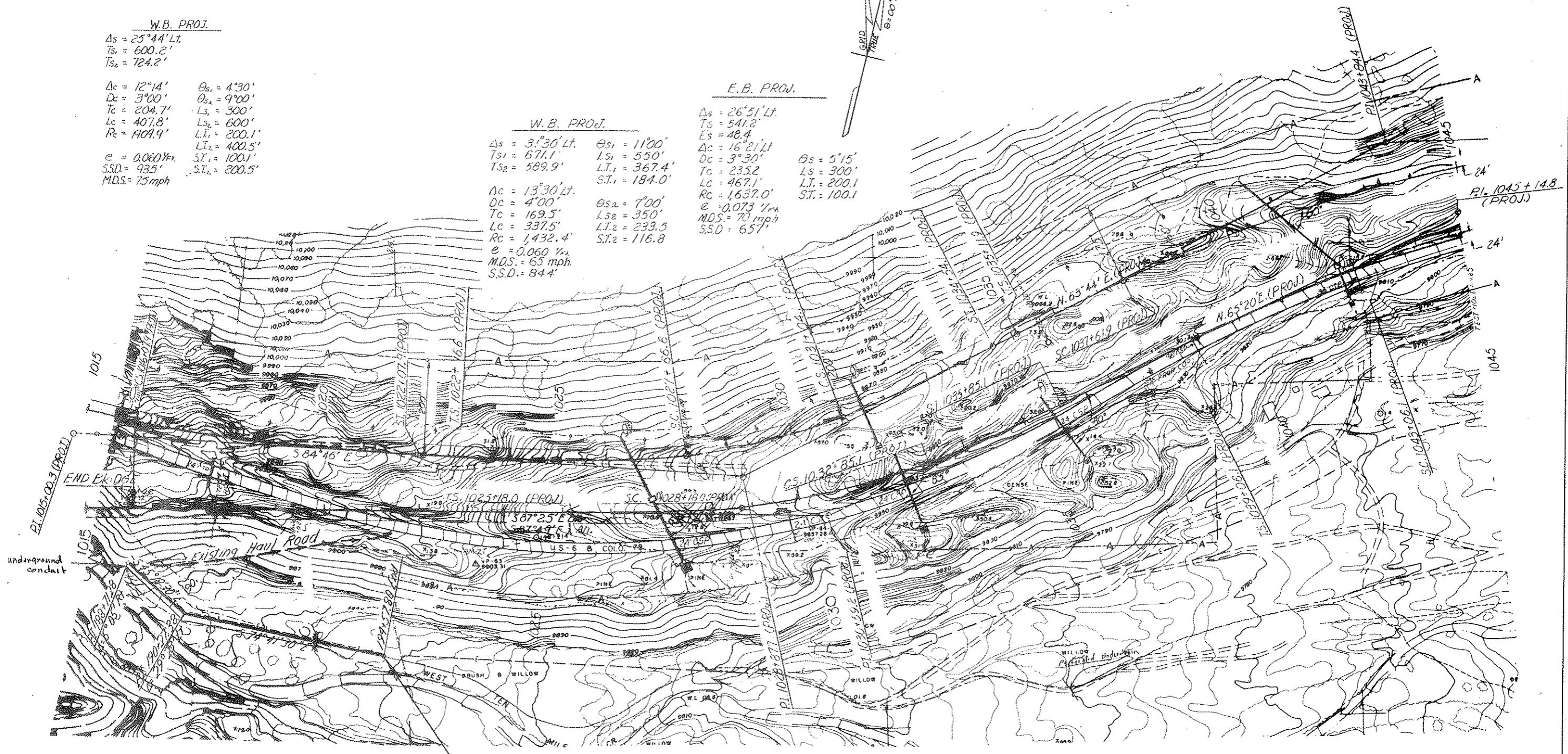
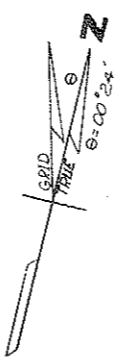

STA. 194+57.80 END I 70-2(68)197
 APPROXIMATE 310' RT. OF STA. 1021+30 (E.B.)
 ON I 70-2(44)200

193+05 - Road
 24' x 18' - Cross-Collector
 with 12" Bit Basins at End
 Sections 2, 1, 2

C. H. Moore, M. E.
 Eng. & Surveyor
 600 S. Grand Ave.

FEDERAL ROAD REGION NO.	DIVISION	PROJECT NO.	SHEET NO.
3333	COLORADO	I 70-2(68)197	31

AS CONSTRUCTED

NO REVISIONS 12-73 REVISED VOID

DATE	BY

DATE	BY

