

**SLOT DETAIL**

**ALTERNATE SLOT AND HOLD DOWN PLATE DETAIL**

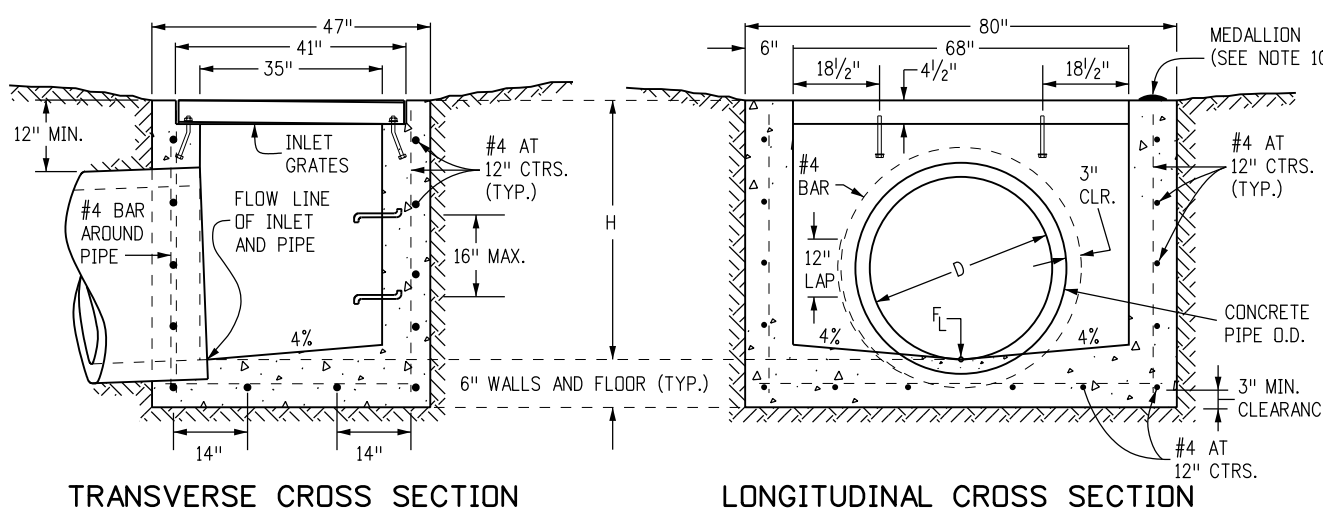

**TRANSVERSE CROSS SECTION**

**LONGITUDINAL CROSS SECTION**

**LEVEL GRATE INSTALLATION**

- GENERAL NOTES**
1. INLET TYPE D IS NOT HS-20 RATED AND SHALL NOT BE PLACED IN PAVED ROADWAYS. THIS INLET SHALL BE USED ONLY OUTSIDE PAVED ROADWAYS.
  2. CONCRETE SHALL BE CLASS B. INLET MAY BE CAST-IN-PLACE OR PRECAST.
  3. SEE PLANS FOR SIZE AND LOCATION OF PIPE.
  4. STRUCTURAL STEEL FOR GRATES AND GRATE INSTALLATION HARDWARE SHALL BE GALVANIZED AND SHALL BE IN ACCORDANCE WITH SUBSECTION 712.06.
  5. STANDARD INLET GRATES SHALL BE USED ON ALL TYPE D INLETS UNLESS CLOSE MESH GRATES ARE SPECIFIED ON THE PLANS.
  6. CLOSE MESH GRATES ARE RECOMMENDED WHERE FOOT TRAFFIC OR BICYCLE ROUTES ARE IN CLOSE PROXIMITY TO GRATE. THIS GRATE IS NOT ADA COMPLIANT OR BICYCLE FRIENDLY AND SHALL NOT BE PLACED DIRECTLY IN SIDEWALKS, CROSSWALKS OR BIKE PATHS.
  7. STEPS SHALL BE PROVIDED WHEN INLET DIMENSION "H" IS EQUAL TO OR GREATER THAN 3 FEET-6 INCHES AND SHALL CONFORM WITH AASHTO M 199.
  8. REINFORCING BARS SHALL BE GRADE 60, EPOXY COATED, AND DEFORMED #4, AND SHALL HAVE A 2 INCH MIN. CLEARANCE. CUT OR BEND BARS AROUND PIPE AS REQUIRED.
  9. ALL INLETS SHALL HAVE A 4 INCH DIA. METAL MEDALLION WITH A "NO DUMPING DRAINS TO STREAM" MESSAGE ON IT. THE MEDALLION SHALL HAVE A FISH SYMBOL WITH A BLUE BACKGROUND. IT SHALL BE FIRMLY ATTACHED TO THE INLET'S SURFACE WITH A PERMANENT FASTENER.

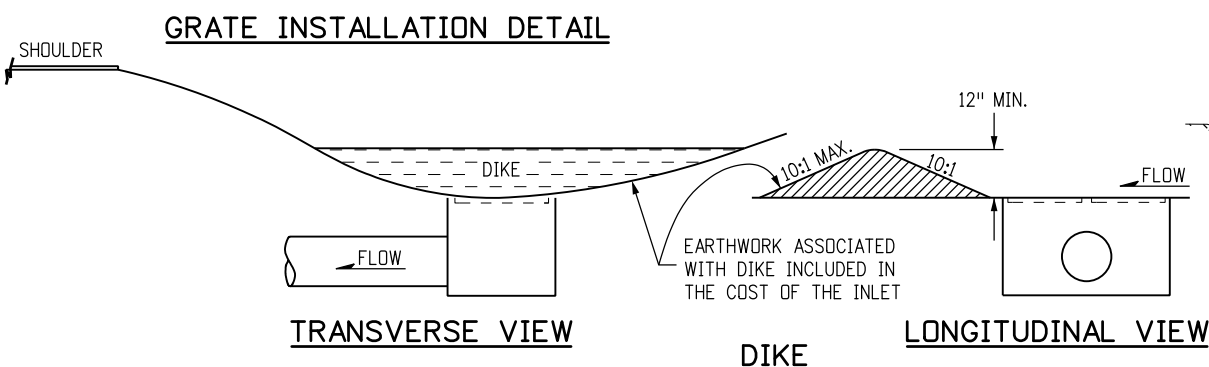

**GRATE INSTALLATION DETAIL**

**TRANSVERSE VIEW**

**LONGITUDINAL VIEW**

**DIKE**

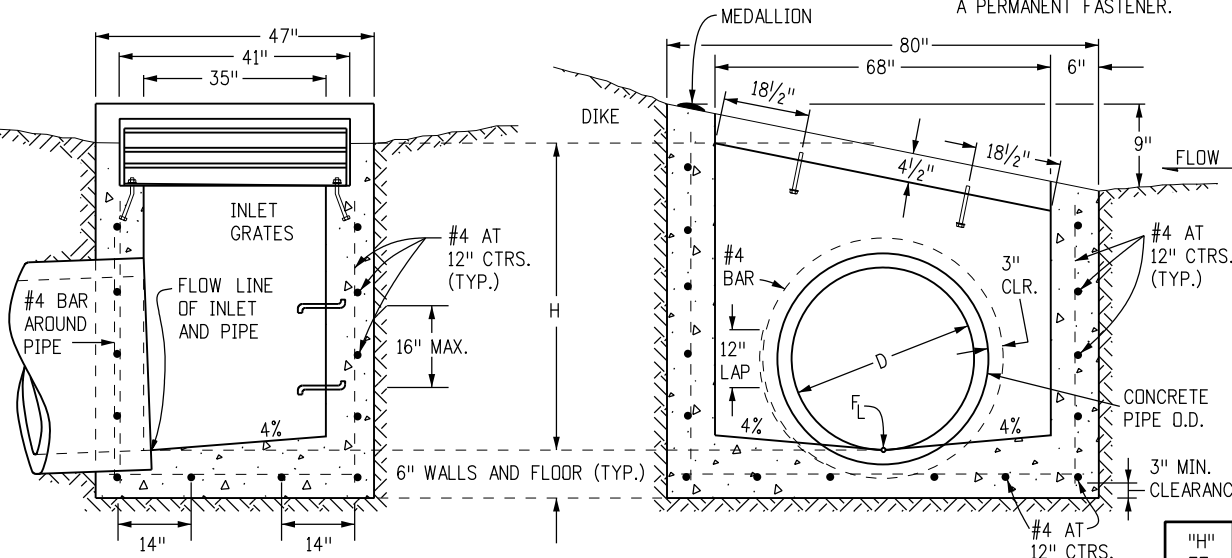

**TRANSVERSE CROSS SECTION**

**LONGITUDINAL CROSS SECTION**

**SLOPING GRATE INSTALLATION**

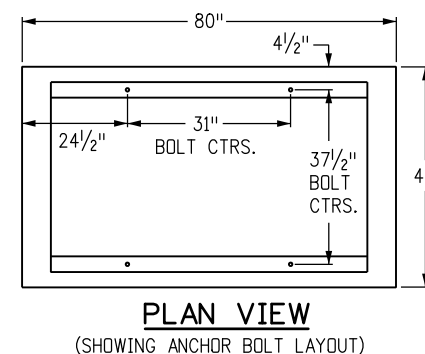

**PLAN VIEW**

(SHOWING ANCHOR BOLT LAYOUT)

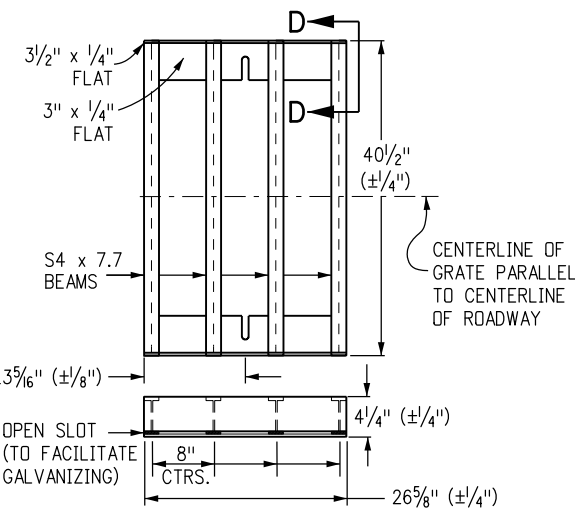

**STANDARD INLET GRATE**

**TWO STEEL GRATE PER INLET QUANTITIES**

NO. PIECES	DESCRIPTION	LENGTH	LBS PER FT.	WEIGHT (LBS.)
8	S4 x 7.7 BEAM	40"	7.70	206
4	3 1/2" x 1/4" FLAT	26 5/8"	2.98	26
4	3" x 1/4" FLAT	26 5/8"	2.55	24

TOTAL LBS. - 256

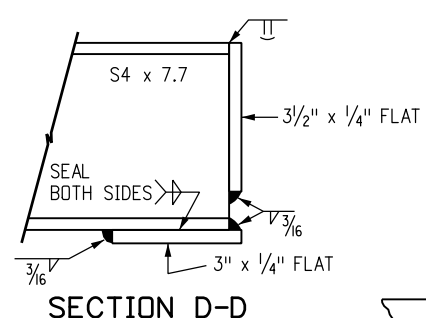

**SECTION D-D**

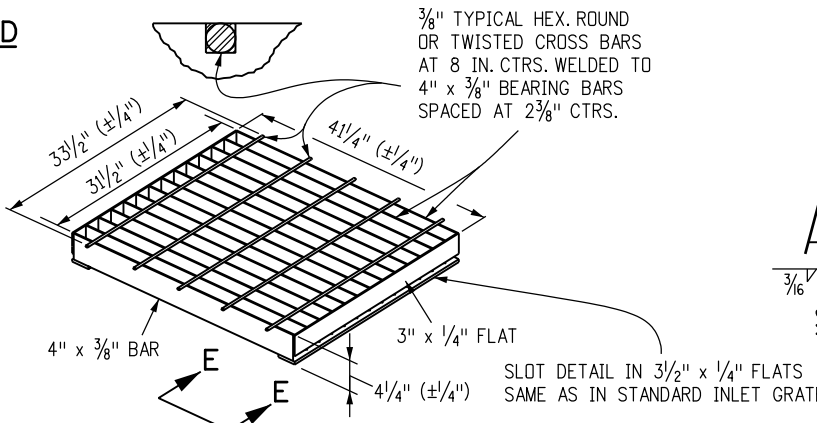

**CLOSE MESH GRATE**

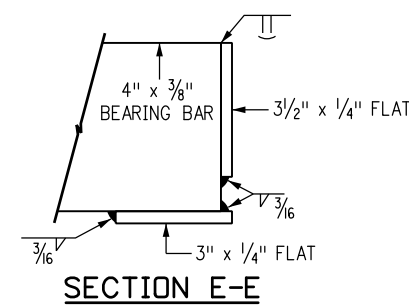

**SECTION E-E**

OUTLET PIPE INSIDE DIA. FT. - "D"	MIN. "H" FT.
1.5	3.0
2.0	3.5
2.5	4.0
3.0	4.5
3.5	5.0

"H" FT.	CONCRETE CU. YDS.	STEEL LBS.	CIRCULAR PIPE RANGE
			INSIDE DIA., IN. - "D"
3.0	1.5	127	18
3.5	1.7	149	18-24
4.0	1.9	157	18-30
4.5	2.0	179	18-36
5.0	2.2	187	18-42
5.5	2.4	208	18-42
6.0	2.6	215	18-42
6.5	2.8	236	18-42
7.0	2.9	243	18-42
7.5	3.1	264	18-42
8.0	3.3	271	18-42
8.5	3.5	292	18-42
9.0	3.6	299	18-42
9.5	3.8	320	18-42
10.0	4.0	327	18-42

CONCRETE AND STEEL QUANTITIES ARE FOR ONE ENTIRE INLET BEFORE DEDUCTION FOR VOLUME OCCUPIED BY PIPE. WEIGHT OF STEEL INCLUDES A RING FOR THE MAXIMUM PIPE DIAMETER.

**QUANTITIES FOR ONE INLET**

**Computer File Information**

Creation Date: 07/31/19	(R-X)
Designer Initials: JBK	(R-X)
Last Modification Date: 07/31/19	(R-X)
Detailer Initials: LTA	(R-X)
CAD Ver.: MicroStation V8 Scale: Not to Scale Units: English	(R-X)

**Sheet Revisions**

Date:	Comments

**Colorado Department of Transportation**

2829 West Howard Place  
 CDDT HQ, 3rd Floor  
 Denver, CO 80204  
 Phone: 303-757-9021 FAX: 303-757-9868

Project Development Branch **JBK**

**INLET, TYPE D**

Issued by the Project Development Branch: July 31, 2019

**STANDARD PLAN NO.**

M-604-11

**Standard Sheet No. 1 of 1**

Project Sheet Number: