

★ FOR LENGTH (L) 10 FT. OR MORE, PROVIDE MAINTENANCE ACCESS AT BOTH ENDS WITH AN ADDITIONAL MANHOLE RING AND COVER. CUT REINFORCEMENT BAR ACCORDINGLY.

◆ STATION POINT AT MIDPOINT OF INLET ALONG FLOWLINE

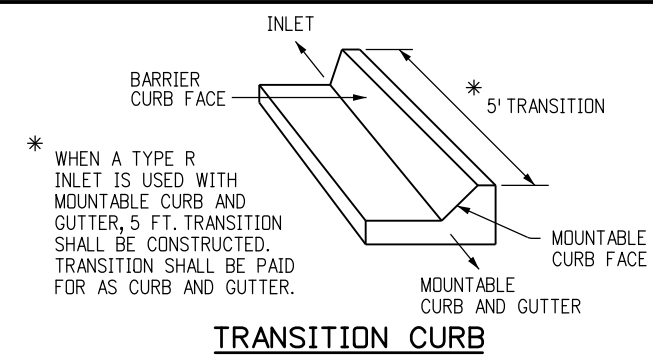

**GENERAL NOTES:**  
SEE SHEET 2.

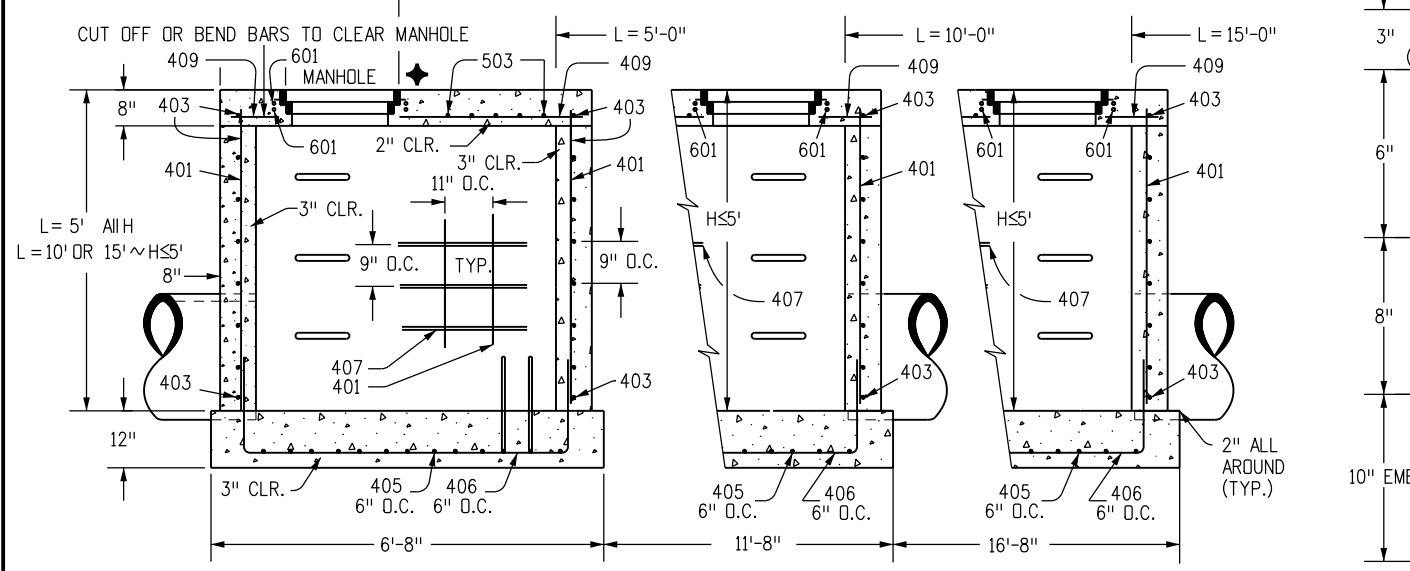

SECTION A-A REGULAR INLET

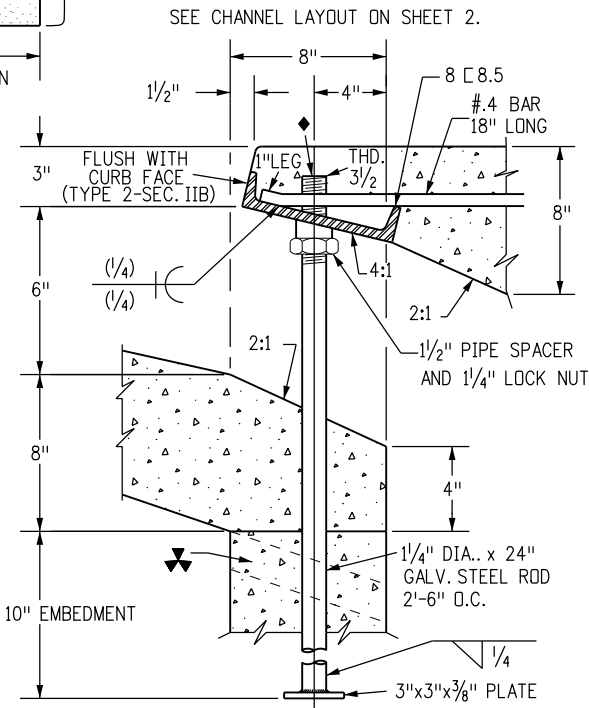

CURB FACE ASSEMBLY

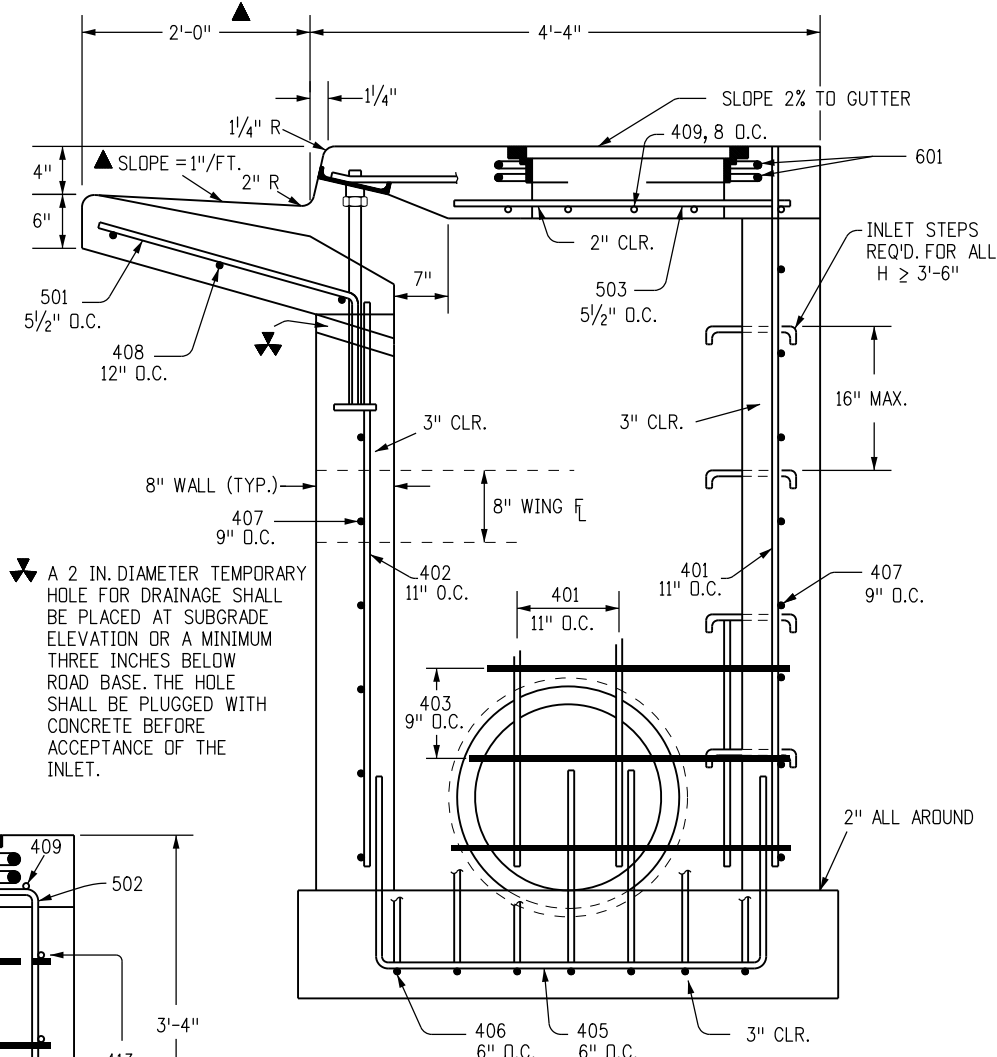

SECTION B-B  
END VIEW

NOTE: MANHOLE RING AND COVER, STATION POINT AND OUTFLOW PIPE SHALL BE LOCATED AT THE SAME END OF THE INLET.

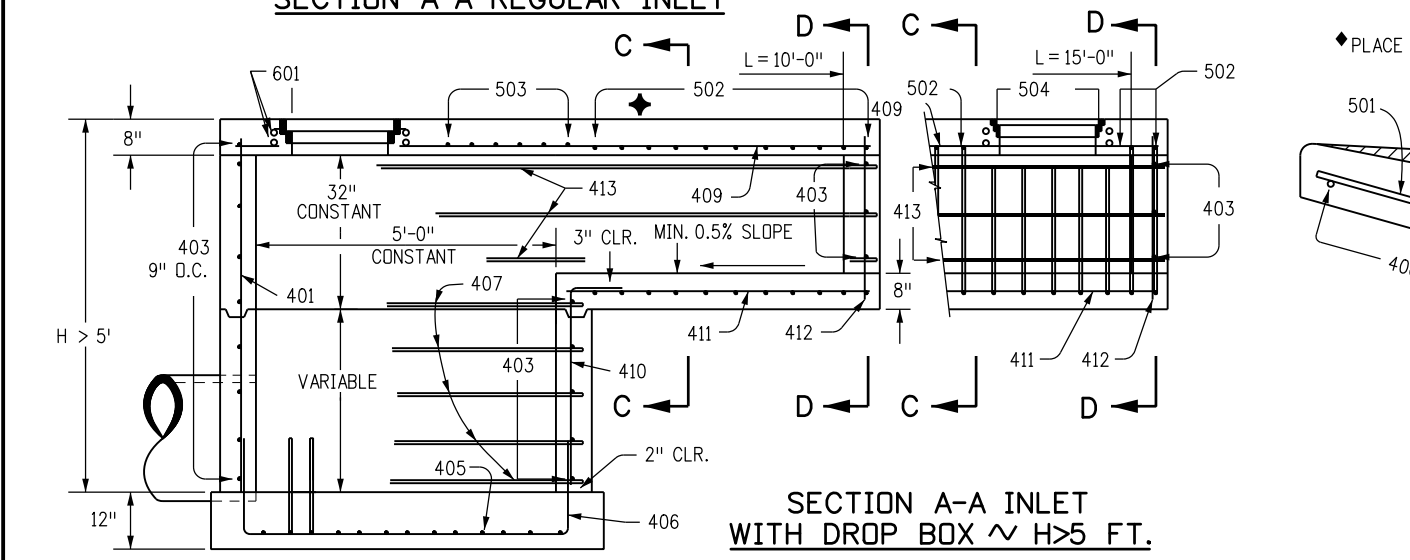

SECTION A-A INLET  
WITH DROP BOX ~ H > 5 FT.

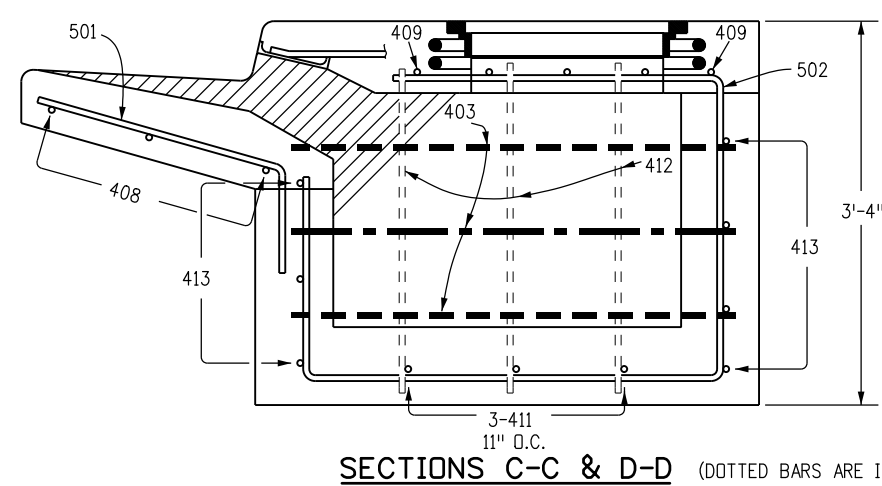

SECTIONS C-C & D-D (DOTTED BARS ARE IN SECTION D-D)

Computer File Information	
Creation Date:	07/31/19
Designer Initials:	JBK
Last Modification Date:	07/31/19
Detailer Initials:	LTA
CAD Ver.:	MicroStation V8
Scale:	Not to Scale
Units:	English

Sheet Revisions	
Date:	Comments
(R-X)	
(R-X)	
(R-X)	
(R-X)	

Colorado Department of Transportation  
2829 West Howard Place  
CDOT HQ, 3rd Floor  
Denver, CO 80204  
Phone: 303-757-9021 FAX: 303-757-9868

**Project Development Branch**      **JBK**

# CURB INLET TYPE R

Issued by the Project Development Branch: July 31, 2019

**STANDARD PLAN NO.**  
**M-604-12**  
**Standard Sheet No. 1 of 2**

Project Sheet Number:

MARK	BAR # OR SIZE	O.C. SPACING	TYPE	ALL INLETS		INLETS: H ≤ 5 FT.				INLETS: H > 5 FT.										
				L = 5 FT.		L = 10 FT.		L = 15 FT.		L = 10 FT.		L = 15 FT.								
				NO. REQ'D.	LENGTH	NO. REQ'D.	LENGTH	NO. REQ'D.	LENGTH	NO. REQ'D.	LENGTH	NO. REQ'D.	LENGTH							
401	4	11"	II	15	*	21	*	26	*	11	*	11	*							
402	4	11"	II	7	*	13	*	18	*	7	*	7	*							
403	4	9"	II	*	4'-0"	*	4'-0"	*	4'-0"	*	4'-0"	*	4'-0"							
405	4	6"	VI	11	6'-10"	21	6'-10"	31	6'-10"	11	6'-10"	11	6'-10"							
406	4	6"	VIII	7	8'-10"	7	13'-10"	7	18'-10"	7	8'-10"	7	8'-10"							
407	4	9"	II	*	5'-10"	*	10'-10"	*	15'-10"	*	5'-10"	*	5'-10"							
408	4	12"	II	3	6'-10"	3	11'-10"	3	16'-0"	3	11'-10"	3	16'-0"							
409	4	8"	II	6	5'-10"	6	10'-10"	6	15'-10"	6	10'-10"	6	15'-10"							
410	4	11"	VII							3		3	*							
411	4	11"	II							3	5'-2"	3	10'-2"							
412	4	11"	II							3	2'-9"	3	2'-9"							
413	4	9"	II							7	10'-10"	7	15'-10"							
501	5	5 1/2"	IV	11	3'-4"	22	3'-4"	33	3'-4"	22	3'-4"	33	3'-4"							
502	5	5 1/2"	III							11	11'-5"	17	11'-5"							
503	5	5 1/2"	II	5	3'-6"	16	3'-6"	27	3'-6"	6	3'-6"	6	3'-6"							
504	5	5 1/2"	IX									5	8'-4"							
601	6	2 1/2"	V	2	8'-10"	2	8'-10"	2	8'-10"	2	8'-10"	4	8'-10"							
8(E.5)				1	5'-10"	1	10'-10"	1	15'-10"	1	10'-10"	1	15'-10"							
				2 BARS, 1 RODS	4 BARS, 3 RODS				8 BARS, 5 RODS				4 BARS, 3 RODS				8 BARS, 5 RODS			

\* VARIABLE REFER TO TABLE TWO.  
 ■ INCLUDE #4, 18 IN. BARS (SEE CHANNEL LAYOUT).

**TABLE ONE ~ BAR LIST FOR CURB INLETS, TYPE "R"**

"H"	LENGTH			NO. REQ'D.		NO. REQ'D.		L = 5 FT.		L = 10 FT.		L = 15 FT.	
	401	402	410	REGULAR		DROP BOX		CONC. CU. YDS.	STEEL LBS.	CONC. CU. YDS.	STEEL LBS.	CONC. CU. YDS.	STEEL LBS.
	403	407	403	407									
3'-0"	2'-8"	1'-8"		10	7			3.2	285	5.3	497	7.4	706
3'-6"	3'-2"	2'-2"		10	7			3.4	305	5.7	528	7.9	747
4'-0"	3'-8"	2'-8"		12	9			3.7	326	6.0	559	8.4	786
4'-6"	4'-2"	3'-2"		12	9			3.9	334	6.4	571	8.8	803
5'-0"	4'-8"	3'-8"		14	11			4.1	354	6.7	602	9.3	844
5'-6"	5'-2"	4'-2"	3'-5"	16	13	15	6	4.4	375	6.0	607	7.4	850
6'-0"	5'-8"	4'-8"	3'-11"	16	13	16	6	4.6	382	6.2	616	7.6	860
6'-6"	6'-2"	5'-2"	4'-5"	18	15	18	8	4.8	402	6.4	637	7.8	880
7'-0"	6'-8"	5'-8"	4'-11"	20	17	19	10	5.0	423	6.6	654	8.0	897
7'-6"	7'-2"	6'-2"	5'-5"	20	17	20	10	5.3	430	6.9	664	8.3	907
8'-0"	7'-8"	6'-8"	5'-11"	22	19	22	12	5.5	451	7.1	684	8.5	927
8'-6"	8'-2"	7'-2"	6'-5"	24	21	23	14	5.7	471	7.3	702	8.7	944
9'-0"	8'-8"	7'-8"	6'-11"	24	21	24	14	6.0	479	7.6	711	9.0	954
9'-6"	9'-2"	8'-2"	7'-5"	26	23	26	16	6.2	499	7.8	732	9.2	974
10'-0"	9'-8"	8'-8"	7'-11"	28	25	27	18	6.4	520	8.0	749	9.4	992
10'-6"	10'-2"	9'-2"	8'-5"	28	25	28	18	6.7	527	8.3	759	9.7	1001
11'-0"	10'-8"	9'-8"	8'-11"	30	27	30	20	6.9	547	8.5	779	9.9	1022

NOTES: FOR L=5 FT., L=10 FT., AND L=15 FT.  
 REGULAR INLETS: TOTAL QUANTITIES NEEDED ARE OUTSIDE THE HEAVY BLACK LINE.  
 DROP BOX INLETS: TOTAL QUANTITIES NEEDED ARE INSIDE THE HEAVY BLACK LINE.  
 STEEL WEIGHTS DO NOT INCLUDE STRUCTURAL STEEL CHANNEL.

**TABLE TWO ~ BARS AND QUANTITIES VARIABLE WITH "H"**

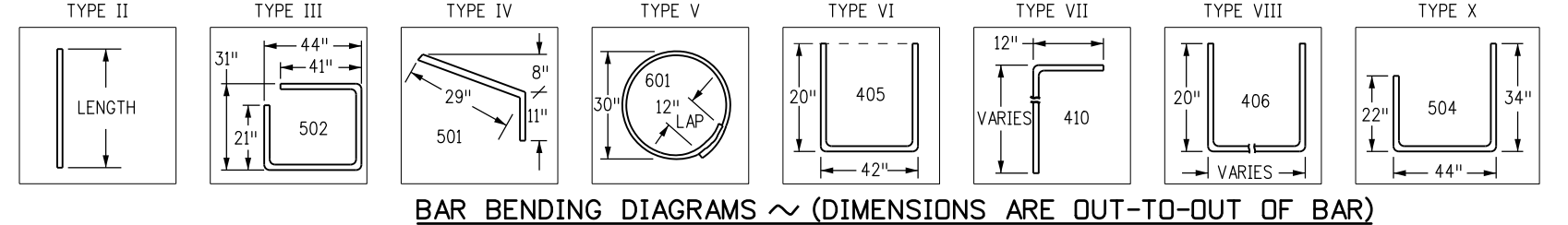
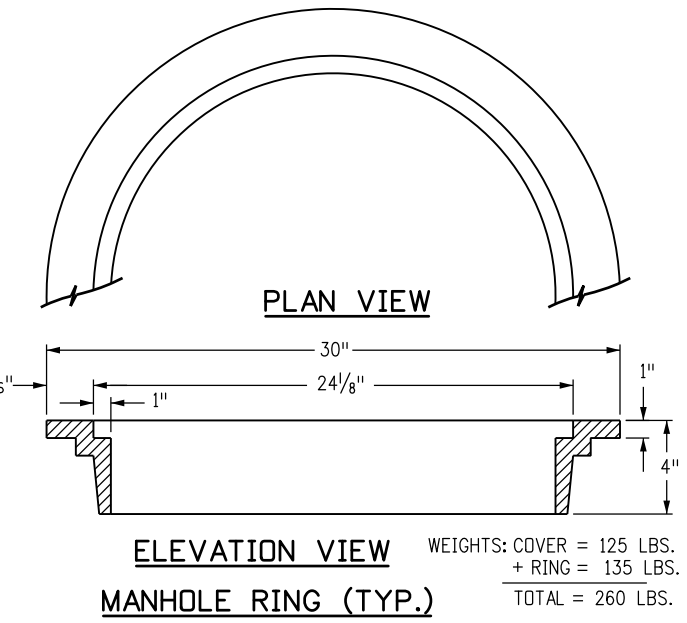
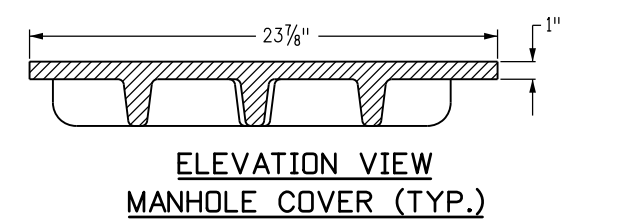
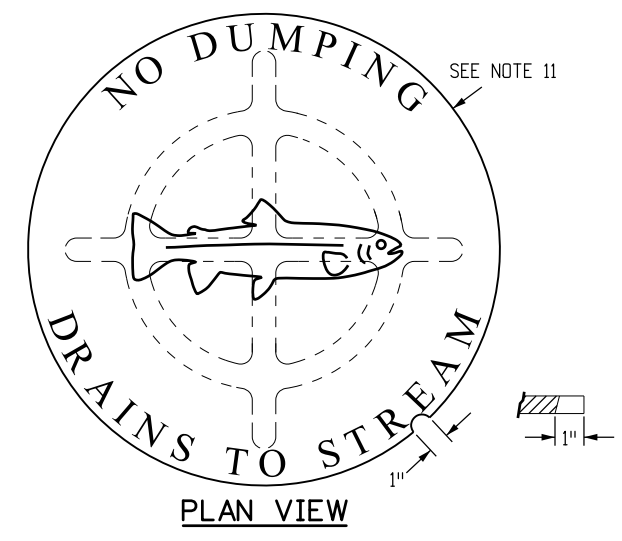

- GENERAL NOTES**
- CONCRETE SHALL BE CLASS B. INLET MAY BE CAST-IN-PLACE OR PRECAST.
  - CONCRETE WALLS SHALL BE FORMED ON BOTH SIDES AND SHALL BE 8 INCHES THICK.
  - INLET STEPS SHALL BE IN CONFORMANCE WITH AASHTO M 199.
  - CURB FACE ASSEMBLY SHALL BE GALVANIZED AFTER WELDING.
  - EXPOSED CONCRETE CORNERS SHALL BE CHAMFERED 3/4 OF AN INCH. CURB AND GUTTER CORNERS SHALL BE FINISHED TO MATCH THE EXISTING CURB AND GUTTER BEYOND THE TRANSITION GUTTER.
  - REINFORCING BARS SHALL BE DEFORMED AND SHALL HAVE A 2 INCH MINIMUM CLEARANCE. ALL REINFORCING BARS SHALL BE GRADE 60 AND EPOXY COATED.
  - DIMENSIONS AND WEIGHTS OF TYPICAL MANHOLE RING AND COVER ARE NOMINAL.
  - MATERIAL FOR MANHOLE RINGS AND COVERS SHALL BE GRAY OR DUCTILE CAST IRON IN ACCORDANCE WITH SUBSECTION 712.06.
  - SINCE PIPE ENTRIES INTO THE INLET ARE VARIABLE, THE DIMENSIONS SHOWN ARE TYPICAL. ACTUAL DIMENSIONS AND QUANTITIES FOR CONCRETE AND REINFORCEMENT SHALL BE AS REQUIRED IN THE WORK. QUANTITIES INCLUDE VOLUMES OCCUPIED BY PIPES.
  - STRUCTURAL STEEL SHALL BE GALVANIZED AND SHALL BE IN ACCORDANCE WITH SUBSECTION 712.06.
  - ALL MANHOLE COVERS SHALL BE CAST WITH A "NO DUMPING DRAINS TO STREAM" MESSAGE AND A FISH SYMBOL. THE SURFACE OF THE MANHOLE COVER SHALL HAVE A NON-SLIP PATTERN.

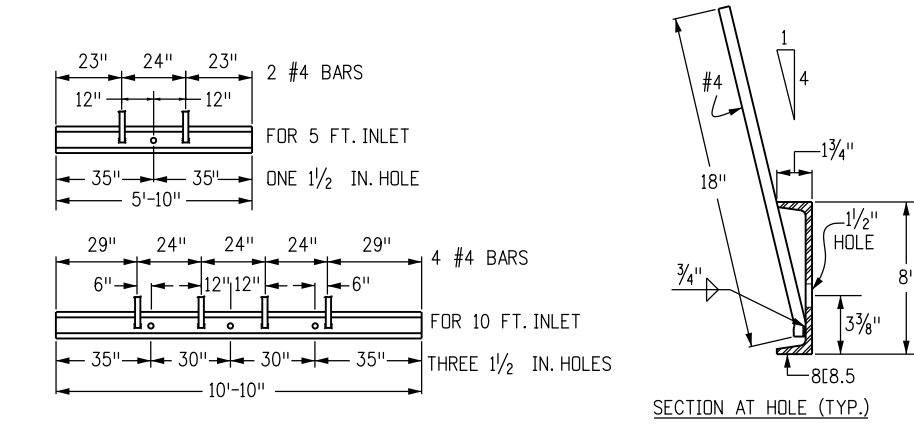

**Computer File Information**

Creation Date: 07/31/19
Designer Initials: JBK
Last Modification Date: 07/31/19
Detailer Initials: LTA
CAD Ver.: MicroStation V8 Scale: Not to Scale Units: English

**Sheet Revisions**

Date:	Comments:
(R-X)	
(R-X)	
(R-X)	
(R-X)	

Colorado Department of Transportation

2829 West Howard Place  
 CDDT HQ, 3rd Floor  
 Denver, CO 80204  
 Phone: 303-757-9021 FAX: 303-757-9868

**Project Development Branch** **JBK**

**CURB INLET  
TYPE R**

Issued by the Project Development Branch: July 31, 2019

**STANDARD PLAN NO.  
M-604-12**

**Standard Sheet No. 2 of 2**

Project Sheet Number: