

CURB AND GUTTER TYPE 2
(SECTION IB)
(6 IN. BARRIER - 1 FT. GUTTER)

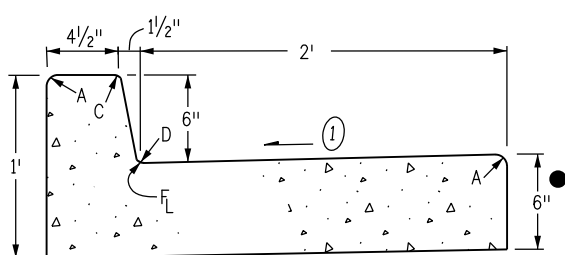

CURB AND GUTTER TYPE 2
(SECTION IIB)
(6 IN. BARRIER - 2 FT. GUTTER)

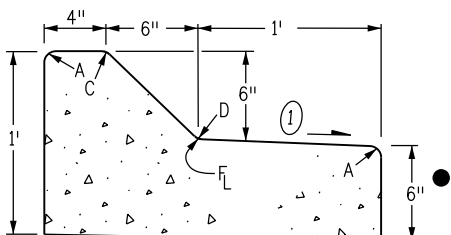

CURB AND GUTTER TYPE 2
(SECTION IM)
(6 IN. MOUNTABLE - 1 FT. GUTTER)

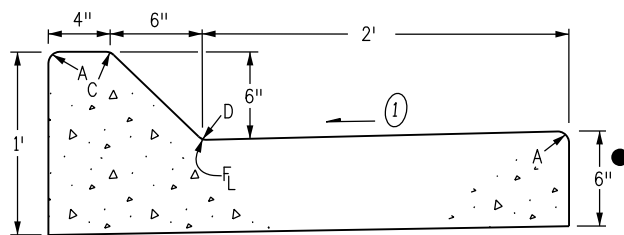

CURB AND GUTTER TYPE 2
(SECTION IIM)
(6 IN. MOUNTABLE - 2 FT. GUTTER)

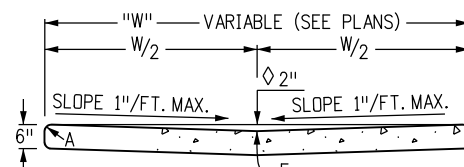

2 IN. DEPTH WHEN USED AS A
CROSSSPAN IN AN INTERSECTION

GUTTER TYPE 2

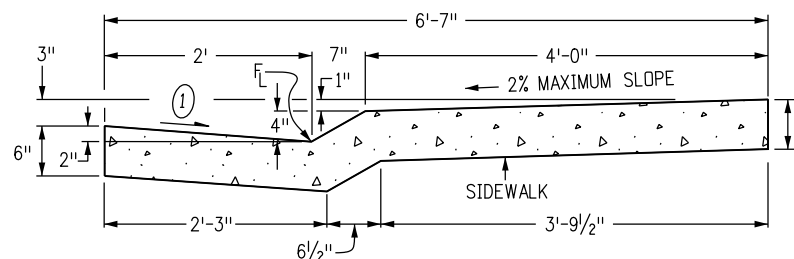

CURB AND GUTTER TYPE 2
(SECTION MS)
(4 IN. MOUNTABLE WITH SIDEWALK)

LEGEND FOR RADII	
A	= 1/8" TO 1/4"
B	= 1"
C	= 1 1/2"
D	= 1 1/2" TO 2"

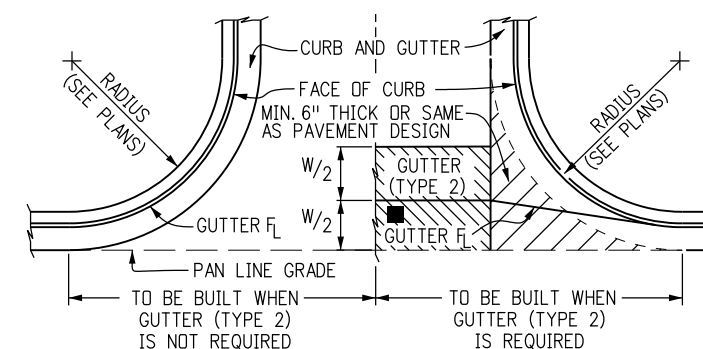

THIS AREA SHALL BE POURED MONOLITHICALLY WITH CURB AND GUTTER AND PAID FOR AS "CONCRETE PAVEMENT".

FLOW LINE LOCATION WILL BE ESTABLISHED BY W/2 SHOWN ON PLANS.

CONSTRUCTION OF CONCRETE GUTTERS AT INTERSECTION

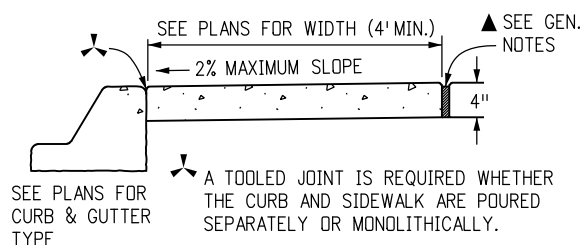

CONCRETE SIDEWALK

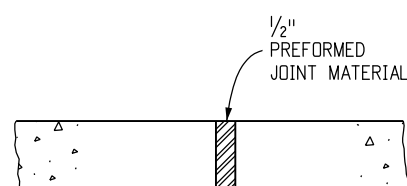

NOTES: 1. EXPANSION JOINTS SHALL BE PLACED IN THE SIDEWALK AT INTERVALS OF NOT MORE THAN 500 FT.

2. EXPANSION JOINTS MAY BE SEALED WHEN SPECIFIED ON THE PLANS.

SIDEWALK EXPANSION JOINT

- GENERAL NOTES**
- ON ROADWAY CURVES WITH A RADIUS OF 1,900 FT. OR LESS, CURBS AND GUTTERS ARE TO BE PLACED ON THE ARC OF THE CURVE, UNLESS OTHERWISE NOTED ON THE PLANS. A MAXIMUM CHORD LENGTH OF 10 FT. MAY BE USED WHEN THE CURVE RADIUS IS GREATER THAN 1,900 FT.
 - CONCRETE SHALL BE CLASS B.
 - PROFILE GRADE OF CURBS AND GUTTERS SHALL BE LOCATED AT THE FLOW LINE.
 - CURB TYPE 4 (KEY-WAY) MAY BE USED IN LIEU OF CURB AND GUTTER TYPE 2 (SECTIONS IB AND IM) UNLESS OTHERWISE SPECIFIED ON THE PLANS.
 - GUTTER CROSS SLOPES MAY BE ADJUSTED TO FACILITATE DRAINAGE FOR PROFILE GRADES AS SHOWN ON THE PLANS.
 - THICKNESS OF CURB AND GUTTER SECTION SHALL MATCH CONCRETE PAVEMENT THICKNESS IF SHOWN ON THE PLANS. CURB AND GUTTER SHALL BE CLASS P CONCRETE IF PLACED MONOLITHICALLY WITH CONCRETE PAVEMENT.
 - INCREASE SIDEWALK THICKNESS TO 6 IN. AT LOCATIONS SHOWN ON THE PLANS.
 - MINIMUM SIDEWALK WIDTH IS 4 FT.

▲ EXPANSION JOINTS SHALL BE INSTALLED WHEN ABUTTING EXISTING CONCRETE OR FIXED STRUCTURE. EXPANSION JOINT MATERIAL SHALL BE 1/2 IN. THICK AND SHALL EXTEND THE FULL DEPTH OF CONTACT SURFACE.

① GUTTER CROSS SLOPES SHALL BE 1/2 IN./FT. WHEN DRAINING AWAY FROM CURB AND 1 IN./FT. WHEN DRAINING TOWARD CURB (WITH EXCEPTION TO IMMEDIATELY ADJACENT TO CURB RAMPS - SEE STANDARD PLAN M-608-1 FOR SLOPE REQUIREMENTS).

● WHEN TIE BARS ARE REQUIRED, THE GUTTER THICKNESS SHALL BE INCREASED TO THE PAVEMENT THICKNESS (T). BARS SHALL BE EPOXY-COATED #4 CONFORMING TO AASHTO M 284 AND SPACED AT 3 FT. INTERVALS. THEY SHALL BE INSERTED T/2 AND 1#2 LENGTH INTO THE GUTTER.

Computer File Information

Creation Date: 07/31/19	(R-X)
Designer Initials: JBK	(R-X)
Last Modification Date: 07/31/19	(R-X)
Detailer Initials: LTA	(R-X)
CAD Ver.: MicroStation V8 Scale: Not to Scale Units: English	(R-X)

Sheet Revisions

Date:	Comments

Colorado Department of Transportation
2829 West Howard Place
CDDT HQ, 3rd Floor
Denver, CO 80204
Phone: 303-757-9021 FAX: 303-757-9868
Project Development Branch JBK

CURB, GUTTERS, AND SIDEWALKS

Issued by the Project Development Branch: July 31, 2019

STANDARD PLAN NO.

M-609-1

Standard Sheet No. 1 of 4

Project Sheet Number:

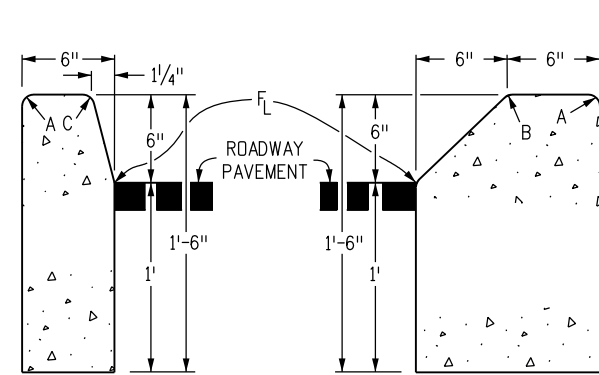

CURB TYPE 2
(SECTION B)
6 IN. BARRIER

CURB TYPE 2
(SECTION M)
6 IN. MOUNTABLE

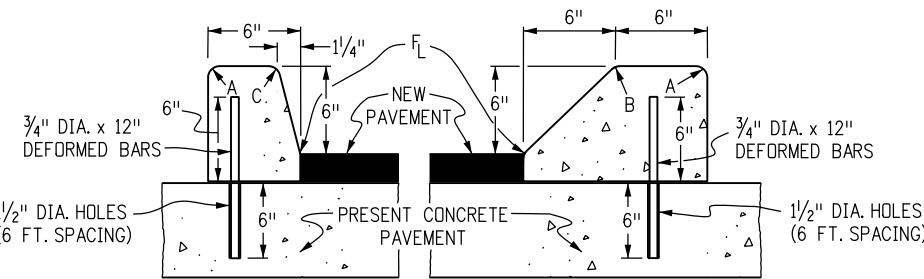

CURB TYPE 4
(SECTION B)
6 IN. BARRIER

CURB TYPE 4
(SECTION M)
6 IN. MOUNTABLE

3/4" DIA. x 12" DEFORMED REINFORCING BARS AT 6 FT. SPACING SHALL BE GROUTED IN 1/4" DIA. HOLES IN EXISTING CONCRETE. GROUT SHALL CONSIST OF 2 PARTS CLEAN SAND AND 1 PART CEMENT. COST OF INSTALLATION SHALL BE INCLUDED IN THE PRICE BID FOR CURB.

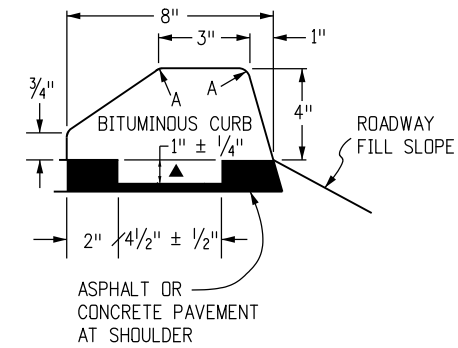

CURB TYPE 6
(SECTION M)
4 IN. MOUNTABLE

NOTE: BITUMINOUS OR CONCRETE* UNLESS OTHERWISE SPECIFIED ON THE PLANS.

▲ KEY-WAY MAY BE OMITTED WHEN PLACED UNDER GUARDRAIL.

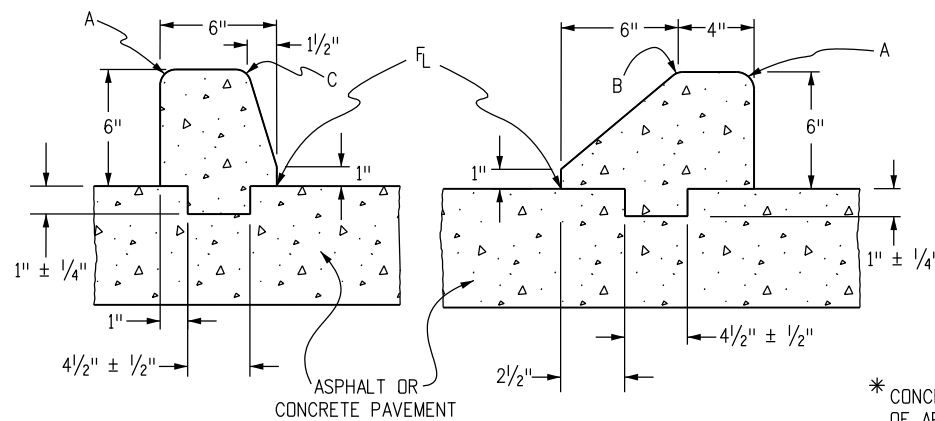

(SECTION B)

(SECTION M)

CURB TYPE 4 (KEY-WAY)*

* CONCRETE CLASS B SHALL CONTAIN 1.5 POUNDS PER CUBIC YARD OF APPROVED POLYPROPYLENE FIBERS AND MAY HAVE A NOMINAL AGGREGATE SIZE OF 3/8 IN.

LEGEND FOR RADII	
A	= 1/8 TO 1/4"
B	= 1"
C	= 1 1/2"
D	= 1 1/2" TO 2"

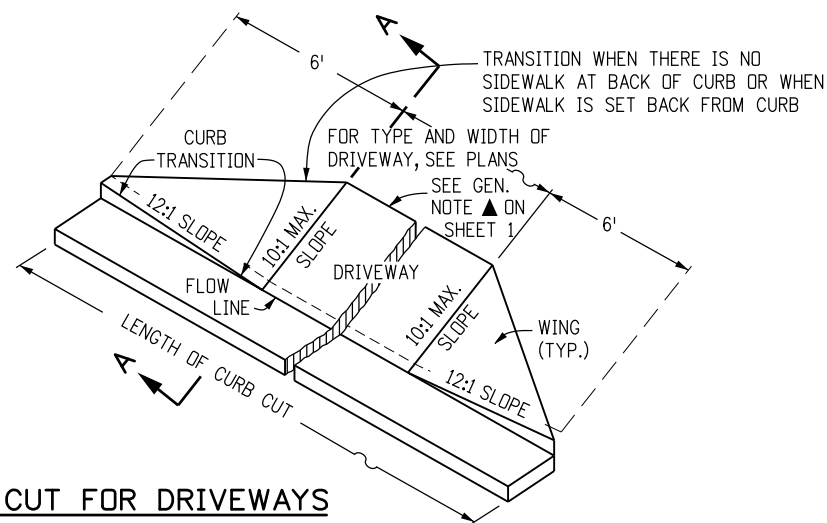

CURB CUT FOR DRIVEWAYS
(WITHOUT ATTACHED SIDEWALK)

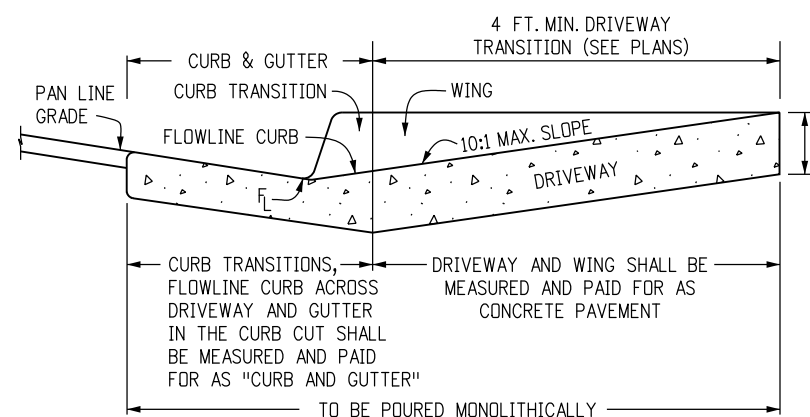

SECTION A-A

CONCRETE PAVEMENT (DRIVEWAYS)

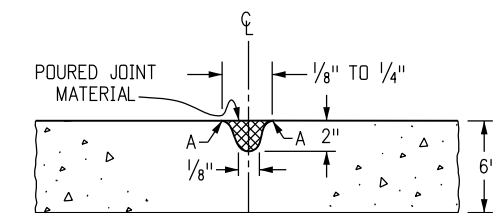

NOTE: RECOMMENDED JOINT SPACING IS EVERY 8 FOOT ALONG THE WIDTH AND LENGTH OF DRIVEWAY. FOR DRIVEWAYS WIDER THAN 12 FEET, JOINTS ARE REQUIRED.

TRANSVERSE CONTRACTION JOINT FOR CONCRETE PAVEMENT (DRIVEWAYS)

Computer File Information

Creation Date: 07/31/19	(R-X)
Designer Initials: JBK	(R-X)
Last Modification Date: 07/31/19	(R-X)
Detailer Initials: LTA	(R-X)
CAD Ver.: MicroStation V8 Scale: Not to Scale Units: English	(R-X)

Sheet Revisions

Date:	Comments

Colorado Department of Transportation
2829 West Howard Place
CDDT HQ, 3rd Floor
Denver, CO 80204
Phone: 303-757-9021 FAX: 303-757-9868
Project Development Branch JBK

CURB, GUTTERS, AND SIDEWALKS

Issued by the Project Development Branch: July 31, 2019

STANDARD PLAN NO.

M-609-1

Standard Sheet No. 2 of 4

Project Sheet Number:

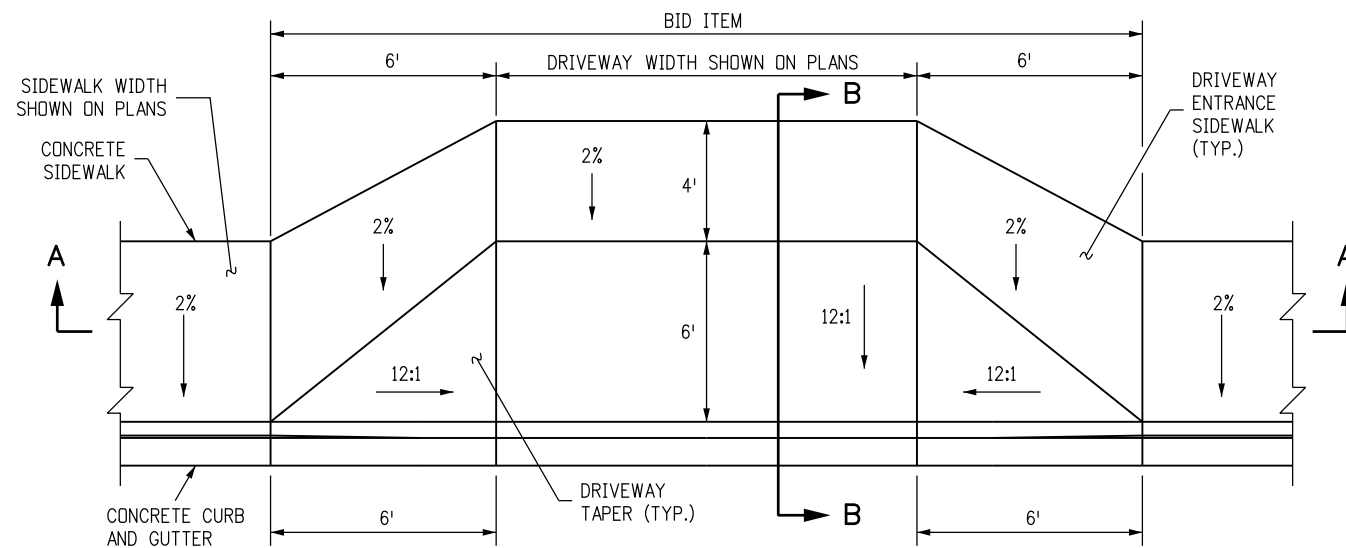

CONCRETE DRIVEWAY ENTRANCE TYPE 1

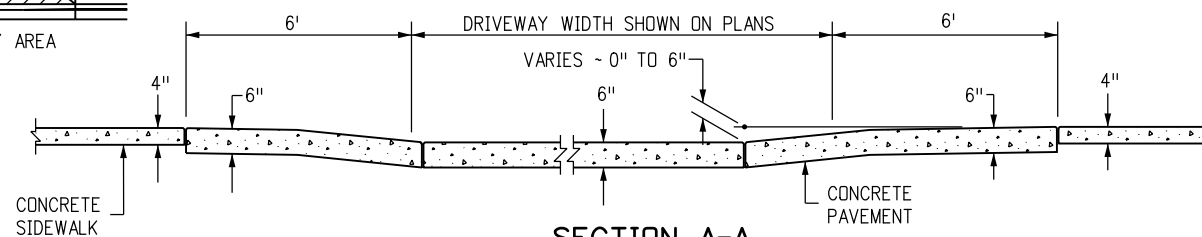
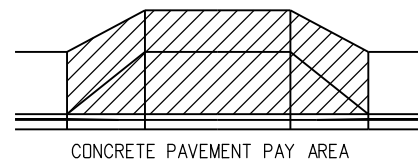

SECTION A-A

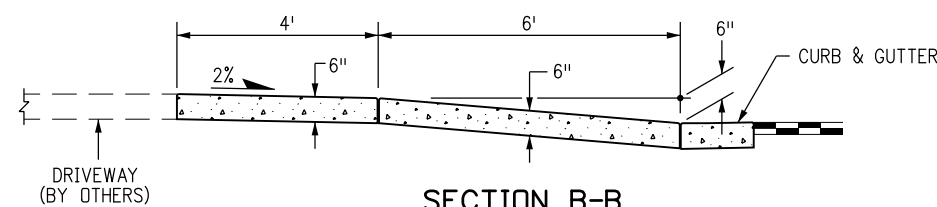

SECTION B-B

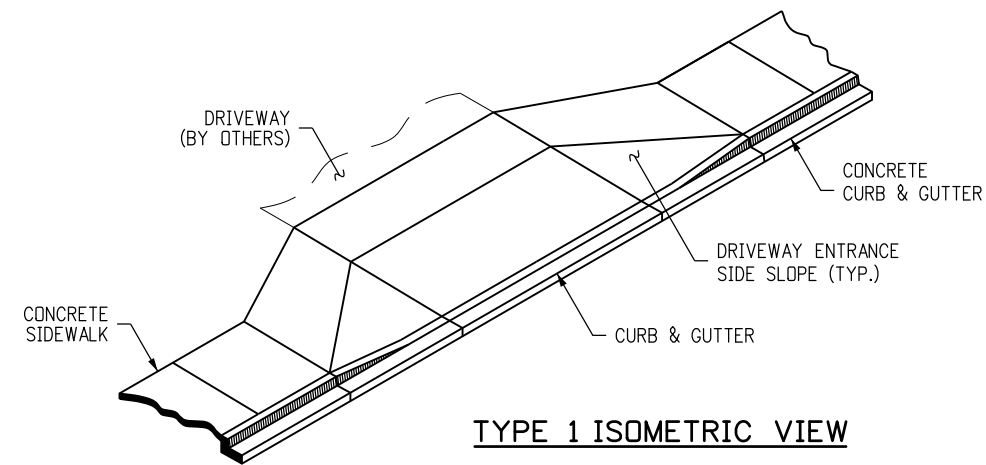

TYPE 1 ISOMETRIC VIEW

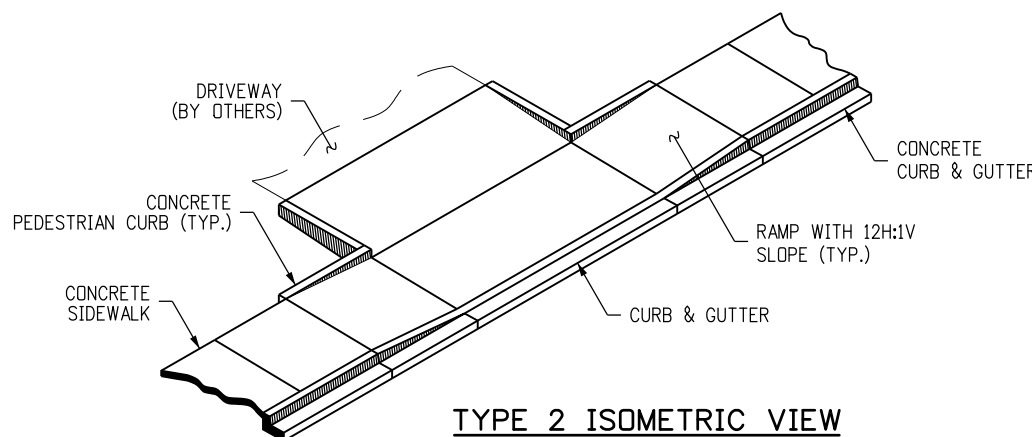

TYPE 2 ISOMETRIC VIEW

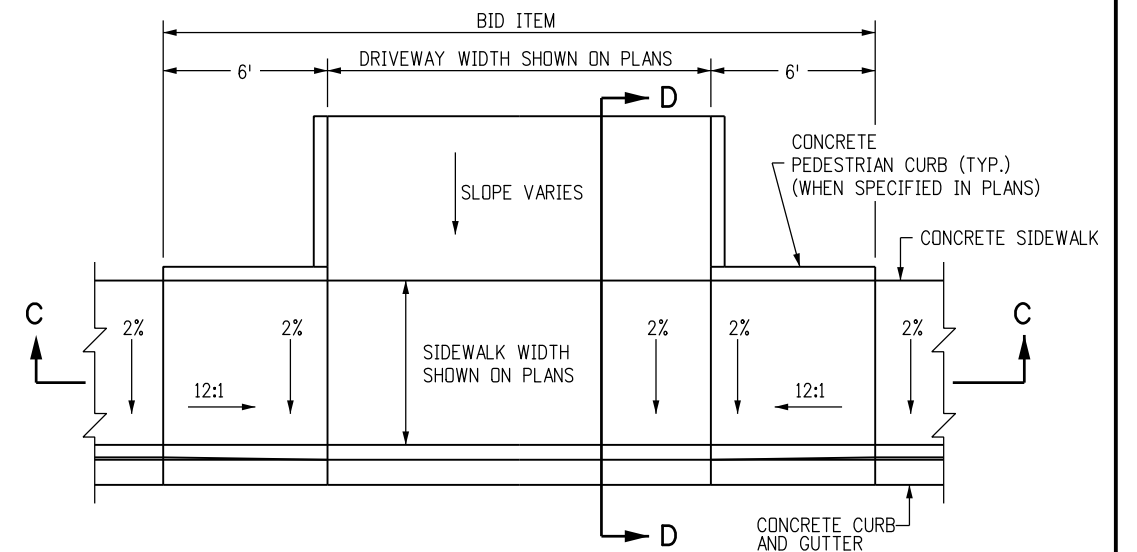

CONCRETE DRIVEWAY ENTRANCE TYPE 2

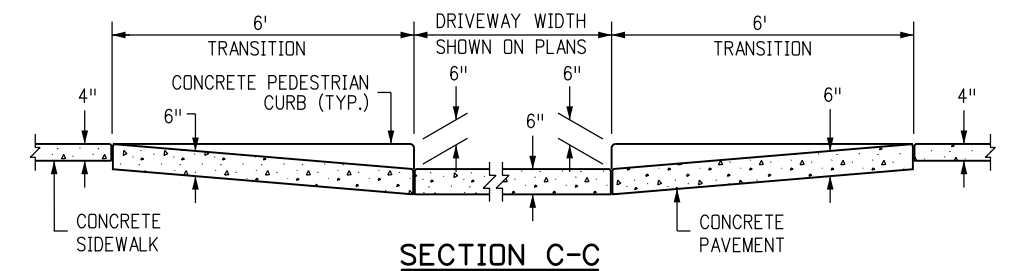
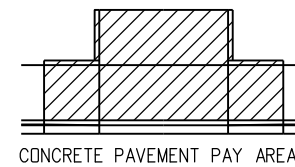

SECTION C-C

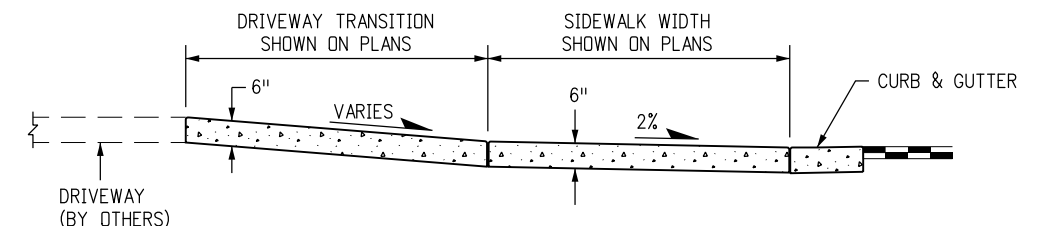

SECTION D-D

NOTES

1. DRAINAGE STRUCTURES, TRAFFIC SIGNAL EQUIPMENT, JUNCTION BOXES, AND OTHER OBSTRUCTIONS SHOULD NOT BE PLACED IN FRONT OF THE DRIVEWAY RAMP ACCESS AREAS.
2. FOR THE CURB AND GUTTER SHOWN, SEE PLANS FOR CURB TYPE.
3. RAMP SLOPES SHALL BE 12:1 OR FLATTER.
4. CONSTRUCTION OF THE CONCRETE PEDESTRIAN CURB SHALL BE INCLUDED IN THE BID PRICE OF THE CONCRETE PAVEMENT.

Computer File Information

Creation Date: 07/31/19
Designer Initials: JBK
Last Modification Date: 07/31/19
Detailer Initials: LTA
CAD Ver.: MicroStation V8 Scale: Not to Scale Units: English

Sheet Revisions

Date:	Comments
(R-X)	
(R-X)	
(R-X)	
(R-X)	

Colorado Department of Transportation
 2829 West Howard Place
 CDDT HQ, 3rd Floor
 Denver, CO 80204
 Phone: 303-757-9021 FAX: 303-757-9868
 Project Development Branch JBK

CURB, GUTTERS, AND SIDEWALKS

Issued by the Project Development Branch: July 31, 2019

STANDARD PLAN NO.

M-609-1

Standard Sheet No. 3 of 4

Project Sheet Number:

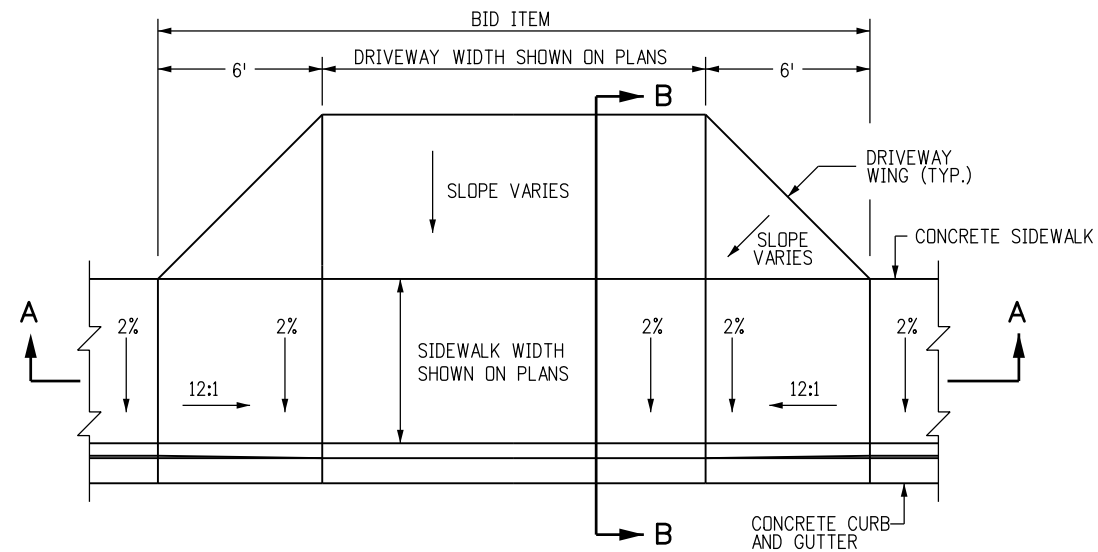

CONCRETE DRIVEWAY ENTRANCE TYPE 3

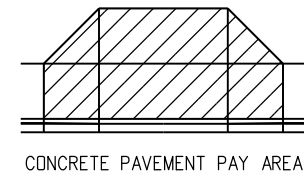
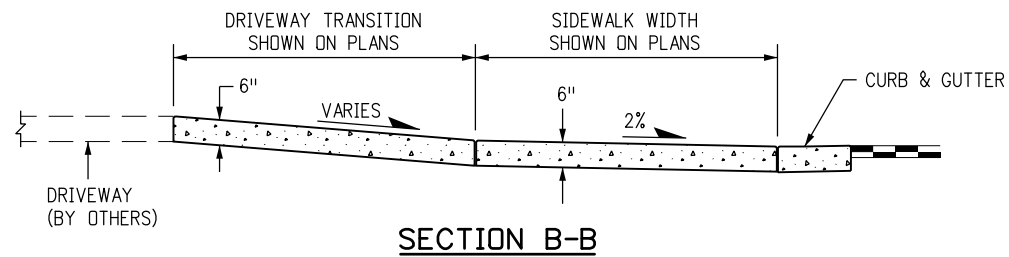
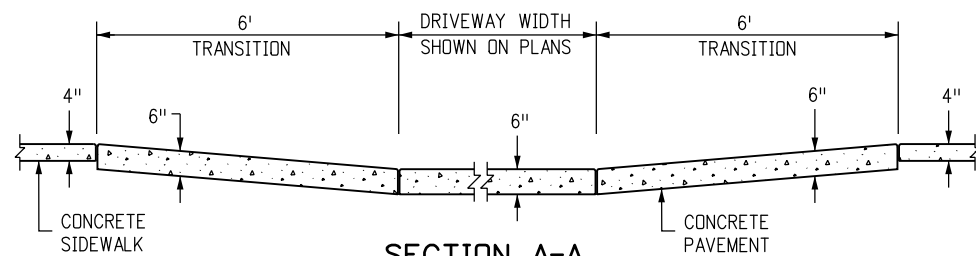

NOTES

1. DRAINAGE STRUCTURES, TRAFFIC SIGNAL EQUIPMENT, JUNCTION BOXES, AND OTHER OBSTRUCTIONS SHOULD NOT BE PLACED IN FRONT OF THE DRIVEWAY RAMP ACCESS AREAS.
2. FOR THE CURB AND GUTTER SHOWN, SEE PLANS FOR CURB TYPE.
3. RAMP SLOPES SHALL BE 12:1 OR FLATTER.

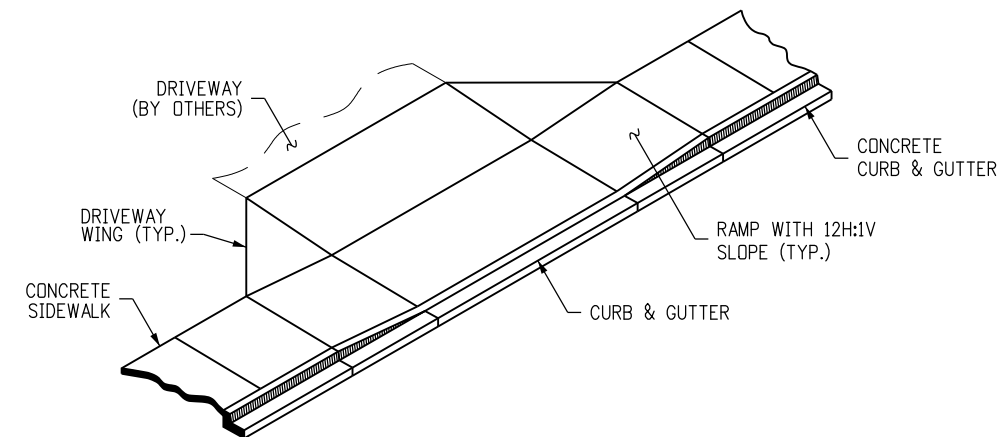

TYPE 3 ISOMETRIC VIEW

Computer File Information	
Creation Date: 07/31/19	
Designer Initials: JBK	(R-X)
Last Modification Date: 07/31/19	(R-X)
Detailer Initials: LTA	(R-X)
CAD Ver.: MicroStation V8 Scale: Not to Scale Units: English	(R-X)

Sheet Revisions	
Date:	Comments

Colorado Department of Transportation
 2829 West Howard Place
 CDDT HQ, 3rd Floor
 Denver, CO 80204
 Phone: 303-757-9021 FAX: 303-757-9868



Project Development Branch JBK

**CURB, GUTTERS,
AND SIDEWALKS**

Issued by the Project Development Branch: July 31, 2019

STANDARD PLAN NO. M-609-1
Standard Sheet No. 4 of 4
Project Sheet Number: