

GENERAL NOTES

1. FRAME CONNECTIONS * (A1) (A2)

- A. SILL AND FRAME ASSEMBLY CONNECTIONS SHALL BE MADE WITH 5/8 IN. DIA. MACHINE BOLTS (A 307) WITH A MINIMUM OF 1/4 IN. USABLE THREAD LENGTH. NYLON INSERT LOCKNUTS SHALL BE PROVIDED WITH EACH BOLT. BOLT LENGTHS INDICATED HEREIN ARE BASED ON THE MOST TYPICAL WOOD THICKNESS ENCOUNTERED. BECAUSE OF THE VARIANCE OF ROUGH SAWN WOOD THICKNESS, IT MAY BE NECESSARY TO PROVIDE BOLTS OF DIFFERENT LENGTHS, ADDITIONAL WASHERS, OR BOTH TO MEET THE FOLLOWING REQUIREMENTS.
- B. BOLTED CONNECTIONS SHALL BE TIGHTENED TO A CLAMP TIGHT CONDITION. DO NOT CRUSH WOOD FIBERS BY OVER TIGHTENING CONNECTIONS. AFTER THE CONNECTIONS ARE TIGHTENED, THE LOCKOUT SHALL BE COMPLETELY THREADED ON THE BOLT WITH A MINIMUM OF ONE THREAD PROTRUDING BEYOND THE NUT, AND A MAXIMUM OF 1/2 IN. OF THE THREAD PROTRUDING BEYOND THE NUT. ADDITIONAL WASHERS MAY BE REQUIRED TO SHIM THE CONNECTION SO THAT NO MORE THAN 1/2 IN. OF THREAD PROTRUDES. THIS REQUIREMENT PROVIDES A MINIMUM OF 1/4 IN. OF THREAD REMAINING FOR FURTHER TIGHTENING AS THE WOOD CONTINUES TO WEATHER.

2. SLAT FASTENING (B)

SLATS SHALL BE ATTACHED TO EACH FRONT VERTICAL FRAME WITH 2-10D RING SHANK OR SCREW SHANK NAILS (FULL HEAD). THE USE OF NAILING GUNS IS ACCEPTABLE.

3. CROSS BRACE AND SLOPE BRACE FASTENING (C)

- A. CROSS BRACES SHALL BE FASTENED TO SLATS WITH 2-8D COMMON NAILS AT EACH LOCATION AND SHALL BE CLINCHED.
- B. SLOPE BRACES ARE REQUIRED IF THE GROUND SLOPE IS 5:1 OR STEEPER. WHEN THE SLOPE BRACE IS REQUIRED, IT SHALL BE ATTACHED IN THE SAME MANNER AS THE CROSS BRACE.

4. ANCHORS ▲ (D)

- A. THE ENDS OF EACH SILL SHALL BE ANCHORED WITH A DRIVEN #6 REBAR CLAMPED TO THE SILL WITH AN ANCHOR CLIP AS SHOWN IN THE DETAILS ON SHEET 2.
- B. WHERE REBARS CANNOT BE DRIVEN AS SPECIFIED DUE TO ROCK CONDITIONS, REBAR SHALL BE ANCHORED IN THE ROCK. A 7/8 IN. DIA. HOLE SHALL BE DRILLED A MINIMUM OF 6 IN. INTO SOLID ROCK AND ALL LOOSE MATERIAL AND DUST REMOVED. THE REBAR SHALL BE INSTALLED WITH AN APPROVED EPOXY GROUT IN CONFORMANCE WITH THE MANUFACTURER'S RECOMMENDATIONS.
- C. THE ROCK ANCHOR SHALL BE FASTENED TO THE FRAME AS SHOWN IN THE PLANS EXCEPT THAT THE ANCHOR MAY BE PERPENDICULAR TO THE SILL. IF NO ANCHORS CAN BE DRIVEN, FOUR ROCK ANCHORS, TWO FOR EACH OUTER SILL, SHALL BE INSTALLED PER PANEL.
- D. SOIL REMOVED PRIOR TO DRILLING SHALL BE REPLACED AND COMPACTED.

5. LINE POSTS (9)

- A. TWO LINE POSTS SHALL BE PLACED AT THE ENDS OF EACH RUN OF SNOW FENCE AS SHOWN.
- ▲ SEE ANCHOR CLIP CONNECTION DETAILS ON SHEET 2.
- * SEE FRAME CONNECTION DETAIL ON SHEET 2.

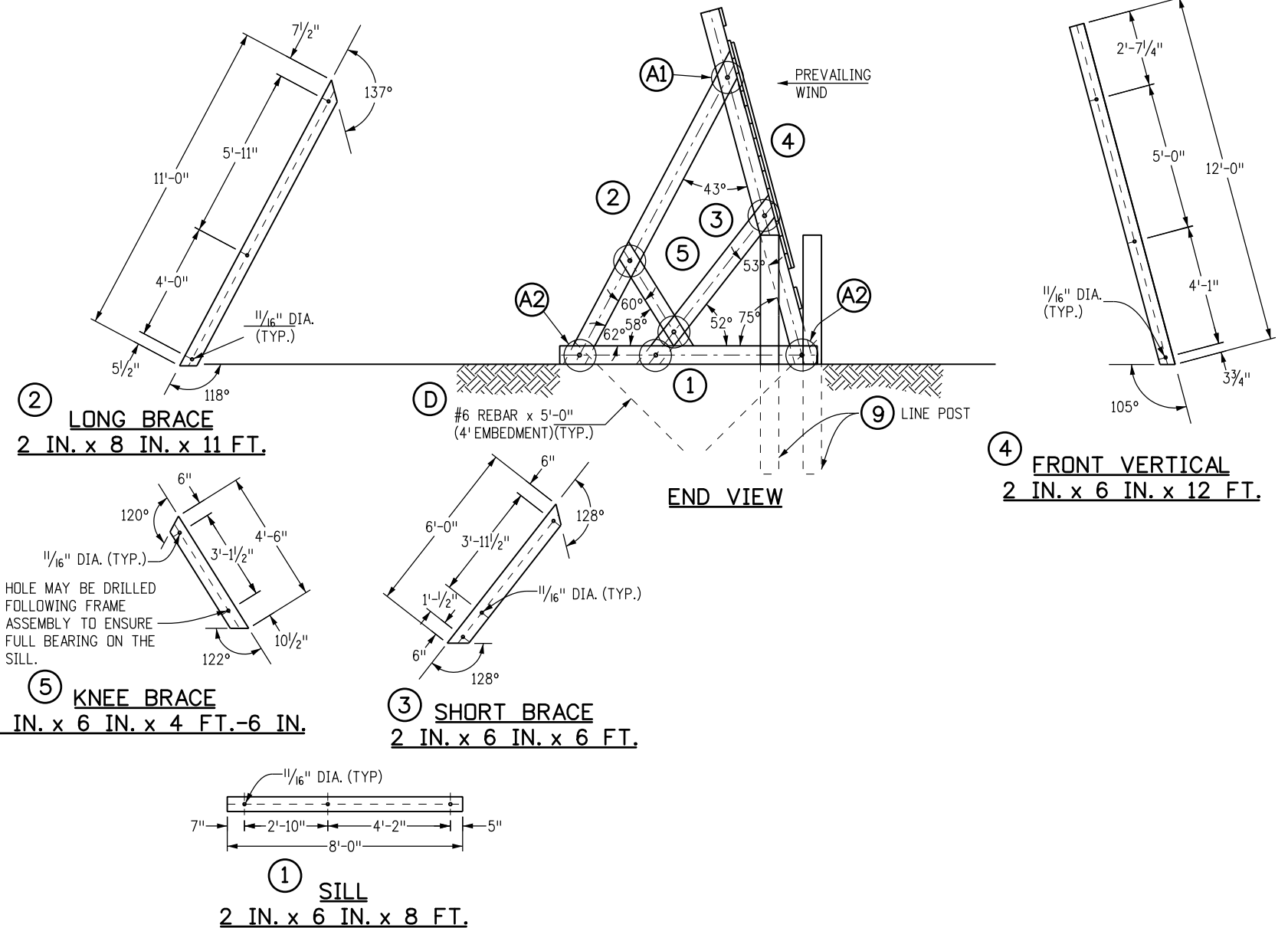
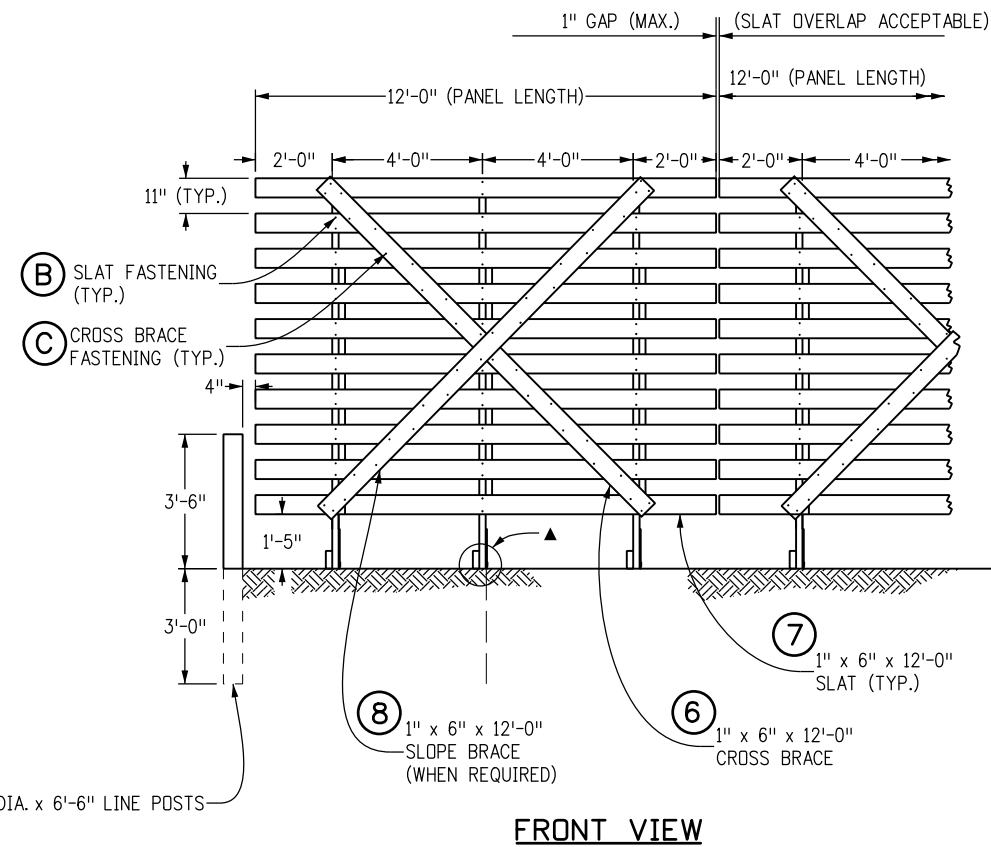

Computer File Information		Sheet Revisions		Colorado Department of Transportation		As Constructed		WOOD SNOW FENCE 12 FOOT HIGH		Project No./Code	
Creation Date: 07/31/19		(R-X)	mm/dd/yy	XXXXXXX	XXXXXX	Street Address		No Revisions: mm/dd/yy		XXXXX/XXXX	
Designer Initials: JBK		(R-X)	mm/dd/yy	XXXXXXX	XXXXXX	Office location		Revised: mm/dd/yy		D-607-12	
Last Modification Date: 07/31/19		(R-X)	mm/dd/yy	XXXXXXX	XXXXXX	City, CO Zip code		Sheet Number: 1 of 2		Sheet Number: 1 of 2	
Detailer Initials: LTA		(R-X)	mm/dd/yy	XXXXXXX	XXXXXX	Phone: XXX-XXX-XXXX Fax: XXX-XXX-XXXX		Detailer: XXXXXXXX		Project Sheet Number: XX	
CAD Ver.: MicroStation V8 Scale: Not to Scale Units: English		(R-X)	mm/dd/yy	XXXXXXX	XXXXXX	Region, Unit		Void: mm/dd/yy		Sheet Subset: XXXXXXXX Subset Sheets: XXX of XXX	

LUMBER FOR ONE 12 FT. WIDE PANEL

ITEM NO.	NO. OF PIECES	LUMBER SIZE	DESCRIPTION
1	3	2" x 6" x 8'-0"	SILL
2	3	2" x 8" x 11'-0"	LONG BRACE
3	3	2" x 6" x 6'-0"	SHORT BRACE
4	3	2" x 6" x 12'-0"	FRONT VERTICAL
5	3	2" x 6" x 4'-6"	KNEE BRACE
9	▲ 4	6" DIA. (MIN.) x 6'-6"	LINE POST
▽ FRAME MEMBERS 1, 2, 3, 4, 5 AND 9 SHALL BE PRESSURE TREATED LUMBER IN ACCORDANCE WITH SUBSECTION 710.08 (AASHTO M133).			
6	1	1" x 6" x 12'-0"	CROSS BRACE
7	12	1" x 6" x 12'-0"	SLAT
8	1	1" x 6" x 12'-0"	SLOPE BRACE

NOTE: SLOPE BRACE (8) IS REQUIRED WHEN GROUND SLOPE IS 5:1 OR STEEPER

▲ NOTE: TWO LINE POSTS SHALL BE PLACED AT THE ENDS OF EACH RUN OF SNOW FENCE.

▽ USE ALKALINE COPPER (ACQ) OR COPPER AZOLE (CBA) FOR THE PRESSURE TREATED PORTIONS OF THE FENCE UNLESS CHROMATED COPPER ARSENATE (CCA) IS APPROVED BY THE ENGINEER.

HARDWARE FOR ONE 12 FT. WIDE PANEL

NOTE	QUANTITY	DESCRIPTION
A2	∅ 6	5/8" DIA. x 6" MACHINE BOLT WITH 1 OR MORE FLAT WASHERS (MIN.) AND 1 NYLON INSERT LOCKOUT
A1	∅ 15	5/8" DIA. x 5" MACHINE BOLT WITH 2 OR MORE FLAT WASHERS (MIN.) AND 1 NYLON INSERT LOCKOUT
B	72	10D RING SHANK OR SCREW SHANK NAILS (FULL HEAD) WITH 2 OR MORE FLAT WASHERS
C	* 22	8D COMMON NAILS
D	6	#6 x 5'-0" REBAR
	6	5" x 1 1/2" x 1/8" ANCHOR CLIP FOR 5/8" DIA. BOLT

* 44 IF SLOPE BRACE IS USED

(B) SLAT FASTENING

∅ ADDITIONAL WASHERS SHOULD BE ANTICIPATED. SEE BOLTING DETAIL.

(C) CROSS BRACE AND SLOPE BRACE FASTENING

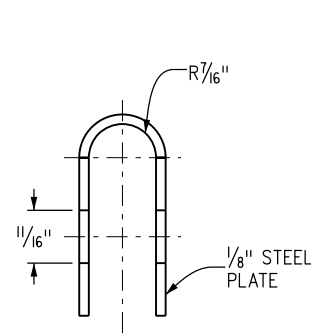

END VIEW OF ANCHOR CLIP

(AFTER BENDING)

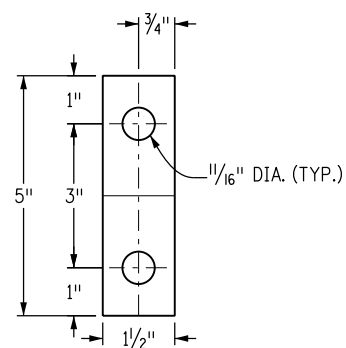

ANCHOR CLIP FOR 5/8 IN. DIA. BOLT

NOTE: (FLAT PLATE PRIOR TO BENDING) HOLES SHALL BE NO GREATER THAN 1/16 IN. LARGER THAN THE BOLT.

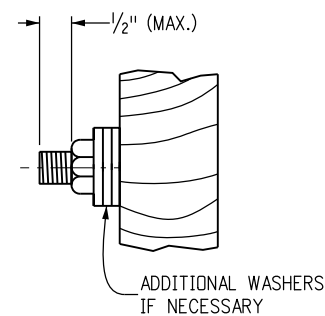
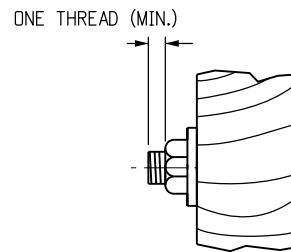

BOLTING DETAIL

A MINIMUM OF 1/4 IN. OF THREAD SHALL REMAIN FOR FURTHER TIGHTENING.

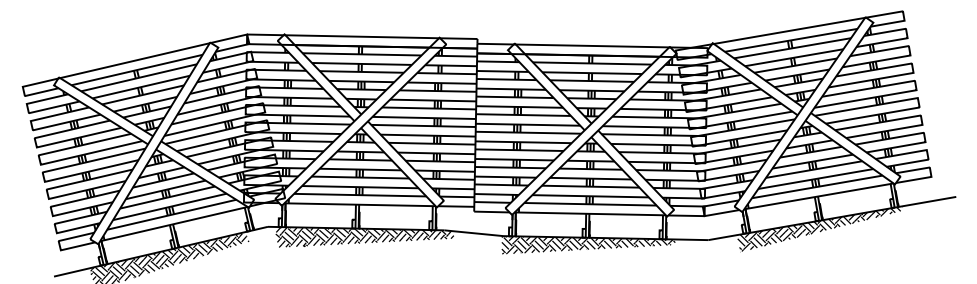

PANEL LAPPING DETAIL

NOTE: PANELS SHALL BE OVERLAPPED. A MAXIMUM 1 IN. GAP IS ACCEPTABLE. SEE FRONT VIEW ON SHEET 1.

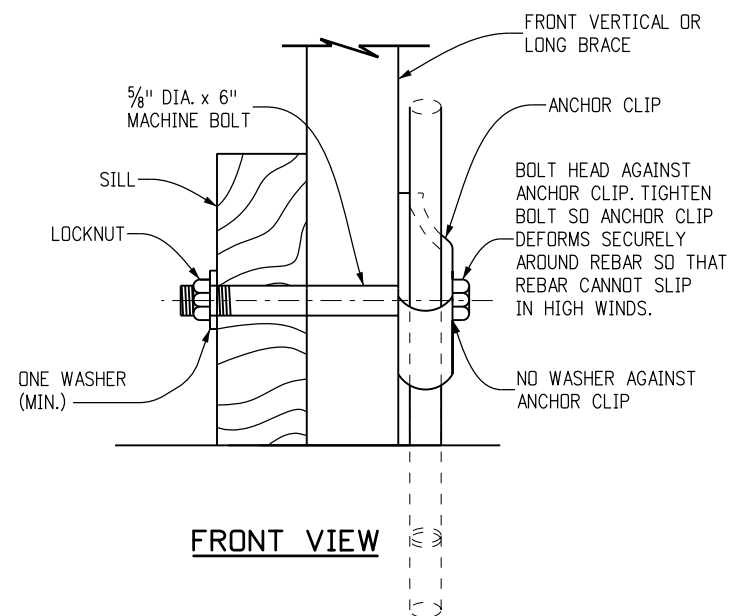

FRONT VIEW

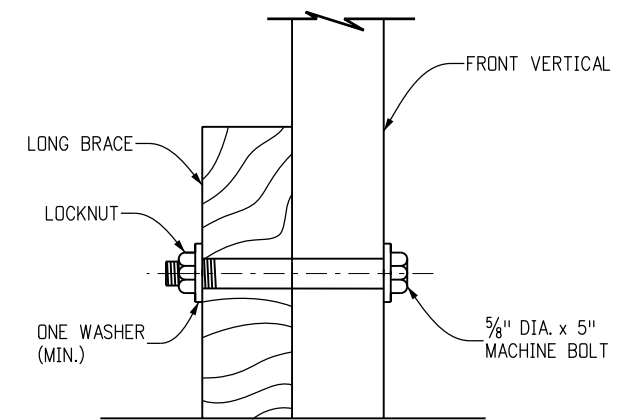

FRONT VIEW

(A1) FRAME CONNECTION DETAIL

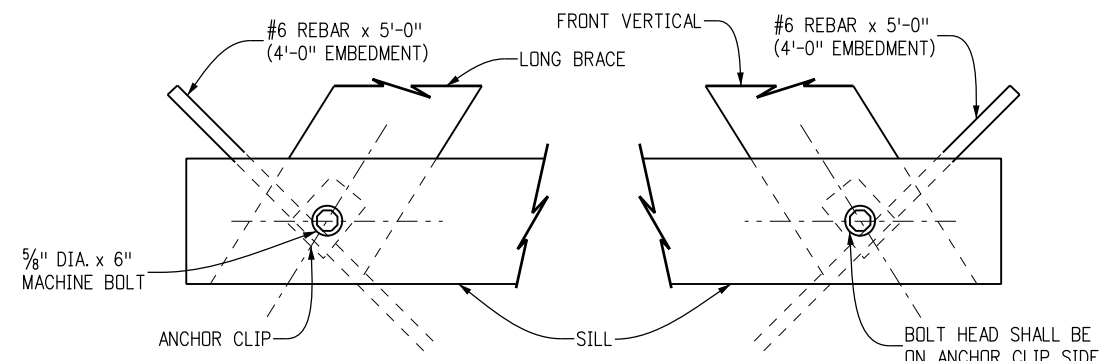

END VIEW

END VIEW

(A2) ANCHOR CLIP CONNECTION DETAILS

Computer File Information	Sheet Revisions	Colorado Department of Transportation	As Constructed	WOOD SNOW FENCE 12 FOOT HIGH	Project No./Code
Creation Date: 07/31/19	(R-X) mm/dd/yy XXXXXXXX XXXXXX	Street Address	No Revisions: mm/dd/yy	Designer: XXXXXXXX	XXXXX/XXXX
Designer Initials: JBK	(R-X) mm/dd/yy XXXXXXXX XXXXXX	Office location	Revised: mm/dd/yy		D-607-12
Last Modification Date: 07/31/19	(R-X) mm/dd/yy XXXXXXXX XXXXXX	City, CO Zip code	Void: mm/dd/yy	Detailer: XXXXXXXX	Sheet Number: 2 of 2
Detailer Initials: LTA	(R-X) mm/dd/yy XXXXXXXX XXXXXX	Phone: XXX-XXX-XXXX Fax: XXX-XXX-XXXX		Sheet Subset: XXXXXXXX	Project Sheet Number: XX
CAD Ver.: MicroStation V8 Scale: Not to Scale Units: English	(R-X) mm/dd/yy XXXXXXXX XXXXXX	Region, Unit		Subset Sheets: XXX of XXX	