



## Chapter 12 Accessible Pedestrian Design

- 12.1 Introduction ..... 1
  - 12.1.1 CDOT’s ADA Transition Plan ..... 3
  - 12.1.2 List of Definitions ..... 3
- 12.2 ADA Accessibility Requirements, Standards, and Guidelines ..... 5
  - 12.2.1 New Construction Project Requirements..... 5
  - 12.2.2 Alteration Project Requirements PROWAG (R202 & R203) ..... 6
  - 12.2.3 Alterations - PROWAG (R202) ..... 6
    - Figure 12-1 Maintenance vs. Alteration for Surface Treatment Projects ..... 7*
  - 12.2.4 Alterations to Qualified Historic Facilities - PROWAG (R202.3.4) Non-Alteration Project Requirements ..... 7
  - 12.2.5 Technically Infeasible ..... 8
  - 12.2.6 Unaltered Existing Facilities & the ADA Transition Plan ..... 9
- 12.3 Technical Requirements for Accessibility..... 9
  - 12.3.1 Pedestrian Access Route Technical Requirements - PROWAG (R302)..... 9
    - 12.3.1.1 Continuous Width PROWAG (R302.3)..... 10
      - Figure 12-2 Passing Spaces ..... 10*
    - 12.3.1.2 Pinch Points ..... 10
      - Figure 12-3 Pinch Point ..... 11*
    - 12.3.1.3 Surface - PROWAG (R302.7) ..... 11
      - Figure 12-4 Allowable Vertical Discontinuities ..... 11*
    - 12.3.1.4 PAR Vertical Alignment - PROWAG (R302.7.1)..... 12
    - 12.3.1.5 Openings and Horizontal Gaps - PROWAG (R302.7.3) ..... 12
      - Figure 12-5 Horizontal Openings in Grates ..... 12*
    - 12.3.1.6 Flangeway Gaps - PROWAG (R302.7.4) ..... 12
      - Figure 12-6 Flangeway Gaps at Pedestrian At-Grade Rail Crossings ..... 13*
    - 12.3.1.7 Protruding Objects - PROWAG (R402)..... 13
    - 12.3.1.8 Shared-Use Path Protruding Objects - PROWAG (R210.3) ..... 13
      - Figure 12-7 Protruding Objects..... 13*
    - 12.3.1.9 Reduced Vertical Clearance - PROWAG (R402.4) ..... 13
      - Figure 12-8 Protection from Stairways..... 14*
    - 12.3.1.10 Post Mounted Objects PROWAG (R402.3) ..... 14
      - Figure 12-9 Post-Mounted Objects ..... 14*
    - 12.3.1.11 Grade - PROWAG (R302.5 through 302.5.5)..... 14
    - 12.3.1.12 Cross Slope - PROWAG (R302.6)..... 14



*Figure 12-10 Pedestrian Street Crossing Cross Slope* ..... 15

12.4 Curb Ramp General Information ..... 16

*Figure 12-11 Curb Ramp Elements* ..... 16

*Figure 12-12 Preferred Curb Ramp Placement*..... 17

12.5 Curb Ramp Types ..... 18

*Figure 12-13 Perpendicular Curb Ramp Examples*..... 18

*Figure 12-14 Parallel Curb Ramp Example*..... 18

*Figure 12-15 Blended Transition/Depressed Corner Example* ..... 19

12.6 Curb Ramp Technical Requirements..... 19

    12.6.1 Curb Ramp Running Slope - PROWAG (R304.2.2, R304.3.2 & R304.4.1)..... 19

    12.6.2 Curb Ramp Cross Slope - PROWAG (R304.5.3)..... 19

    12.6.3 Curb Ramp Width - PROWAG (R304.5.1) ..... 20

    12.6.4 Grade Breaks - PROWAG (R304.5.2)..... 20

*Figure 12-16 Curb Ramp Grade Breaks* ..... 20

    12.6.5 Curb Ramp Turning Spaces - PROWAG (R304.2.1 & R304.3.1) ..... 20

*Figure 12-17 Transitioning Steep Roadway Slopes* ..... 21

*Figure 12-18 Street Grade at Curb Ramps Examples*..... 21

    12.6.6 Curb Ramp Clear Spaces - PROWAG (R304.5.5) ..... 22

*Figure 12-19 Perpendicular Curb Ramp Clear Spaces* ..... 22

    12.6.7 Flared Sides - PROWAG (R304.2.3) ..... 22

*Figure 12-20 Flared Sides*..... 23

    12.6.8 Counter Slope - PROWAG (R304.5.4)..... 23

*Figure 12-21 Curb Ramp Counter Slope Requirements* ..... 23

12.7 Detectable Warning Surfaces - PROWAG (R305) ..... 24

    12.7.1 Placement..... 24

        12.7.1.1 Pedestrian Street Crossings - PROWAG (R208.1 & R305.2) ..... 24

        12.7.1.2 Parallel Curb Ramps - PROWAG (R305.2.2) ..... 25

*Figure 12-22 Parallel Curb Ramp DWS Placement* ..... 25

        12.7.1.3 Perpendicular Ramps - PROWAG (R305.2.1) ..... 25

*Figure 12-23 Perpendicular Curb Ramp DWS Placement* ..... 26

        12.7.1.4 Pedestrian Refuge Islands - PROWAG (R305.2.4)..... 26

*Figure 12-24 Pedestrian Refuge DWS Placement* ..... 27

        12.7.1.5 Pedestrian At-Grade Rail Crossings - PROWAG (R305.2.5)..... 27

12.8 Pedestrian Push Buttons ..... 27









*Figure 12-25 Pedestrian Push Button Reach Ranges*..... 28

*Figure 12-26 Pedestrian Push Button Placement* ..... 29



12.9 Pedestrian Ramp, Landings & Handrails - PROWAG (R407 “RAMPS”)..... 29  
*Figure 12-27 Pedestrian Ramp Elements*..... 30  
*Figure 12-28 Pedestrian Ramp Turning Space Requirements*..... 30

**Legend**

	Multimodal Application Example
	Context-Sensitive Solutions Application Example
	Performance-Based Practical Design Application Example
	Multimodal (MM)
	Context-Sensitive Solutions (CSS)
	Performance-Based Practical Design (PBPD)
	Web link for additional information
	AASHTO-Specific Information

# Chapter 12



## 12 Accessible Pedestrian Design

### 12.1 Introduction

Pedestrians may be present in all roadway environments and facility types. Pedestrian access, accommodation, and safety should be given full consideration during all project planning, scoping, and design. Accommodation can take many forms but most often appears as sidewalks or shared-use paths. In rural areas or on roadways with limited pedestrian demand, paved shoulders and sometimes no facility at all may be an acceptable level of pedestrian accommodation. Sidewalks are not a requirement on every roadway; however, if there is evidence that pedestrian demand exists or will exist in the future, suitable pedestrian facilities shall be provided.

CDOT's Civil Rights & Business Resource Center's website for CDOT's Accessibility Program has Quick Links to the Program's resources, including a page with Americans with Disabilities Act (ADA) Resources for Engineers," which illustrates how CDOT's Accessibility program implements the requirements of the ADA on its projects through CDOT's ADA standards, guidelines, and policies.



Use this link for information about CDOT's Accessibility Program:  
<https://www.codot.gov/business/civilrights/ada>

The Americans with Disabilities Act of 1990 was the nation's first comprehensive civil rights law that prohibits discrimination against people with disabilities. Under Title II of the ADA and Section 504 of the Rehabilitation Act of 1973 (504), entities that are responsible for roadway and pedestrian facilities may not discriminate on the basis of disability in any transportation program, activity, service, or benefit which is provided to the general public. In other words, entities responsible for transportation infrastructure must ensure that people with disabilities have equitable opportunities to use the infrastructure that is provided to the public. The ADA

accessibility requirements apply throughout the entire transportation facility lifecycle including planning, design, construction, maintenance, and operation.

Where pedestrian facilities are provided, they must be constructed so they are accessible to all potential users. This chapter provides guidance and direction regarding the requirements for the design of accessible pedestrian facilities. There are many supplemental resources that can help with pedestrian accommodations. Links to those resources are provided throughout this chapter.

Under the ADA, the U.S. Department of Transportation (USDOT) and the U.S. Department of Justice (USDOJ) are responsible for issuing and enforcing accessibility standards. The standards are developed by the U.S. Access Board, which is an independent agency that promotes equality for people with disabilities and is the leading source of information on accessible design. The U.S. Access Board's guidelines become enforceable once they are adopted by the respective standard setting agency, which in the case of CDOT are the Americans with Disabilities Act (ADA) Standards for Transportation Facilities adopted by the USDOT (USDOT, 2006). Both USDOJ's latest ADA Standards and the USDOT's 2006 ADA Standards are very similar and are closely based on the U.S. Access Board's ADA Accessibility Guidelines (ADAAG) (U.S. Access Board, 2002). However, each contain a few unique provisions. One very important difference for CDOT is the requirement of Detectable Warnings on curb ramps.

To ensure that people with disabilities have access to the built environment, the U.S. Access Board developed design guidelines known as the ADA Accessibility Guidelines (ADAAG) (U.S. Access Board, 2002). However, pedestrian infrastructure in the public right of way can pose many challenges to accessibility, and the ADAAG was developed with a focus on providing accessible buildings and facilities.

Although the ADAAG does address some features found within the public right of way, it was determined that additional guidance was necessary to address conditions and constraints that are unique to public rights of way. The additional guidance developed was titled the Proposed Rule Public Rights of Way Accessibility Guidelines (PROWAG) (U.S. Access Board, 2011). These draft guidelines are not standards until adopted by the USDOJ and the USDOT. However, in 2006, USDOT adopted the 2004 ADAAG as accessibility standards under Section 504, but in doing so, USDOT added Section 406.8, which requires detectable warnings at curb ramps.



*Use this link to read FHWA's 2006 Questions and Answers About ADA/Section 504:*  
[https://www.fhwa.dot.gov/civilrights/programs/ada/ada\\_sect504qa.cfm](https://www.fhwa.dot.gov/civilrights/programs/ada/ada_sect504qa.cfm)

---

Both the ADAAG and the PROWAG provide the means to meet the requirements of the ADA. Generally, facilities located within the public right of way shall be consistent with the requirements set forth in the PROWAG. Once the PROWAG is adopted by the USDOJ and the USDOT, it will become the enforceable standard for transportation facilities under Title II of the ADA.

Throughout this chapter, there are specific PROWAG scoping and technical references in parenthesis next to the subject/title with additional CDOT-specific language, if applicable. (i.e., PROWAG R200).



Use this link for information on the ADAAG and PROWAG: <https://www.access-board.gov/ada>

---

### 12.1.1 CDOT's ADA Transition Plan

CDOT's *ADA Transition Plan* describes how the various departments within CDOT are implementing ADA requirements for facilities owned by CDOT. It also describes CDOT's policies and standards related to PROWAG, including CDOT's definition of PROWAG functional accessibility related to curb ramps.



Use this link to access CDOT's ADA Transition Plan: <https://www.codot.gov/business/civilrights/ada/transition-plan>

---

### 12.1.2 List of Definitions

- **Accessible.** Describes a facility in the public right of way that complies with the requirements set forth in the ADAAG or the PROWAG.
- **ADA.** Americans with Disabilities Act.
- **ADA Transition Plan.** The 1991 ADA regulation (28 CFR Part 35) required all public entities to evaluate all their services, policies, and practices and to modify any that did not meet ADA requirements. Public entities with 50 or more employees were required to develop a transition plan detailing any structural changes that would be undertaken to achieve program access and specify a period for their completion.
- **ADAAG.** An acronym for ADA Accessibility Guidelines.
- **Accessible Pedestrian Signal (APS).** A traffic signal that incorporates a device to communicate information to a pedestrian in audible and vibrotactile formats.
- **Alteration.** A change to a facility in the public right of way that affects or could affect the usability of that facility. Alterations include, but are not limited to, resurfacing, rehabilitation, reconstruction, historic restoration, or changes or rearrangement of structural parts or elements of a facility.
- **Blended Transition.** A raised pedestrian street crossing, depressed corner, or similar connection between the pedestrian access route at the level of the sidewalk and the pedestrian street crossing.
- **Cross Slope.** The grade that is perpendicular to the dominant direction of pedestrian travel.





- **Curb Ramp.** A combination of a ramp and landing to accomplish a change in elevation at a curb face. This element provides street and sidewalk access to pedestrians using a mobility device, such as a wheelchair, a walker, or crutches.
- **Detectable Warning Surface (DWS).** A standardized surface feature of truncated domes that provides an indication to individuals with disabilities that they are transitioning from the pedestrian realm to the vehicular way.
- **Equivalent Facilitation.** The use of alternative designs, products, or technologies that result in substantially equivalent or greater accessibility and usability than the requirements in the PROWAG and/or ADAAG.
- **Facility.** All or any portion of buildings, structures, improvements, elements, and pedestrian or vehicular routes located in the public right of way.
- **Grade Break.** The line where two surface planes with different grades meet.
- **Landing/Landing Space.** The area of the Pedestrian Access Route at the top or bottom of a curb ramp. Refer to Turning Space definition below for requirements.
- **Maximum Extent Feasible.** Where existing physical constraints on existing facilities make it impracticable for altered elements, spaces, or facilities to fully comply with the requirements for new construction, compliance is required to the extent practicable within the scope of the project. Not applicable to new construction. Also referred to as “Maximum Extent Practicable.”
- **Mobility Device.** Any assistive technology or device that aids the movement of people with a physical impairment. Examples include lift chairs, wheelchairs, scooters, etc.
- **Operable Part.** A component of an element used to insert or withdraw objects, or to activate, deactivate, or adjust the element.
- **Other Power-Driven Mobility Device (OPMD).** Any mobility device powered by batteries, fuel, or other engines that is used by individuals with mobility disabilities for the purpose of locomotion, whether or not it was designed primarily for use by individuals with mobility disabilities. OPMD’s may include electronic personal assistance mobility devices, such as the Segway ® Personal Transporter (PT), or any mobility device that is not a wheelchair and is designed to operate in areas without defined pedestrian routes.
- **Pedestrian.** A person afoot, using a mobility device, or using another power-driven mobility device (OPMD).
- **Pedestrian Access Route (PAR).** A continuous and unobstructed path of travel provided for pedestrians with disabilities within or coinciding with a pedestrian circulation path.
- **Pedestrian Circulation Path.** A prepared exterior or interior surface provided for pedestrian travel in the public right of way.



- **Pedestrian Ramp.**s The ramp, or ramp run, is the sloped section (minimum 48 inches wide) that individuals who use wheelchairs travel up and down when transitioning between the street and the sidewalk.
- **PROWAG.** An acronym for the U.S. Access Board's proposed Public Rights of Way Accessibility Guidelines for the design, construction, and alteration of pedestrian facilities in the public right of way.
- **Qualified Historic Facility.** A facility that is listed in or eligible for listing in the National Register of Historic Places or designated as historic under an appropriate state or local law.
- **Running Slope.** The grade that is parallel to the dominant direction of pedestrian travel.
- **Sidewalk.** A paved pathway paralleling roadway that is intended for pedestrian travel.
- **Shared-Use Path.** A paved travel-way separated from motor vehicle traffic by an open space or barrier and either within the right of way or in an independent right of way. Refer to Chapter 13 of this Guide for more information on Shared-Use Path Design.
- **Technically Infeasible.** With respect to an alteration of a building or existing facility, something that has little likelihood of being accomplished because existing structural conditions would require removing or altering a load-bearing member that is an essential part of the structural frame; or because other existing physical or site constraints prohibit modification or addition of elements, spaces, or features that are in full and strict compliance with minimum requirements.
- **Turning Space.** A circular or T-shaped turning space that will allow a wheelchair to make a 180 degree or 360 degree turning movement at a minimum of a 60-inch diameter.
- **Vertical Surface Discontinuities.** Vertical differences in level between two adjacent surfaces.
- **Vibrotactile.** Relaying information to the user through the perception of vibration or touch.

## 12.2 ADA Accessibility Requirements, Standards, and Guidelines

The ADAAG and the PROWAG are not requirements of the ADA, but they serve as the standards and guidelines by which compliance of the law is measured. Generally, the ADA law requires:

- New construction to be accessible.
- Alterations to existing facilities that are within the scope of a project to provide accessibility to the maximum extent feasible.
- Existing facilities that have not been altered shall not deny access to persons with disabilities.

### 12.2.1 New Construction Project Requirements

All new construction projects where pedestrian demand is exhibited must incorporate appropriate pedestrian facilities that are accessible to persons with disabilities. New construction projects can mitigate constraints through good planning and design practices. Project budget or limited scopes



are not an acceptable reason to fail to provide compliant accessible facilities during new construction.

### 12.2.2 Alteration Project Requirements PROWAG (R202 & R203)

Whenever existing facilities are altered, each altered element must meet the most current accessibility standard if it is within the scope of the alteration project. If elements are within a project's limits and scope but are not accessible, they must be made so. For example, if a project is resurfacing a roadway and curb ramps are missing at pedestrian crossings, compliant curb ramps must be incorporated into that project because that project affected the crossing served. That same project would not be required to install pedestrian push buttons if the existing signals are to remain, because that work is outside of the original resurfacing scope.

Where existing physical constraints make it impractical for facilities to comply with the current standard, improvements must be made to provide accessibility to the maximum extent practical within the scope and limits of the project

Alteration roadway projects shall not intentionally skip or "gap" pedestrian elements to avoid triggering the requirement to make ADA improvements.

Only the altered portion of a facility is required to be made compliant at the time of a project. If elements are altered or added but the pedestrian circulation path is not altered, the pedestrian circulation path is not required to be made accessible. However, it is often beneficial to improve surrounding unaltered facilities while construction forces are mobilized. When possible, consideration should be given to making nearby facilities accessible. The alteration of a facility may affect the usability of an adjoining facility and additional improvements can at times be unavoidable. An alteration project shall not decrease accessibility, or the accessibility to a connecting or adjacent building or site, below the current standards required of new construction during the time of the alteration. (PROWAG R202.3). These considerations should be taken into account during project scoping.

### 12.2.3 Alterations - PROWAG (R202)

All alteration projects must remove existing pedestrian access barriers. For example, projects must install curb ramps at locations where they are missing if they are within the limits of the altered area.

Examples of alteration projects include, but are not limited to:

- Addition of new layers of asphalt.
- Mill and fill / mill and overlay.
- Rehabilitation and reconstruction.
- Cape seals.
- Micro surfacing and thin lift overlays.
- Widening.
- Bridge projects.



Use these links for the USDOT’s technical assistance information regarding what treatments or combinations thereof constitute alterations:

- [https://www.fhwa.dot.gov/civilrights/programs/doj\\_fhwa\\_ta.cfm](https://www.fhwa.dot.gov/civilrights/programs/doj_fhwa_ta.cfm)
- [https://www.fhwa.dot.gov/civilrights/programs/doj\\_fhwa\\_ta\\_glossary.cfm](https://www.fhwa.dot.gov/civilrights/programs/doj_fhwa_ta_glossary.cfm)
- [https://www.fhwa.dot.gov/civilrights/programs/ada\\_resurfacing\\_qa.cfm](https://www.fhwa.dot.gov/civilrights/programs/ada_resurfacing_qa.cfm)

The USDOT prepared the graphic shown in Figure 12-1 to help illustrate what items may be considered maintenance or alterations. If two maintenance items are performed at the same time, they may rise to the level of an alteration.

The technical assistance from the USDOT should be consulted when determining whether an item(s) is considered maintenance or an alteration.

Figure 12-1 Maintenance vs. Alteration for Surface Treatment Projects



#### 12.2.4 Alterations to Qualified Historic Facilities – PROWAG (R202.3.4) Non- Alteration Project Requirements

Activities that are considered normal maintenance do not require simultaneous improvements for accessibility under the ADA. The USDOJ and USDOT offer the following guidance:

“What kinds of treatments constitute maintenance rather than an alteration?”

Treatments that serve solely to seal and protect the road surface, improve friction, and control splash and spray are considered to be maintenance because they do



not significantly affect the public's access to or usability of the road. Some examples of the types of treatments that would normally be considered maintenance are: painting or striping lanes, crack filling and sealing, surface sealing, chip seals, slurry seals, fog seals, scrub sealing, joint crack seals, joint repairs, dowel bar retrofit, spot high-friction treatments, diamond grinding, and pavement patching. **In some cases, the combination of several maintenance treatments occurring at or near the same time may qualify as an alteration and would trigger the obligation to provide curb ramps.” (Emphasis added)**

*Source: Department of Justice/Department of Transportation Joint Technical Assistance<sup>1</sup> on the Title II of the Americans with Disabilities Act Requirements to Provide Curb Ramps when Streets, Roads, or Highways are Altered through Resurfacing (USDOJ, USDOT.)*

Generally, maintenance activities are considered those actions that are intended to preserve the functionality or condition of an asset without increasing its capability or structural capacity.

Emergency repairs, such as interim paving or patching, would not trigger the requirement to upgrade or install accessible pedestrian facilities.

### 12.2.5 Technically Infeasible

Site constraints can make it impractical to make facilities fully compliant with the standards, so improvements at those locations can be deemed “technically infeasible” when sound engineering judgement is exercised. When full compliance is deemed technically infeasible, facilities being altered should be made accessible to the maximum extent practicable. If a site cannot meet accessibility standards, the proper documentation procedures should be followed.



Use this link for CDOT's ADA Resources for Engineers:

<https://www.codot.gov/business/civilrights/ada/resources-engineers>

---

For example, should a hypothetical curb ramp be constrained by a historic property, the designer needs to prepare a Curb Ramp Variance Support Document (on CDOT's ADA Resources for Engineers webpage) to prepare documentation for the affected ramp. The Curb Ramp Variance Support Document should be initiated as early as possible so the variance review does not hinder the project schedule.

Examples of site constraints that may make it technically infeasible to make a facility fully compliant include:

- Underground structures or utilities that would have to be altered to make a facility compliant and would expand the project scope.
- Adjacent development or buildings that would need to be moved or altered to make a facility fully compliant.
- Required improvements that would alter the status of a historic property.



- Drainage that could not be maintained if an area is made fully accessible.
- Underlying terrain that would require significant expansion of the project scope to achieve full compliance. An example would be altering a roadway profile to make the cross slope of a crosswalk fully compliant.

Project scope, not cost, should determine when existing constraints make an item technically infeasible. This has been supported by decisions from the Dept. of Justice. For example, a resurfacing project that does not include the relocation of existing utilities may be justified in providing a facility that does not comply fully with the standards and is accessible to the maximum extent feasible if those utilities prohibit compliance. However, a widening project that includes right of way acquisition and utility relocations would not be able to use that same justification because those elements are within the scope of the project.

### 12.2.6 Unaltered Existing Facilities & the ADA Transition Plan

Facilities that are not to be addressed in any current or planned CDOT projects are to be addressed as described in CDOT's ADA Transition Plan (refer to Section 12.1.1 of this chapter).

## 12.3 Technical Requirements for Accessibility

### 12.3.1 Pedestrian Access Route Technical Requirements - PROWAG (R302)

The following section provides detailed technical criteria and guidance for the development of accessible pedestrian routes (PAR). The material in this section is derived from information found in the PROWAG and other relevant sources. It is the intent of this chapter to be consistent with all of the criteria provided in existing federal or CDOT standards. This section is intended to provide the most relevant technical requirements in one location and provide additional guidance and best practices when possible. The minimum and maximum values that are provided are taken from the PROWAG. Target values may also be provided. Designing features to values other than the allowable minimums or maximums allows for adjustments in the field and provides flexibility during construction.

A pedestrian access route (PAR) is a continuous and unobstructed path of travel intended to provide accessibility for pedestrians with disabilities. A pedestrian access route shall be provided where a prepared surface has been constructed for pedestrian travel within the right of way.

Examples of areas that may be considered a PAR include:

- Pedestrian street crossings at intersections (marked or unmarked crosswalks) and mid-block locations.
- Curb ramps.
- Pedestrian overpasses and underpasses.
- Sidewalks.
- Shared-use paths.
- Elevators.

- Doorways.
- Accessible parking space access aisles.

The following describes the common requirements of the PAR.

### 12.3.1.1 Continuous Width PROWAG (R302.3)

(R302.3) The continuous width of the PAR shall be 4 feet minimum, exclusive of the curb. For example, where a pedestrian access route makes a 90-degree turn, it should be widened to 5 feet to accommodate the continuous passage of a wheelchair (e.g., pedestrian design vehicle). CDOT projects should have minimum 5-foot sidewalks, exclusive of the curb, unless unique constraints are present. If the clear width of the PAR is less than 5 feet, passing spaces shall be provided at a maximum of 200-foot intervals. If passing spaces are provided, they shall be 5 feet by 5 feet minimum. The clear width of a pedestrian refuge island shall be 5 feet minimum.

Passing Space - Curb Ramps, Medians, Pedestrian Refuge Islands & Shared Use Paths - PROWAG (R302.3.1, R302.3.2 and R302.4). Figure 12-2 illustrates passing space requirements.

Figure 12-2 Passing Spaces

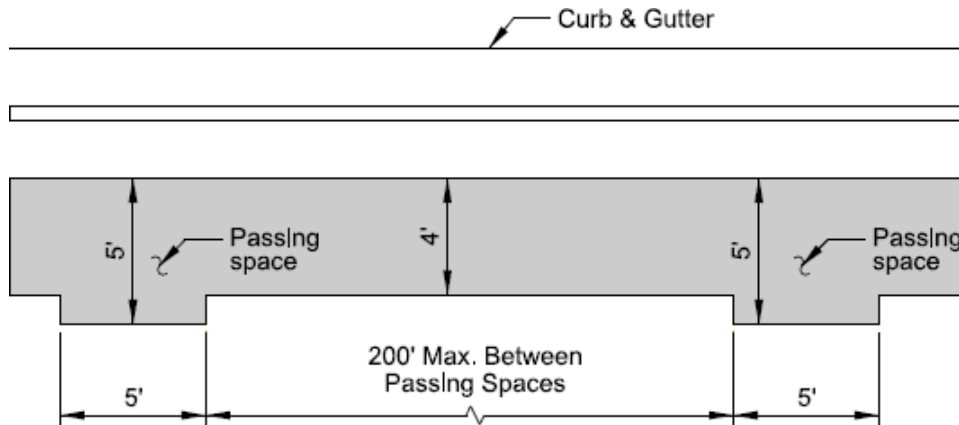

### 12.3.1.2 Pinch Points

Reduction in Access - PROWAG (R202.3.3)

Pinch points within the PAR shall not be less than 34 inches in width and not exceed 24 inches in the direction of pedestrian travel as shown in Figure 12-3. A study by the U.S. Access Board determined that a 34-inch width allowed 95% of the wheel mobility users to pass the obstruction in the study areas (Anthropometry of Wheel Mobility Project, US Access Board). Pinch Points are permitted in constrained areas on maintenance and alteration projects only with approval of the Project Engineer. **Pinch points are not acceptable in new construction.**



Figure 12-3 Pinch Point

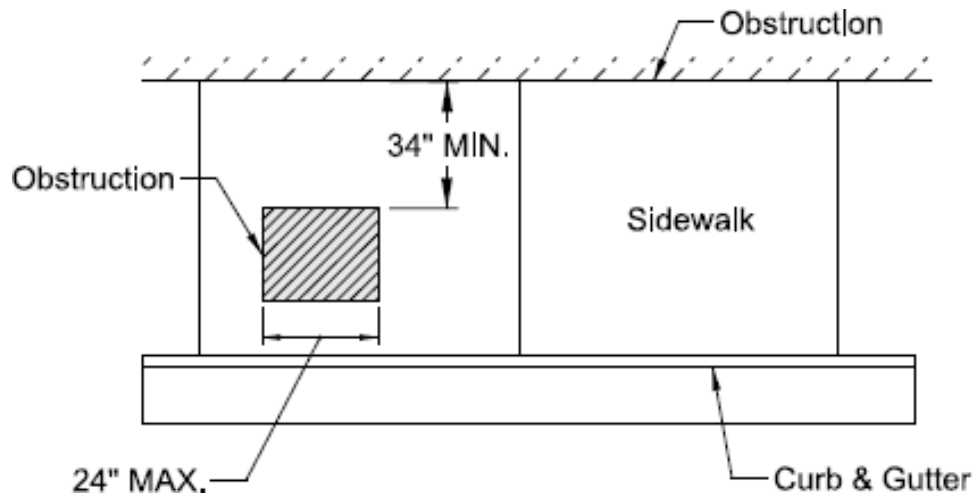

### 12.3.1.3 Surface – PROWAG (R302.7)

A standard test has not been defined to measure slip resistance or stability, so sound engineering judgement must be applied to ensure that users with mobility impairments can traverse the PAR. The preferred surface for pedestrian walkways and sidewalks is concrete with a broom finish. Examples of noncompliant surfaces include cobblestones, split-faced stone, loose sand, dirt, gravel, and any other similar irregular surface. Grade breaks within curb ramps shall be flush, as shown in Figure 12-4. Grade breaks in curb ramps shall be perpendicular to the path of travel. The characteristics of the surface when wet should be taken into consideration when determining if a surface is firm, stable, and slip resistant.

There exists an allowance for vertical surface discontinuities for occasional expansion joints and objects such as utility covers, vault frames, and gratings that cannot be located in another portion of the sidewalk or outside the PAR. Objects such as utility covers, vault frames, and gratings should not be located on curb ramp runs, blended transitions, turning spaces, or gutter areas within the PAR. This may not always be possible in alterations, but it should be avoided when possible. Vertical surface discontinuities between unit pavers should be minimized.

Vertical surfaced discontinuities shall be a 0.5-inch maximum. When there is a surface discontinuity between 0.25 inch and 0.5 inch, the discontinuity shall be beveled at 2:1. The bevel shall be provided for the entire length of the discontinuity

Figure 12-4 Allowable Vertical Discontinuities

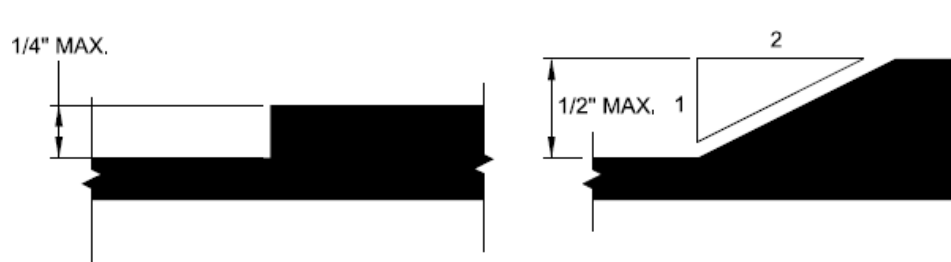



#### 12.3.1.4 PAR Vertical Alignment – PROWAG (R302.7.1)

Where the PAR crosses a rail at grade, the pedestrian access route should be level with the top of the rail.

#### 12.3.1.5 Openings and Horizontal Gaps – PROWAG (R302.7.3)

The use of grates, handholes, and inlets within the PAR, especially curb ramps and other pedestrian crossings, should be avoided.

*Figure 12-5 Horizontal Openings in Grates*

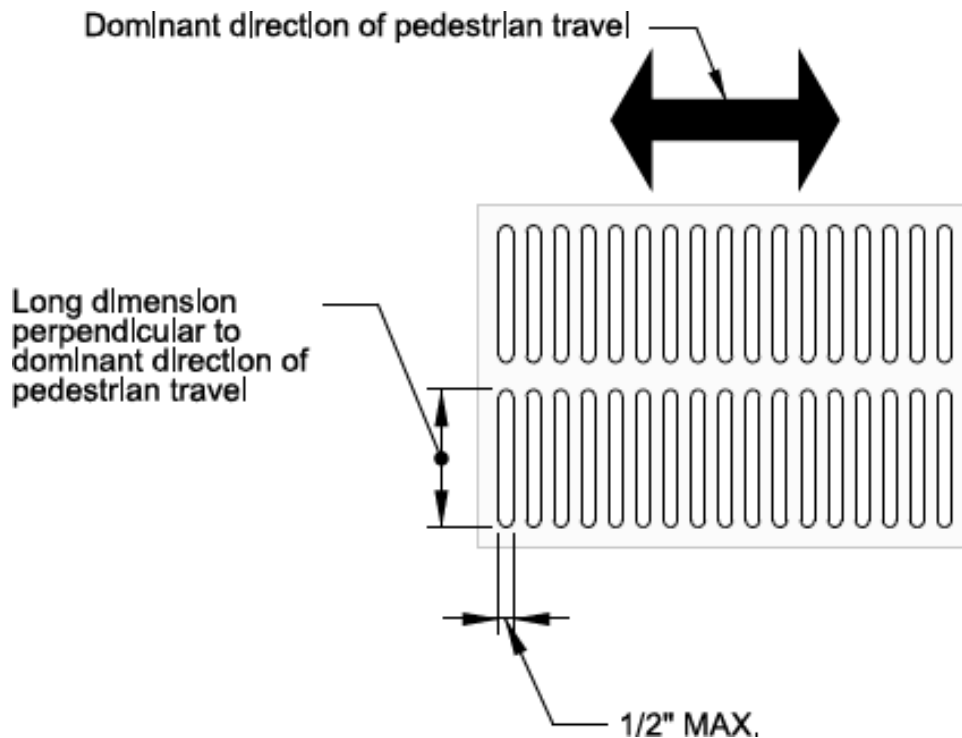

#### 12.3.1.6 Flangeway Gaps - PROWAG (R302.7.4)

When the PAR crosses a railway the horizontal gap between the pedestrian surface and the rail shall be no more than 2.5 inches on a non-freight railway and no more than 3 inches on a freight railway.

Figure 12-6 Flangeway Gaps at Pedestrian At-Grade Rail Crossings

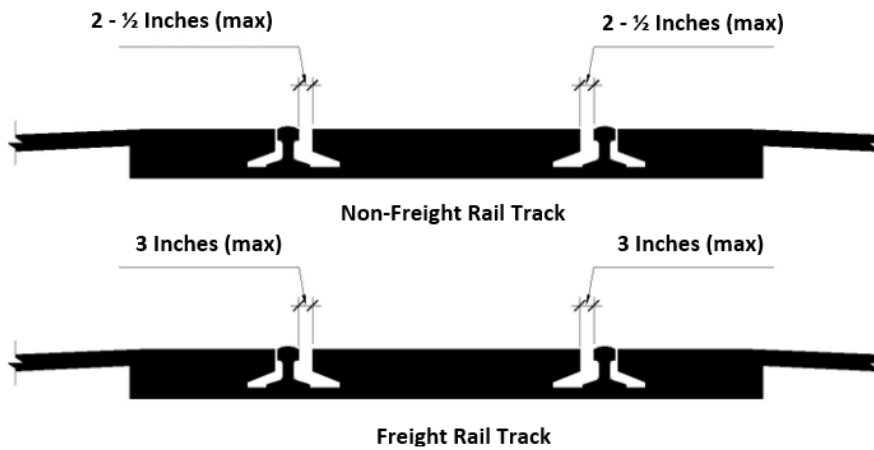

### 12.3.1.7 Protruding Objects - PROWAG (R402)

Objects with leading edges more than 2.25 feet and not more than 6.7 feet above the finish surface shall protrude 4 inches maximum horizontally in the pedestrian circulation paths.

### 12.3.1.8 Shared-Use Path Protruding Objects - PROWAG (R210.3)

Figure 12-7 Protruding Objects

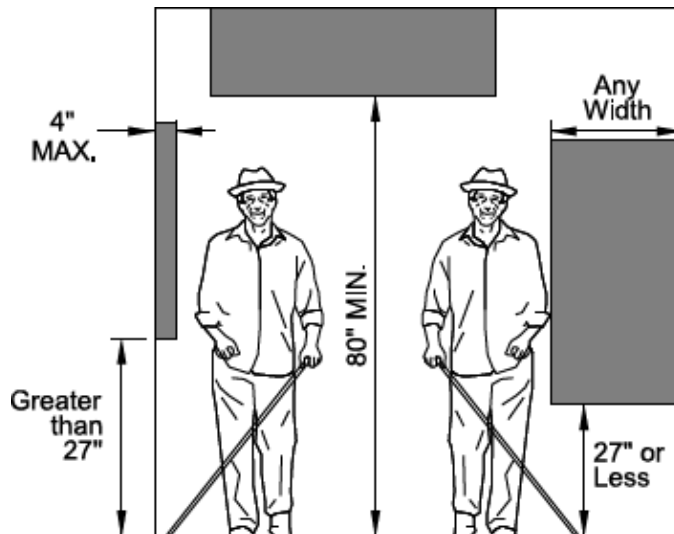

### 12.3.1.9 Reduced Vertical Clearance - PROWAG (R402.4)

Guardrail or other barriers to pedestrian travel shall be provided where vertical clearance is less than 6.7 feet high. The leading edge of the barrier or guardrail shall be at least 27 inches tall when measured from the finished floor surface.

Figure 12-8 Protection from Stairways

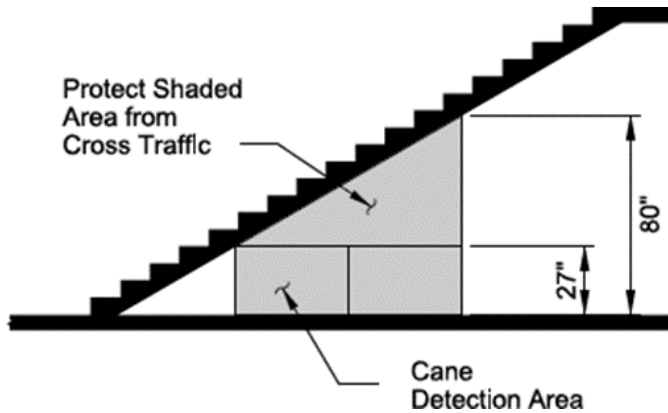

### 12.3.1.10 Post Mounted Objects PROWAG (R402.3)

When objects such as signs are mounted on free-standing posts and the objects are 2.25 feet minimum and 6.7 feet maximum above the finished surface. The objects shall overhang pedestrian circulation paths by no more than 4 inches measured horizontally from the post. This may require the addition of a raised base to protect pedestrians from encroaching the hazard area.

Figure 12-9 Post-Mounted Objects

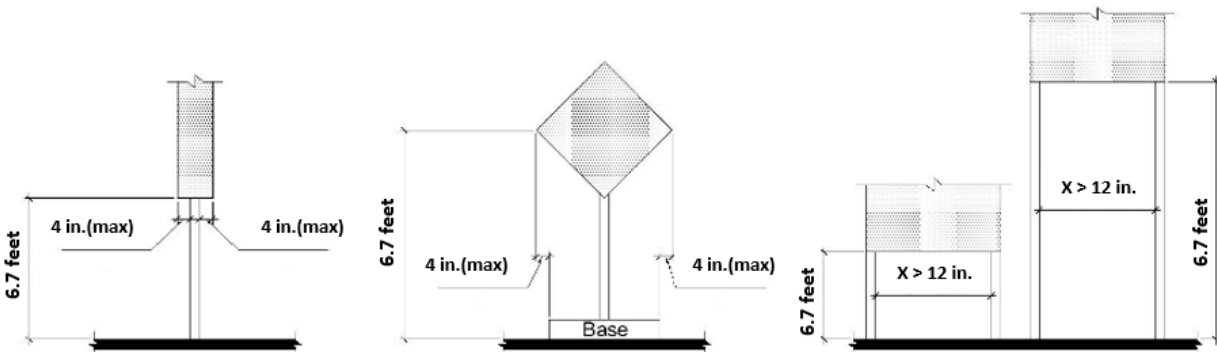

### 12.3.1.11 Grade – PROWAG (R302.5 through 302.5.5)

Maximum slope for grade is 5%, but designers should target grade slopes of PARs and Pedestrian Street Crossings of 4.5% to provide flexibility during construction.

### 12.3.1.12 Cross Slope - PROWAG (R302.6)

The cross slope of the PAR is measured perpendicular to the direction of travel and shall not exceed 2.0%.

PROWAG has set limits for the maximum allowable cross slope at pedestrian street crossings. At these locations the roadway longitudinal grade becomes the cross slope of the pedestrian crossing. The maximum allowable cross slope for pedestrian street crossings is dependent on the type of vehicular traffic control present at the crossing. At times, these requirements limit the



longitudinal grade of the roadway and require a “tabled crosswalk” at the intersection. Pedestrian crossings without yield or stop control are defined as those without a yield or stop sign, or where a traffic signal is designed to remain in the green phase. requirements for cross slope of pedestrian street crossings are found at R302.6.1.

- **Intersection leg with yield or stop control.** The pedestrian street crossing must not have a cross slope greater than 2.0%.
- **Intersection leg without yield or stop control.** The pedestrian street crossing must not have a cross slope greater than 5.0%.
- **Mid-block pedestrian crossing.** The pedestrian street crossing is allowed to have a cross slope equal to the street or highway grade.

Figure 12-10 Pedestrian Street Crossing Cross Slope

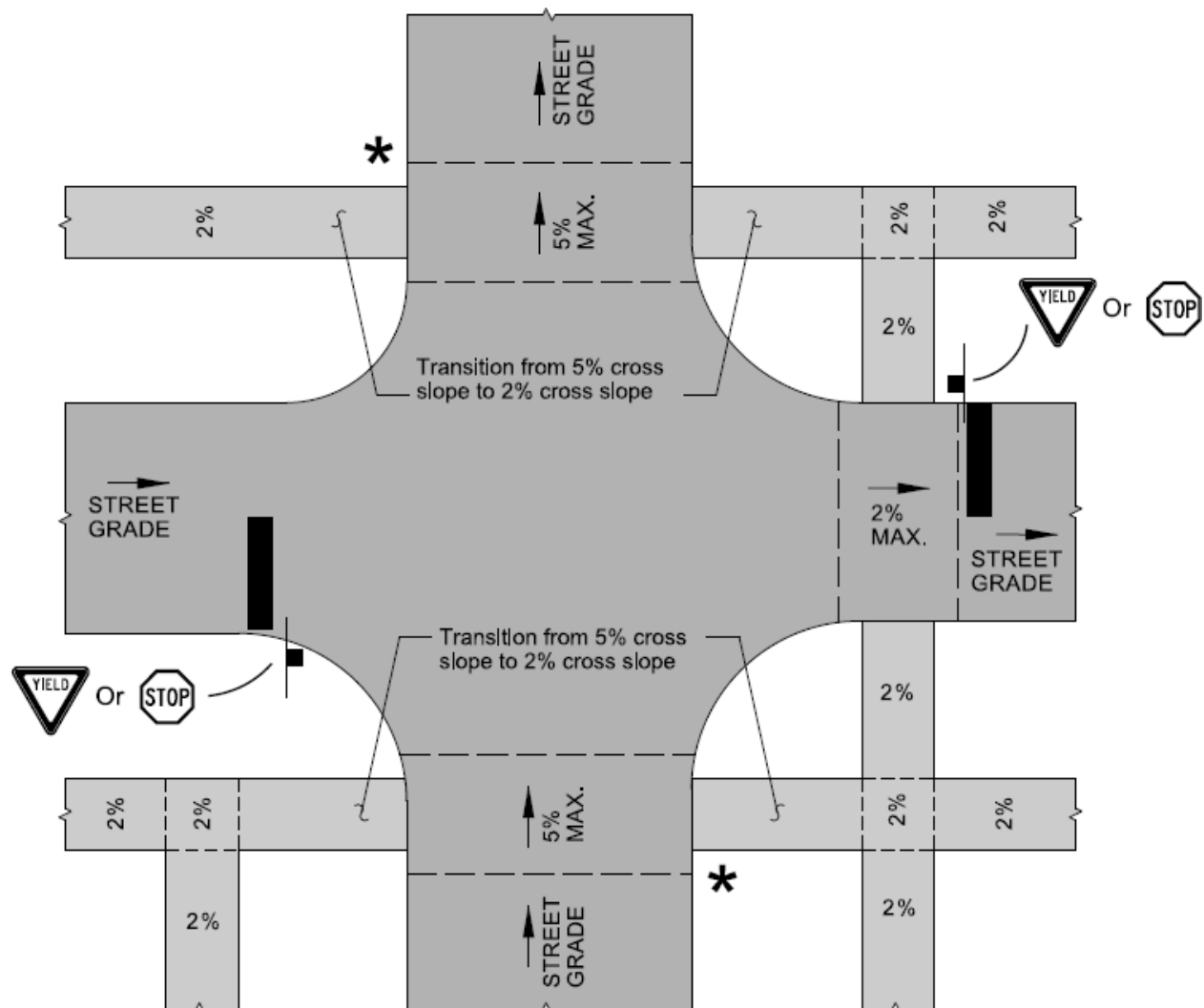

\* Streets without stop or yield control, or with a traffic light which is designed to remain in the green phase, shall have a maximum pedestrian street crossing cross slope of 5% (R302.6)



## 12.4 Curb Ramp General Information

Curb ramps are intended to provide pedestrians access between the sidewalk and street when a curb face or vertical change in elevation is present. For new construction or on streets being altered, curb ramps are mandated by Title II of the ADA. In addition to providing access for those with mobility impairments, curb ramps make street crossings easier for pedestrians without disabilities including people pushing strollers, riding bicycles, and making deliveries.

Most curb ramps contain a combination of the following core elements: approach, ramp runs, flares, vertical curb faces, landings or turning spaces, transition between the ramp run and gutter, and detectable warnings. These common elements can be configured in several ways to create a variety of curb ramp designs. Generally, curb ramps can be grouped into three categories: perpendicular ramps, parallel ramps, and blended transitions.



Use this link to access CDOT's ADA Resources for Engineers:

<https://www.codot.gov/business/civilrights/ada/resources-engineers>

Figure 12-11 Curb Ramp Elements

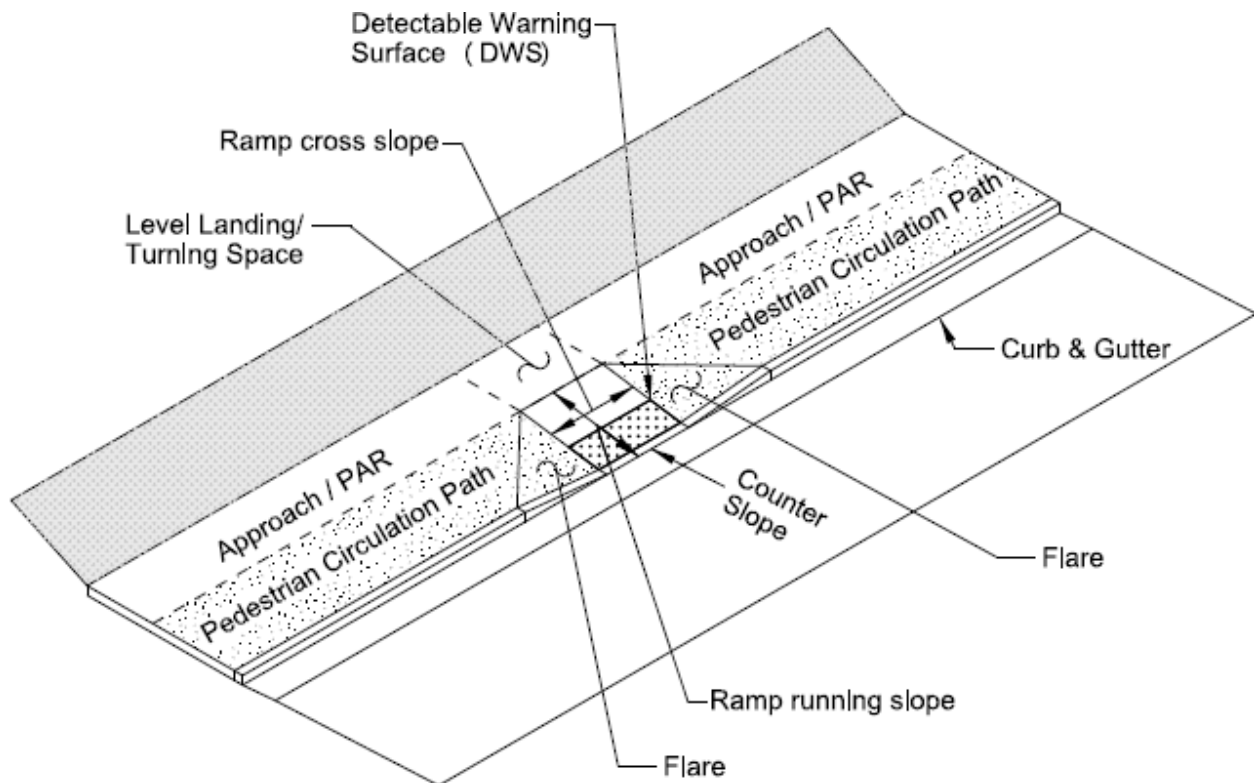

Curb ramps should not be placed in locations where pedestrians must cross drainage inlets or ponding water. Designers should consider the location of drainage inlets relative to any curb



ramps that are being installed. Locating or moving drainage inlets upstream of curb ramps helps eliminate ponding and should be a consideration during design. Curb ramps should be located away from the low point of a curb return when possible.

Often curb ramp locations will be determined by the existing site constraints; however, the preferred design is to have a separate curb ramp aligned with each crossing. In new construction, where existing constraints do not exist, one curb ramp for each crossing is required. On CDOT projects, a single diagonal curb ramp (on the apex) will only be permitted on reconstruction and alteration projects where physical site constraints prevent two curb ramps from being installed. Designers should make every attempt to provide one ramp per crossing.



*If there is an uncontrolled or mid-block crossing in a project, a designer may request a traffic analysis to determine volumes and speed, and a crash analysis to determine any crash patterns, to understand if the location may need additional enhancements, such as pedestrian rapid flashing beacons, to improve pedestrian visibility and reduce crash potential.*

Diagonal curb ramps present several challenges of which designers should be aware:

- Providing a level clear space at the bottom of a ramp is often difficult to achieve.
- Diagonal ramps present a problem for pedestrians because pedestrians are directed towards the middle of the intersection. This may be particularly troublesome for pedestrians with vision impairments who cannot determine the correct alignment of the street crossing. They create uncertainty for motorists who cannot determine which direction the pedestrian is trying to cross. As a result, motorists are less likely to yield to pedestrians trying to cross the street.

Figure 12-12 Preferred Curb Ramp Placement

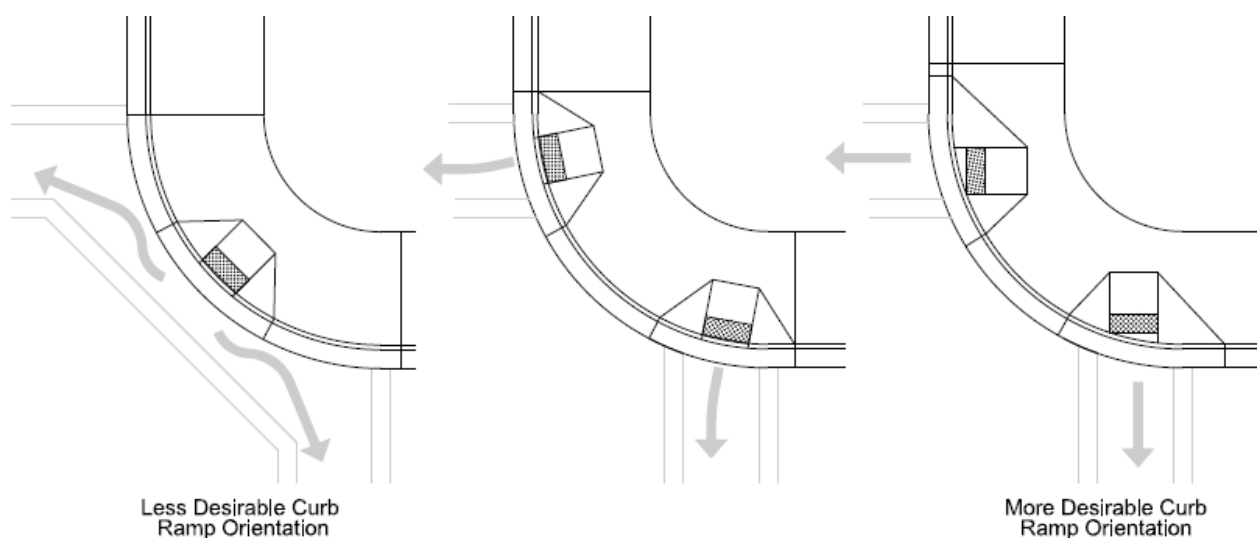





## 12.5 Curb Ramp Types

Perpendicular curb ramps are oriented perpendicular to the curb face or vertical elevation change they traverse. Perpendicular ramps have a turning space located at the top of the ramp to allow users to get oriented in the direction of the crossing before travelling down the ramp.

Perpendicular curb ramps are generally the preferred design to accommodate pedestrians if there is enough space for their installation. When possible, perpendicular ramps should be aligned with the pedestrian street crossing they serve. When ROW is limited for the installation of a perpendicular curb ramp, consideration could be given to the use of parallel curb ramps, particularly in retrofit scenarios.

Figure 12-13 Perpendicular Curb Ramp Examples

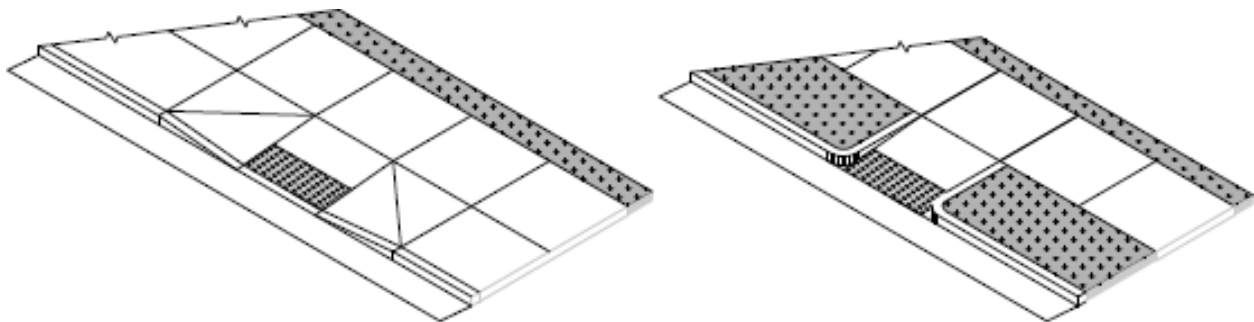

Parallel curb ramps are oriented parallel to the curb face or elevation change which they traverse. These are often used when there is little room between the curb and the back of sidewalk for a perpendicular curb ramp and turning space. Parallel curb ramps transition down to the roadway elevation and require individuals to traverse multiple ramp surfaces when traveling along a sidewalk. To avoid this, it is preferred that perpendicular ramps be used where possible.

Additionally, because the turning space of a parallel ramp is at the roadway grade, sedimentation and drainage can be an issue with parallel style curb ramps.

Figure 12-14 Parallel Curb Ramp Example

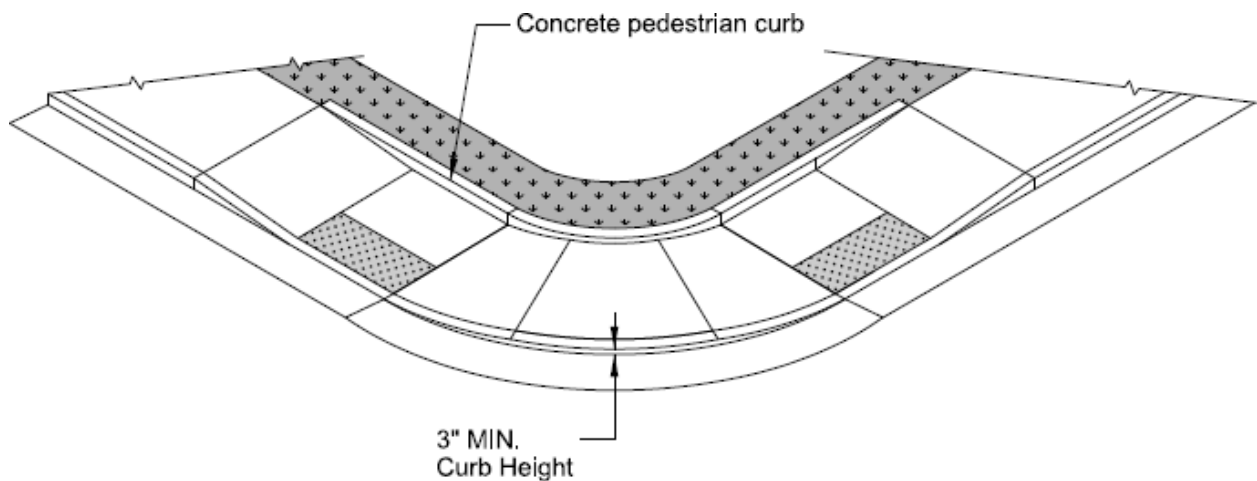

In a blended transition, the elevation of the sidewalk is slowly lowered to the street level at the corner. The maximum grade of a blended transition is 5.0% and the maximum cross slope is 2.0%. Blended transitions are typically seen in dense urban areas such as central business districts, around stadiums, or in main street environments. Blended transitions present an opportunity for turning vehicular traffic to traverse the sidewalk and thereby pose a safety risk to pedestrians. Blended transitions also create challenges for the visually impaired because they provide limited directionality. Blended transitions should be used sparingly, and only where appropriate.

*Figure 12-15 Blended Transition/Depressed Corner Example*

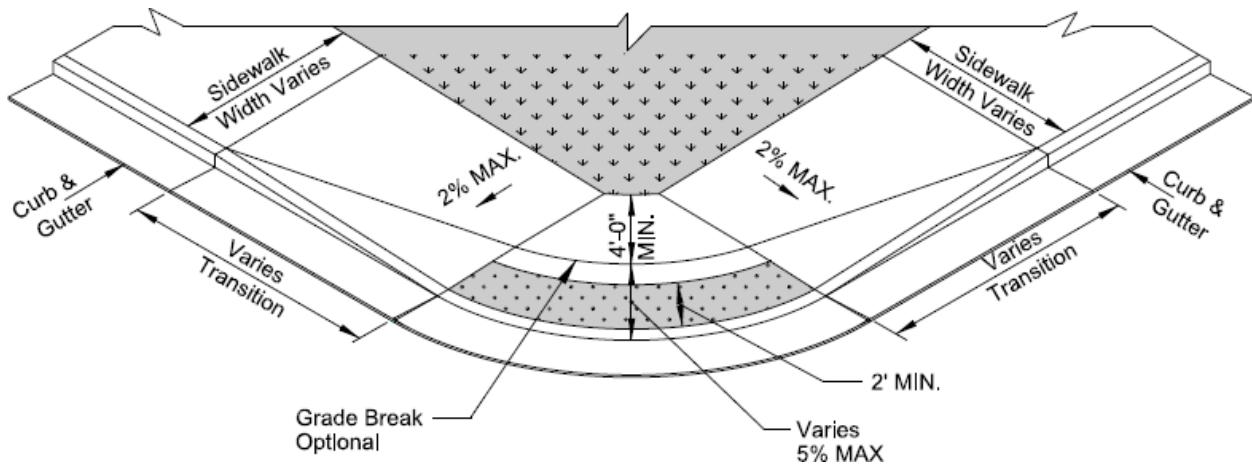

## 12.6 Curb Ramp Technical Requirements

Although there are several types and configurations of curb ramps, including combinations of the types mentioned above, they all have the following general requirements:

### 12.6.1 Curb Ramp Running Slope – PROWAG (R304.2.2, R304.3.2 & R304.4.1)

Curb ramps should be designed to a maximum running slope of 7.5% to 8.0% to allow for construction tolerances. The running slope of a turning space should be design to a maximum of 1.5% to 1.8% to allow for construction tolerances. For more detailed information refer to PROWAG R304.2.2.

### 12.6.2 Curb Ramp Cross Slope – PROWAG (R304.5.3)

**Designers should target a cross slope of 1.5% to provide for flexibility during construction.** For street crossings that do not have stop or yield control, or at mid-block crossings, the cross slope is allowed to match the street or highway grade. See the PAR cross slope requirements for more information.



### 12.6.3 Curb Ramp Width – PROWAG (R304.5.1)

The clear width of curb ramp runs, turning spaces, and blended transitions shall be 4 feet minimum. On CDOT projects, curb ramp runs, turning spaces, and blended transitions should be 5 feet in width or greater.



*If the sidewalk the curb ramp is servicing is wider than 5 feet, the ramp should match the width of the facility it is servicing. Curb ramps that service shared-use paths should match the width of the path.*

### 12.6.4 Grade Breaks - PROWAG (R304.5.2)

When grade breaks are not perpendicular to the path of travel, they pose challenges to pedestrians using a mobility device, such as wheelchairs and walkers, because one wheel may strike or leave the ramp before the other.

*Figure 12-16 Curb Ramp Grade Breaks*

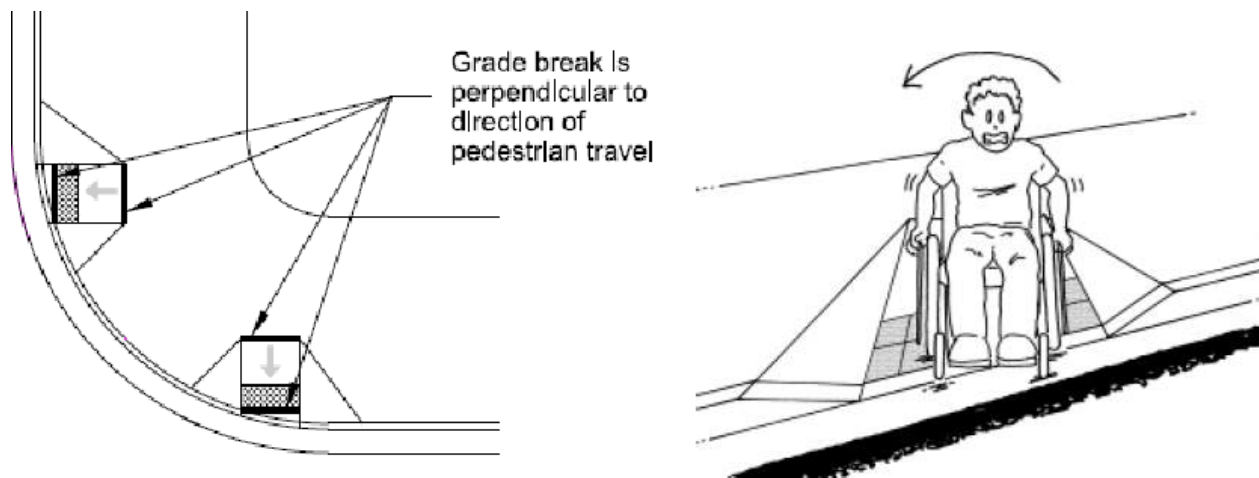

### 12.6.5 Curb Ramp Turning Spaces – PROWAG (R304.2.1 & R304.3.1)

Turning spaces allow users to maneuver on and off the curb ramp and are required at the top or bottom of a curb ramp. Turning spaces are required at the top of a perpendicular curb ramp and at the bottom of a parallel curb ramp. The maximum running slope and cross slope of turning spaces shall be 2.0%. Designers should target slopes of 1.5% to provide flexibility during construction. At mid-block crossings or locations without yield or stop control, the cross slope of the turning space is allowed to equal the roadway grade. Turning spaces shall be 4 feet by 4 feet minimum. If the turning space is constrained by a vertical element, such as a raised curb or other vertical obstruction, on one or more sides, provide 5 feet of turning space in the direction of the street crossing.



Use this link to access CDOT's M-608-1 standards for turning space requirements: [m-608-1-curb-ramps.pdf \(codot.gov\)](https://www.codot.gov/m-608-1-curb-ramps.pdf)

When the profile of the roadway being crossed has an excessive slope, the curb ramp cross slope should be transitioned slowly to the turning space. The transition shall be spread evenly over the length of the curb ramp.

Figure 12-17 Transitioning Steep Roadway Slopes

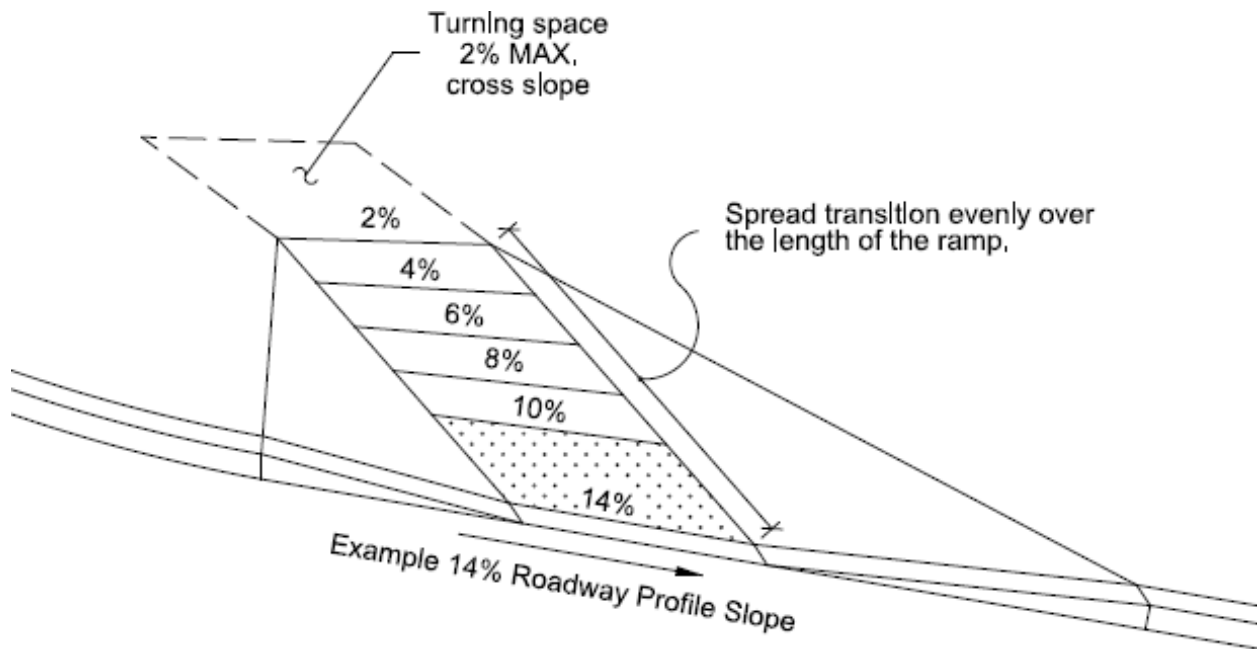

Figure 12-18 Street Grade at Curb Ramps Examples





### 12.6.6 Curb Ramp Clear Spaces – PROWAG (R304.5.5)

Beyond the bottom grade break of perpendicular ramps, a clear space 4-foot by 4-foot minimum shall be provided. This clear space must be within the pedestrian street crossing (crosswalk) and wholly outside of any vehicle travel lanes. Clear space should not be confused with turning space/landing space as it is a distinct concept.

*Figure 12-19 Perpendicular Curb Ramp Clear Spaces*

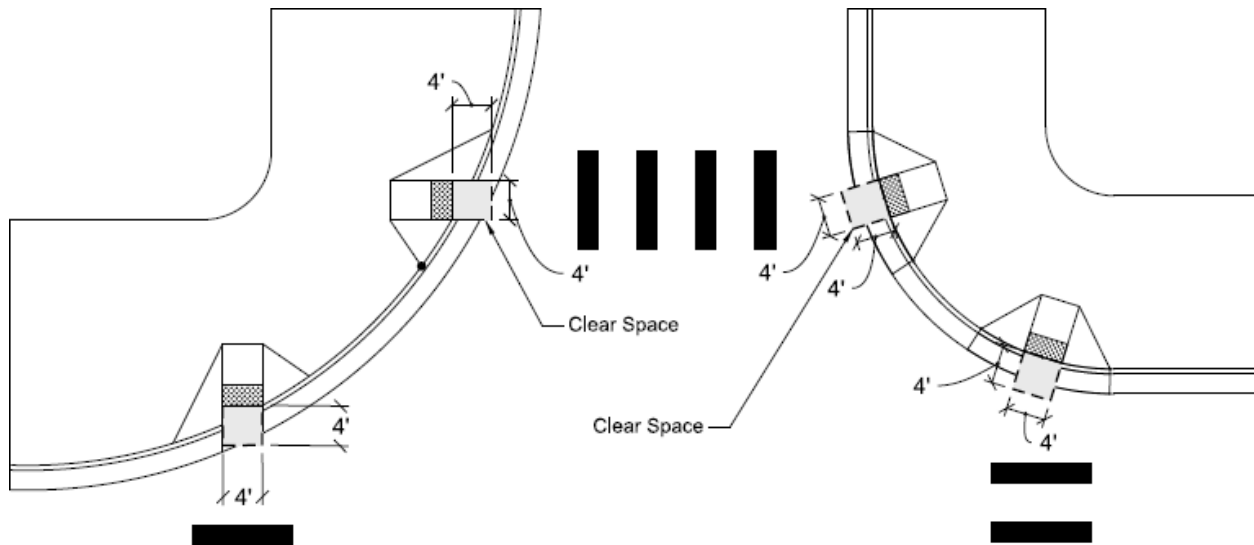

### 12.6.7 Flared Sides – PROWAG (R304.2.3)

Where a pedestrian can walk across a curb ramp, flared sides shall be provided to prevent a tripping hazard. Flared sides shall be sloped at 10.0% maximum and be measured parallel to the curb line. A best practice is to design flares with slopes between 8.0% and 9.0%. Flared sides are only required where the curb ramp abuts a portion of a pedestrian circulation path. If access to a ramp flare is blocked from pedestrian travel by an item such as street furniture or a utility, then consider a vertical or return curb.

A vertical curb face may be used if the ramp abuts a non-walkable surface. Vertical curb faces can be beneficial to pedestrians with visual disabilities because they align pedestrians in the direction of the street crossing. Flared sides may be used when the ramp abuts a non-walkable surface, in this situation the allowable slope of the flare is at the designer's discretion. Using flared sides can be beneficial in protecting the ramp from vehicle strikes such as snowplows, however, they do not provide the directionality benefits of vertical faces.





Figure 12-20 Flared Sides

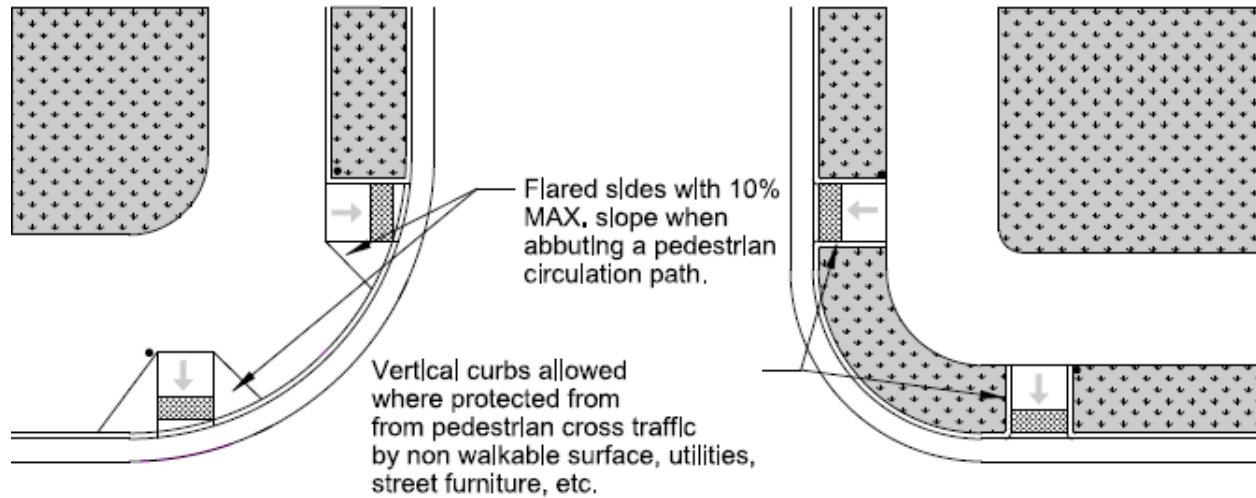

### 12.6.8 Counter Slope – PROWAG (R304.5.4)

The transition from the curb ramp to the roadway surface must be flush. The counter slope of 5.0% or less, a best practice would be to target less. The algebraic difference of the ramp run and the street counter slope shall not exceed 13.33% (8.33% and 5% respectively). A rapid change in grade at the bottom of a ramp run can be difficult for someone using a wheelchair to traverse. This may occur in limited instances through design of counter slope.

Figure 12-21 Curb Ramp Counter Slope Requirements

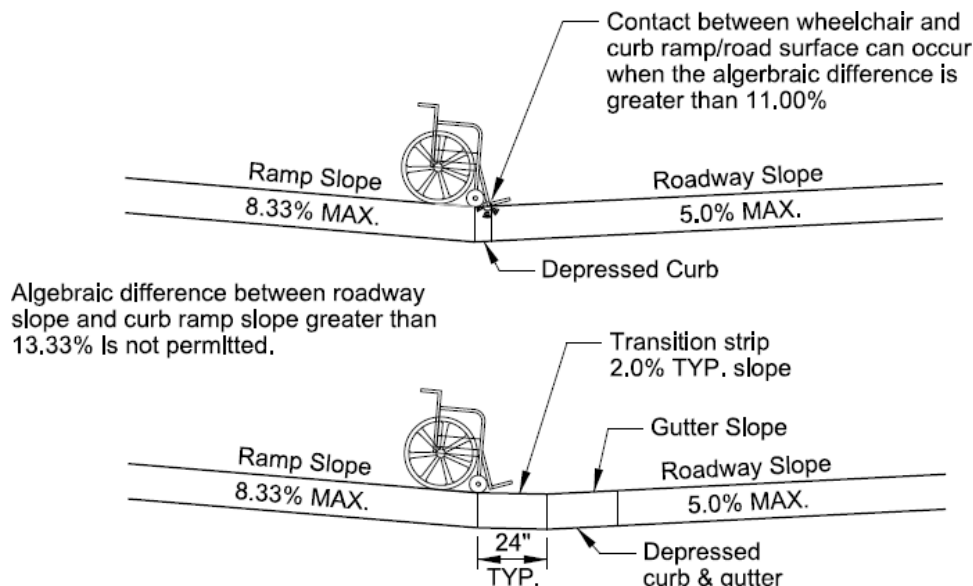

Provide a 24" transition strip when algebraic difference between gutter slope and curb ramp slope is greater than 13.33%.



## 12.7 Detectable Warning Surfaces – PROWAG (R305)

Detectable Warning Surfaces (DWS) provide an indication to individuals with disabilities that they are entering a potentially dangerous area. This is communicated through a distinct patterned surface consisting of truncated domes. DWS should be detectable by cane or underfoot and are intended to differentiate the boundary between the pedestrian realm and vehicular routes when a raised curb face is missing. The color of detectable warnings surfaces shall contrast visually with adjacent walking surfaces, either light-on-dark or dark-on-light.

The truncated dome pattern of the DWS should be aligned so that the rows of domes are parallel to the direction of pedestrian travel. This alignment allows people using wheelchairs to track between the domes and avoid excessive vibration, which can be uncomfortable to individuals with a spinal cord injury. The orientation of the truncated domes is not intended to provide wayfinding assistance (orient users in the direction of the crossing) for pedestrians with visual disabilities. While a best practice, this is not a requirement and cannot always be accomplished.

DWS shall extend 2 feet in the direction of pedestrian travel and are typically placed at the back of curb. DWS shall extend the full width of a curb ramp (excluding flared sides), blended transition, or turning space. DWS shall extend the full width of pedestrian rail crossings or shared-use path crossing. At boarding platforms for railways or buses, DWS shall be placed along the full length of the platform. At boarding areas at the sidewalk or street level the DWS shall extend the full length of the transit stop. When a border is required for installation, such as when pavers are used, the border shall be no more than 2 inches in width.

For the technical requirements of the truncated dome size and spacing, refer to PROWAG section R305.1 & CDOT Standard Plan M-608-1.

Of the DWS allowed on CDOT projects, pavers require the most ongoing maintenance over time. This should be considered when specifying their usage on a project.

### 12.7.1 Placement

#### 12.7.1.1 Pedestrian Street Crossings – PROWAG (R208.1 & R305.2)

Detectable warning surfaces must be installed at all pedestrian street and rail crossings. PROWAG recommends that DWS not be placed at residential driveway crossings or at locations where the pedestrian right of way continues across driveway aprons. However, it does recommend that DWS be placed at commercial driveways when yield or stop control is present. This guidance is not necessarily comprehensive and may be confusing to designers. For example, small commercial centers might have less driveway traffic than large apartment complexes but require DWS. Sound engineering judgement should be applied regarding the application of DWS at driveway crossings. Conditions that make a driveway function more like a street crossing may warrant the use of DWS, regardless of the land use category. Types of driveway locations that may warrant the use of DWS include:

- If there is the presence of a traffic control device that indicates the driveway functions more like a street crossing than a driveway (e.g., lane or pavement markings, signals, stop signs).

- Where a sidewalk descends to meet the grade of the street at the driveway crossing.
- Where the sidewalk changes material and ceases to be clearly defined as sidewalk, for example, changing from concrete sidewalk to asphalt that looks more similar to the street at the driveway.

### 12.7.1.2 Parallel Curb Ramps – PROWAG (R305.2.2)

On parallel curb ramps the DWS shall be placed in the turning space at the back of curb where the curb face is missing.

*Figure 12-22 Parallel Curb Ramp DWS Placement*

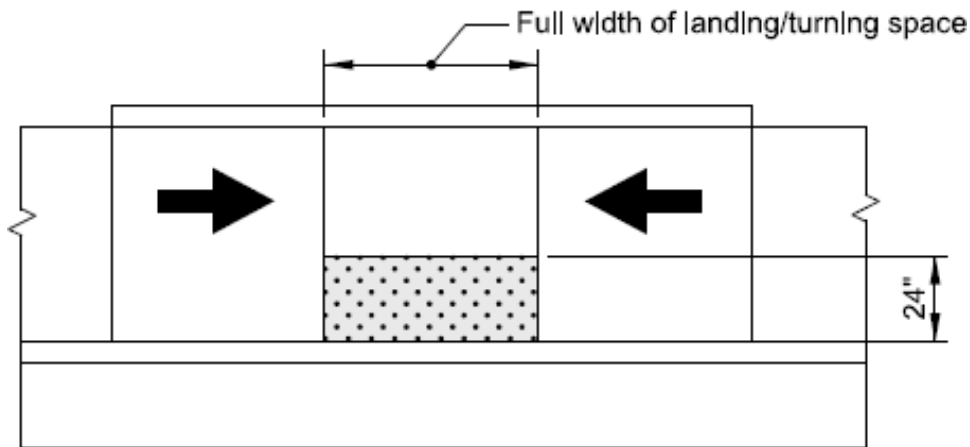

### 12.7.1.3 Perpendicular Ramps – PROWAG (R305.2.1)

The placement of the DWS on perpendicular curb ramps varies depending on the location of the grade break at the bottom of the ramp. Generally, the DWS is placed at the back of curb where the curb face is missing. In situations where the ramp is located on a radius and the grade break at the bottom of the ramp is less than 5 feet from the back of curb, the DWS is placed at the bottom of the ramp (refer to Figure 12-20 in this chapter).

Figure 12-23 Perpendicular Curb Ramp DWS Placement

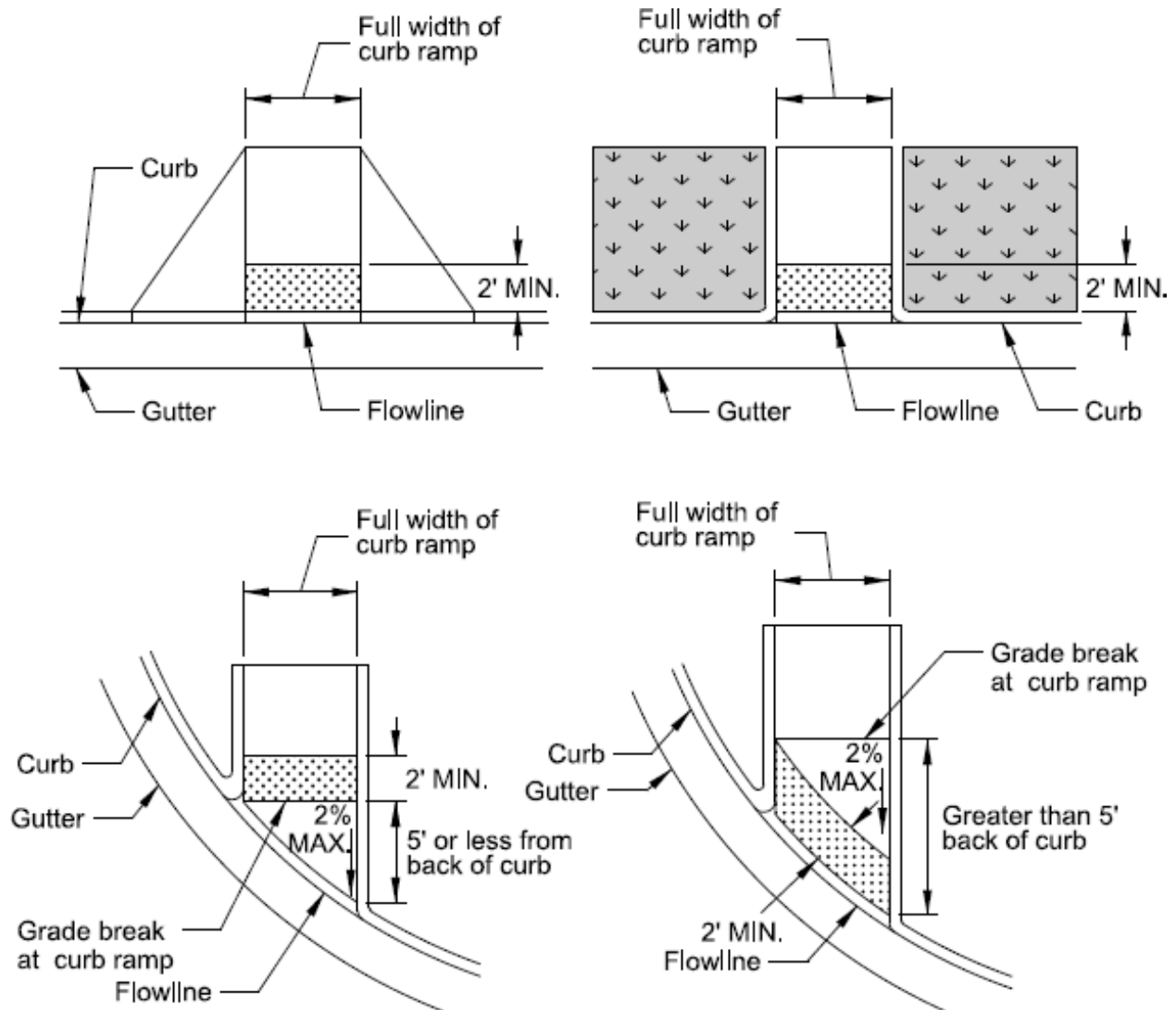

#### 12.7.1.4 Pedestrian Refuge Islands – PROWAG (R305.2.4)

When a pedestrian refuge island is 6 feet wide or greater from the face of curb to face of curb, DWS shall be installed. When installed, the detectable warning surfaces must be separated by a surface without DWS that is a minimum of 2 feet in length (parallel to pedestrian travel). If this 2-foot space cannot be provided, DWS shall not be installed because the island is not wide enough to be considered a pedestrian refuge and timing should be evaluated to allow pedestrians to cross safely and in accordance with the MUTCD.



Figure 12-24 Pedestrian Refuge DWS Placement

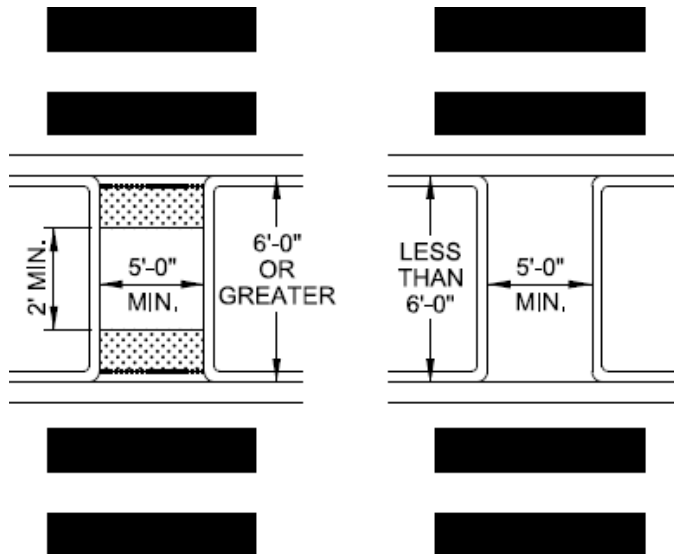

### 12.7.1.5 Pedestrian At-Grade Rail Crossings – PROWAG (R305.2.5)

Refer to PROWAG (R305.2.5), Figure 12-6 of this chapter, and CDOT Standard Plans - M & S Standards (CDOT, 2019) for more information. The designer should very carefully read the expectations for detectable warning requirements at at-grade pedestrian crossings, platforms, and alighting areas that are not on streets or highways.

## 12.8 Pedestrian Push Buttons

When pedestrian activated crossing controls (Push Buttons) are provided, they must meet the requirements set forth in the MUTCD, specifically sections 4E.08 through 4E.13. An accessible pedestrian signal (APS) is a device that communicates information to pedestrians about the street crossing through audible tones and vibrotactile surfaces. Operable parts on items such as pedestrian push buttons and APS shall comply with Section R403 of the PROWAG. The required clear space of 2.5-feet by 4-feet adjacent to the push button with a max cross slope of 2%. It is recommended for designers to plan for the location of the push button and associated 2.5-foot-by-4-foot clear space when designing the curb ramp. A best practice is to locate the push button post assembly in the middle of the 4-foot clear space dimension to better facilitate side reach.

Consistency throughout the pedestrian system is critical. On CDOT signal projects, the CDOT Accessible Pedestrian Signal Protocol should be used to determine if there is a need for an APS.



Use this link to view CDOT's Accessible Pedestrian Signal Protocol:  
<https://www.codot.gov/business/civilrights/ada/resources-engineers>



In addition to the requirements in the MUTCD and PROWAG, the following should be taken into consideration when installing pedestrian push buttons for pedestrian accessible routes:

- Pedestrian push buttons should be located as close as practical to the curb ramp they are servicing while at the same time permit operation from a clear and level space.
- The pedestrian push button location should not interfere with the use of the curb ramp or the sidewalk.
- If a push button cannot be practically located within the recommended area, consider moving it back and adjusting the pedestrian crossing time.
- Do not place the push button pole in the pedestrian access route.
- A firm, stable, slip resistant surface must be provided to allow for a forward or side reach to the pedestrian push button from a wheelchair.
- Pedestrian push buttons should not be placed adjacent to the running slope of a curb ramp.
- Pedestrian push buttons should be located on the side of the pole from which the pedestrian accesses the button. Pedestrians should not have to reach around the pole to access the button.



Use this link to view further information on CDOT's Pedestrian Crossing Guidelines: <https://www.codot.gov/safety/traffic-safety/assets/documents/cdot-pedestrian-crossing-guidelines-2021.pdf>

Figure 12-25 Pedestrian Push Button Reach Ranges

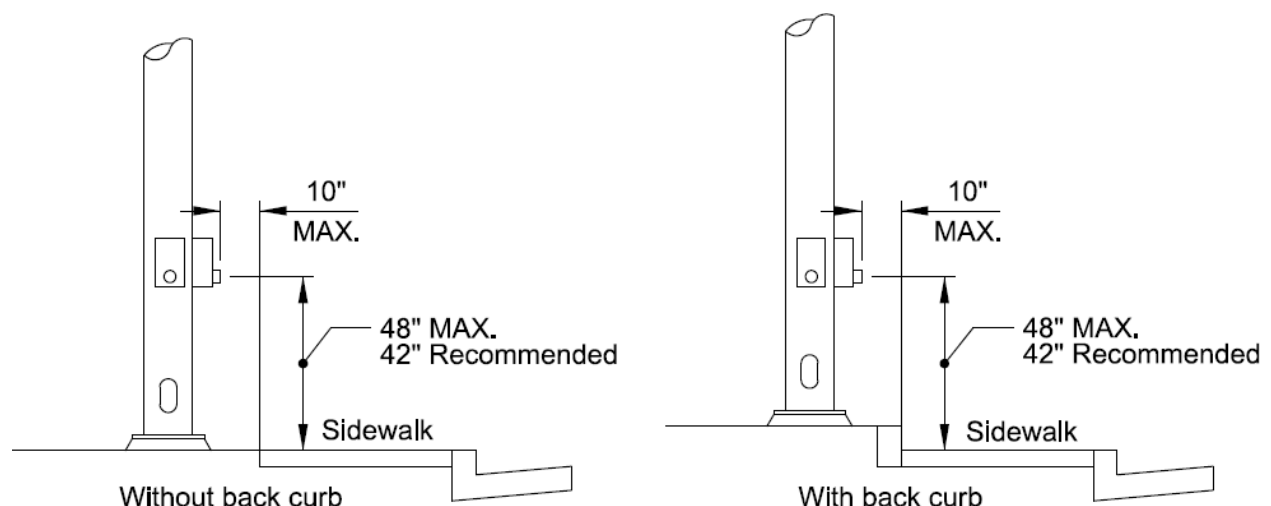
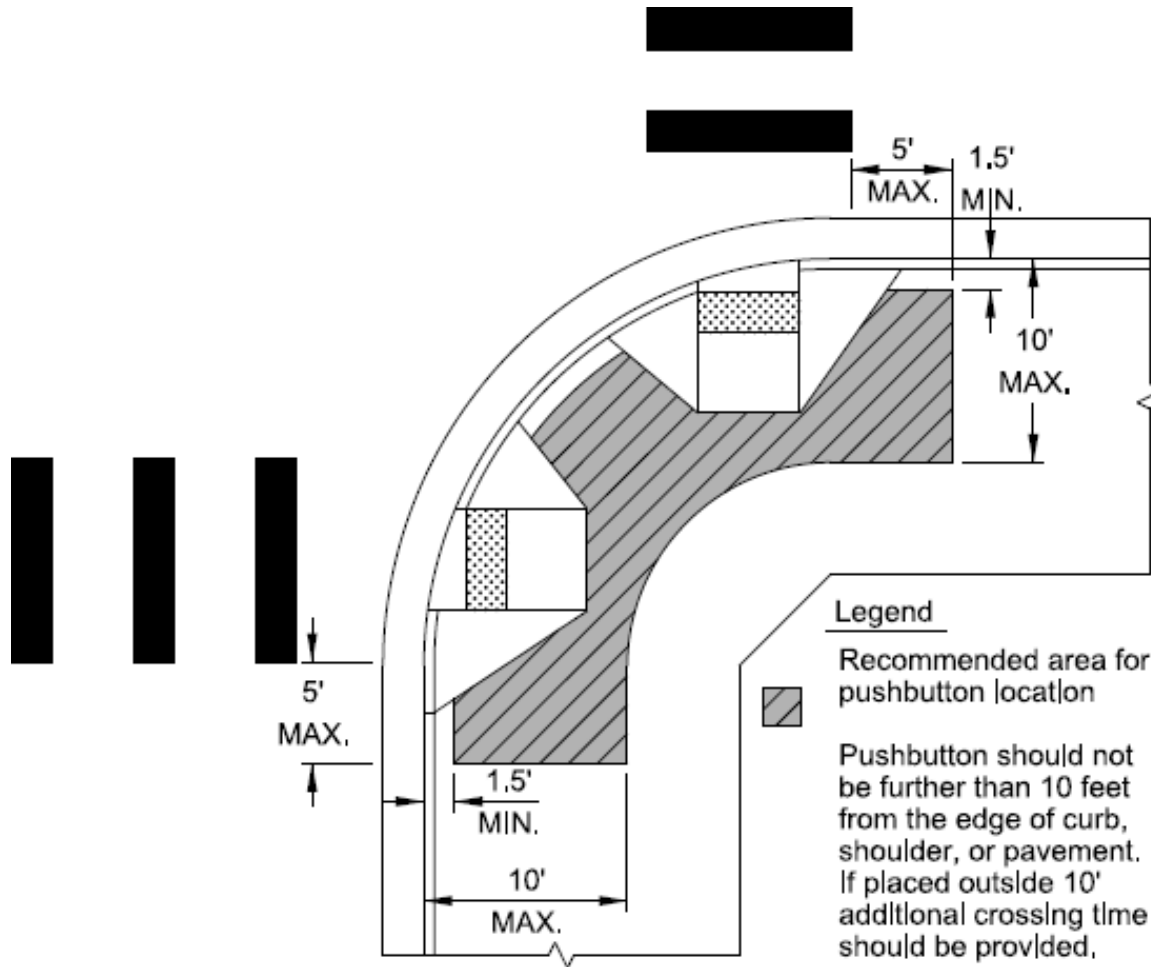



Figure 12-26 Pedestrian Push Button Placement



**12.9 Pedestrian Ramp, Landings & Handrails – PROWAG (R407 “RAMPS”)**

Pedestrian ramps (not to be confused with curb ramps) that traverse changes of elevation should use a running slope between 5.0% and 8.33%. Where possible, the flattest running slope should be used to accommodate the widest possible range of users. Wheelchair users with disabilities affecting their arms, or individuals with low stamina, can have difficulties using pedestrian ramps. For this reason, level landing areas are provided at regular intervals on pedestrian ramps. The vertical rise of any ramp run shall not exceed 30 inches without a level landing space. Ramps shall have level landing spaces at both the top and the bottom of each ramp run. Landing spaces should be 5 feet in length and match the width of the ramp. If the landing space is located at a 90-degree turn in the ramp it should have a minimum dimension of 5 feet by 5 feet.

Any ramp with a vertical rise greater than 6 inches shall provide handrails. For requirements for pedestrian handrails refer to R409 in PROWAG.





Figure 12-27 Pedestrian Ramp Elements

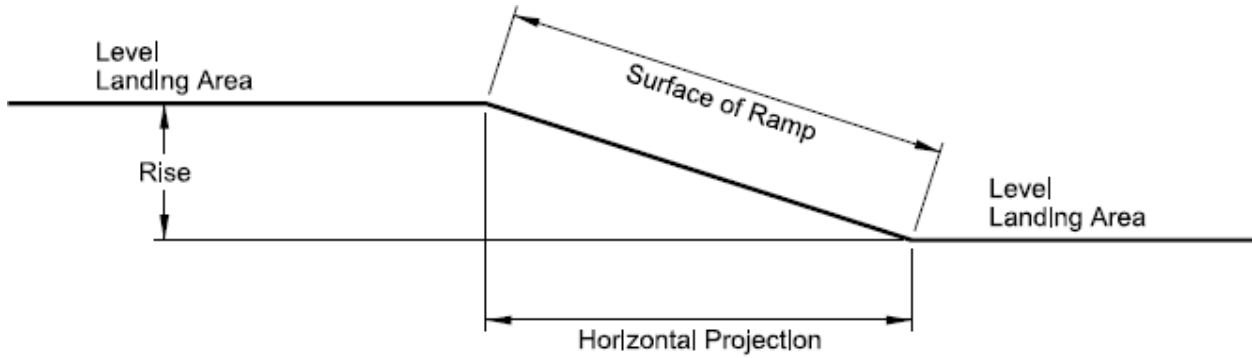

Figure 12-28 Pedestrian Ramp Turning Space Requirements

