

Colorado Procedure 37-19

Standard Test Method for

Plastic Fines in Graded Aggregates and Soils by Sand Equivalent Test

(This test method is based upon AASHTO T 176-02. AASHTO T 176-02 or any subsequent revision may not be used in place of this procedure.)

1. SCOPE

1.1. This test is for the determination of the proportion of fine dust or claylike material in graded aggregates and soils.

2. APPARATUS

2.1 A graduated plastic cylinder, rubber stopper, irrigator tube, weighted foot assembly and siphon assembly, all conforming to their respective specifications and dimensions shown in Figure 37-1. Fit the siphon assembly to a 1 gallon bottle of working calcium chloride solution placed on a shelf 36 +/- 1 inch above the working surface. In lieu of the specified 1 gallon bottle, a glass or plastic vat having a larger capacity may be used provided the liquid level of the working solution is maintained between 36 to 46 inches above the work surface.

2.2 A tinned measure, having a capacity of 85 +/- 5 mL (3 oz), approximately 57 mm (2.25 in) in diameter.

2.3 A wide-mouth funnel approximately 4 inches in diameter at the mouth.

2.4 A clock or watch reading in minutes and seconds.

2.5 A mechanical shaker, powered by an electric motor, having a throw of 8.00 +/- 0.04 in. (203.2 +/- 1.0mm) and operating at 175 +/- 2 cycles per minute. The shaker shall be securely affixed to a firm and level mount.

2.6 Stock Solution – The materials listed in Subsections 2.6.1, 2.6.2, or 2.6.3 may be used to prepare the stock solution. A fourth alternative is not to use any biocide provided the time of storage of stock solution is not sufficient to promote the growth of fungi.

2.6.1 Stock solution with formaldehyde:

2.6.1.1 Anhydrous Calcium Chloride, 454g of technical grade.

2.6.1.2 USP Glycerin, 2050g (1640 mL).

2.6.1.3 Formaldehyde, (40 volume percent solution) 47g (45 mL).

2.6.1.4 Dissolve the 454g of calcium chloride in 1.89 L of distilled water. Cool and filter it through ready pleated rapid filtering paper. Add the 2050g of glycerin and the 47g of formaldehyde to the filtered solution, mix well and dilute to 3.78 L.

2.6.2 Stock solution with glutaraldehyde:

2.6.2.1 Calcium Chloride Dihydrate, 577g of A.C.S. grade.

2.6.2.2 USP Glycerin, 2050g (1640 mL).

2.6.2.3 1.5-Pentanedial (Glutaraldehyde), 50 percent solution in water 59g (53 mL).

NOTE 1: 1.5-pentanedial, also known as glutaraldehyde, glutaric dialdehyde, and trade name UCARCIDE 250, may be obtained as Glutaraldehyde Solution 50 percent.

2.6.2.4 Dissolve the 577g of calcium chloride dihydrate in 1.89 L of distilled water. Cool and add the 2050g of glycerin and the 59g of glutaraldehyde to the solution, mix well and dilute to 3.78 L.

2.6.3 Stock solution with Kathon CG/ICP:

2.6.3.1 Calcium Chloride Dihydrate, 577g of A.C.S. grade.

2.6.3.2 USP Glycerin, 2050g (1640 mL).

2.6.3.3 Kathon CG/ICP, 563g (53 mL).

2.6.3.4 Dissolve the 577g of calcium chloride dihydrate in 1.89 L of distilled water. Cool and

add the 2050g of glycerin and the 63g of Kathon CG/ICP to the solution, mix well and dilute to 3.78 L.

2.7. Working calcium chloride solution: Prepare the working calcium chloride solution by diluting 85 ± 5 mL of the stock calcium chloride solution with water until it reaches a total volume of 3.8 L. Thoroughly mix solution by filling the bottle with approximately 2 L of water. Add the stock solution and agitate vigorously for 1 to 2 minutes. Add the remainder of the water and repeat the agitation process. Use distilled or demineralized water for the preparation of the working solution. Discard working solutions more than 30 days old.

2.8 A straightedge or spatula, suitable for striking off the excess soil from the tin measure.

2.9. A thermostatically controlled drying oven capable of providing a temperature up to 60°C (140°F).

2.10. A non-absorbent plastic quartering or splitting sheet or non-absorbent pan.

2.11 Optional handle for irrigation tube – A 25-mm diameter wooden dowel to aid in pushing the irrigation tube into firm materials.

3. CONTROL

3.1. The temperature of the working solution should be maintained at $22^{\circ}\text{C} \pm 3^{\circ}$ ($72^{\circ}\text{F} \pm 5^{\circ}$) during the performance of the test. If field conditions prevent the maintenance of the temperature range frequent samples should be submitted to a laboratory where proper temperature can be maintained. A correction curve may be established for each material being tested where proper temperature control is not possible. No general correction curve should be used on several materials even within a narrow range of values. Samples that meet the minimums and equivalent requirements at a solution temperature below the recommended range need not be subject to reference testing.

4. SAMPLE PREPARATION

4.1. All materials being tested by this method shall pass the 4.75 mm (#4) sieve. Pulverize all aggregations of fine grained soil material to pass the 4.75 mm (#4) sieve and clean all fines from the particles retained on the 4.75 mm (#4) sieve.

All aggregations passing the 4.75 mm (#4) sieve shall be tested.

4.2. Split or quarter to yield a representative sample of at least 1500g of material passing the 4.75 mm (#4) sieve. Extreme care should be used to ensure the test sample is truly representative of the original sample.

4.3. Dry the sample to constant mass at a temperature not to exceed 60°C (140°F).

4.3.1. Weigh the dried sample to the nearest 0.1g. Thoroughly mix $3 \pm 1\%$ moisture into the material, cover and allow tempering for 45 ± 15 minutes.

4.3.2. After the tempering period, place the material on the splitting sheet or pan. Mix the sample until it appears homogeneous forming a pile. Using the splitting sheet, mixing can be accomplished by pulling a corner of the sheet diagonally across the material toward the opposite corner causing the material to be rolled. Continue pulling the corners of the sheet across until the sample appears homogeneous. Finish mixing with the sample in a pile near the center of the splitting sheet. Using the pan, mixing can be accomplished by turning the entire sample over at least 3 times. Upon the final turning, form the material in a conical pile by depositing each scoopful on top of the preceding one.

4.3.3. Fill three 85 ml tins by pushing them through the base of the pile while exerting pressure with the hand on the opposite side of the pile. Use enough pressure to cause the tins to fill to overflowing. Press the material firmly into the tins with the palm of the hand allowing the maximum amount of material to be placed in the tins. Using the spatula, strike off the excess material above the top of the tins.

4.3.4 Each of the three tins prepared in Subsection 4.3.3 is an individual test sample.

5. PROCEDURE

5.1. Siphon 101.6 ± 2.5 mm (4.0 ± 0.1 in.) of the working solution into the graduated cylinder. Pour a prepared test sample into a graduated cylinder using the funnel to avoid spillage. Tap the bottom of the cylinder sharply with the heel of the hand several times to release air bubbles and promote thorough wetting of the sample.

5.2. Allow the sample to stand undisturbed for 10 +/- 1 minute. After the 10 minute soaking period, stopper the cylinder and loosen the material from the bottom of the cylinder by partially inverting the cylinder and shaking simultaneously.

5.3. After loosening the material place the cylinder into the shaker, set the timer and allow the machine to shake the sample for 45 +/- 1 second.

5.4. Following the shaking period place the cylinder upright on the work surface and remove the stopper.

5.5. Insert the irrigator tube in the cylinder and rinse the material from the cylinder walls as the irrigator is lowered. Force the irrigator through the material to the bottom of the cylinder by using a gentle stabbing and twisting motion while the working solution is flowing from the irrigator tip. Continue to apply the stabbing and twisting action of the irrigator to suspend the fine material until the level nears the 381mm (15 in.) mark. As the level nears the 381 mm (15 in.) mark, without stopping the flow, slowly raise the irrigator as to maintain the 381mm (15 in.) level. Adjust the final level to 381mm (15 in.). The final level, as judged by the bottom of the meniscus, shall be between the top two graduations of the cylinder but not above the 381mm (15 in.) mark.

NOTE 2: On certain soils, particularly crushed materials, the stabbing action may not be possible. For such materials, the irrigation method is as follows: Continue to apply the twisting action as the irrigator tube is slowly withdrawn. As the irrigator tube is withdrawn, it is essential that as many of the fines be flushed upward until the level reaches the 381mm (15in.) level.

5.6. Allow the cylinder and contents to stand undisturbed for 20 minutes +/- 15 seconds. Start timing immediately after withdrawing the irrigator tube.

5.7. At the end of the 20 minute settling period, read and record the top of the clay layer. This is referred to as the "clay reading". If no clear line is formed at the end of the 20 minute period, allow the sample to stand undisturbed until a reading can be obtained. Once the reading can be made, record the clay reading and the total sedimentation time.

If the sedimentation time exceeds 30 minutes, retest the material using 3 individual samples of the same material. Read and record the clay reading of the sample that takes the least amount of time to form a clear line. Do not record the readings from the other two samples.

5.8. Immediately after taking the clay reading, gently lower the weighted foot assembly into the cylinder. Do not allow the indicator to hit the mouth of the cylinder as it is lowered. As the foot comes to rest on the sand, tip the assembly toward the graduations until the indicator touches the inside of the cylinder. Subtract 254 mm (10 in.) from the level indicated by the top edge of the indicator and record this value as the sand reading.

5.9. If the clay or sand reading falls between the graduations, record the next higher graduation line as your reading. For example: The indicator level is 6.22. The recorded level would be 6.3.

5.10 Repeat Subsections 5.1 to 5.9 for each of the three samples prepared in Subsections 4.3.3.

6. CALCULATIONS

6.1. Calculate the sand equivalent for each of the three test samples to the nearest 0.1 using the following formula:

$$SE = \frac{\text{Sand Reading} \times 100}{\text{Clay Reading}}$$

If the sand equivalent is not a whole number, report as the next higher whole number.

For example:

$$SE = 3.3 \times 100 / 8 = 41.25$$

Report as 42

6.2. Average the three SE values obtained in 6.1 to the nearest 0.1. If the average sand equivalent is not a whole number, report as the next higher whole number.

For example:

$$(42 + 44 + 41) / 3 = 42.3$$

Report as 43

7. PRECAUTIONS

7.1. When performing this test the work surface must be free of vibration. During the sedimentation period vibration may cause the suspended material to settle at a greater rate than normal, resulting in false readings. The shaker shall not be mounted on the same surface as the cylinders during the sedimentation period.

7.2. Do not expose the cylinders to direct sunlight any more than necessary.

7.3. On occasion organic growth in the working solution container and tubing will need to be removed. Growth can be seen as a slimy substance in the solution or as grayish black deposits on the sides of the container and in the tubing. To remove the growth prepare a solution of sodium hypochlorite³ and water in equal amounts. Fill the container and allow about a liter to flow through the siphon assembly and irrigator tube. Refill the container and allow to stand overnight. After soaking allow the solution to flow out through the siphon assembly and irrigator tube. Remove the siphon assembly and rinse both the container and assembly with clear water. Allow water to flow through the assembly and irrigator tube to rinse the solvent from the inside of the tubing.

7.4. Occasionally the holes on the tip of the irrigator tube can become clogged. This can be checked easily while filling the cylinder to the initial amount as in Subsection 5.1. If the particle can not be removed by any other method, carefully use a pin or small wire to dislodge the particle, taking care to not enlarge the opening.

7.5. Upon receipt of a new weighted foot assembly and before placing it in service, measure and adjust the height of the indicator to 256.5 mm (10.1 in.).

8. PRECISIONS AND BIAS

8.1 *Multi-laboratory Precision* – Using CDOT IA test results; the standard deviation of the difference between values obtained on the same sample from different laboratories is 2.3 (d2s). Therefore, the results of two properly conducted tests from different laboratories on similar material should not differ by more than 5.0 with a 95% confidence limit.

8.2 *Bias* – The procedure in this test method has no bias because the value of sand equivalent is defined only in terms of the test method.

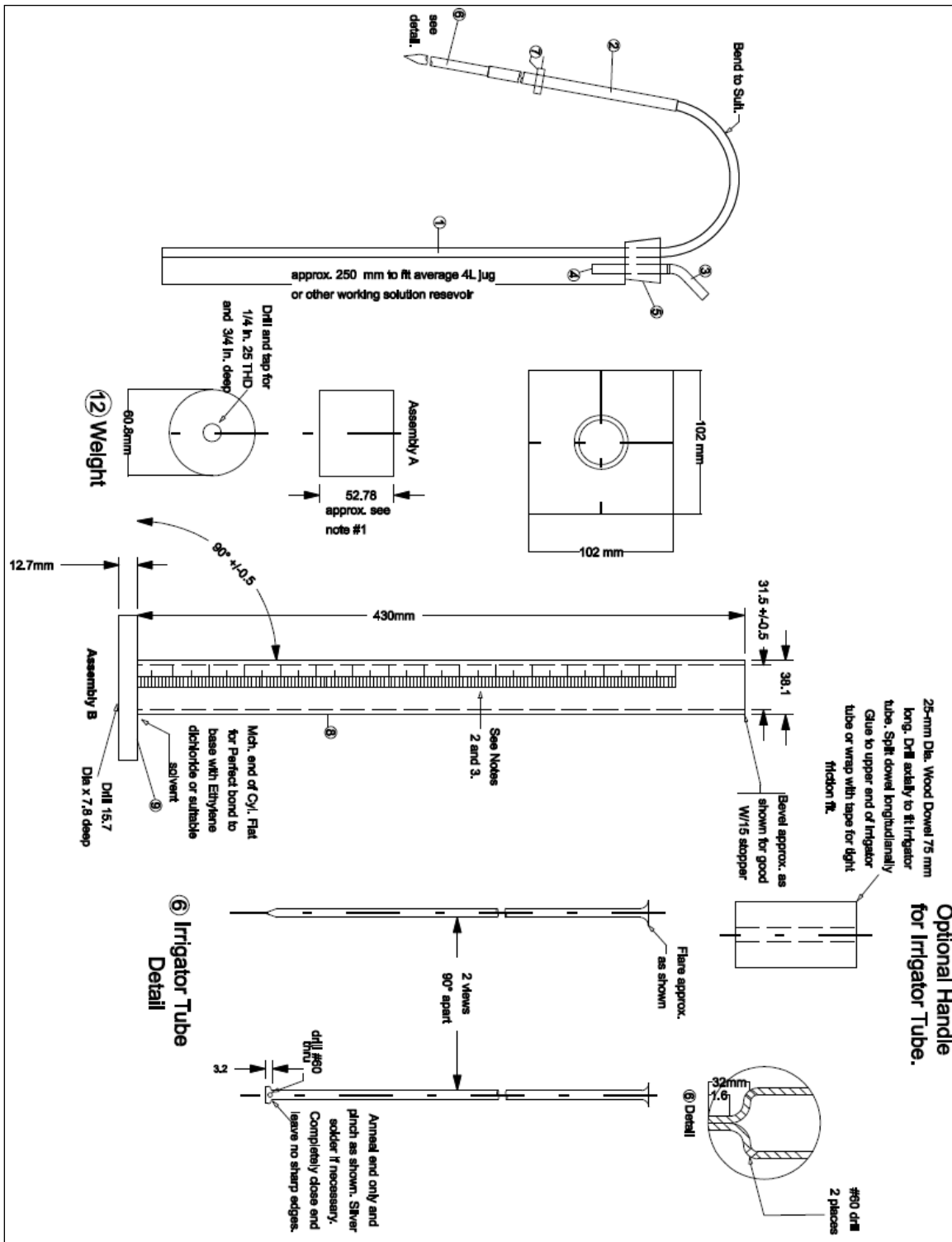

FIGURE 37-1

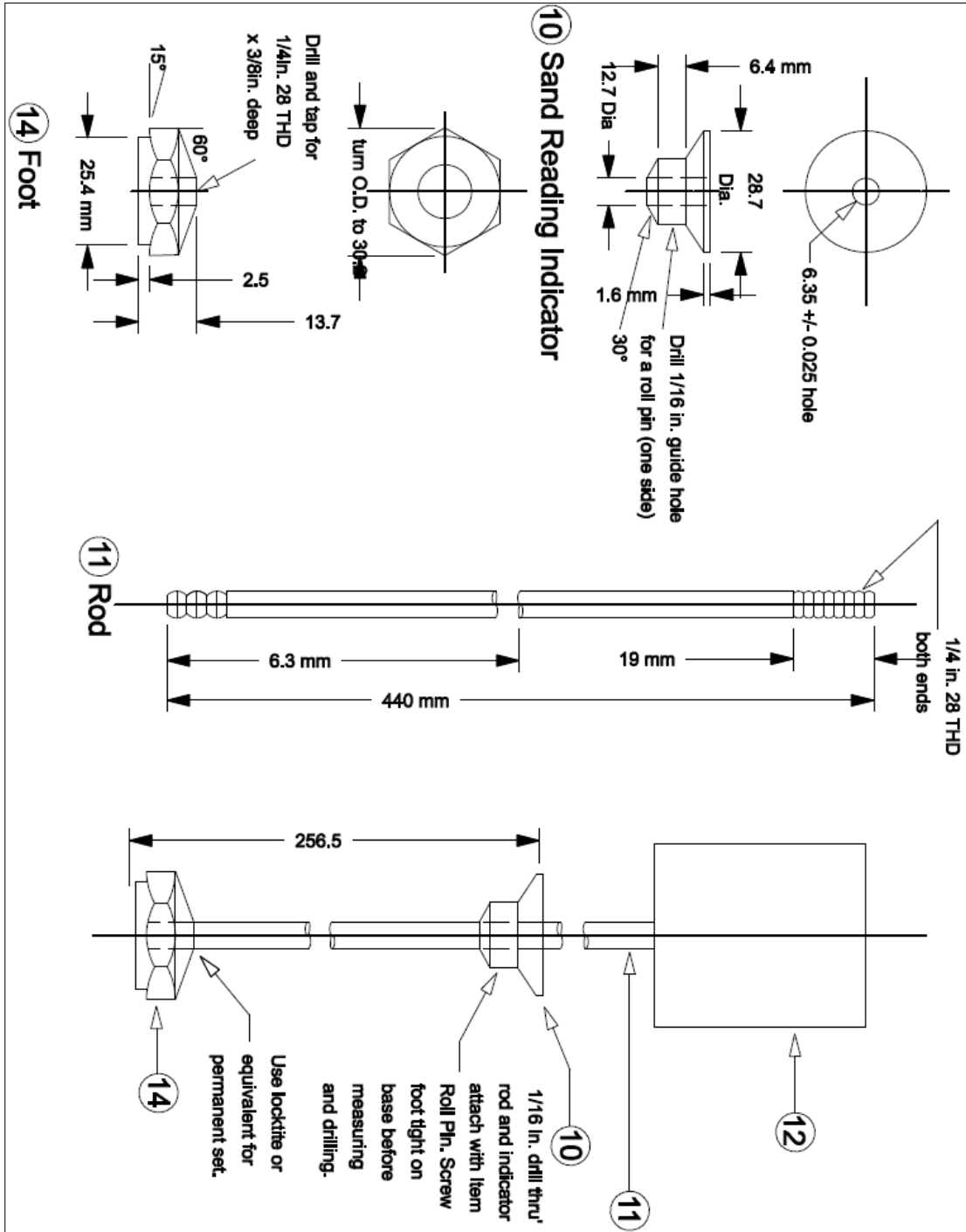

FIGURE 37-1 (Continued)

Assembly	No. Reg.	Description	Stock Size (mm)	Material	Heat Treatment
A Siphon Assembly					
	1	Siphon Tube	6.4 dia. x 400	Copper Tube	
	2	Siphon Hose	4.8 I.D. x 200	Rubber Tube	
	3	Blow Hose	4.8 I.D. x 50.8	Rubber Tube	
	4	Blow Tube	6.4 dia. x 50.8	Copper Tube	
	5	Two-Hole Stopper	No. 6	Rubber	
	6	Irrigator Tube	6.4 O.D. 0.89 Wall x 500	Stainless Tube, Type 316	
	7	Clamp	Pinchcock, Day, BKH No. 21730 or Equivalent		
B Graduate Assembly					
	8	Tube	38.1 O.D. x 430	Trans Acrylic Plastic	
	9	Base	12.7 x 102 x 102	Trans Acrylic Plastic	
C Weighted Foot Assembly					
	10	Sand Reading Indicator	6.4 dia x 14.9	Nylon 101 Type 66	Annealed
	11	Rod	6.4 dia x 438.2	Brass	
	12	Weight	50.8 dia x 52.78	C.R.SH	
	13	Roll Pin	0.16 dia x 12.7	Steel	
	14	Foot	0.16 Hex x 13.7	Brass	
	15	Solid Stopper	No. 7	Rubber	

- Notes:
- 1 "C" Mounted Foot Assembly to Weight 1000+/- 5g
 - 2 Graduations on graduate to be 2.54 mm apart and every tenth mark to be numerically designated as shown. Every fifth line should be approximately 9.5 mm long. All other lines should be approximately 5.5 mm long. Depth to be 0.4 mm. Width to be 0.8 mm across the top.
 - 3 Accuracy of scale to be +/- 0.25 mm per 2.5 mm. Error at any point on scale to be +/- 0.75 mm of true distance to zero
 - 4 Glass or stainless steel may be substituted as a material type for the copper siphon and blow tubing

FIGURE 37-1 (Continued)

{This page was intentionally left blank.}