

## Colorado Procedure – Laboratory 4301-18

### *Standard Method for*

## **SURFACE ABRASION RESISTANCE OF POLYESTER CONCRETE**

### **1. SCOPE**

- 1.1 This surface abrasion test method describes the procedure used to measure the ability of a polyester concrete specimen to resist surface abrasion by impact of steel balls in the presence of water.

### **2. APPARATUS**

- 2.1 A mechanical shaker capable of agitating a mold assembly containing the test specimen, water, and steel balls, in a vertical direction at 1,200 cycles/min +/- 10 cycles/minute with a 1 in. stroke.
- 2.2 One steel test mold, 4 in. diameter by 5 in. high, fitted with a watertight base and cover. A 1/8 in. steel ring, triangular in cross-section, and inserted to form a lip, encircles the mold interior 2 in. above the bottom and combines with the base to hold the sample in place and protect the vulnerable edges of the specimen. See Figure 1.
- 2.3 Eight chrome steel balls, 13/32 in. diameter and weighing 4.5 g ± 0.3 g each. Total mass of the 8 balls shall be between 32 g and 38 g.
- 2.4 One 200 mL graduated cylinder.
- 2.5 A scale with a capacity of 1000 g and accuracy of ± 0.1 g.
- 2.6 ½ in. × 1 in. × 6 in. rubber tamper

### **3. SPECIMEN FABRICATION**

- 3.1 Temperature of the air in the vicinity of the mixing area, the dry materials, molds, base plates, and mixing bowl shall be maintained from 68 to 77°F.
- 3.2 Preparation of Materials. Care must be taken to avoid contamination of individual components. The hazards of each individual component must be recognized.
- 3.2.1 Materials shall be brought to a uniform temperature in the range of 68 to 77°F prior to mixing.
- 3.2.2 The moisture content of the aggregate shall not exceed one half of the absorption of the aggregate. The aggregate shall be 100 % passing the ½ in. sieve. Care should be taken to avoid segregation of aggregate.

- 3.3 Mix the polyester concrete as specified by the manufacturer in the electric mixer or by hand in a batch of such size to yield 10 % excess after molding test specimens. Hand-mixing procedures are not applicable to air entrained mixes or mixes with no measurable slump. Follow the manufacturer's recommendations as to the order of addition and mixing times. Materials shall be mixed thoroughly in the time allotted.
- 3.4 Begin molding the specimens within 1 min after completion of the mixing.
- 3.5 Specimen Mold Preparation. Cover the interior and exterior of the assembled molds with a mixture of one part paste wax dissolved in 2 to 3 parts toluene and allow to dry before using.
- 3.6 Mix the materials as specified by the material supplier in an electric mixer, drum or open tub type, in a batch of such size to yield 5 % excess after molding test specimens.
- 3.7 Place a layer of the batched material in each compartment of the mold approximately 1 in. deep.
- 3.8 Tamp the batch in each compartment 25 times with a ½ in. × 1 in. × 6 in. rubber tamper in a spiral motion, making sure all edges are tamped. Tamping shall be completed in each compartment before going on to the next.
- 3.9 When the tamping of the first layer in all compartments is completed, jig the mold to remove entrapped air along the sides.
- 3.10 Fill the compartments and tamp as specified for the first layer. Upon completion, the material should extend slightly above the top of the molds.
- 3.11 With a trowel, force the batch downward into the mold. When compaction is completed, strike off the top surface and finish to a smooth surface with a steel straightedge.
- 3.12 The specimens shall be soaked in water for a minimum of 2 hours prior to testing.

#### **4. PROCEDURE**

- 4.1 Surface dry the specimen, weigh, and record mass to the nearest gram.
- 4.2 Place specimen in the test mold with the surface to be tested facing up. Place the mold with specimen on the test mold base and add 8 steel balls and 200 mL of water. Attach the cover and clamp the assembly to the mechanical shaker.
- 4.3 Agitate the assembly at 1,200 cycles/min ± 10 cycles/min for 3 min ± 5 s and remove from the mechanical shaker.
- 4.4 Remove the specimen from the test mold. Flush off the abraded material, dry the surface, weigh, and record the mass to the nearest gram.

**5. CALCULATIONS**

- 5.1 The abrasion loss in grams is calculated by subtracting the mass of the saturated surface dry specimen after the test from the mass of the surface dry specimen before test.

**6. REPORT**

- 6.1 Report the amount of abrasion loss in grams. The age of the concrete shall be included in the report.

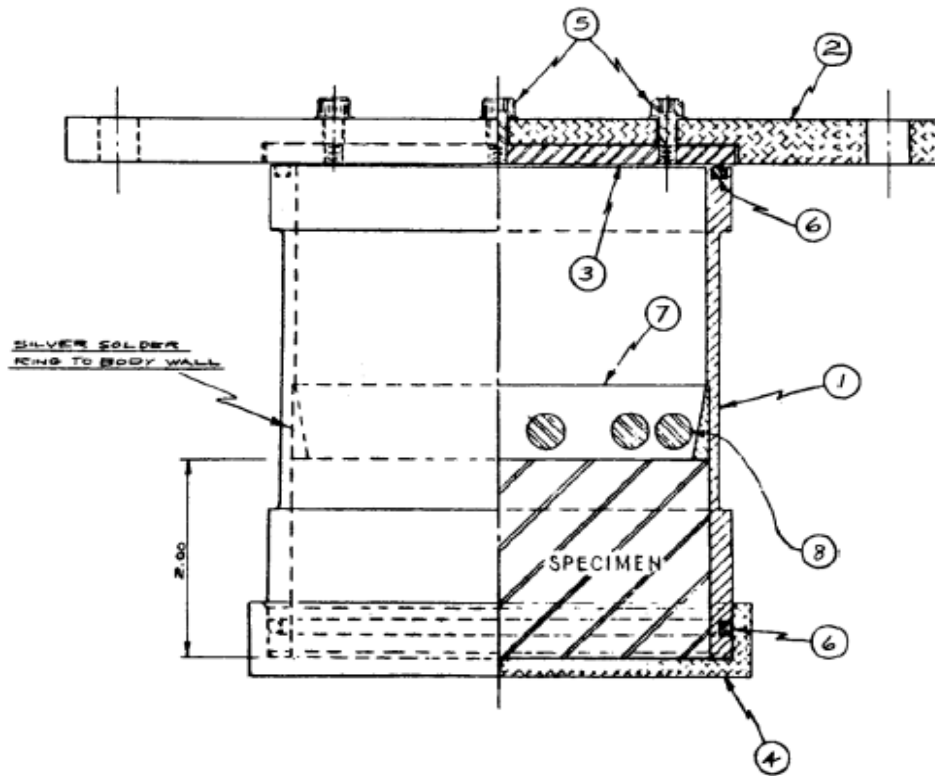

LIST OF MATERIAL					
8	8	Ball Bearings	18/32 inch dia., 4.5 g, Steel		
1	7	Retaining Ring	4140 Steel		
2	6	"O" Ring	4 3/16 in. ID x 4 5/16 in. OD x 1/8 in. dia. Neoprene		
4	5	Cap Screws	10-32NF Socket, Filister HD		
1	4	Base	Alum		
1	3	Wear Plate	4140 Steel		
1	2	Cover	Alum		
1	1	Body	Mild Steel		
No. Req.	Part No.	Description	Stock Size	Material	Remarks

Figure 1