

- GENERAL NOTES**
1. SINCE ALL PIPE ENTRIES INTO THE BASE ARE VARIABLE, THE DIMENSIONS SHOWN ARE TYPICAL. ACTUAL DIMENSIONS AND QUANTITIES FOR CONCRETE AND REINFORCEMENT SHALL BE AS REQUIRED IN THE WORK.
 2. THE PRECAST FLAT TOP MAY BE USED ON ANY MANHOLE. THE ECCENTRIC CONE MAY BE USED WHEN THE MANHOLE "H" HEIGHT IS AT LEAST 8 FT.
 3. THE MANHOLE RING FRAME SHALL BE SET IN A BED OF GROUT. THE FRAME SHALL BE SURROUNDED WITH A CEMENT GROUT IN UNPAVED AREA, OR A CONCRETE COLLAR IN PAVED AREA. SEE DETAILS ON SHEETS 2 AND 3.
 4. DESIGN OF BOX BASE IS BASED ON STRAIGHT RUNS OF PIPE OR CHANGE IN DIRECTION OF LESS THAN 45°. SPECIAL DESIGN IS REQUIRED FOR 45° OR GREATER.
 5. PRECAST MANHOLES AND REINFORCEMENT SHALL CONFORM TO AASHTO M 199 (ASTM C 478).
 6. CAST-IN-PLACE MANHOLES SHALL BE CLASS B CONCRETE.
 7. STEPS ARE REQUIRED WHEN THE MANHOLE DEPTH EXCEEDS 3 FT.-6 IN. AND SHALL CONFORM TO AASHTO M 199.
 8. ALL REINFORCING STEEL SHALL BE GRADE 60 AND EPOXY COATED. VERTICAL STEEL SHALL BE PLACED AT CENTERLINE OF WALL. ALL BARS SHALL HAVE A 2 IN. MINIMUM CLEARANCE.
 9. ALL PIPE ENTRIES INTO THE BASE OF MANHOLE SHALL BE CONNECTED BY OPEN CHANNELIZATION ADJUSTED FOR PIPE SIZE, SHAPE, SLOPE, AND DIRECTION OF FLOW. DETAILS SHOWN ARE TYPICAL FOR INSTALLATIONS WITH ALL INVERTS OF SAME RELATIVE ELEVATION. FOR EXCESSIVE ELEVATION DIFFERENCE BETWEEN INVERTS, SPECIAL BASE/CHANNEL DETAILS WILL BE SHOWN ON THE PLANS.
 10. FLOW CHANNELS AND INVERTS SHALL BE FORMED BY SHAPING WITH CLASS B CONCRETE OR APPROVED GROUT.
 11. STUB-OUTS SHALL EXTEND 2 FT. MINIMUM BEYOND OUTSIDE WALL SURFACE OF MANHOLE AND BE SATISFACTORILY PLUGGED.
 12. THE SLOPE OF THE MANHOLE COVER SHALL MATCH THE ROADWAY PROFILE AND CROSS SLOPE.

MARK	SIZE	TYPE	WT. #/FT.	BARS	I.D.					FORMULAS	
					54"	60"	66"	72"	84"		96"
401	4	I	0.668	{ NO. REQ'D. LENGTH WEIGHT #	18 8'-1" 97.2	18 8'-8" 104.2	18 9'-3" 111.2	18 9'-10" 118.2	18 11'-0" 132.3	18 12'-2" 146.3	401 BAR LENGTH = 32" + 2W + I.D.
402	4	III	0.668	{ NO. REQ'D. LENGTH WEIGHT #	5 5'-5" 18.1	5 6'-0" 20.0	5 6'-7" 22.0	5 7'-2" 23.9	5 8'-4" 27.8	5 9'-6" 31.7	402 BAR LENGTH = I.D. + 2W
501	5	I	1.043	{ NO. REQ'D. LENGTH WEIGHT #	17 7'-5" 131.5	17 8'-0" 141.8	17 8'-7" 152.2	17 9'-2" 162.5	17 10'-4" 183.2	17 11'-6" 203.9	501 BAR LENGTH = 24" + I.D. + 2W
502	5	I	1.043	{ NO. REQ'D. LENGTH WEIGHT #	22 5'-0" 114.7	23 5'-0" 119.9	25 5'-0" 130.4	26 5'-0" 135.6	29 5'-0" 151.2	32 5'-0" 166.9	502 NUMBER BARS REQ'D. = 3 + ((24 + I.D. + 2W) / 5) + 1
503	5	II	1.043	{ NO. REQ'D. LENGTH WEIGHT #	16 12'-10" 214.2	16 13'-5" 223.9	18 14'-0" 262.8	18 14'-7" 273.8	20 15'-9" 328.5	24 16'-11" 423.5	503 NUMBER BARS REQ'D. = 2 * ((13 + I.D. + 2W) / 12) + 1 BAR LENGTH = 4'-9" + 2(16 + W + I.D./2)
504	5	I	1.043	{ NO. REQ'D. LENGTH WEIGHT #	12 8'-1" 101.2	14 8'-8" 126.6	14 9'-3" 135.1	16 9'-10" 164.1	18 11'-0" 206.5	20 12'-2" 253.8	504 NUMBER BARS REQ'D. = 2 * ((2W + I.D. - 4) / 12) + 1 BAR LENGTH = 32" + 2W + I.D.
1101	11	I	5.313	{ NO. REQ'D. LENGTH WEIGHT #	4 7'-2" 152.3	4 7'-9" 164.7	4 8'-4" 177.1	4 8'-11" 189.5	4 10'-1" 214.3	4 11'-3" 239.1	1101 BAR LENGTH = 21" + I.D. + 2W
1102	11	I	5.313	{ NO. REQ'D. LENGTH WEIGHT #	4 2'-8" 56.7	4 2'-8" 56.7	4 2'-8" 56.7	4 2'-8" 56.7	4 2'-8" 56.7	4 2'-8" 56.7	BENDING TYPE I STRAIGHT
					3 5'-0" 79.7	3 5'-0" 79.7	3 5'-0" 79.7	3 5'-0" 79.7	3 5'-0" 79.7	TYPE II 16" + W + I.D./2	
					3 5'-0" 79.7	3 5'-0" 79.7	3 5'-0" 79.7	3 5'-0" 79.7	3 5'-0" 79.7		
1103	11	I	5.313	{ NO. REQ'D. LENGTH WEIGHT #	3 5'-0" 79.7	3 5'-0" 79.7	3 5'-0" 79.7	3 5'-0" 79.7	3 5'-0" 79.7		
REINFORCING STEEL TOTAL #					965.6	1,037.5	1,127.2	1,204.0	1,380.2	1,601.6	
CONCRETE - CUBIC YARDS - TOTAL					6.0	6.6	7.3	8.0	9.5	11.1	

NOTE: QUANTITIES ARE BASED ON SAME SIZE PIPE ENTRANCE TO AND EXIT FROM, BASE AND A 4 FT. MANHOLE ENTRANCE INTO TOP SLAB OF BASE.

QUANTITIES FOR CONCRETE MANHOLE BOX BASE

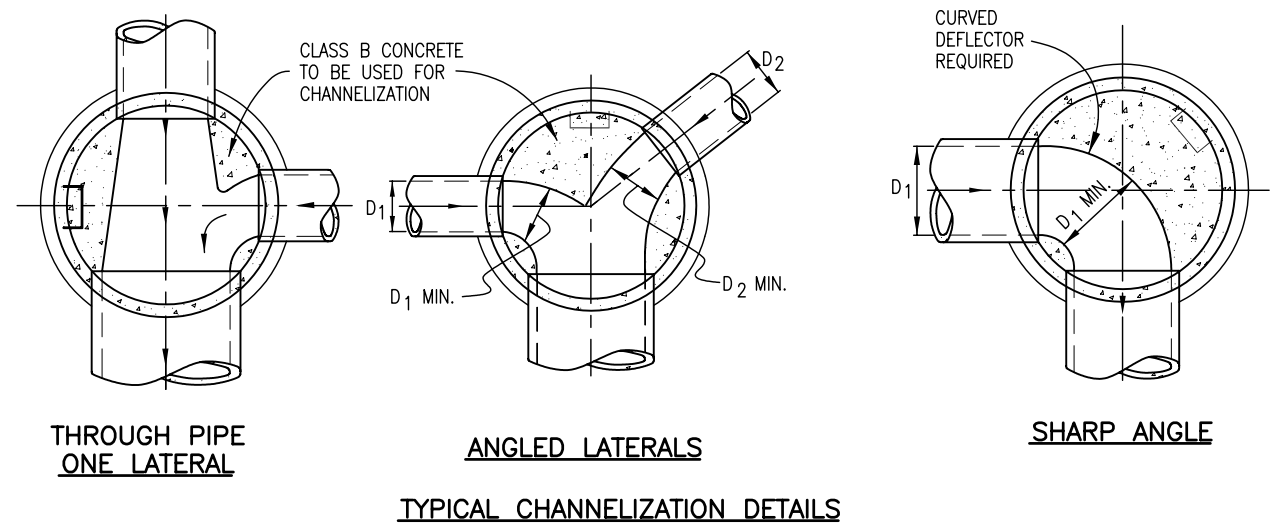

Computer File Information

Creation Date: 07/04/06	Initials: SJR
Last Modification Date: 07/04/06	Initials: LTA
Full Path: www.dot.state.co.us/DesignSupport/	
Drawing File Name: 6040200103.dwg	
CAD Ver.: MicroStation V8	Scale: Not to Scale Units: English

Sheet Revisions

Date:	Comments:
(R-X)	
(R-X)	
(R-X)	
(R-X)	

Colorado Department of Transportation
 4201 East Arkansas Avenue
 Denver, Colorado 80222
 Phone: (303) 757-9083
 Fax: (303) 757-9820
 Project Development Branch SRJ/LTA

Issued By: Project Development Branch on July 04, 2006

STANDARD PLAN NO.
M-604-20
Sheet No. 1 of 3

MANHOLES

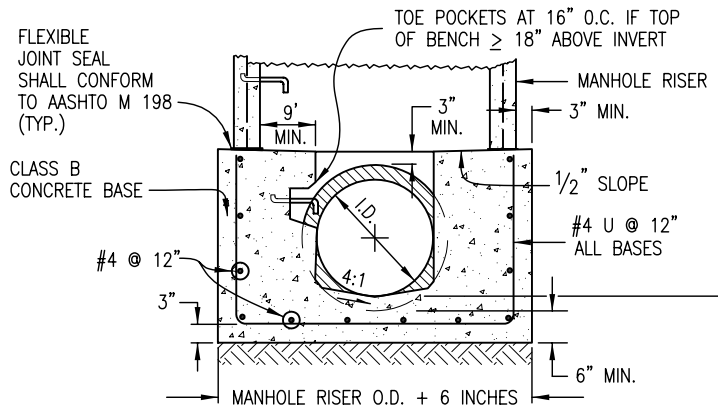

SECTION B-B

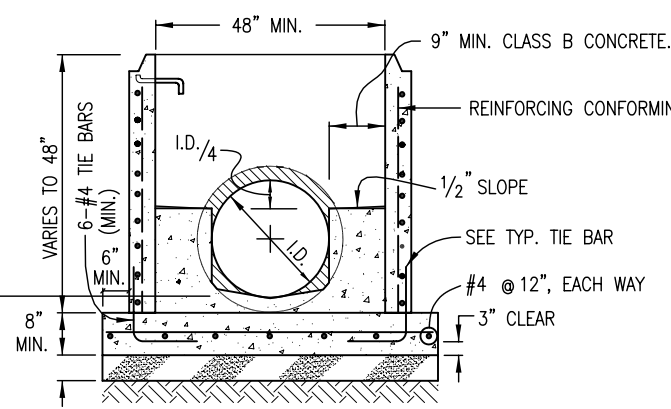

SECTION D-D

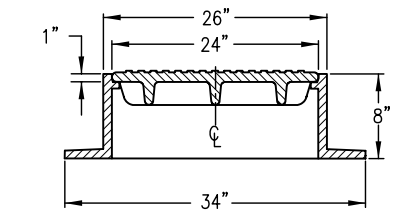
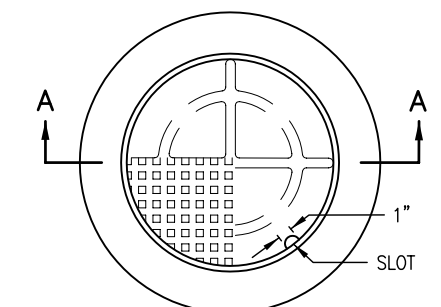
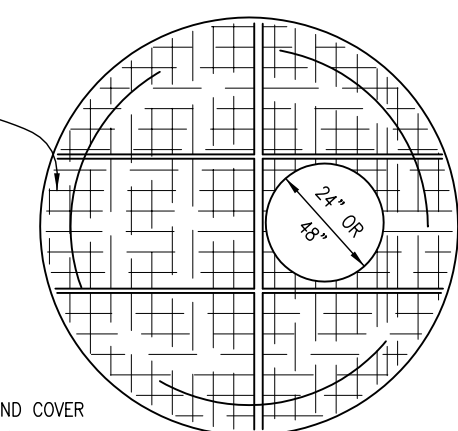

TOTAL WEIGHT: APPROXIMATELY 400 LBS.
SHALL BE GRAY OR DUCTILE CAST IRON IN ACCORDANCE WITH SUBSECTION 712.06.

**SECTION A-A
MANHOLE RING AND COVER**

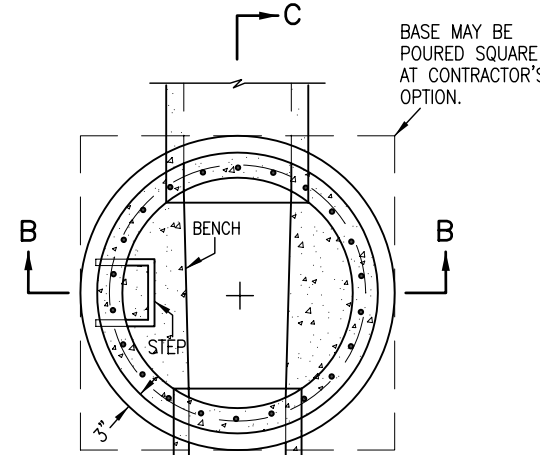

PLAN

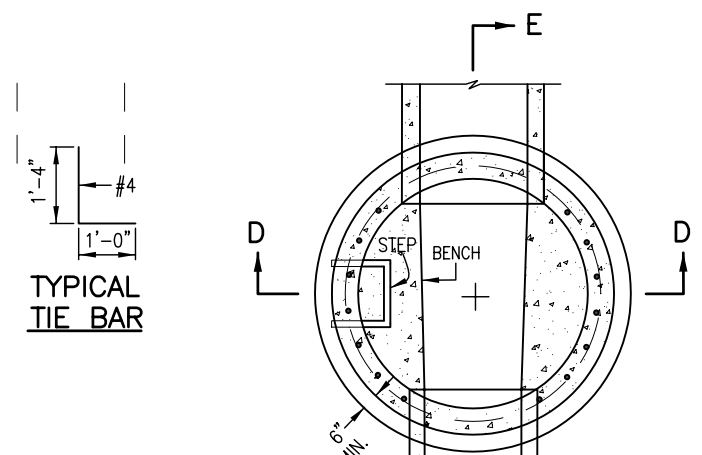

PLAN

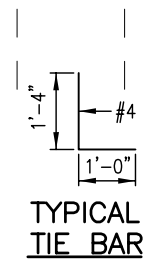

TYPICAL TIE BAR

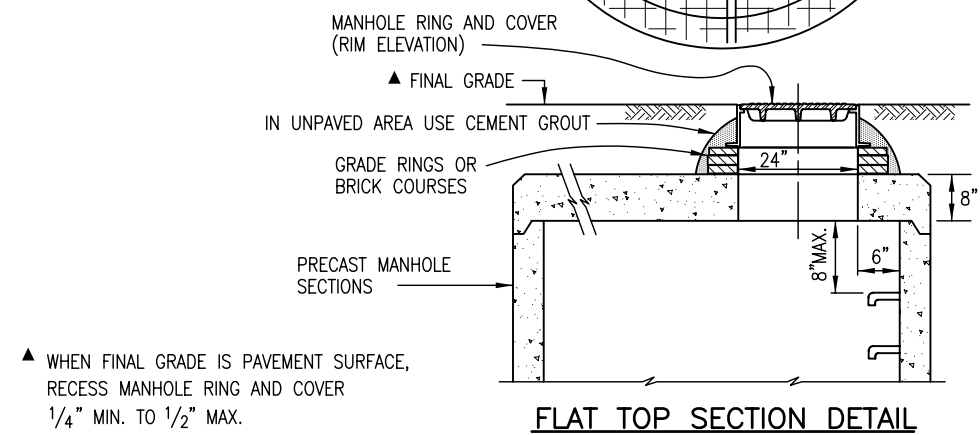

FLAT TOP SECTION DETAIL

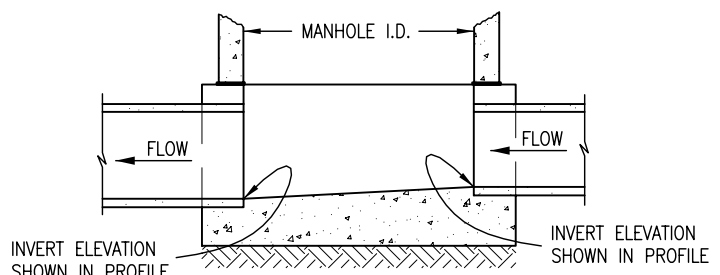

**SECTION C-C
CAST-IN-PLACE SLAB BASE**

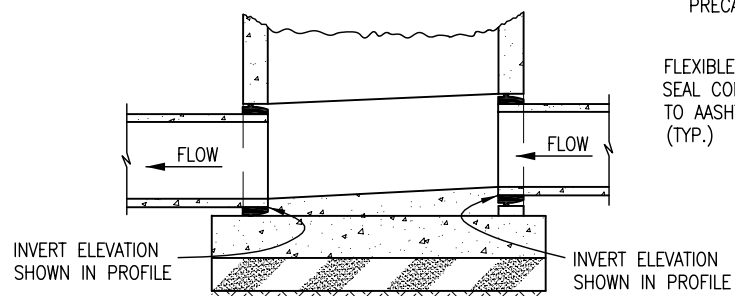

**SECTION E-E
PRECAST SLAB BASE**

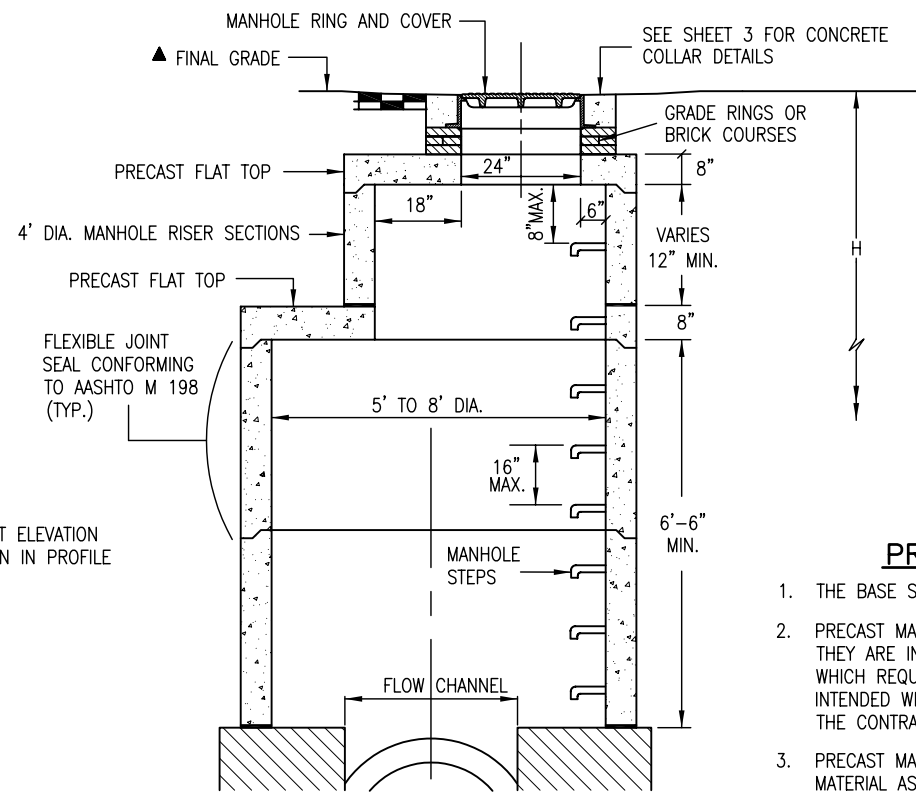

MANHOLE RISER DETAIL

LEGEND

	SUITABLE SUBGRADE
	GRANULAR BEDDING MATERIAL
	CONCRETE

PRECAST MANHOLE BASES NOTES:

1. THE BASE SLAB SHALL BE POURED MONOLITHICALLY WITH BOTTOM RISER SECTION.
2. PRECAST MANHOLE BASES SHALL FIT THE CONDITIONS AND LOCATIONS FOR WHICH THEY ARE INTENDED WITHOUT ANY FIELD MODIFICATIONS. ANY MANHOLE BASE WHICH REQUIRES FIELD CUTTING OR MODIFICATION IN ORDER TO FIT THE LOCATIONS INTENDED WILL BE REJECTED BY THE ENGINEER AND REMOVED AND REPLACED BY THE CONTRACTOR AT NO COST TO THE DEPARTMENT.
3. PRECAST MANHOLE BASES SHALL BE BEDDED ON AN APPROVED GRANULAR BEDDING MATERIAL AS SHOWN ABOVE.

Computer File Information

Creation Date: 07/04/06	Initials: SJR
Last Modification Date: 07/04/06	Initials: LTA
Full Path: www.dot.state.co.us/DesignSupport/	
Drawing File Name: 6040200203.dwg	
CAD Ver.: MicroStation V8	Scale: Not to Scale Units: English

Sheet Revisions

Date:	Comments
(R-X)	
(R-X)	
(R-X)	
(R-X)	

Colorado Department of Transportation
 4201 East Arkansas Avenue
 Denver, Colorado 80222
 Phone: (303) 757-9083
 Fax: (303) 757-9820
Project Development Branch SRJ/LTA

MANHOLES
 Issued By: Project Development Branch on July 04, 2006

STANDARD PLAN NO.
M-604-20
Sheet No. 2 of 3

T-BASE MANHOLES NOTES

1. THE T-BASE SECTION SHALL BE SHOP-FABRICATED FOR DELIVERY TO THE CONSTRUCTION SITE AS A COMPLETE UNIT.
2. THESE DETAILS SHOW ONLY THE CONCEPTUAL AND STANDARD DIMENSIONAL REQUIREMENTS FOR TYPE T-BASE MANHOLES. THE CONTRACTOR SHALL FURNISH DETAILED SHOP DRAWINGS FOR APPROVAL PRIOR TO FABRICATION. THE DETAILS SHOWN HEREIN APPLY ONLY TO 48 IN. AND GREATER DIAMETER PIPES.
3. EXCEPT FOR CLASS OF PIPE, SPECIFICATIONS FOR THE MANHOLE SHALL BE THE SAME AS THOSE REQUIRED FOR THE ADJOINING PIPE.
4. THE T-BASE SECTION SHALL MAINTAIN ITS INTERNAL SHAPE AND FLOW AREA. GROUTING OR FILLING SHALL BE APPLIED SO AS TO NOT DISTURB THE NORMAL FLOW OR REDUCE THE AREA.

WHEN ADJUSTMENT HEIGHT IS 3 IN. OR LESS, METAL ADJUSTMENT RINGS COMPATIBLE WITH THE EXISTING MANHOLE RING AND COVER MAY BE USED IF APPROVED BY THE ENGINEER.

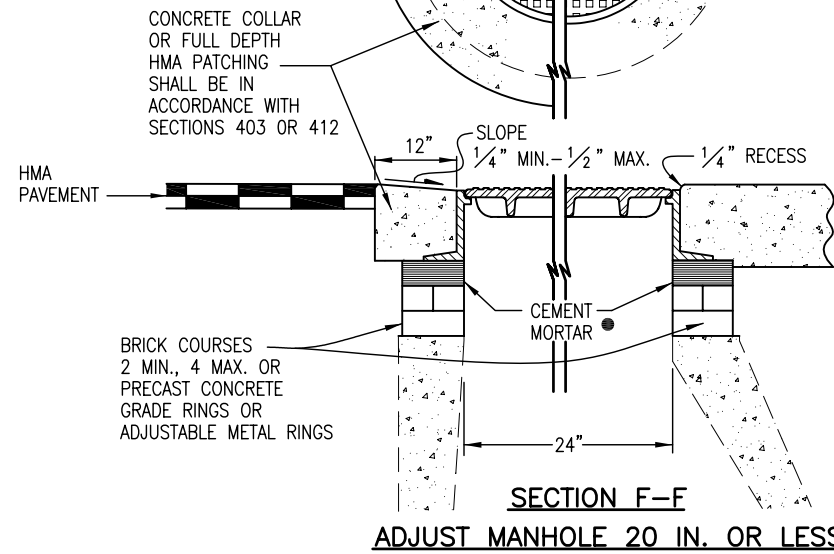
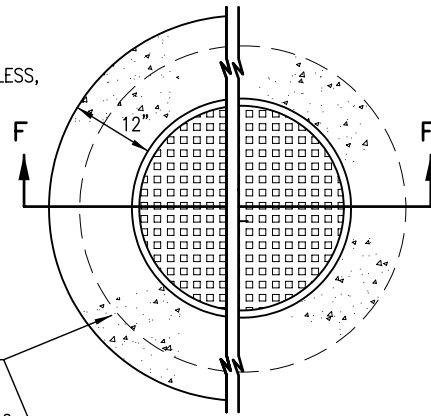

MORTAR THICKNESS MAY BE NONSYMMETRICAL TO MATCH CROSS SLOPE OF ROADWAY.

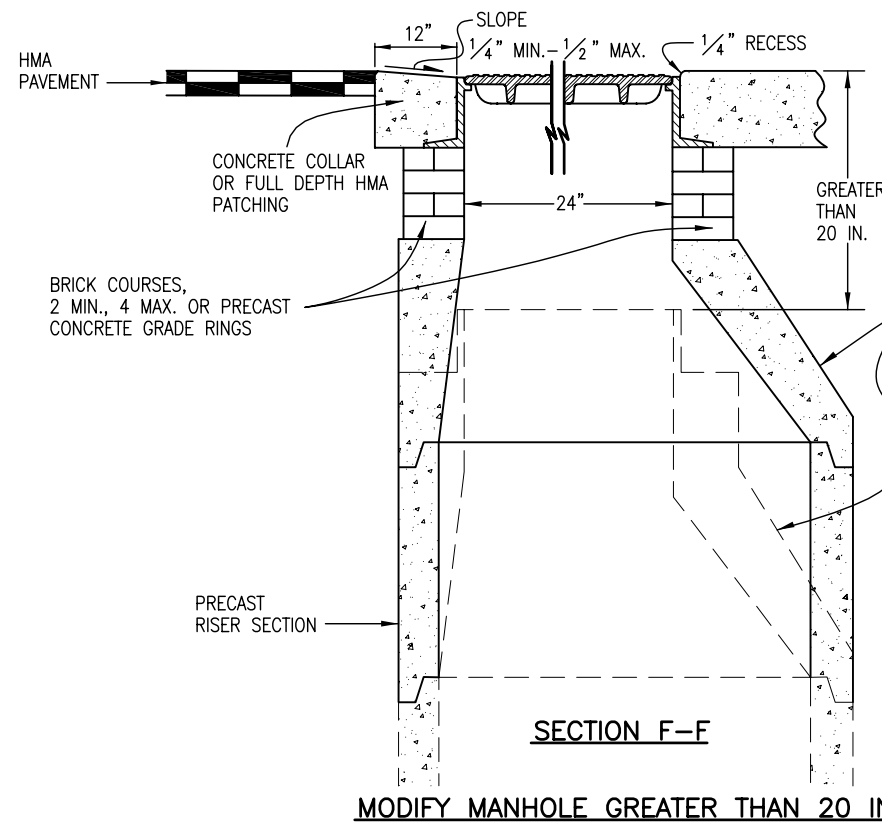

RESET ECCENTRIC CONE. WORK WILL NOT BE MEASURED AND PAID FOR SEPARATELY, BUT SHALL BE INCLUDED IN THE WORK

▲ WHEN FINAL GRADE IS PAVEMENT SURFACE, RECESS MANHOLE RING AND COVER 1/4" MIN. TO 1/2" MAX.

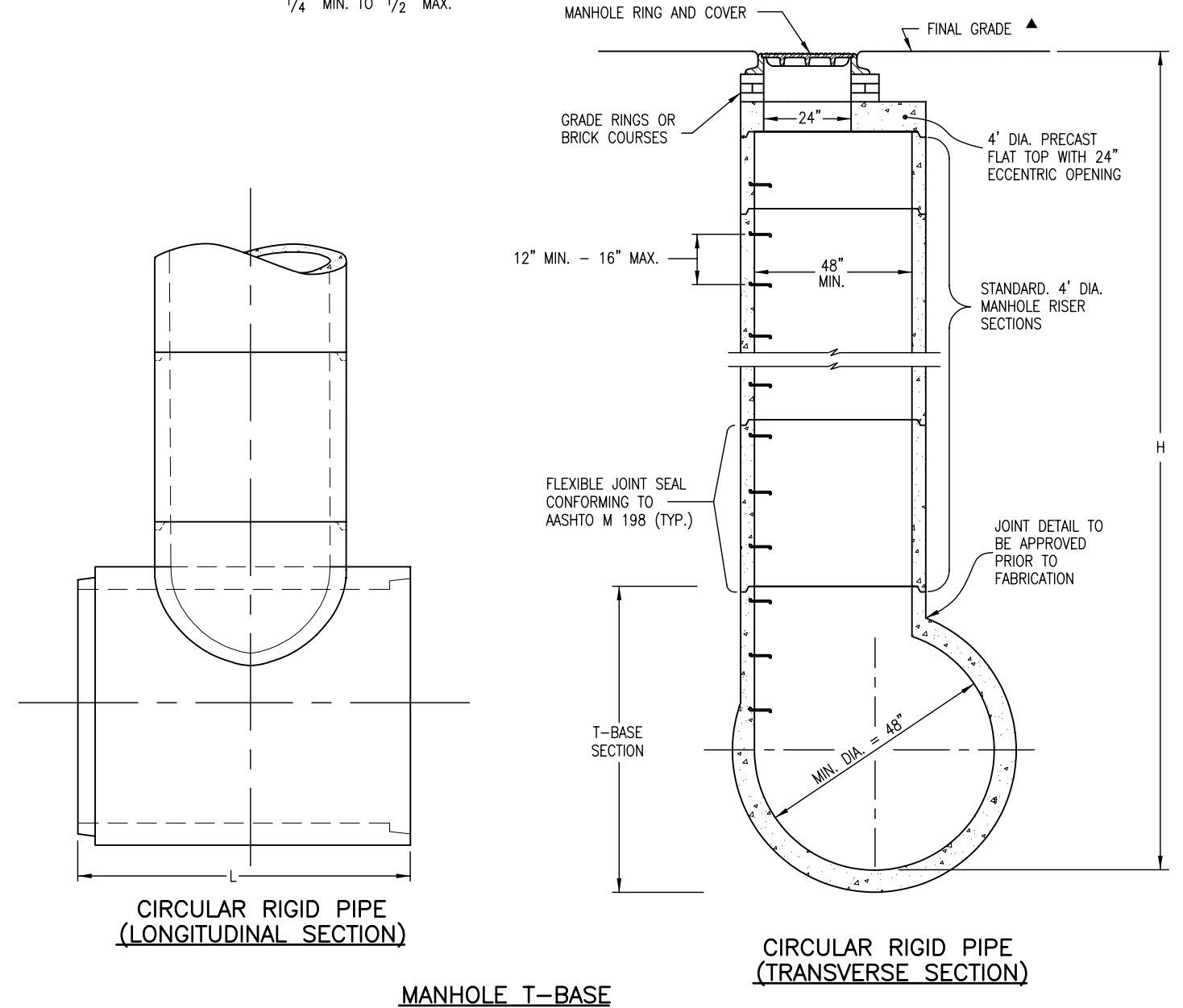

Computer File Information	
Creation Date: 07/04/06	Initials: SJR
Last Modification Date: 07/04/06	Initials: LTA
Full Path: www.dot.state.co.us/DesignSupport/	
Drawing File Name: 6040200303.dwg	
CAD Ver.: MicroStation V8 Scale: Not to Scale Units: English	

Sheet Revisions	
Date:	Comments
(R-X)	
(R-X)	
(R-X)	
(R-X)	

Colorado Department of Transportation

4201 East Arkansas Avenue
Denver, Colorado 80222
Phone: (303) 757-9083
Fax: (303) 757-9820

Project Development Branch SRJ/LTA

MANHOLES

Issued By: Project Development Branch on July 04, 2006

STANDARD PLAN NO.

M-604-20

Sheet No. 3 of 3