

GENERAL NOTES

- RUMBLE STRIPS SHALL BE OMITTED AT TURN AND AUXILIARY LANES, ROAD APPROACHES, RESIDENCES, 250 FT. BEFORE ROAD INTERSECTIONS, AND OTHER INTERRUPTIONS AS DIRECTED BY THE ENGINEER.
- RUMBLE STRIPS MAY BE INSTALLED BY GRINDING, ROLLING, OR FORMING ON CONCRETE PAVEMENT, AND BY GRINDING ONLY ON HMA PAVEMENT. RUMBLE STRIP WIDTH SHALL BE 12 IN. FOR GRIND-IN AND 18 IN. FOR FORMED OR ROLLED.
- MINIMIZE THE DISTANCE BETWEEN RUMBLE STRIP AND EDGE LINE ON CONCRETE PAVEMENTS WITH 14 FT. WIDE SLABS.
- BEGIN RUMBLE STRIPS ON THE OUTSIDE EDGE OF THE TRAVEL LANE EDGE LINE.
- DO NOT INSTALL RUMBLE STRIPS ON SHOULDERS LESS THAN 6 FT. WIDE WHEN GUARDRAIL IS PLACED ALONG THE EDGE OF THE SHOULDER.
- APPLY THE 60 FT. GAP PATTERN WHEN RUMBLE STRIPS (GRIND-IN) ARE INSTALLED IN CONCRETE PAVEMENT.

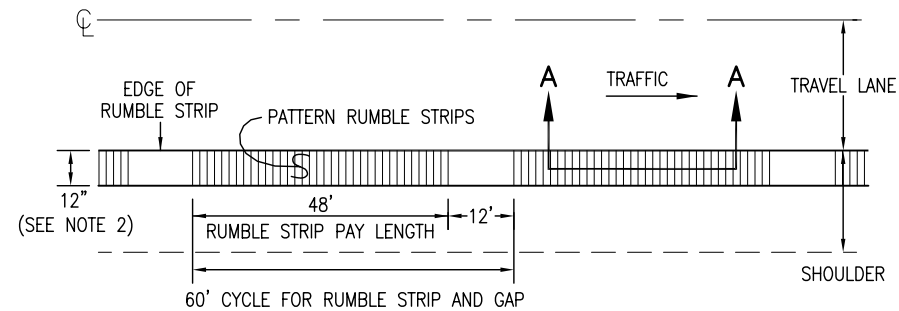

**INTERMITTENT RUMBLE STRIP
TWO-LANE ROADWAY (HMA)**

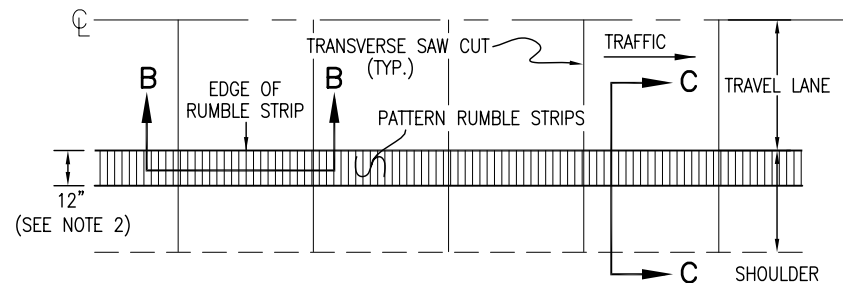

**CONTINUOUS RUMBLE STRIP
TWO-LANE ROADWAY (CONCRETE)**

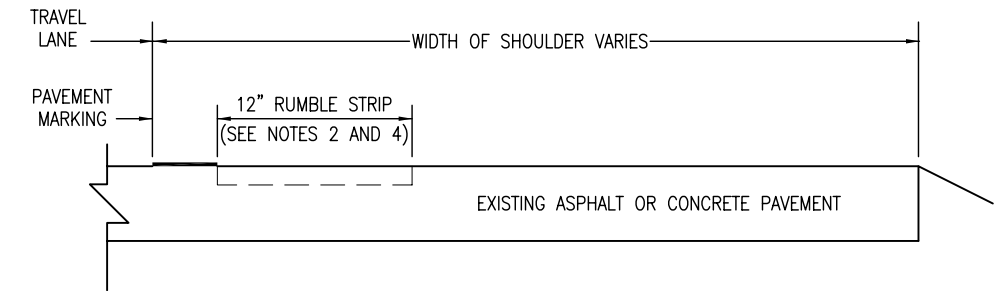

TYPICAL SECTION C-C

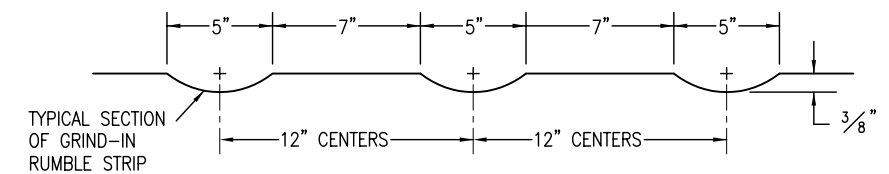

**TYPICAL SECTIONS A-A AND B-B
FOR GRIND-IN RUMBLE STRIP
ON EXISTING HMA OR CONCRETE PAVEMENT**

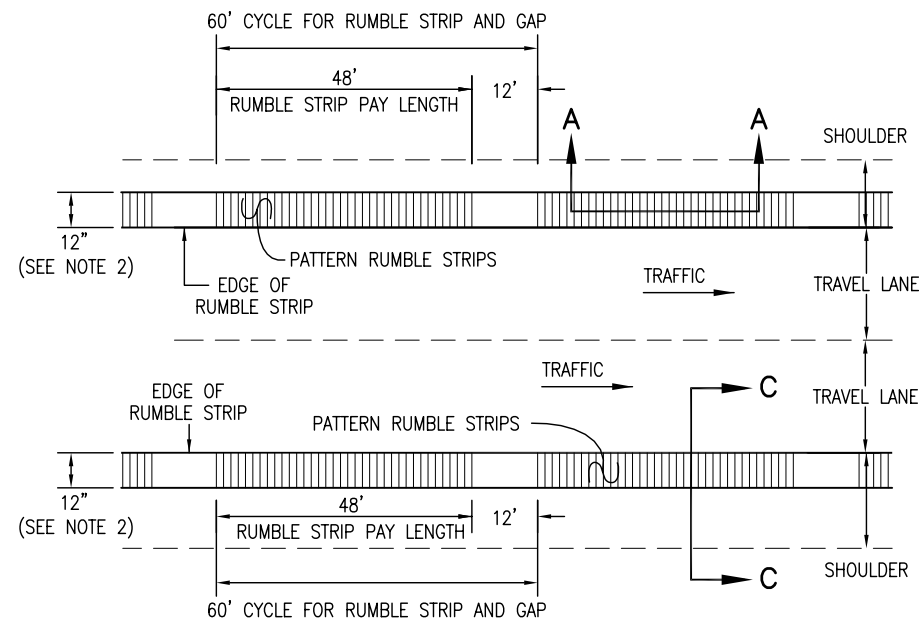

**INTERMITTENT RUMBLE STRIP
FOUR-LANE DIVIDED ROADWAY (HMA)**

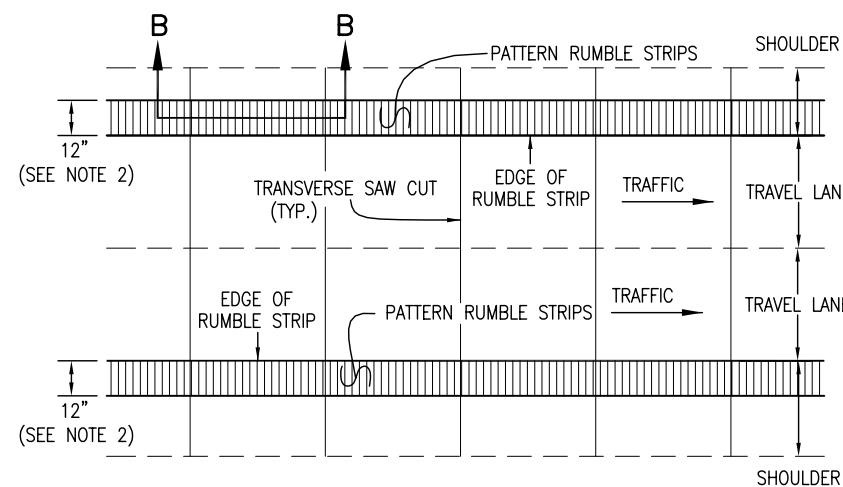

**CONTINUOUS RUMBLE STRIP
FOUR-LANE DIVIDED ROADWAY (CONCRETE)**

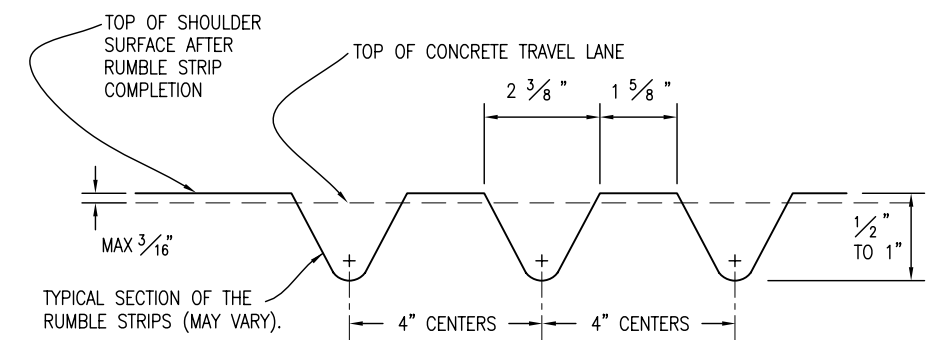

**TYPICAL SECTION B-B
FOR FORMED OR ROLLED ON CONCRETE PAVEMENTS ONLY**

Computer File Information		Sheet Revisions		Colorado Department of Transportation  4201 East Arkansas Avenue Denver, Colorado 80222 Phone: (303) 757-9083 Fax: (303) 757-9820 Project Development Branch SRJ/LTA	<h1>RUMBLE STRIPS</h1>	STANDARD PLAN NO.
Creation Date: 07/04/06	Initials: SJR	Date:	Comments:			M-614-1
Last Modification Date: 07/04/06	Initials: LTA					Sheet No. 1 of 3
Full Path: www.dot.state.co.us/DesignSupport/						
Drawing File Name: 614010103.dwg						
CAD Ver.: MicroStation V8 Scale: Not to Scale Units: English					Issued By: Project Development Branch on July 04, 2006	

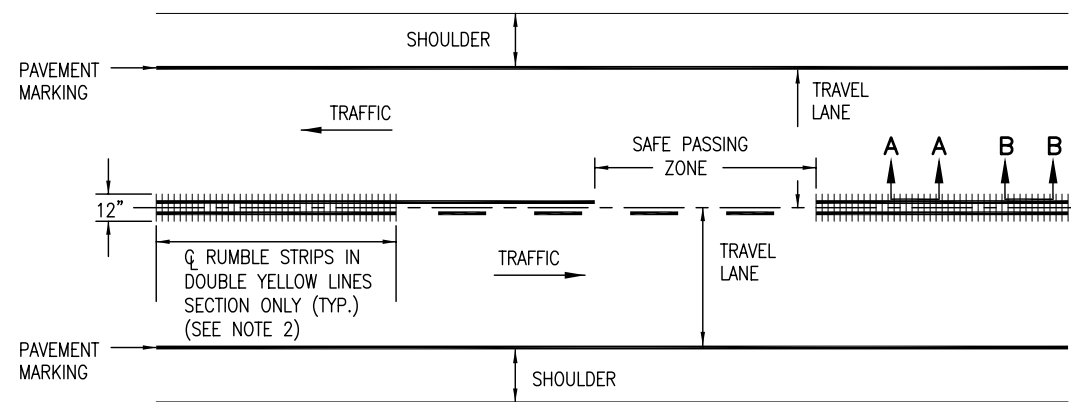

**TWO LANE HIGHWAY (HMA AND CONCRETE)
CONTINUOUS CENTER LINE RUMBLE STRIPS**

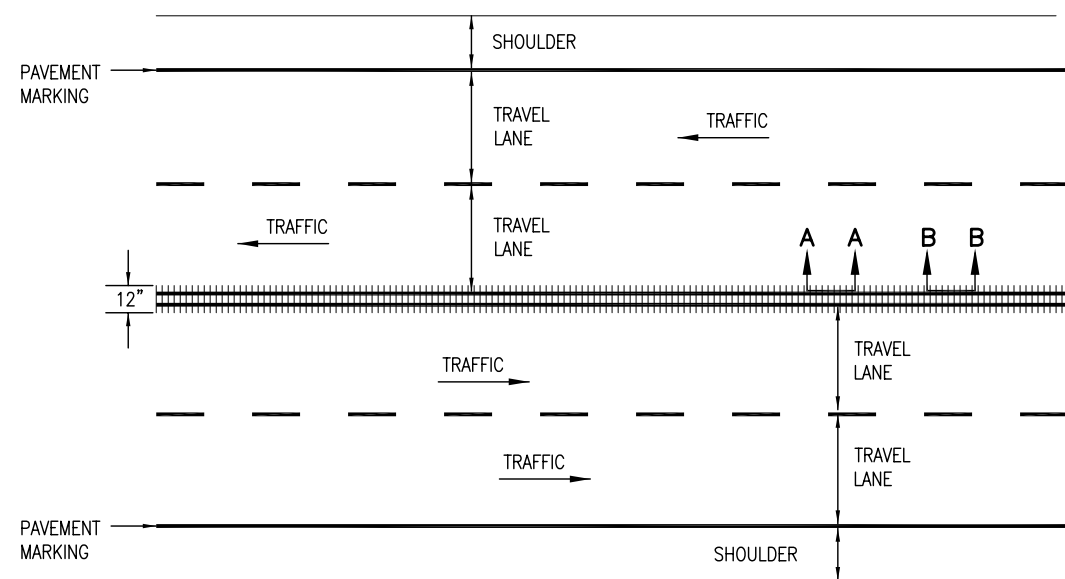

**FOUR LANE UNDIVIDED HIGHWAY (HMA AND CONCRETE)
CONTINUOUS CENTER LINE RUMBLE STRIPS**

NOTES

1. RUMBLE STRIP WIDTH SHALL BE 12 IN. FOR GRIND-IN, FORMED, OR ROLLED.
2. CENTERLINE RUMBLE STRIPS MAY BE CONTINUOUS THROUGH PASSING ZONES AS DETERMINED BY THE ENGINEER AND SHOWN ON THE PLANS.

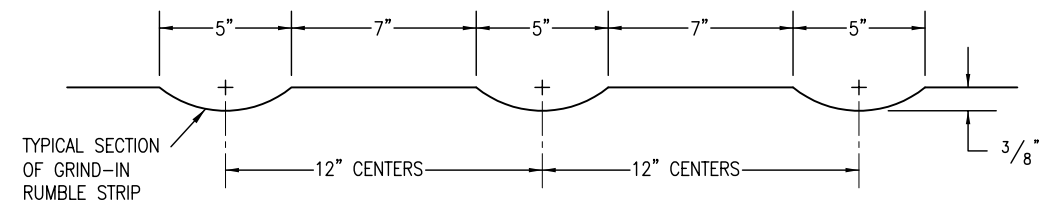

TYPICAL SECTIONS A-A AND B-B

FOR GRIND-IN RUMBLE STRIP
ON EXISTING ASPHALT OR CONCRETE PAVEMENT

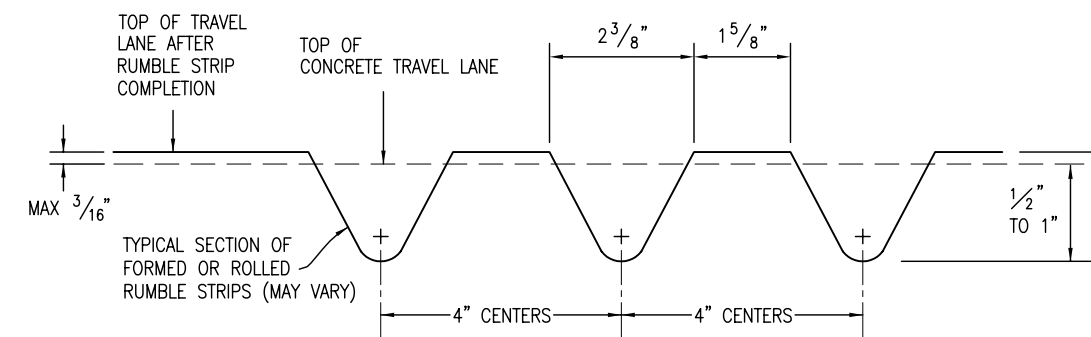

TYPICAL SECTION B-B

FOR FORMED OR ROLLED ON CONCRETE PAVEMENTS ONLY

DETAILS FOR CENTER LINE RUMBLE STRIPS

Computer File Information		Sheet Revisions		Colorado Department of Transportation  4201 East Arkansas Avenue Denver, Colorado 80222 Phone: (303) 757-9083 Fax: (303) 757-9820 Project Development Branch SRJ/LTA	<h1>RUMBLE STRIPS</h1>	STANDARD PLAN NO.
Creation Date: 07/04/06	Initials: SJR	Date:	Comments:			M-614-1
Last Modification Date: 07/04/06	Initials: LTA					
Full Path: www.dot.state.co.us/DesignSupport/						
Drawing File Name: 614010203.dwg						
CAD Ver.: MicroStation V8	Scale: Not to Scale	Units: English			Issued By: Project Development Branch on July 04, 2006	Sheet No. 2 of 3

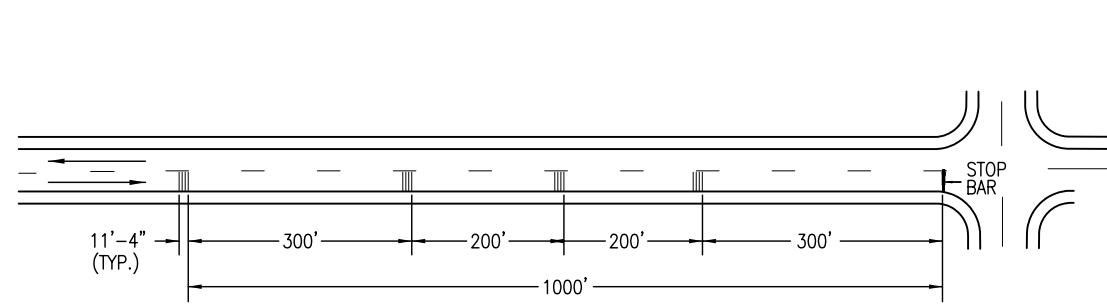

STOP SIGN APPROACH

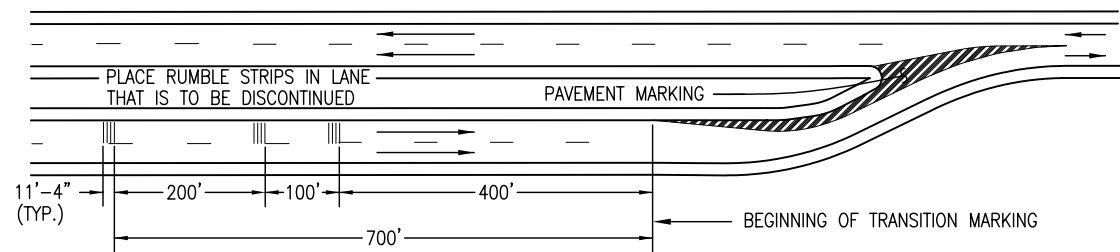

LANE REDUCTION TRANSITION

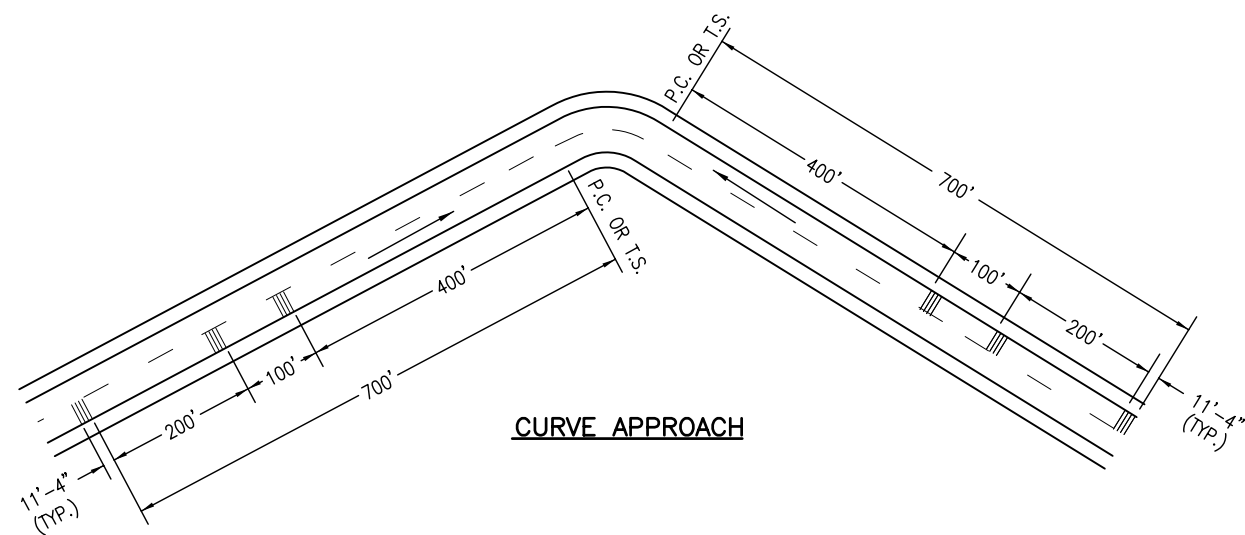

TRAVEL LANE RUMBLE STRIPS

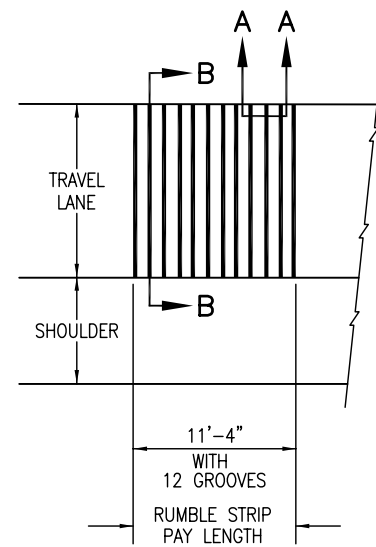

TYPICAL RUMBLE STRIP CLUSTER

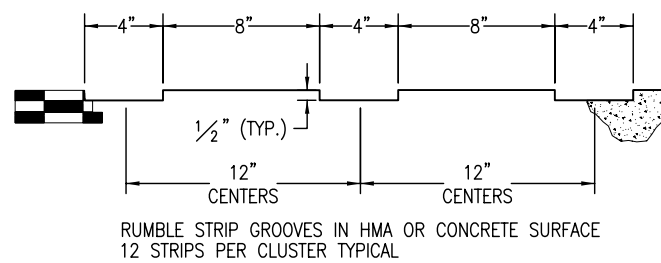

RUMBLE STRIP GROOVES IN HMA OR CONCRETE SURFACE
12 STRIPS PER CLUSTER TYPICAL

SECTION A-A (GROOVED)

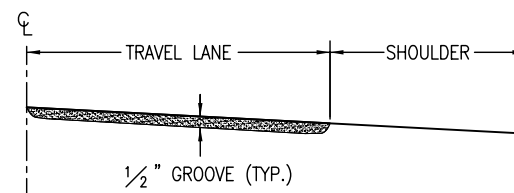

SECTION B-B (GROOVED)

PERMANENT GROOVED RUMBLE STRIPS

- NOTES**
- GROOVED RUMBLE STRIP SKEW OR CLUSTER SPACING SHALL BE MODIFIED TO AVOID LOCATING A GROOVE ON A CONCRETE PAVEMENT TRANSVERSE JOINT.
 - PERMANENT TRAVEL LANE RUMBLE STRIPS SHALL BE THE GROOVE DESIGN, AND MAY BE CUT IN EXISTING OR NEW HMA OR CONCRETE PAVEMENT. THE GROOVES MAY BE CUT BY SAWING, GRINDING, OR OTHER METHOD AS APPROVED.
 - TEMPORARY RUMBLE STRIPS SHOULD NORMALLY BE THE RAISED DESIGN. THEY MAY BE GROOVES IF LOCATED IN A PAVEMENT THAT WILL BE REMOVED OR COVERED WITH A PAVEMENT COURSE BEFORE COMPLETION OF THE PROJECT. TYPICAL USES OF TEMPORARY RUMBLE STRIPS ARE FOR LANE CLOSURES OR ALIGNMENT CHANGES IN CONSTRUCTION ZONES.
 - THE HMA (RAISED RUMBLE STRIPS) SHALL BE PLACED ON A CLEAN, TACK COATED TREATED PAVEMENT IN $\frac{3}{8}$ IN. HIGH FORMS. THE FORMS SHALL BE REMOVED AND THE ASPHALT COMPACTED BY ROLLING ALONG THE STRIPS. EPOXY MORTAR SHALL BE FORMED, TROWELED, AND LEVELED WITH A ROLLER AND THE TOP EDGES ROUNDED, THERMOPLASTIC STRIPS SHALL BE APPLIED BY THE EXTRUSION PROCESS. PREFORMED PLASTIC SHALL BE INSTALLED IN CONFORMANCE WITH THE INSTRUCTIONS OF THE MANUFACTURER.

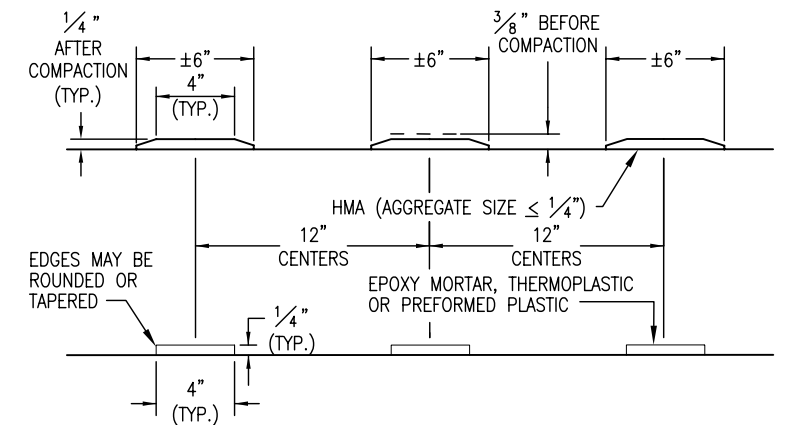

PREFORMED PLASTIC STRIPS SHALL BE SPACED ON 12 IN. CENTERS AND MAY VARY FROM THE 4 IN. TYPICAL WIDTH. 12 STRIPS PER CLUSTER TYPICAL

SECTION A-A (RAISED)

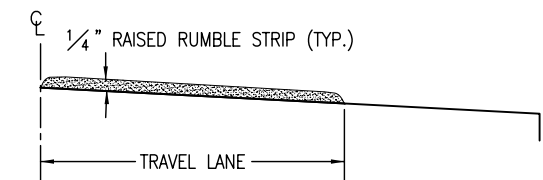

SECTION B-B (RAISED)

TEMPORARY RAISED RUMBLE STRIPS

Computer File Information

Creation Date: 07/04/06	Initials: SJR
Last Modification Date: 07/04/06	Initials: LTA
Full Path: www.dot.state.co.us/DesignSupport/	
Drawing File Name: 614010303.dwg	
CAD Ver.: MicroStation V8 Scale: Not to Scale Units: English	

(R-X)
(R-X)
(R-X)
(R-X)

Sheet Revisions

Date:	Comments

Colorado Department of Transportation

4201 East Arkansas Avenue
Denver, Colorado 80222
Phone: (303) 757-9083
Fax: (303) 757-9820

Project Development Branch SRJ/LTA

RUMBLE STRIPS

Issued By: Project Development Branch on July 04, 2006

STANDARD PLAN NO.

M-614-1

Sheet No. 3 of 3