



April 16, 2008

In Reply Refer To: HSSD/B-171

Tim Aschenbrenner, P.E.  
Project Development Branch Manager  
Colorado Department of Transportation  
4201 East Arkansas Avenue  
Denver, CO 80222-3400

Dear Mr. Aschenbrenner:

This letter is in response to your request for Federal Highway Administration (FHWA) acceptance of a roadside safety system for use on the National Highway System (NHS).

Name of system: Colorado Portable Concrete Barrier  
Type of system: Modified F-Shape Concrete Median Barrier  
Test Level: Test Level 3 (TL-3)  
Testing conducted by: [N/A; Modification of Oregon CMB in B-86]

You requested that we find this system acceptable for use on the NHS under the provisions of National Cooperative Highway Research Program (NCHRP) Report 350 "Recommended Procedures for the Safety Performance Evaluation of Highway Features."

### **Requirements**

Roadside safety systems should meet the guidelines contained in the NCHRP Report 350, "Recommended Procedures for the Safety Performance Evaluation of Highway Features". FHWA Memorandum "ACTION: Identifying Acceptable Highway Safety Features" of July 25, 1997, provides further guidance on crash testing requirements of longitudinal barriers.

### **Description**

The Colorado portable concrete barrier is a modification of the Oregon barrier covered in FHWA acceptance letter B-86 dated August 17, 2001. Drawings of the Colorado barrier, the Oregon barrier, and a comparison of the two shapes are enclosed for reference. Here is a brief description of the Colorado barrier:

Each 12-foot, 6-inch long barrier segment is reinforced longitudinally with eight #5 bars. The barrier is 34 inches tall, 23 inches wide at the base, and 8 inches wide at the top. The distance from the ground to the slope break point is 11 inches which is 1 inch higher than the standard "F" shape and 2 inches lower than the New Jersey shape.

The pin and loop connection consists of two 3/4-inch A36 steel loops near the top of one segment end, above a single 3/4-inch steel loop near the bottom on the same end. The corresponding loops on the adjacent barrier segment consisted of a single loop near the top and double loops on the bottom. When placed together, the single loops fit between the double loops, forming two connection points, each consisting of three loops. A one-inch diameter, 29-inch long ASTM A449 steel pin, with no nut or retention device, is dropped through the loops to complete the connection.

### **Crash Testing**

The Oregon barrier was tested by KARCO Engineering and had a deflection of 30 inches. The modified Colorado barrier is approximately 5 percent lighter, a factor which should have no significant effect on the crashworthiness of the barrier system.

### **Findings**

We concur that the Colorado portable concrete barrier system is comparable to the Oregon barrier that was previously accepted and is acceptable for use on the NHS as a TL-3 barrier when allowed by the highway agency.

Please note the following standard provisions that apply to FHWA letters of acceptance:

- This acceptance is limited to the crashworthiness characteristics of the system and does not cover their structural features, nor conformity with the Manual on Uniform Traffic Control Devices.
- Any changes that may adversely influence the crashworthiness of the system will require a new acceptance letter.
- Should the FHWA discover that the qualification testing was flawed, that in-service performance reveals unacceptable safety problems, or that the system being marketed is significantly different from the version that was crash tested, we reserve the right to modify or revoke our acceptance.
- You will be expected to supply potential users with sufficient information on design and installation requirements to ensure proper performance.
- You will be expected to certify to potential users that the hardware furnished has essentially the same chemistry, mechanical properties, and geometry as that submitted for acceptance, and that it will meet the crashworthiness requirements of the FHWA and the NCHRP Report 350.
- To prevent misunderstanding by others, this letter of acceptance is designated as number B-171 and shall not be reproduced except in full. This letter and the test documentation upon which it is based are public information. All such letters and documentation may be reviewed at our office upon request.
- This acceptance letter shall not be construed as authorization or consent by the FHWA to use, manufacture, or sell any patented system for which the applicant is not the patent holder. The acceptance letter is limited to the crashworthiness characteristics of the

candidate system, and the FHWA is neither prepared nor required to become involved in issues concerning patent law. Patent issues, if any, are to be resolved by the applicant.

Sincerely yours,

A handwritten signature in blue ink, appearing to read "George Eric J.", is written over a light blue rectangular background.

for

David A. Nicol, P.E.  
Director, Office of Safety Design  
Office of Safety

Enclosures

## Oregon DOT and Colorado DOT Side by Side Comparison

\*\* DIMENSIONS MARKED THUS ARE TO THE INTERSECTION POINT OF THE BARRIER SLOPES. CONSTRUCT THE 10 IN. RADIUS TO PROVIDE A SMOOTH TRANSITION BETWEEN THE SLOPES.

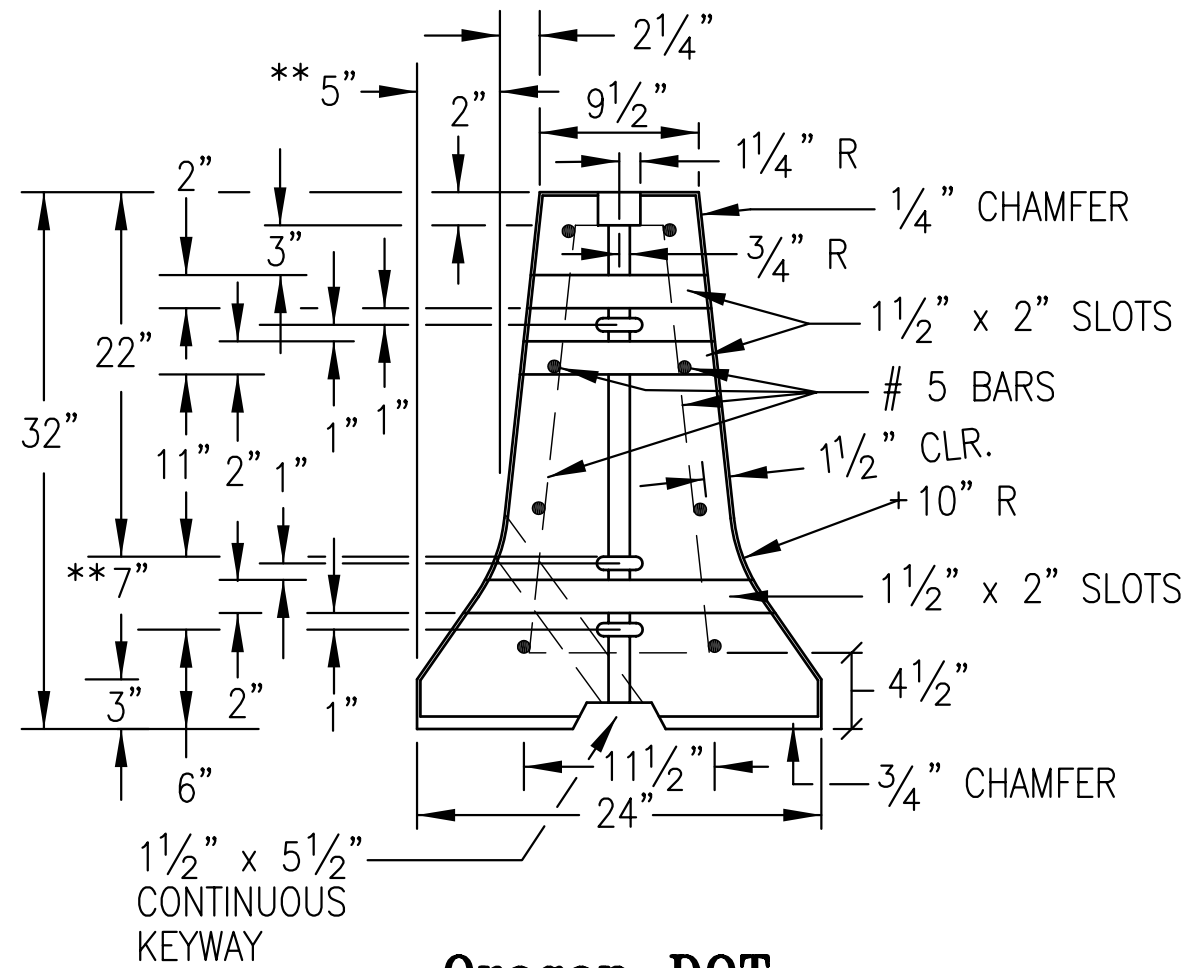

**Oregon DOT**

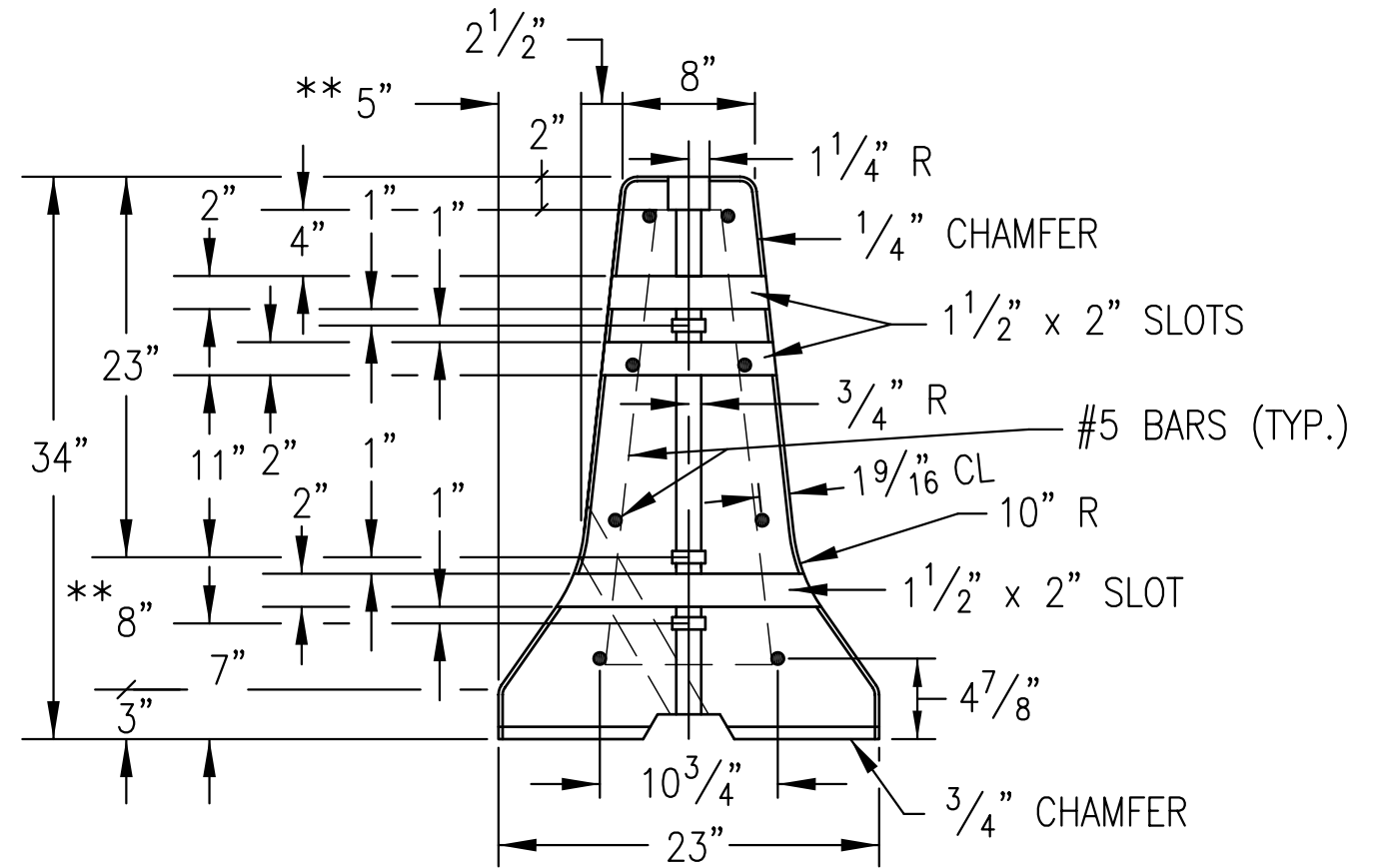

**Colorado DOT**

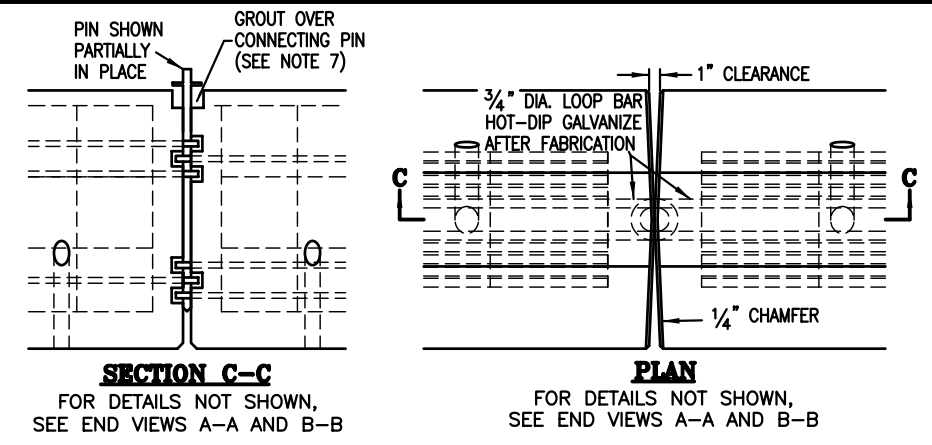
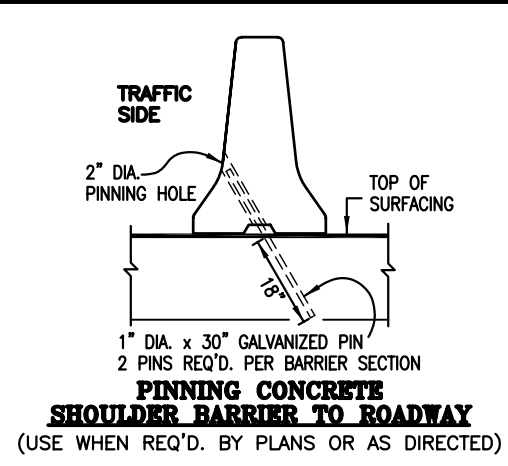

**PIN AND LOOP CONNECTION**

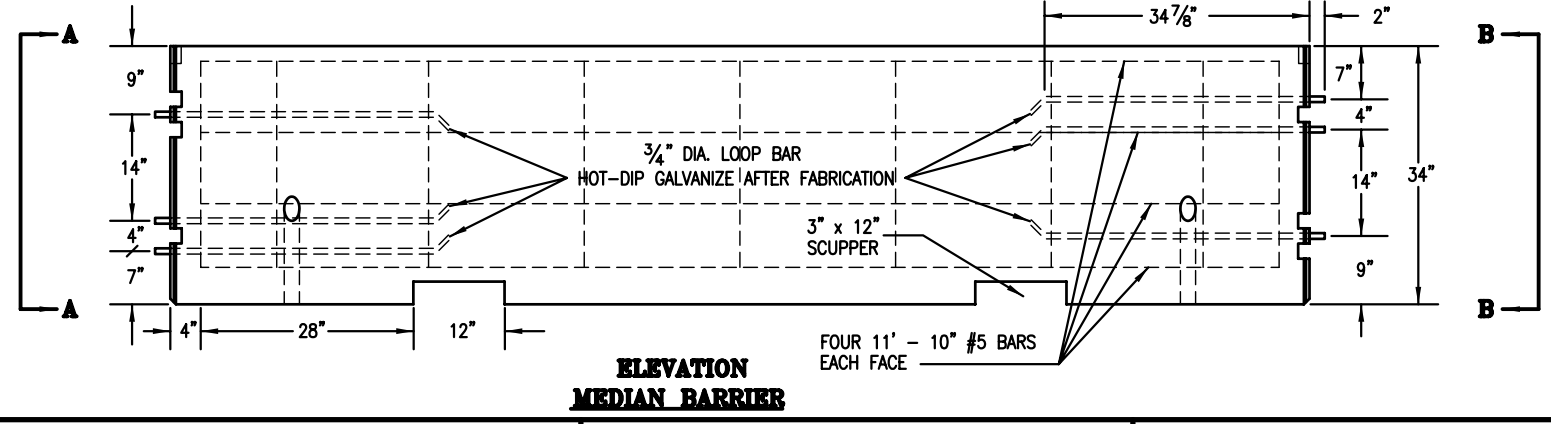
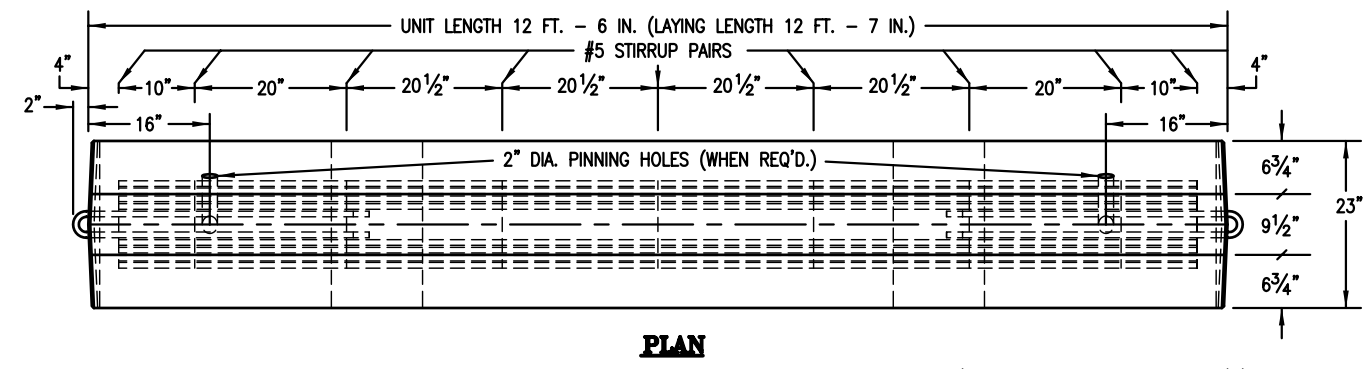
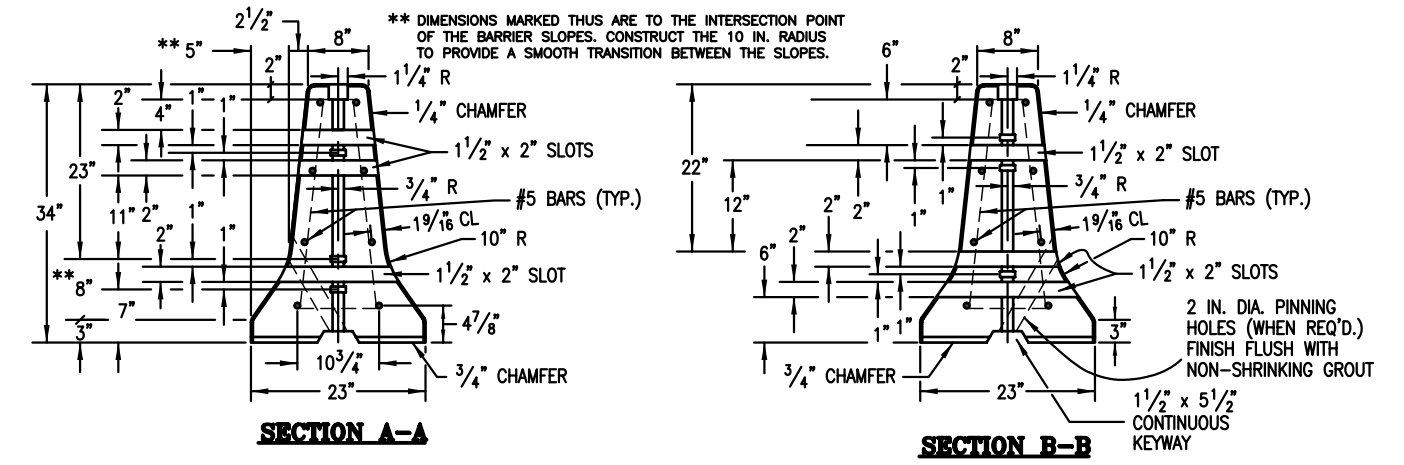

**ELEVATION  
MEDIAN BARRIER**

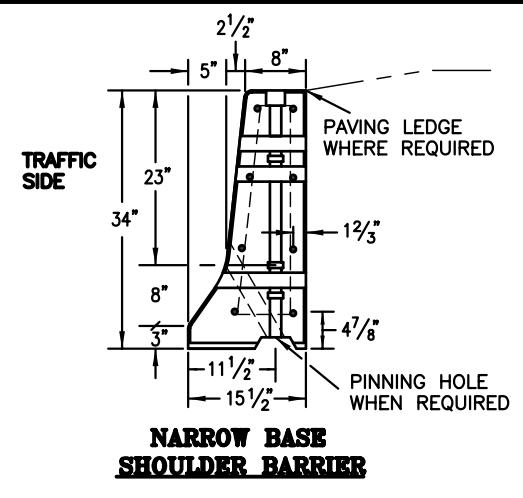

**NARROW BASE  
SHOULDER BARRIER**

**PIN NOTES**

1. WASHER SHALL BE FORGED AS INTERGAL PART OF PIN, OR SHALL BE WELDED AS SHOWN.
2. PIN SHALL BE GALVANIZED AFTER FABRICATION.
3. PIN THAT CONFORM TO CRITICAL DIMENSIONS, (PIN LENGTH & DIA., WASHER DIA. & THKN.) ARE ACCEPTABLE. IF AN APPROVED TOP CONFIGURATION FOR LIFTING THE PIN IS PROVIDED.
4. PIN AND WASHER SHALL CONFORM TO ASTM A449.

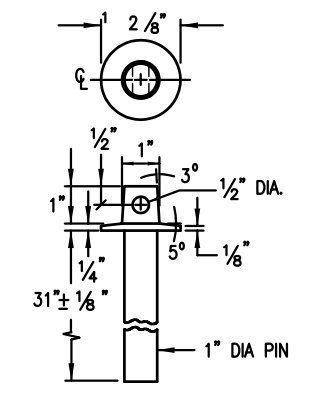

**ALTERNATE  
PIN DETAIL**

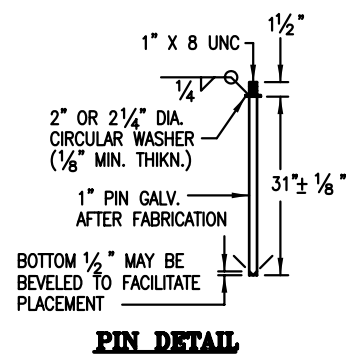

**PIN DETAIL**

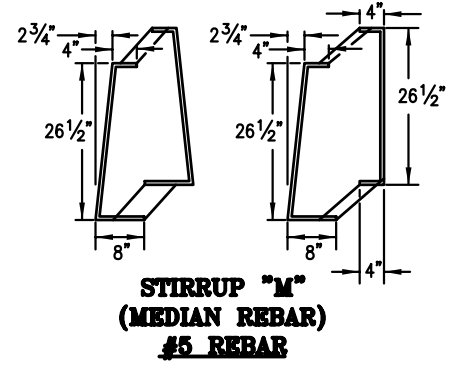

**STIRRUP "M"  
(MEDIAN REBAR)  
#5 REBAR**

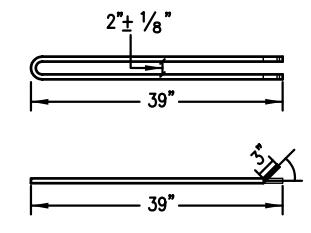

**REPLACEMENT DETAIL**

**GENERAL NOTES**

1. ALL METAL REINFORCEMENT SHALL BE 2 IN. CLEAR OF NEAREST FACE OF CONCRETE UNLESS OTHERWISE SHOWN.
2. MAXIMUM CHORD LENGTH FOR CURVES WITH 1425 FT. RADIUS OR LESS, SHALL BE 12.5 FT. MINIMUM CHORD LENGTH FOR CURVES WITH RADIUS EXCEEDING 1425 FT. SHALL BE 25 FT.
3. NORMAL USE OF PRECAST BARRIER UNITS IS RESTRICTED TO CURVATURES WITH RADII GREATER THEN 770 FT.
4. NARROW BASE SHOULDER BARRIER TO BE USED ONLY AT LOCATIONS WITH BACKFILL BEHIND BARRIER AS SHOWN ON PLANS.
5. PORTABLE CONCRETE BARRIER TO BE PRECAST CONCRETE MEDIAN THEN 770 FT.
6. WHEN SCUPPERS ARE NOT REQUIRED, PLUG THEM WITH A MINIMUM 2 IN. OF GROUT.
7. CONCRETE GROUT FOR GROUTING OVER PINS, PINNING HOLES, OR GROUTING OF SCUPPERS, SHALL BE A NON-SHRINKING GROUT, WEAK IN STRENGTH AND OF THICK CONSISTENCY.
8. PRECAST BARRIER USED AS A PERMANENT MEDIAN BARRIER IN MEDIANS LESS THEN 8 FT. IN WIDTH, SHALL BE ANCHORED TO THE ROADWAY.

**Colorado DOT Proposal**

Colorado Department of Transportation  4201 East Arkansas Avenue Denver, Colorado 80222 Phone: (303) 757-9083 FAX: (303) 757-9820 Project Development Branch SD	Computer File Information		Standard Plan Revised		<b>PORTABLE CONCRETE BARRIER</b>	<b>STANDARD PLAN NO. M-606-12</b>	
	Path: www.dot.state.co.us/DevelopProjects/DesignSupport/MStandards/		Date:	Comments:			Issued By: Project Development Branch Month Date, 2002
	Drawing File Name: 6060120101.dwg						
	Acad Version: R14 Scale: NA Units: English						

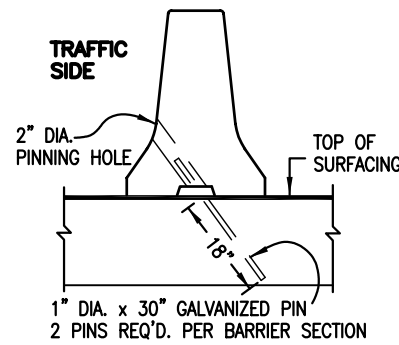

**PINNING CONCRETE  
SHOULDER BARRIER TO ROADWAY**  
(USE WHEN REQ'D. BY PLANS OR AS DIRECTED)

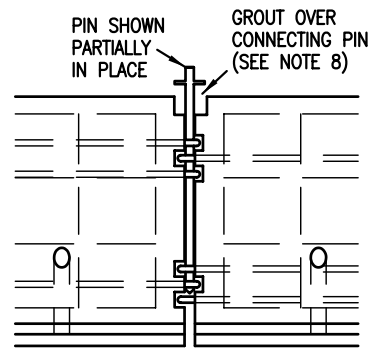

**SECTION C-C**  
FOR DETAILS NOT SHOWN, SEE END VIEWS A-A AND B-B

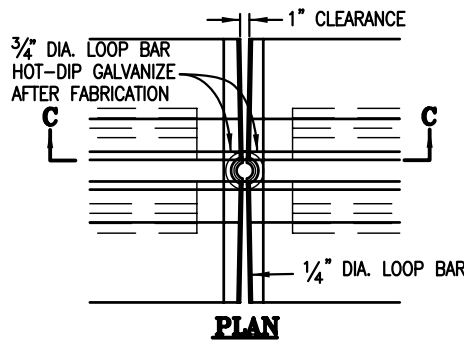

**PLAN**  
FOR DETAILS NOT SHOWN, SEE END VIEWS A-A AND B-B

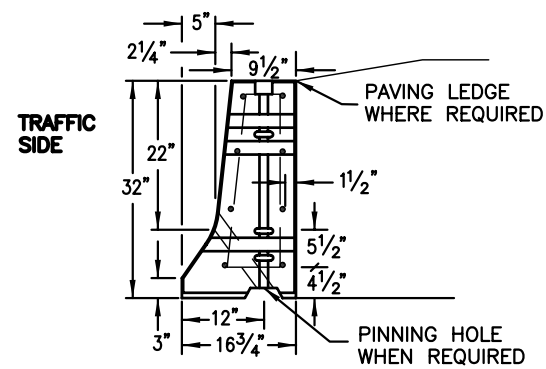

**NARROW BASE SHOULDER BARRIER**

**GENERAL NOTES**

1. ALL METAL REINFORCEMENT SHALL BE 2 IN. CLEAR OF NEAREST FACE OF CONCRETE UNLESS OTHERWISE SHOWN.
2. MAXIMUM CHORD LENGTH FOR CURVES WITH 1425 FT. RADIUS OR LESS, SHALL BE 12.5 FT. MINIMUM CHORD LENGTH FOR CURVES WITH RADIUS EXCEEDING 1425 FT. SHALL BE 25 FT.
3. NORMAL USE OF PRECAST BARRIER UNITS IS RESTRICTED TO CURVATURES WITH RADII GREATER THEN 770 FT.
4. NARROW BASE SHOULDER BARRIER TO BE USED ONLY AT LOCATIONS WITH BACKFILL BEHIND BARRIER AS SHOWN ON PLANS.
5. PORTABLE CONCRETE BARRIER TO BE PRECAST CONCRETE MEDIAN THEN 770 FT.
6. WHEN SCUPPERS ARE NOT REQUIRED, PLUG THEM WITH A MINIMUM 2 IN. OF GROUT.
7. CONCRETE GROUT FOR GROUTING OVER PINS, PINNING HOLES, OR GROUTING OF SCUPPERS, SHALL BE A NON-SHRINKING GROUT, WEAK IN STRENGTH AND OF THICK CONSISTENCY.
8. PRECAST BARRIER USED AS A PERMANENT MEDIAN BARRIER IN MEDIANS LESS THEN 8 FT. IN WIDTH, SHALL BE ANCHORED TO THE ROADWAY.

**PIN NOTES**

1. WASHER SHALL BE FORGED AS INTERGAL PART OF PIN, OR SHALL BE WELDED AS SHOWN.
2. PIN SHALL BE GALVANIZED AFTER FABRICATION.
3. PIN THAT CONFORM TO CRITICAL DIMENSIONS, (PIN LENGTH & DIA., WASHER DIA. & THKN.) ARE ACCEPTABLE. IF AN APPROVED TOP CONFIGURATION FOR LIFTING THE PIN IS PROVIDED.
4. PIN AND WASHER SHALL CONFORM TO ASTM A449.

\*\* DIMENSIONS MARKED THUS ARE TO THE INTERSECTION POINT OF THE BARRIER SLOPES. CONSTRUCT THE 10 IN. RADIUS TO PROVIDE A SMOOTH TRANSITION BETWEEN THE SLOPES.

**PIN AND LOOP CONNECTION**

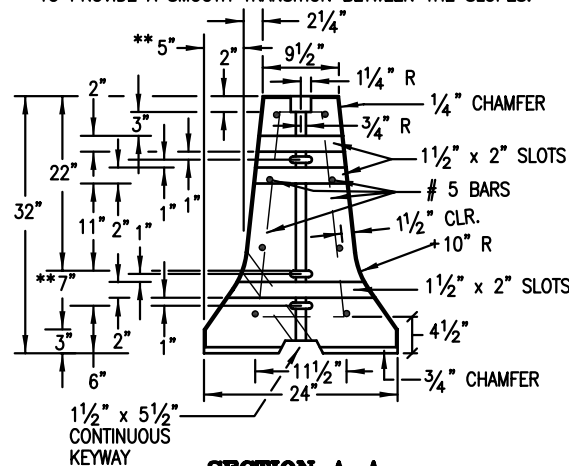

**SECTION A-A**

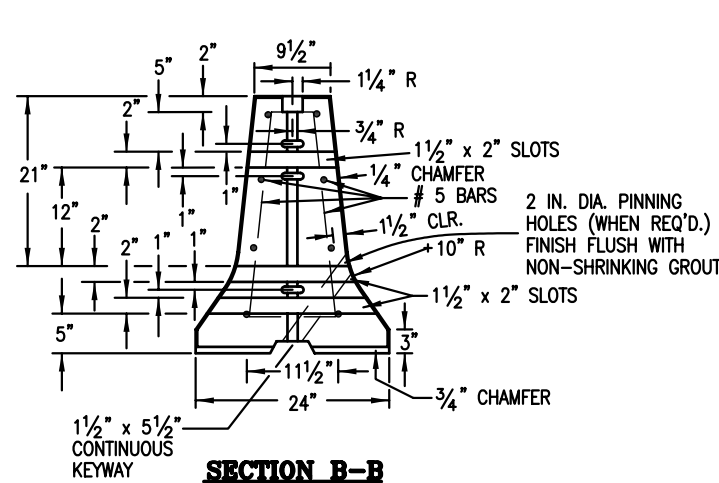

**SECTION B-B**

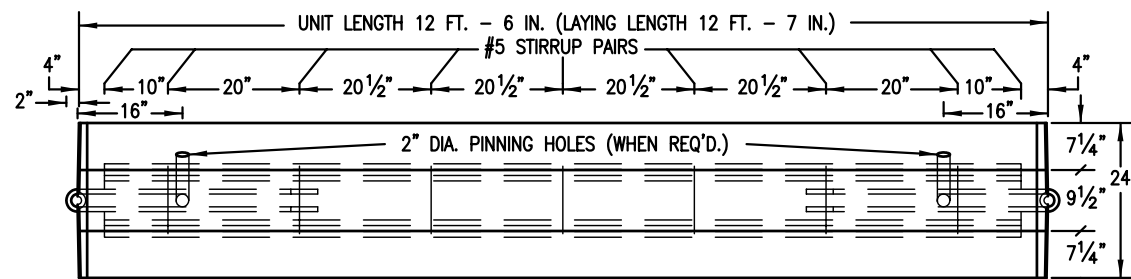

**PLAN**

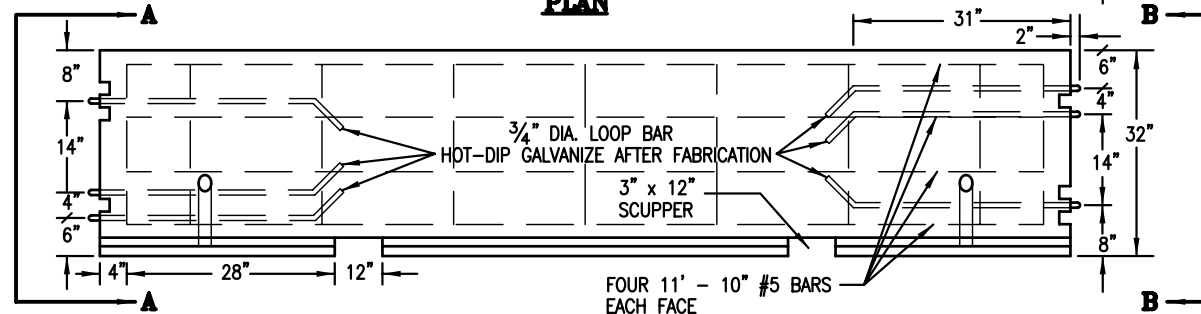

**ELEVATION  
MEDIAN BARRIER**

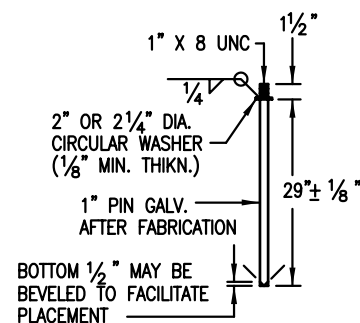

**PIN DETAIL**

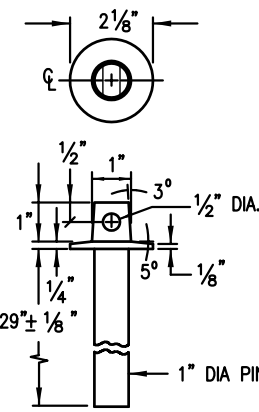

**ALTERNATE  
PIN DETAIL**

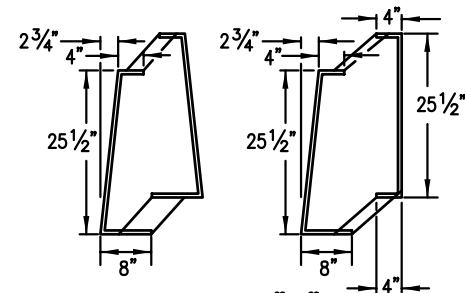

**STIRRUP "M"  
(MEDIAN REBAR)  
#5 REBAR**

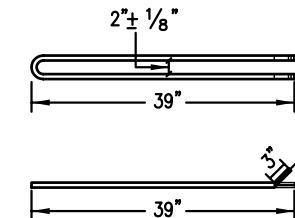

**REPLACEMENT DETAIL**

**Oregon DOT  
Approved Dimensions**

Colorado Department of Transportation  
4201 East Arkansas Avenue  
Denver, Colorado 80222  
Phone: (303) 757-9083 FAX: (303) 757-9820  
Project Development Branch SD

Computer File Information  
Path: www.dot.state.co.us/DevelopProjects/DesignSupport/MStandards/  
Drawing File Name: 6060120101.dwg  
Acad Version: R14 Scale: NA Units: English

Standard Plan Revised	
Date:	Comments:

**PORTABLE  
CONCRETE BARRIER**  
Issued By: Project Development Branch Month Date, 2002

**STANDARD PLAN NO.**  
M-606-12  
Sheet No. 1 of 1