

SECTION B-B

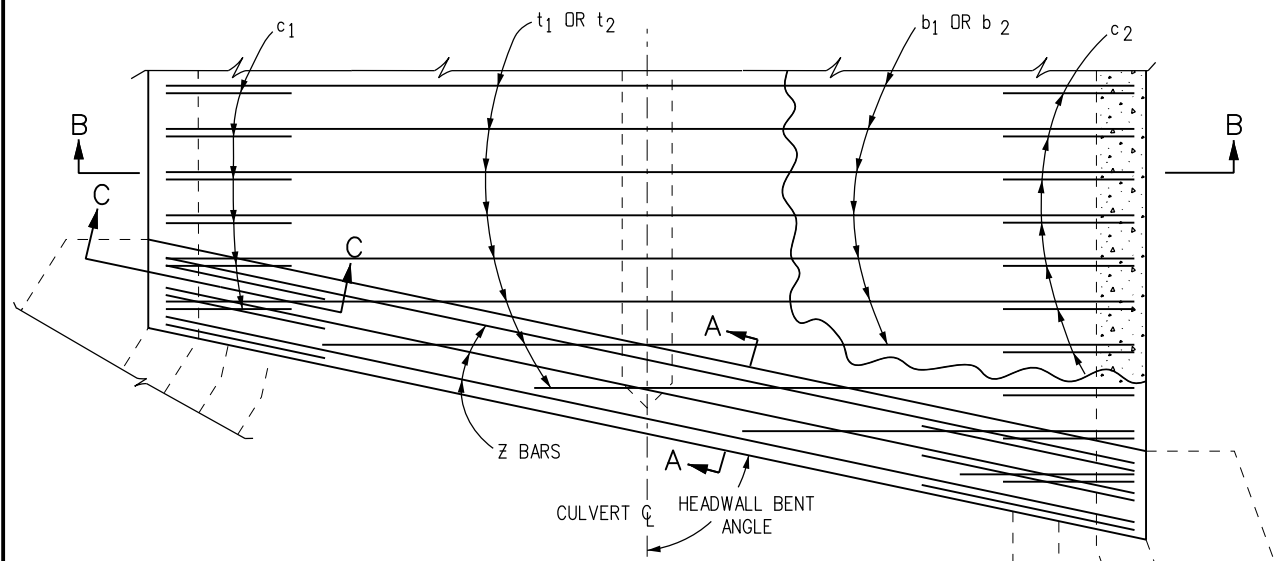

REINFORCING PLAN

BAR SIZE (#)	EPOXY X (FT.-IN.)	BLACK X (FT.-IN.)
4	2-4	1-11
5	2-10	2-4
6	3-5	2-10
7	4-1	3-3
8	5-3	4-3
9	6-8	5-5

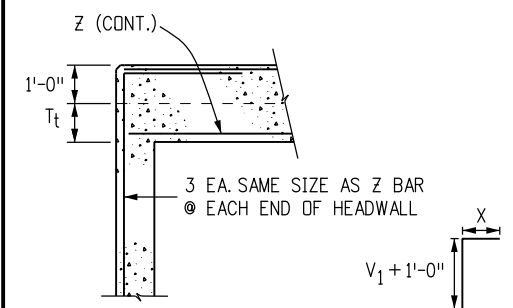

**SECTION C-C
HEADWALL CORNER REINFORCING DETAIL**

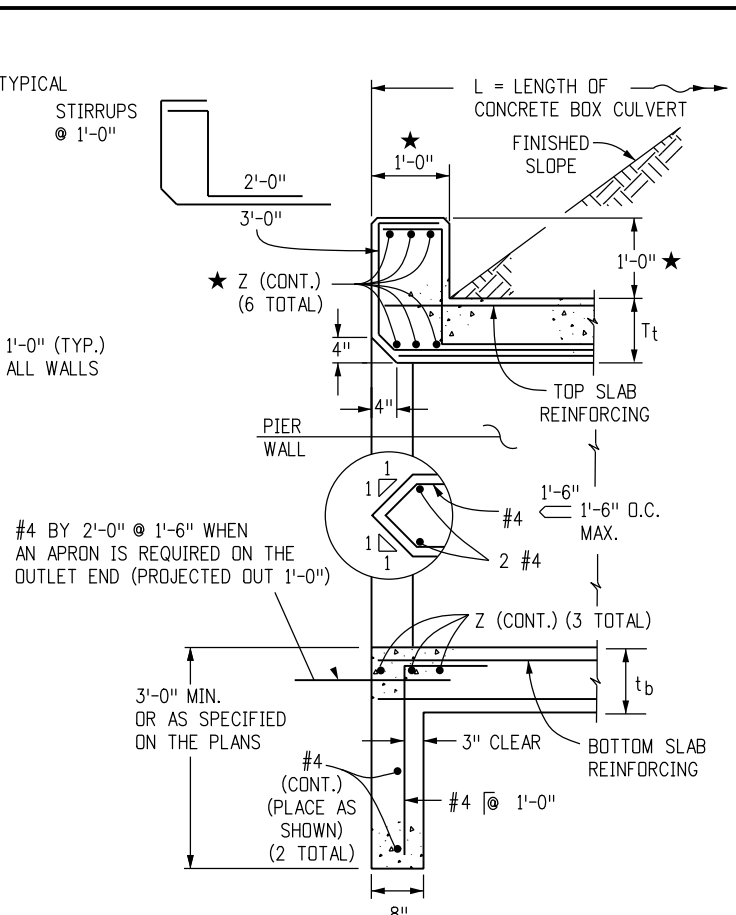

SECTION A-A

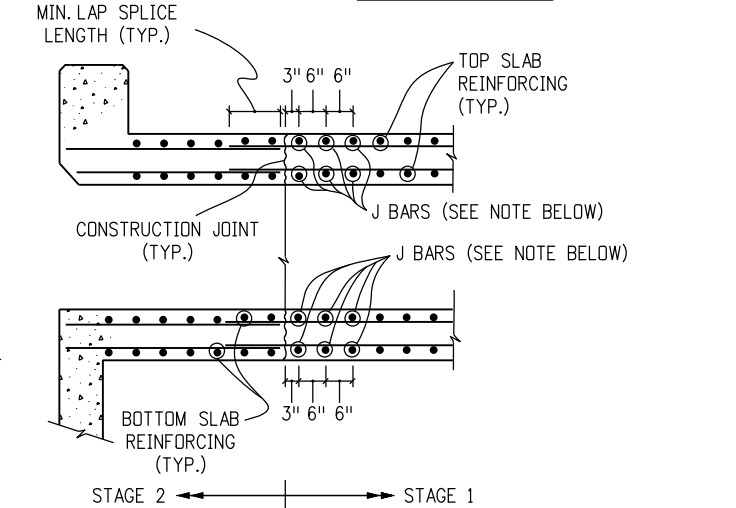

CONSTRUCTION JOINT DETAIL FOR STAGED CONSTRUCTION

NOTE: THIS DETAIL IS FOR CONSTRUCTION JOINTS INSTALLED PERPENDICULAR TO THE C OF THE BOX ONLY. THE CONTRACTOR CAN DESIGN AND INSTALL J BARS AT HIS EXPENSE TO SUPPORT TEMPORARY LIVE LOADS DURING STAGE 1 CONSTRUCTION. J BARS SHALL BE THE SAME SIZE AS THE TOP AND BOTTOM SLAB REINFORCING WHEN THERE ARE NO TEMPORARY LIVE LOADS TO SUPPORT.

GENERAL NOTES

1. ALL CONCRETE SHALL BE CLASS D (BOX CULVERT).
2. ALL CONSTRUCTION JOINTS SHALL BE THOROUGHLY CLEANED BEFORE FRESH CONCRETE IS PLACED.
3. ALL CONSTRUCTION JOINTS NOT SHOWN ON THE PLANS SHALL BE CONSTRUCTED ONLY IF APPROVED BY THE ENGINEER.
4. THE CONTRACTOR SHALL MAINTAIN THE STABILITY OF THE STRUCTURE DURING CONSTRUCTION.
5. STRUCTURE EXCAVATION AND BACKFILL SHALL BE IN ACCORDANCE WITH STANDARD PLAN M-206-1.
6. FOR ANY CULVERT SPAN 20 FT. OR GREATER, A FOUNDATION INVESTIGATION AND REPORT ARE REQUIRED.
7. BACKFILL SHALL NOT BEGIN UNTIL TOP SLAB HAS REACHED DESIGN STRENGTH, f_c .
8. SPLICE QUANTITIES FOR LONGITUDINAL AND TRANSVERSE BARS ARE NOT INCLUDED.
9. REINFORCING STEEL SHALL BE GRADE 60.
10. THE MINIMUM LAP SPLICE LENGTH FOR EPOXY COATED REINFORCING BARS SHALL BE:

BAR SIZE:	#4	#5	#6	#7	#8	#9	#10	#11
SPLICE LENGTH:	1'-3"	1'-7"	2'-5"	2'-10"	3'-8"	4'-8"	5'-11"	7'-3"

THE MINIMUM LAP SPLICE LENGTH FOR BLACK REINFORCING BARS SHALL BE:

BAR SIZE:	#4	#5	#6	#7	#8	#9	#10	#11
SPLICE LENGTH:	1'-1"	1'-4"	1'-7"	1'-11"	2'-6"	3'-1"	3'-11"	4'-10"

11. ALL DIMENSIONS ARE PERPENDICULAR TO THE CENTERLINE OF THE BOX.
12. WINGWALLS SHALL BE TIED TO CONCRETE BOX CULVERT IN ACCORDANCE WITH STANDARD PLAN M-601-20.
13. ALL TRANSVERSE REINFORCING SHALL BE NORMAL TO THE CENTERLINE OF THE BOX.
14. THE FILL HEIGHT IS THE DISTANCE MEASURED FROM THE TOP OF THE TOP SLAB TO THE TOP OF PAVEMENT.
15. ALL EXPOSED CONCRETE CORNERS SHALL BE CHAMFERED $\frac{3}{4}$ ".
16. FOR FILL HEIGHTS LESS THAN 2 FT, A WATERPROOFING MEMBRANE SHALL BE PROVIDED FOR THE TOP OF THE TOP SLAB AND 18" DOWN ALONG THE TOPS OF THE EXTERIOR WALLS.
17. FOR FILL HEIGHTS LESS THAN 2 FT, THE d_1 BARS FOR THE BOTTOM MAT OF THE TOP SLAB SHALL BE AS FOLLOWS:

S	6, 8	10, 12, 16	14, 18	20
BAR SIZE:	#4	#5	#6	#7
SPACING	0'-6"	1'-0"	1'-2"	1'-2"

DESIGN DATA: 7TH EDITION, 2014, OF THE AASHTO LRFD BRIDGE DESIGN SPECIFICATIONS
 RATING DATA: 2ND EDITION, 2011, OF THE AASHTO MANUAL FOR BRIDGE EVALUATION

LOADING DATA:
 $f_y = 60,000$ psi,
 $f_c = 4,500$ psi,
 LIVE LOAD = AASHTO LRFD, HL-93 TRUCK, HL-93 TANDEM, COLORADO PERMIT TRUCK AND NRL

DEAD LOAD CASE 1: VERTICAL EARTH LOAD = 120 LBS./CU. FT.
 HORIZONTAL EARTH LOAD = 30 LBS./CU. FT.

DEAD LOAD CASE 2: VERTICAL EARTH LOAD = 120 LBS./CU. FT.
 HORIZONTAL EARTH LOAD = 60 LBS./CU. FT.

WEARING SURFACE - 12 IN. THICK CONCRETE PAVEMENT.
 DEAD LOAD - TYPE 7 BARRIER.
 THRUST IS NOT CONSIDERED IN THIS STANDARD, I.E. THRUST = 0.

EXTREME HEADWATER TO DEPTH RATIO IS IN ACCORDANCE WITH THE CDDT DRAINAGE MANUAL.
 EXTREME HEADWATER TO DEPTH RATIO WAS INCLUDED IN THE CULVERT DESIGNS BUT EXCLUDED FROM THE RATINGS AS PER THE AASHTO MANUAL FOR BRIDGE EVALUATION.

LIVE LOAD SURCHARGE ON EXTERIOR WALLS = 2 FT. OF EARTH

- ★ IF HEADWALL MOUNT GUARDRAIL IS USED (SEE STANDARD PLAN M-606-1, SHEET 19) AND THE NOTES BELOW:
 - ALL REINFORCING STEEL SHALL BE ACCORDING TO THIS BOX CULVERT PLAN.
 - ANY SPECIAL DESIGN FOR STIRRUPS WILL NOT BE MEASURED AND PAID FOR SEPARATELY BUT SHALL BE INCLUDED IN THE WORK.
 - HEADWALL DIMENSION AND CONCRETE QUANTITY SHALL BE ACCORDING TO STANDARD PLAN M-606-1, SHEET 19.
 - POST ANCHORS SHALL BE PROVIDED ACCORDING TO STANDARD PLAN M-606-1, SHEET 19.
 - POST ANCHORS AND CONCRETE FOR HEADWALL MOUNT OF GUARDRAIL WILL NOT BE MEASURED AND PAID FOR SEPARATELY BUT SHALL BE INCLUDED IN THE WORK.
 - POST ANCHORS WHEN REQUIRED AND ENCASED IN HEADWALL CONCRETE, SHALL CONFORM TO ASTM A 36 OR AASHTO M 169 STEEL.
- 18. SEE M-603-3 FOR PRECAST CONCRETE BOX CULVERT DETAILS.

Computer File Information

Creation Date: 07/04/12	Initials: DDG
Last Modification Date: 04/05/19	Initials: JBE
Full Path: www.codot.gov/business/designsupport	
Drawing File Name: 601020102.dgn	
CAD Ver.: MicroStation V8	Scale: Not to Scale Units: English

Sheet Revisions

Date:	Comments
08/27/13	LRFD Design
08/01/15	Analysis Program Updates
04/05/19	Clarified this sheet is for Cast-In-Place CBC only, not for Pre-Cast CBC. Changed title and added Gen. Note 18.

Colorado Department of Transportation

2829 West Howard Place
 CDDT HQ, 3rd Floor
 Denver, CO 80204
 Phone: 303-757-9021 FAX: 303-757-9868

Division of Project Support DDG/Bridge

**DOUBLE CONCRETE BOX
 CULVERT (CAST-IN-PLACE)**

Issued By: Project Development Branch July 4, 2012

STANDARD PLAN NO.

M-601-2

Sheet No. 1 of 2

DOUBLE CONCRETE BOX CULVERT DIMENSIONS, QUANTITIES & RATING FACTORS (EXCLUDING HEADWALL & TOEWALL QUANTITIES)

BOX SIZE				FILL HEIGHT ALLOWED	SLAB & WALL THICKNESS (INCHES)			BAR SIZES						DIMENSIONS					QUANTITIES			RATING FACTORS								
S	R	HT.	WIDTH	FT-FT	T ₁	T ₂	TW & TW ₁	t ₁ *	t ₂	b ₁	b ₂	w ₁ *	w ₂	w ₃ *	w ₄	c ₁ *	c ₂	d ₁ ▲	h ₁	h ₂	v ₁	v ₂	v ₃	CONCRETE	REBAR STL	MEMBRANE	HL-93 INVENTORY	HL-93 OPERATING	COLORADO PERMIT	NRL VEHICLE
FT	FT	FT-IN	FT-IN	FT-FT	FT	FT	FT	#	#	#	#	#	#	#	#	#	#	NO.	FT-IN	FT-IN	FT-IN	FT-IN	FT-IN	CY/LF	LBS/LF	CY/LF				
6	6	7-9	14-6	< 2	11	10	10	5	6	5	6	4	4	5	5	114	3-5	2-4	6-8	3-1	1-11	1.495	338	1.944	1.27	1.65	2.09	2.05		
		7-7.5	14-6	2 TO 10	10	9.5	10	5	5	5	5	4	4	4	5	5	102	2-6	2-4	6-8	3-1	1-11	1.428	300	1.944	1.81	2.35	2.90	2.82	
		7-7.5	14-6	10 TO 12.8	10	9.5	10	4	4	4	4	4	4	4	5	5	102	2-6	2-4	6-8	3-1	1-11	1.428	258	1.944	4.53	5.88	6.42	7.36	
		7-8	14-6	12.8 TO 20	10	10	10	4	4	4	4	4	4	4	5	5	102	2-6	2-4	6-8	3-1	1-11	1.451	258	1.944	◆	◆	◆	◆	
		9-9	14-6	< 2	11	10	10	5	6	5	6	4	4	4	5	5	126	3-5	2-4	8-8	3-1	1-11	1.681	365	1.944	1.28	1.66	2.10	2.05	
		9-7.5	14-6	2 TO 10	10	9.5	10	5	5	5	5	4	4	4	5	5	114	2-6	2-4	8-8	3-1	1-11	1.613	327	1.944	1.82	2.36	2.85	2.77	
	8	9-7.5	14-6	10 TO 12.8	10	9.5	10	4	4	4	4	4	4	4	5	5	114	2-6	2-4	8-8	3-1	1-11	1.613	285	1.944	4.66	6.04	6.82	5.08	
		9-8	14-6	12.8 TO 20	10	10	10	4	5	5	5	4	4	4	5	5	114	2-6	2-4	8-8	3-1	1-11	1.636	317	1.944	◆	◆	◆	◆	
		11-9	14-6	< 2	11	10	10	5	6	5	6	4	4	4	5	5	138	3-5	2-4	10-8	3-1	1-11	1.866	392	1.944	1.28	1.67	1.00	2.06	
		11-7.5	14-6	2 TO 10	10	9.5	10	5	5	5	5	4	4	4	5	5	126	2-6	2-4	10-8	3-1	1-11	1.799	354	1.944	1.83	2.38	1.00	2.78	
		11-7.5	14-6	10 TO 12.8	10	9.5	10	4	4	4	4	4	4	4	5	5	126	2-6	2-4	10-8	3-1	1-11	1.799	312	1.944	2.22	2.88	2.79	1.96	
		11-8.5	14-10.5	12.8 TO 20	10	10.5	11.5	4	5	4	5	4	4	4	5	5	126	2-6	2-4	10-8	3-2	2-0	2.006	336	1.944	◆	◆	◆	◆	

HEADWALL AND TOEWALL QUANTITIES

HEADWALL BENT ANGLE	90° TO 75°			74° TO 60°			59° TO 45°			
	CLEAR SPAN (S)	Z	STIRRUPS	REBAR QUANT.	Z	STIRRUPS	REBAR QUANT.	Z	STIRRUPS	REBAR QUANT.
	#	#	LBS/LF	#	#	LBS/LF	#	#	LBS/LF	
6	4	4	20.8	4	4	20.4	6	4	31.2	
8	4	4	19.9	5	4	24.3	7	4	36.2	
10	5	4	25.0	6	4	30.6	9	4	57.8	
12	6	4	30.0	6	4	29.6	9	5	61.3	
14	6	4	29.7	7	4	35.7	★	★	★	
16	6	4	29.0	8	5	46.7	★	★	★	
18	7	4	35.0	9	5	54.9	★	★	★	
20	7	4	34.4	★	★	★	★	★	★	

CONCRETE QUANTITY = 0.086 CY/LF

NOTES

- SIX INCH SPACING AT EACH END OF THE SPAN FOR A DISTANCE OF 1/4 OF THE SPAN LENGTH; 12 INCH SPACING ELSEWHERE.
- QUANTITIES ARE GIVEN FOR ONE HEADWALL AND ONE TOEWALL AND ARE BASED ON PER LINEAR FOOT OF HEADWALL. STEEL QUANTITIES INCLUDE ALL REINFORCING. QUANTITIES SHALL BE PAID FOR AS SHOWN ON THE PLANS.
- ★ SKEWED HEADWALLS ARE NOT RECOMMENDED FOR THESE SPANS. A SPECIAL DESIGN IS REQUIRED.
- FOR HEADWALL AND TOEWALL DETAILS SEE M-601-2, SHEET 1 OF 2.
- WHEN THE FILL HEIGHTS ARE LESS THAN OR EQUAL TO 2 FT, ALL REINFORCING BARS IN THE HEADWALL, ALL REINFORCING BARS DESIGNATED BY AN ASTERISK (*), AND THE d₁ BARS IN THE TOP MAT OF THE TOP SLAB SHALL BE EPOXY COATED.
- REINFORCING QUANTITIES INCLUDE BOTH EPOXY-COATED AND UNCOATED BARS.
- WHEN A (RISE) R OF LESS THAN 6 FT IS REQUIRED, USE THE BAR SIZES AND THE SLAB AND WALL THICKNESSES FOR THE 6 FT RISE (IF AVAILABLE ON THE TABLE).
- ▲ FOR SIZE AND SPACING OF THE BOTTOM MAT BARS IN THE TOP SLAB SEE TABLE ON M-601-2, SHEET 1 OF 2. ALL OTHER d₁ BARS ARE #4'S AT 1'-0" SPACING. THE NUMBER OF BARS REQUIRED IS LISTED ON THIS SHEET AND INCLUDES BOTH #4 BARS AND THOSE FROM THE TABLE.
- ◆ LIVE LOAD IS NEGLECTED AS PER AASHTO LRFD SECTION 3.6.1.2.6. FOR THESE STRUCTURES REFER TO THE CDDT RATING MANUAL.
- FOR ALL NEW CULVERT DESIGNS, A RATING IS REQUIRED. THE RATING SUMMARY SHEET SHOULD BE PRINTED FROM THE CDDT EXTERNAL WEBSITE AND SUBMITTED TO THE BRIDGE RATING UNIT OR INCLUDED AS PART OF A LARGER DESIGN PACKAGE. FOR ADDITIONAL INFORMATION, SEE THE CDDT RATING MANUAL.

Computer File Information

Creation Date: 07/04/12 Initials: DDG
 Last Modification Date: 04/05/19 Initials: JBE
 Full Path: www.codot.gov/business/designsupport
 Drawing File Name: 601020202.dgn
 CAD Ver.: MicroStation V8 Scale: Not to Scale Units: English

Sheet Revisions

Date:	Comments
08/27/13	LRFD Design
08/01/15	Analysis Program Updates
04/05/19	Clarified this sheet is for Cast-In-Place CBC only, not for Pre-Cast CBC. Changed title and added Gen. Note 18.

Colorado Department of Transportation

2829 West Howard Place
 CDDT HQ, 3rd Floor
 Denver, CO 80204
 Phone: 303-757-9021 FAX: 303-757-9868

Division of Project Support DDG/Bridge

DOUBLE CONCRETE BOX CULVERT (CAST-IN-PLACE)

Issued By: Project Development Branch July 4, 2012

STANDARD PLAN NO.

M-601-2

Sheet No. 2 of 2