

APPENDIX A EXAMPLE 5 - EXPANSION DEVICE (STRIP SEAL) 0 - 4 INCH

GENERAL INFORMATION

Assuming a 340-ft multi-span, precast, prestressed BT63 girder superstructure with a 20 deg. skew, determine the range of movement for a 0-4 inch expansion device due to temperature, creep, and shrinkage. Specify the installation gap sizes for temperatures ranging from -30 °F to 120 °F, at 10 degree increments, for placement in the expansion device construction drawing. The following example is in accordance with AASHTO LRFD 7th Edition Section 14.5. Refer to CDOT Bridge Design Manual (BDM) Section 14 for additional information and movement considerations. Assume temperature movements conform to AASHTO 3.12.2.2 Procedure B. Stiffnesses in the supporting elements may affect thermal length contribution and may not be symmetrical, this example assumes the stiffness in supporting elements are symmetrical. The 340-ft length includes the approach slabs.

PROJECT VARIABLES

Bridge Properties

Superstructure Type	Bridge	Concrete	
Expansion Length	L =	170.00	ft
Skew	Skew =	20	°
Thermal Coefficient	$\alpha =$	6.0E-06	in./in./°F

Measured from a line normal to bridge \perp
AASHTO 5.4.2.2

Creep and Shrinkage

Total Creep and Shrinkage Strain	$\epsilon_{CR\&SH} =$	0.0002	in./in.	AASHTO 5.4.2.3.2 & AASHTO 5.4.2.3.3
----------------------------------	-----------------------	---------------	---------	--

Temperature Range

Maximum Temperature	$T_{max} =$	110	°F	AASHTO F3.12.2.2-1
Minimum Temperature	$T_{min} =$	-10	°F	AASHTO F3.12.2.2-2
Strength Load Factor, TU	$\gamma_{TU} =$	1.20		AASHTO 14.5.3.2 & T3.4.1-1

Expansion Device Dimensions

Cold Temperature Opening	$A_C =$	4.00	inch	Maximum recommended gland opening
Hot Temperature Opening	$A_H =$	0.50	inch	Minimum recommended gland opening
Minimum Installation Opening	$A_i =$	1.50	inch	Required for placement of gland
Rail Width (min.)	E =	1.25	inch	CDOT B-518-1

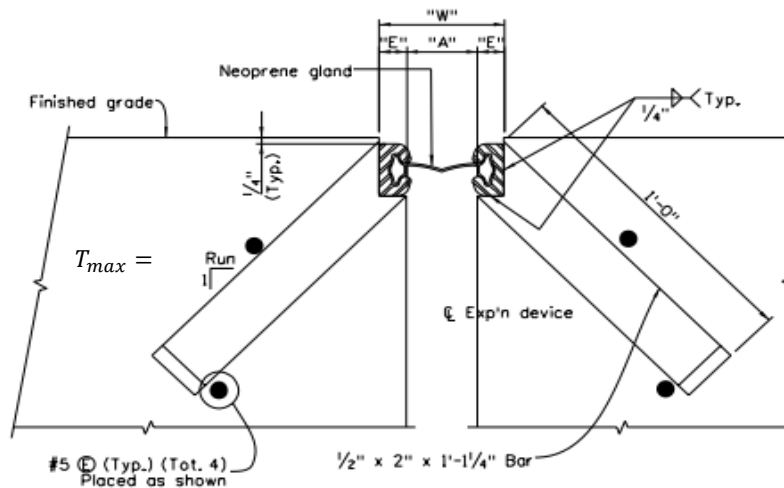

FIGURE 1 - BRIDGE EXPANSION DEVICE (0 - 4 INCH)

SOLUTION

For demonstration, the following solution assumes a structure temperature of 60 °F at the time of expansion device installation. The Designer shall determine "A" and "W" for the additional installation temperatures accordingly as shown in the completed table below.

$$T_i = \text{60} \text{ } ^\circ\text{F}$$

The total horizontal joint movement shall not exceed the maximum manufacturer recommended joint opening:

$$HM = L(\gamma_{TU}\Delta T\alpha + \epsilon) \cos(\text{Skew}) = (170.00)*(12)[1.20*(110.00-(-10.00))*6.0\text{E-}06+0.0002]\cos(20.00)$$

$$HM = 2.04 \text{ in.} < 4.00 \text{ in.} \quad \text{OK}$$

Maximum cold temperature fall if installed at T_i :

$$\Delta T_C = T_i - T_{min} = 60 - (-10) = 70 \text{ } ^\circ\text{F}$$

Maximum hot temperature rise if installed at T_i :

$$\Delta T_H = T_{max} - T_i = 110 - (60) = 50 \text{ } ^\circ\text{F}$$

Maximum superstructure contraction (joint expansion) caused by a fall in temperature from T_i :

$$A_{expn} = L(\gamma_{TU}\Delta T_C\alpha + \epsilon) \cos(\text{Skew}) = (170.00)*(12)[1.20*70.00*6.0\text{E-}06+0.0002]\cos(20.00)$$

$$A_{expn} = 1.35 \text{ in.}$$

Maximum superstructure expansion (joint contraction) caused by a rise in temperature from T_i :

$$A_{cont} = L(\gamma_{TU}\Delta T_H\alpha - \epsilon) \cos(\text{Skew}) = (170.00)*(12)[1.20*50.00*6.0\text{E-}06-0.0002]\cos(20.00)$$

$$A_{cont} = 0.31 \text{ in.}$$

Check that the factored cyclic joint movement does not exceed 3.50 in. per BDM 14.4.4

$$\Delta_{cyclic} = A_{expn} + A_{cont} = 1.35 + 0.31 = 1.66 \text{ in.} < 3.50 \text{ in.} \quad \text{OK}$$

Dimension "A" at the given installation temperature needs to accommodate the hot and cold temperature movement ranges within the capabilities of the 0-4 in. joint.

The maximum opening the joint is allowed at the installation temperature is the recommended maximum opening minus the maximum joint expansion under cold temperatures.

$$A_{max} = A_C - A_{expn} = 4.00 - 1.35 = 2.65 \text{ in.}$$

The minimum opening the joint is allowed at the installation temperature is the recommended minimum opening plus the maximum joint contraction under hot temperatures.

$$A_{min} = A_H + A_{cont} = 0.50 + 0.31 = 0.81 \text{ in.}$$

The "A" dimension is determined as the value midway between A_{max} and A_{min} . The "A" value specified in the plans should be at least the minimum gland opening required for installation. If the temperature is too warm, causing a narrow joint opening, waiting for a drop in the air temperature is an option prior to gland installation.

$$A = \frac{A_{max} + A_{min}}{2} = \frac{(2.65 + 0.81)}{2} = 1.73 \text{ in.}$$

Check $A \geq A_i = 1.73 \text{ in.} > 1.50 \text{ in.}$ OK

The "W" dimension specified in the plans shall be the total width of the expansion device, measured as the gland opening "A" plus the two rails on either side, E

$$W = 2E + A = 2*1.25 + 1.73 = 4.23 \text{ in.}$$

Comprehensive Expansion Device Table

Air Temp. T_i (°)	ΔT_C (°)	ΔT_H (°)	A_{max} (in)	A_{min} (in)	"A"	"W"
-30	-20	140	3.89	2.05	2.97	5.47
-20	-10	130	3.75	1.91	2.83	5.33
-10	0	120	3.62	1.77	2.69	5.19
0	10	110	3.48	1.63	2.56	5.06
10	20	100	3.34	1.50	2.42	4.92
20	30	90	3.20	1.36	2.28	4.78
30	40	80	3.06	1.22	2.14	4.64
40	50	70	2.93	1.08	2.00	4.50
50	60	60	2.79	0.94	1.87	4.37
60	70	50	2.65	0.81	1.73	4.23
70	80	40	2.51	0.67	1.59	4.09
80	90	30	2.37	0.53	1.45	3.95
90	100	20	2.24	0.39	1.31	3.81
100	110	10	2.10	0.25	1.18	3.68
110	120	0	1.96	0.12	1.04	3.54
120	130	-10	1.82	Too Small	1.82	4.32

Note "A" dimension is less than required for installation. Wait for drop in structure temperature before installing joint.

The "A" dimension values provided are based on a joint with a minimum opening of 0.5 in. and a maximum opening of 4 in. The Contractor shall adjust the "A" dimension values for joints fabricated with different minimum and maximum opening dimensions accordingly.