

COLORADO DEPARTMENT OF TRANSPORTATION STAFF BRIDGE BRIDGE DETAIL MANUAL	Chapter: 13.2 Effective: October 8, 1986 Supersedes: New
Steel Superstructure Details	

13.2.1 Purpose

These drawings are to present the details of the structural steel required by the fabricator and contractor for construction of the structure.

13.2.2 Responsibility

The drawings shall be prepared and checked in the design unit. The graphic presentation of the information shall be the responsibility of the individual preparing the drawing.

13.2.3 Structural Steel (General)

The grades of structural steel usually used for highway structures are:

- (a) AASHTO M-183 (ASTM A-36) is used for all steel fabrication unless otherwise noted.
- (b) AASHTO M-223 (ASTM A-572) is higher strength than AASHTO M-183.
- (c) AASHTO M-222 (ASTM A-588) is higher strength than AASHTO M-183. Considered corrosion resistant, it does not require periodic painting.

The above structural steels are available in the following basic designations:

(a) Rolled shapes, some of which are:

- | | | |
|----|--------------------------------|---------------|
| 1. | W Shape (wide flange) | W 24 X 76 |
| 2. | S Shape (I beam) | S 24 X 100 |
| 3. | Channel | C 12 X 20.7 |
| 4. | Angles (equal and unequal leg) | L 6 X 4 X 5/8 |
| 5. | HP Shape (piling) | HP 12 X 53 |
| 6. | Structural Tee | WT 12 X 38 |

13.2.3 Structural Steel (General) (Continued)

In the previous examples (except angles), the letters designate the shape, the first number designates the nominal depth in inches, and the second number, the weight in pounds per foot.

(b) Plates (PL 1/2 X 36)

For highway structures, plates will generally be flat rolled stock over eight inches wide and 1/4 inch or more thick. Edges of members designated as plates will be assumed to be cut. Plate is generally available in widths up to 200 inches with thickness in the following increments:

1/32 in. from 1/4 in. to 1/2 in.

1/16 in. from 1/2 in. to 1 in.

1/8 in. from 1 in. to 3 in.

1/4 in. over 3 in.

(c) (Bar 6 X 1/2)

For highway structures, bars will generally be flat rolled stock eight inches and less in width and 1/4 inch or more thick. Edges of member designated as bars will be assumed to be rolled. Bar stock is generally available in 1/4 inch increments in width and 1/8 inch increments in thickness.

13.2.4 Welding

Welding is the fusion or uniting of two pieces of metal by application of heat and the addition of filler metal of a composition similar to the pieces being joined. For highway structures, the heat is applied by an electric arc, and the weld metal is deposited into the work from an electrode.

The processes usually used include:

13.2.4 Welding (Continued)

- (a) Manual Shielded Metal Arc: Used for small jobs and field welding, uses an arc between the work and a coated electrode moved manually along the work.
- (b) Submerged Arc: Used for most long, continuous shop welds. Uses an arc between the work and a bare wire electrode moved by automatic or semi-automatic methods. The arc is shielded by means of a granular flux placed loosely around the electrode.
- (c) Gas metal Arc: Similar to submerged arc but uses an inert gas to shield the electrode.

Weld Types:

- (a) Fillet Welds:

Welds of roughly triangular cross section joining surfaces at or approximately at right angles to each other. The joint may be a T-joint, corner joint, or lap joint.

- (b) Groove Welds:

Welds made in a groove between adjacent surfaces or ends of two parts to be jointed. The parts may be arranged for a butt joint, T-joint, or corner joint. The edges of the joint may be square, beveled, V shaped, U shaped, or J shaped on one or both sides. See Fig. 13.2-1.

13.2.5 Welding Symbols

The welding symbols showing welds for highway structures follow the standard as established by the American Welding Society (AWS).

Only a few of many possible combinations will actually be used in the structure details.

The three fundamental parts of a weld symbol are:

13.2.5 Welding Symbols (continued)

- (a) The arrow which points to the seam or joint to be welded. The arrow may appear on either or both ends of the reference line.
- (b) The reference line along which the weld data is placed.
- (c) The basic weld data which indicated the type, size, and extent of the weld required.

A tail showing notes, specifications, or references may be used as required, in addition to the above. If a prequalified weld designation is used in the tail, the basic weld data, (c) above, is not required. Figure 13.2-1 shows the arrangement of items which may be used as part of a welding symbol. All dimensions are given in inches, but the inch marks are deleted.

A brief description of the items follows:

- (a) Size: The depth of preparation for a groove weld or the size of a fillet weld. If no size is shown, complete penetration for a groove weld; or a minimum size for a fillet weld is required.
- (b) Penetration (Effective throat): The depth of weld metal deposited into the material.
- (c) Finish: The method of finish; G (grind), C (chip), etc.
- (d) Contour: The shape of the finished joint.
- (e) Groove Angel: The angle of the groove in the base metal.
- (f) Root Opening: The minimum distance between the pieces to be joined.
- (g) Basic Symbol: Designates the shape of the weld. See Fig. 13.2-1 for example of the more common basic symbols.

Note that vertical portions of the basic symbol appear on the left side.

13.2.5 Welding Symbols (continued)

- (h) Length: The total length of a single weld or the length of an individual weld in a series (stitch weld). If no length is given, the weld is the full length of the joint. In the case where a minimum length of fillet weld is required, such as between the angle and gusset plate in a diaphragm, the weld shall be as shown:

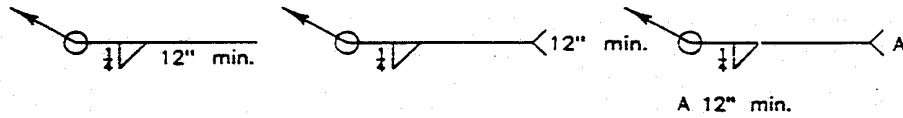

10/08/86

with the length in the tail or on the reference line. A reference letter or number in the tail may be used to indicate a minimum length note elsewhere on the drawing.

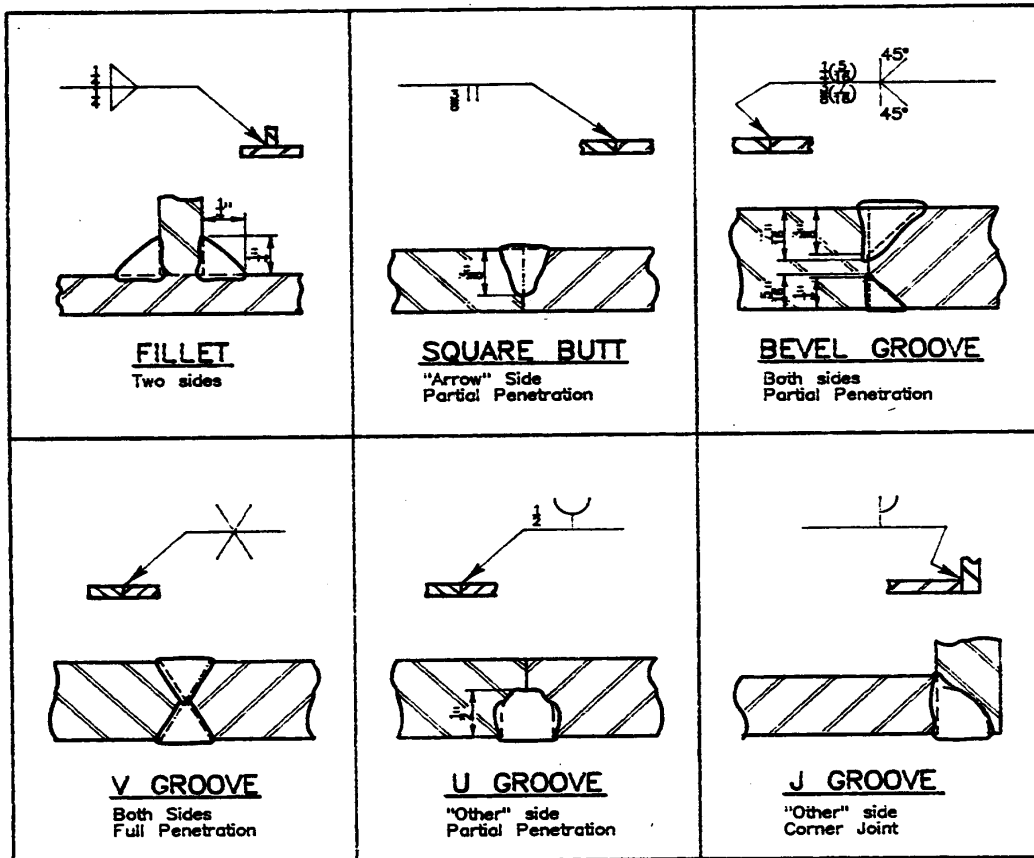
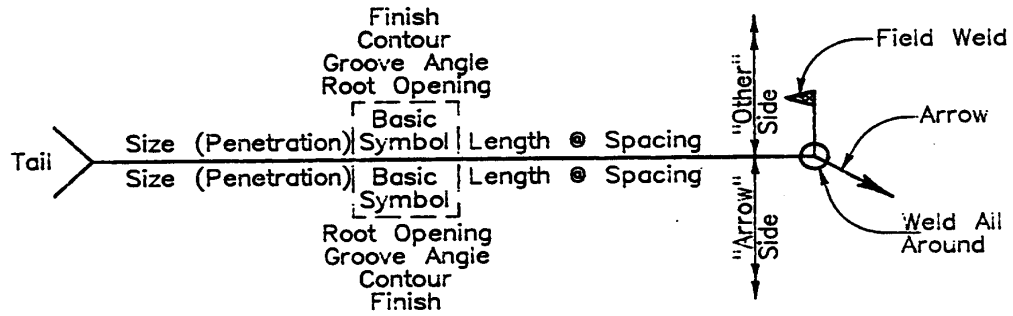

13.2.5 Welding Symbols (continued)

- (i) Field Weld: Designates a weld made in the field. The flag points away from the arrow.
- (j) Weld All Around: The weld shall be continuous between all surfaces of the two parts to be joined.
- (k) Information on either the "Arrow" side or "Other" side of the reference line is valid only for that side of the joint.

13.2.6 Fillet Welds

The major portion of the steel in highway structures will be fillet welded.

Minimum fillet weld sizes shall be determined by the thicker of the two parts shown.

Thickness of Part (in.)	Minimum Fillet Weld (in.)
Through 1/2	3/16
Over 1/2 thru 3/4	1/4
Over 3/4 thru 1-1/2	5/16
Over 1-1/2 thru 2-1/4	3/8
Over 2-1/4 thru 6	1/2
Over 6	5/8

The minimum size seal weld shall be 3/16 fillet weld.

13.2.6 Fillet Welds (continued)

The weld limits for T-joints shall be as shown in Fig. 13.2-2. Note that the condition requiring a single fillet weld should be avoided.

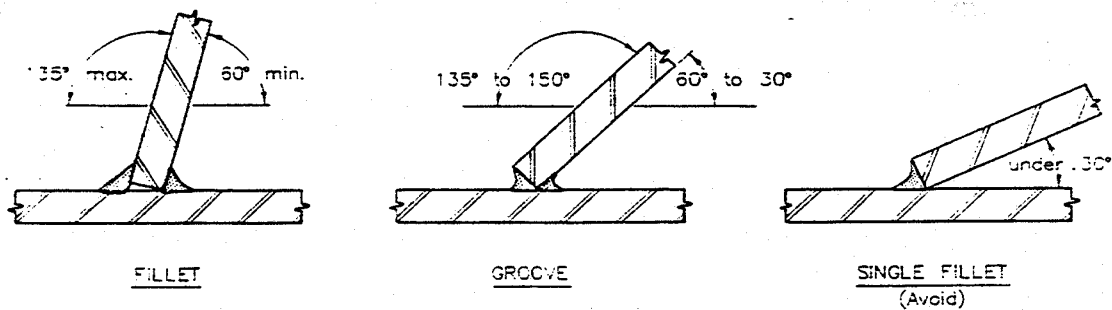

FIG. 13.2-2 T JOINT WELD LIMITS

13.2.7 Field Welds

Field welds are welds made at the job site and are seldom used for new construction. Their primary applications are in repair and widening of existing structures.

13.2.8 Bolted Connections

Most connections between steel parts made in the field will be made using high strength bolts.

The symbol used on the details for a field bolted connection shall be a large solid dot with a note indicating bolt size, if other than the size shown in the General Notes.

13.2.8 Bolted Connections (continued)

The minimum distance from the edge of a part to the center of a bolt shall be as follows:

Bolt Size	Sheared or Flame Cut Edge	Rolled or Planed Edge Except	Flanges of Rolled Beams and Channels
1 in.	1-3/4 in.	1-1/2 in.	1-1/4 in.
7/8 in.	1-1/2 in.	1-1/4 in.	1-1/8 in.
3/4 in.	1-1/4 in.	1-1/8 in.	1 in.
5/8 in.	1-1/8 in.	1 in.	7/8 in.

Maximum edge distance shall be 8 times the thickness of the thinnest outside plate but shall not exceed 5 inches.

Bolt Size	Absolute Minimum	Preferred Minimum
1 in.	3 in.	3-1/2 in.
7/8 in.	2-5/8 in.	3 in.
3/4 in.	2-1/4 in.	2-1/2 in.
5/8 in.	1-7/8 in.	2-1/4 in.

13.2.9 Scales

Scales shall be chosen to give sufficient room for the required dimensions and to fit the detail to the sheet. More than one sheet may be required for Framing Plans and Girder Elevations.

Some suggested scales:

(a) Framing Plan: $1/8" = 1'-0$, $3/16" = 1'-0$, $1/4" = 1'-0"$.

(b) Girder Elevation: Horizontal, $1/8" = 1'-0$, $3/16" = 1'-0"$, $1/4" = 1'-0$. Vertical, $1/4" = 1'-0"$, $3/8" = 1'-0"$, $1/2" = 1'-0"$.

(c) Diaphragms, Stiffeners, Splices, bracing, etc.

13.2.10 Combining Details

Details may be combined on the various sheets as is convenient. The Framing Plan and associated Girder Elevation will usually be shown on the same sheet, as space permits.

Some other possible combinations are:

(a) Diaphragms, Vertical Stiffeners, Lateral Braces

(b) Splices, Longitudinal Stiffeners, Miscellaneous Details

(c) Diaphragms and Splices

(d) Splices and Stiffeners

Details of a similar nature such as diaphragms, splices, or stiffeners should be kept on the same sheet as much as possible.

13.2.11 Framing Plan

(a) The FRAMING PLAN is a diagram showing the location of the following members, as applicable:

1. Girder Webs: Designate as G1, etc. consistently with the "Construction Layout."
2. Diaphragms: The various types of diaphragms should be designated as D1, D2, D3, etc.
3. Splices

13.2.11 Framing Plan (continued)

4. Vertical Stiffeners: Show the location but not the type (S1, S2, etc.). The type will be shown in subsequent details.
5. Lateral Bracing: Show approximate relationship to vertical stiffeners. Dimensions, possibly excepting minimums, will not be required.

b. The following dimensions will be shown on the FRAMING PLAN, as applicable.

1. Girder spacing, centerline to centerline (normal to girders).
2. Centerline girder to centerline girder along centerline of abutment bearing for skewed structures.
3. Spacing of vertical stiffeners. (This may be shown in the girder elevation, if desired, if the spacing is the same for all girders.)
4. Dimensions between diaphragms, or from diaphragms to splices.

c. For long structures, two or more sheets will be needed to provide adequate space for the FRAMING PLAN.

For smaller structures using rolled shapes for girders, the diaphragm spacing may be shown on the CONSTRUCTION LAYOUT and the FRAMING PLAN omitted.

13.2.12 Girder elevation

(a) The GIRDER ELEVATION is an elevation of the girder showing the following, as applicable:

1. Flange plate sizes and lengths.
2. Web plate size and length
3. Shear connector locations.
4. Longitudinal stiffener size and location.
5. Welds

13.2.12 Girder Elevation (continued)

6. Tension and compression areas in the flanges. This will also serve to delineate the areas in which the transverse stiffeners are cut away from the flanges.
- b. The following dimensions shall be shown as applicable:
1. Centerline abutment bearing to centerline abutment bearing.
 2. End of girder to Centerline Abutment Bearing.
 3. Centerline Abutment Bearing to Centerline Splice.
 4. Centerline Splice to Centerline Pier bearing.
 5. Centerline Splice to Centerline Splice.
 6. Flange splice (change in width and/or thickness) to Centerline Splice or Centerline Bearing.
 7. Tension and Compression areas of flange.
 8. Distance from flange to longitudinal stiffener.
 9. Ends of longitudinal stiffener from Centerline Splice or Centerline Bearing if other than the minimum distance.
 10. Dimension as required for cutting varying web dimensions (fish belly).
 11. Dimensions which vary between girders because of curvature, varying bent angles, or other considerations may be shown in tabular form.
- C. A tabulation showing dead load deflections for the girder only, slab only, and total shall be shown with the GIRDER ELEVATION if "Camber and Dead Load Deflection" sheets are not used.

13.2.13 Diaphragm Details

(a) The DIAPHRAGM DETAILS show a plan and elevation view of the diaphragms and crossframes. Complete diaphragm details are not required. The following details show general design features:

1. Size and orientation of member (with acceptable alternates).
2. Thickness of gusset and attachment plates.
3. Size and required length of weld for each typical connection.
4. Correct number of bolts shown for each typical connection.
5. Number, size, and spacing of shear connectors.
6. Location with respect to Girder flange (intermediate diaphragm) or top of deck (end diaphragm).
7. Total depth (intermediate).

(b) Notes to be included with the Diaphragm Details

1. "The intermediate diaphragm bolted connections shall be torqued before the concrete slab has been placed. Holes in gusset plates shall be slotted vertically 1" X 13/16".

(for 3/4" Ø H. S. bolts) (1-1/8" X 15/16" for 7/8" Ø H.S. bolts)
2. Seal remaining contact surfaces between members and gusset plates with 3/16" fillet weld.

13.2.14 Transverse Stiffener Details

The details showing the Transverse (Vertical) Stiffeners shall include an elevation of each different type (usually 3) keyed to the GIRDER ELEVATION.

The following items shall be shown:

- (a) Width and thickness.
- (b) Cutaway dimension from tension flange.
- (c) Clip (cut, snip, chip, etc.) at compression flange.
- (d) Size and location of welds
- (e) Show the longitudinal stiffener if it appears at a given stiffener type.

Holes for diaphragm bolts need not be shown on the stiffener details.

13.2.15 Bearing Stiffener Details

The details for the bearing stiffeners require much the same detail as the transverse stiffeners with the following exceptions:

- (a) The stiffeners are ground to bear or full penetration welded against the bottom flange and welded to the top flange at the ends of the girder.
- (b) Where the girder is continuous over a pier, the stiffener shall be ground to bear or full penetration welded against the bottom flange and tight fit to the top flange.

13.2.16 Lateral Bracing Details

The details for the lateral bracing shall include:

- (a) Member size and orientation with acceptable alternates.
- (b) Gusset plate thickness, orientation, and location.
- (c) Welds
- (d) Bolts
- (e) Call out for minimum practical dimension from stiffeners, splices, other lateral braces, etc.

4

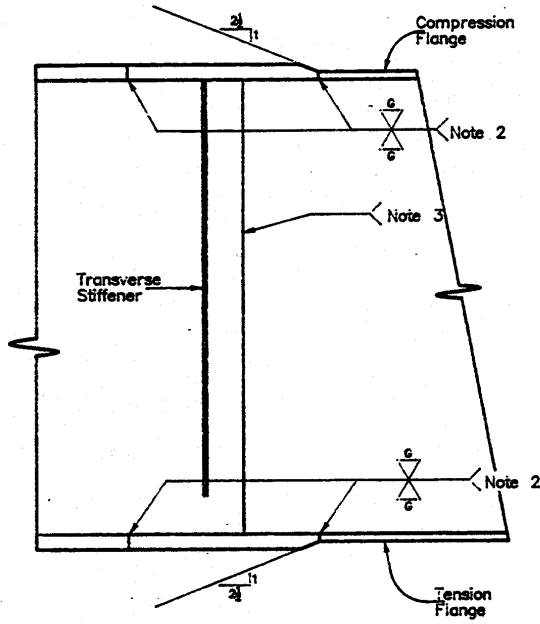

FABRICATION DETAIL

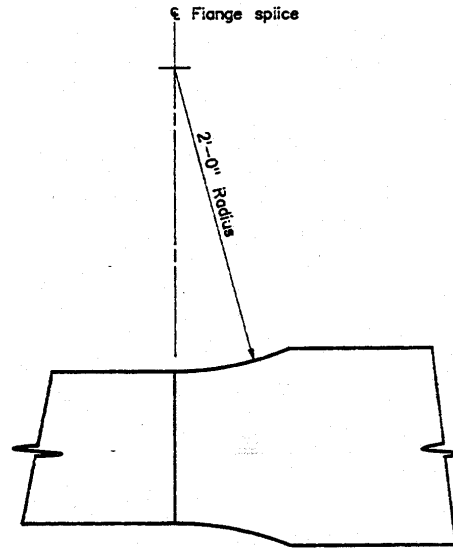

FLANGE WIDTH TRANSITION

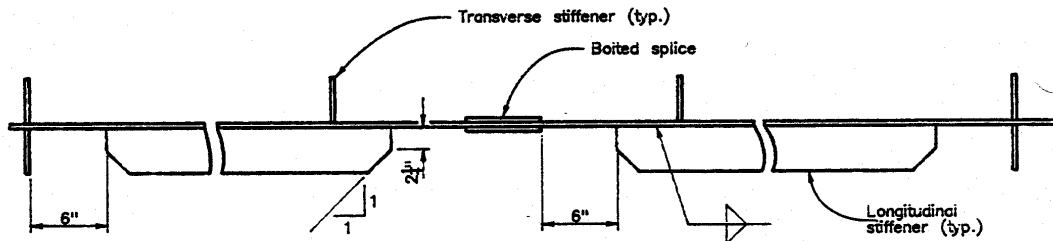

LONGITUDINAL STIFFENER DETAILS

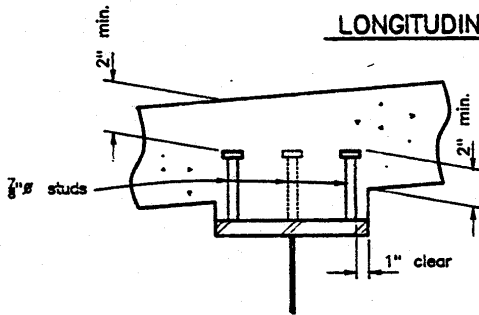

SHEAR CONNECTOR DETAILS

NOTES:

1. Complete web to flange fillet welds after welding flange and web butt welds.
2. Grind all flange butt welds.
3. Web butt joints shall be full penetration groove welds. Where welds on a girder interfere with longitudinal stiffeners, the weld area shall be ground flush.
4. Stiffeners near a field splice may be field welded.
5. Girder ends and bearing stiffeners shall be vertical; except that they may be normal to grade for grades less than 2%.

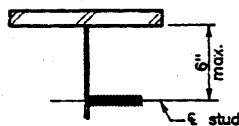

7/8" Ø max. studs to be used for falsework support when specified by the contractor. Contractor to determine size and spacing. Studs shall be removed and ground flush upon removal of falsework.

FALSEWORK SUPPORT

13.2.17 Splice Details

The splice details shall include:

- (a) All plate sizes, including filler plates.
- (b) Bolts spacing and size.

13.2.18 Miscellaneous Details

Figure 13.2-3 shows details which shall be included as applicable:

- (a) FABRICATION DETAIL shall be included for welded plate structures show limitations for various types of web and flange shop splices.
- (b) LONGITUDINAL STIFFENER DETAILS shall be included when the design requires longitudinal stiffeners. The details shall show:
 - 1. Minimum dimension to vertical stiffeners, splices, etc. (usually 6").
 - 2. Shape of end of stiffener
 - 3. Bulk of vertical stiffeners on opposite side of web.
- (c) SHEAR CONNECTOR DETAILS show clearances, minimum, and number and size of stud actually used. A detail or note shall be used to show acceptable alternates.
- (d) FALSEWORK SUPPORT shows size and location of studs used for attachment of concrete forms to the girder. The note is required.
- (e) FLANGE WIDTH TRANSITION is shown when a flange splice is required between plates of varying width.
- (f) FABRICATION NOTES shall be as shown of Figure 13.2-3.

13.2.19 Camber and Dead Load Deflections

This sheet uses the output of the CAMBER computer program to provide the dimensions the shop requires for cutting the girder web so that the structure will conform to the vertical alignment upon completion. The blocking dimensions are used by the shop to assemble the girders in the finished configuration so that the undersized field splice holes will be accurately reamed.

For structures with no skew or horizontal curvature, only one girder need be input with a heading such as "Girders 1 thru 5". Other structures (skewed and/or curved) will require separate input for each girder, unless the skew and curvature (vertical and horizontal) are small.

For a description of the program write-up, see Staff Bridge Design Memo 830-5.

The translucent output (including the dead load deflection) is taped on to blank sheets and handled the same as Bridge Geometry sheets. Title the sheets, "CAMBER AND DEAD LOAD DEFLECTIONS."

13.2.20 Slab

The details for the slab are essentially the same as described elsewhere for other types of structures.

Some points which may require additional attention:

- (a) Special reinforcement may be required, especially in areas where the slab is in tension.
- (b) The outside edges of the deck should be the same thickness as the deck, and the underside of the overhang tapered to the bottom of the top girder flange.

13.2.20 Slab (continued)

- (c) Bottom longitudinal reinforcing in the overhang shall match the curb stirrups as shown on the curb details.
- (d) Haunches between the slab and girder shall be the width of the top flange for composite designs, and extended four inches on each side of the flange for noncomposite designs. The depth of the haunch shall be from the bottom of the slab to the bottom of the top flange and noted on the plans "Haunch varies "_____" at Centerline Bearing and Centerline Girder."
- (e) If expansion devices are required, they will be referred to the Standards Unit.
- (f) An end block detail at the end of the slab will be required for expansion joints. The configuration shall agree with the expansion device details and the detail notes. Title, "SECTION."

Special attention should be given to the placement of the reinforcing near the expansion device.
- (g) For structures on skew where the end diaphragms are not parallel to the end of the slab, the bottom of the end block shall be made a uniform width sufficient to extend over the flange of the end diaphragm.

13.2.21 Bearing Details

Bearings will usually be shown on standard sheets obtained from the Standards Unit. All blanks on the sheet shall be filled in and unnecessary portions removed. A special detail may be required for unusual requirements, hinges in girders, etc.

Clearances between bearing plates and parapets, and girder flanges and parapets, shall be carefully checked. Required cuts on the corners shall be shown in the details. If the cuts are very large, redesign may be necessary.

13.2.22 Railing Details

Railing will usually be shown on standard sheets obtained from the Standards Unit. Special details may be required for architectural considerations, unusual requirements, etc.

13.2.23 Title Blocks

All title blocks and initial blocks shall be filled in on each sheet. The individual drawings shall be titled according to content. Do not use "MISCELLANEOUS DETAILS" unless you mean it.

13.2 Detailing and Checking Procedures

Volume II

PROJECT NO.	SECTION	DATE	BY
RSO133(10)	26		

AS CONTRACTED	REVISION

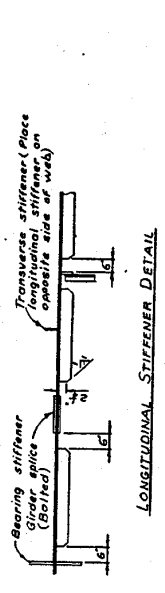
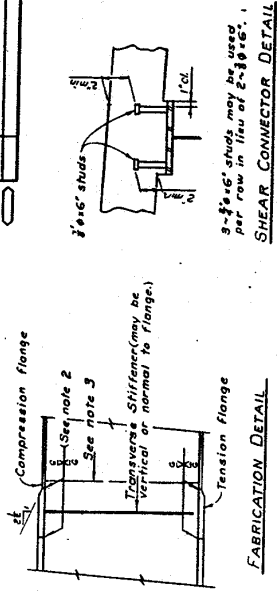

1. DO NOT WELD TO FLANGE FILLER WEBB AFTER WEARING FLANGE
2. GRIND ALL FLANGE BUT WEBS
3. DO NOT WELD TO WEBB
4. WELD WEBS ON A STEEL PARTISSE WITH LONGITUDINAL STIFFENERS. THE WEBS SHALL BE GRIND FLUSH.
5. STIFFENERS WITH A FIELD SPICE MAY BE FIELD WELDED.
6. STIFFENERS WITH WEARING STIFFENERS SHALL BE VERTICAL EXCEPT AS NOTED FOR WEARING TO MAKE THE WEBS LESS THAN 2".

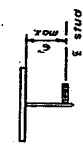

USE 8 WEL. STEEL 6" x 11" WELDER OR WELDER OR FLANGE SUPPORT SHALL SPECIFIED BY THE CONTRACTOR. THE WELDER SHALL BE LOCATED AND GRIND FLUSH WITH WEARING OF FALSEWORK.

SUPPORT FOR FALSEWORK

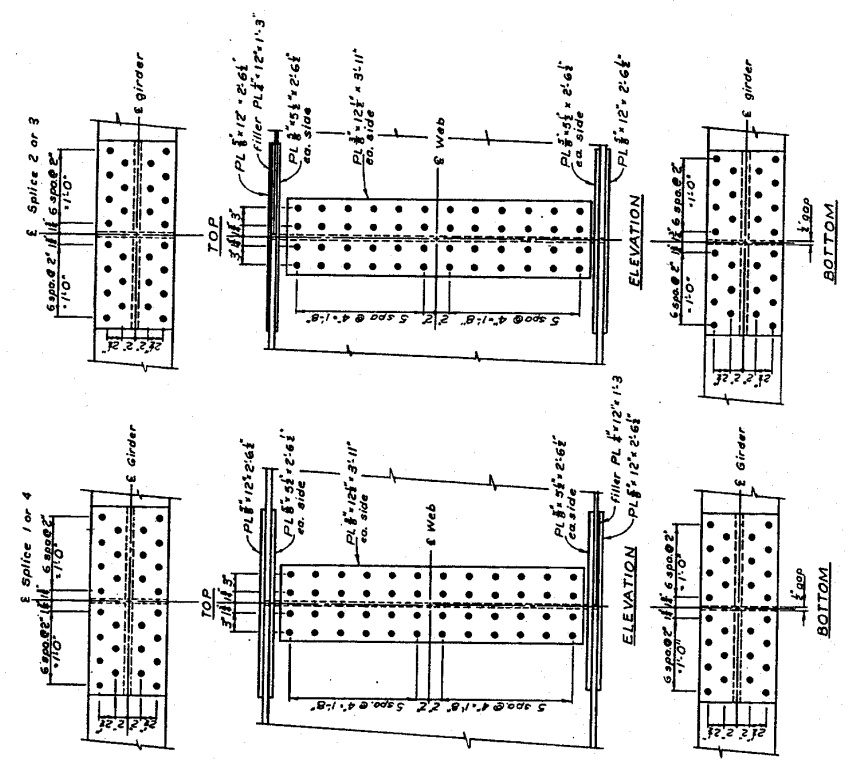

All splice bolts to be 5/8" H.S.

9-15-82

DATE	BY	CHKD	APPD
9-15-82

Fig. 13-2-6

DIVISION OF HIGHWAYS

SPLICE DETAILS
MISCELLANEOUS STEEL DETAILS

Contract No. 257 (12/1/82) Item No. 101-1-1
 Sheet No. 1 of 30
 Drawing Number 101-1-1
 Date 10/1/82
 Drawn by [Name]
 Checked by [Name]

