

Colorado Department of Transportation Staff Bridge Bridge Detail Manual	Chapter: 4 Effective: May 29, 2026 Supersedes: June 30, 2024
---	--

Reinforcing

4.1 Purpose

The purpose of this chapter is to establish a uniform procedure for presenting reinforcing steel in structural details.

4.2 Reinforcing Steel

Bar lists shall not be included in the plans except when required. Bending diagrams shall be included with the details. Bar bending diagrams are preferred and acceptable in complex situations, and when reinforcing is not controlled by concrete dimensions and cover requirements, similar to the bridge rail worksheets.

Reinforcing lengths shall be rounded down to the nearest 1", except when additional accuracy is needed. Dimensions shall be to the nearest 1/4" in these cases.

4.3 Reinforcing Steel Details

Reinforced concrete details shall be drawn in accordance with the designer's notes and current standard practice.

Adequate information shall be shown on each sheet so that the dimensions and shapes of the bars detailed may be readily determined without referring to other detail sheets.

Double line representation should be used when the scale is 1/2"=1' or greater, otherwise use single line representation.

As much of the reinforcing as possible shall be called out in section or sections, and details shown in other views as required to clearly indicate the location of the individual bars. For repeating bars or bar sets, the beginning and ending locations shall be clear.. All reinforcing bends shall be shown with the correct radius. For complex bar arrangements, it may be necessary to draw a detail for each individual mat or portion of reinforcing.

Reinforcing, as a default, will be shown as solid continuous lines but the historical reinforcing linetype or linestyle may be used for clarity as needed.

Bent bars shall be called out with a bending diagram giving dimensions for fabrication. Some examples are:



A bar series is required when the concrete has varying dimensions, e.g.:

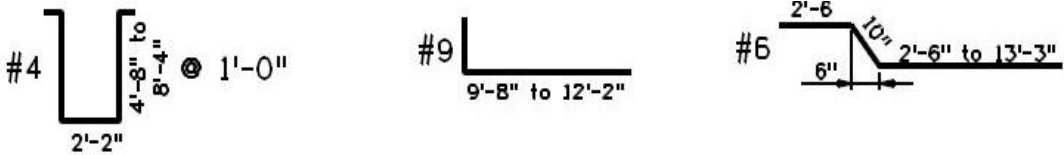

Fig. 4.3-1 Bar Bending Diagrams

All bent bars shall be dimensioned except standard hooks and angles.

Straight bars where the length is controlled by concrete dimensions and end clearances should be called out as, e.g.: #4 Cont @ 1'-0", #6 Cont, #4 (Tot 5).

Straight bars where the length is not controlled by concrete dimensions shall be called out as shown in figures 4.3-2 and 4.3-3 and the bar shall be located with a dimension to its end from easily identifiable locations such as centerline piers, centerline columns, end of pier caps, etc.

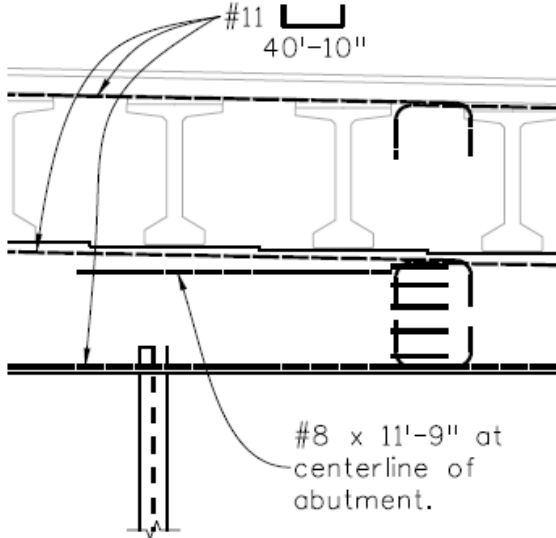

Fig. 4.3-2 Example 1: Rebar not controlled by concrete dimensions

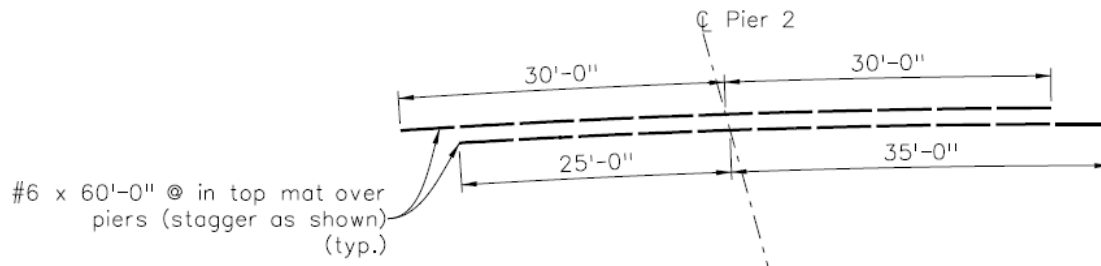

Fig. 4.3-3 Example 2: Rebar not controlled by concrete dimensions

4.4 Non Coated and Epoxy Coated Reinforcing

Reinforcing shall be non coated or epoxy coated, per the Bridge Design Manual. If both non coated and epoxy coated reinforcing is used in the structure, place an N or an E next to the reinforcing which has the fewest number of bars. A note " N denotes non coated reinforcing steel" or " E notes epoxy coated reinforcing steel" shall be added to the general notes.

4.5 Reinforcing Spacing

The designer shall furnish the detailer with the reinforcing bar spacing in the design notes. Bar spacing shall be given in inches or feet and inches.

4.6 Reinforcing Hooks

Unless otherwise noted, standard hooks of 90° , 135° , and 180° will be in accordance with the Specifications and need not be dimensioned on the plans. The designer shall furnish the detailer with the dimensions for non-standard hooks. These dimensions shall be shown on the plans.

4.7 Reinforcing Splices

The minimum splice lengths shall be as shown in the table on worksheet B-100-1, General Information - Summary of Quantities for Class B splices. Non-standard splices or other class splices shall be depicted in the drawing details. These lengths shall not be used if more than $\frac{1}{2}$ of the splices overlap at any one point.

Splice length between bars of different sizes shall be governed by the smaller bar.

Splices for column reinforcing, main longitudinal girder reinforcing, pier cap reinforcing, and stirrup splices shall be detailed on the plans. Splices shall be alternated, staggered, or rotated to prevent rows of splices from being adjacent to each other. Splice locations and lengths shall be shown if these splices are other than minimum lap. Other nominal bars may be indicated as “continuous” without detailing the splice length or location.

Splice locations and quantities shall be determined using 40'-0" lengths for #5 bars and below, and 60'-0" lengths for #6 bars and larger. This does not preclude the use of 60'-0" stock length #4 and #5 bars. Location of splices required by design or construction shall be dimensioned, otherwise splice locations can be considered schematic.

Lapped splices shall not be used for bars larger than #11. For bars larger than #11, mechanical splices or other positive connections shall be used.

To avoid field issues, stirrups for a given element should be made the same length, when possible.

Typical splices shall be drawn as slightly offset lines.



Out of plane bars in section views that overlap shall be shown with offsets.

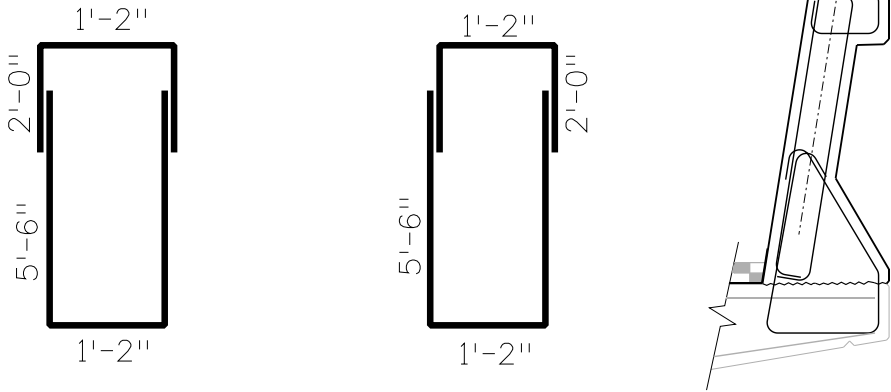

Figure 4.7-1 Bar offset options

4.8 Reinforcing Cover

The minimum cover from the surface of the concrete to the face of any reinforcement bar shall be 2 inches except as listed below:

- Bottom of slab 1”
- Interior surface of box girder webs and diaphragms 1”
- Bottom of lower slab in box girder 1½”
- Stirrups and ties in T-beams 1½”
- Diaphragms designed as T beams 1½”
- Pier caps monolithic with girder webs 1½”
- Top of deck slab with overlay 2”
- Concrete deposited directly against earth 3”

Fit and clearance of reinforcing shall be carefully checked by calculations, full scale drawings, or other accurate means. Allowance shall be made for the deformations (ridges) on the reinforcing steel. Some interference may be acceptable if the bars will fit with minor movement (1/4 bar diameter or less) from the location shown on the plans.

Some common interferences are:

- Between slab reinforcing and reinforcing in abutments and pier caps.
- Vertical dowels projecting through mats of main reinforcing in pier caps and girder stems.
- Reinforcing for expansion devices and deck steel.

Skews will tend to aggravate problems of reinforcing fitting.

4.9 Bundled Bars

Bundled bars shown in the plan and elevation shall be shown as in Fig. 4.9-1.

A note / legend shall be added to clarify the symbol \oslash in the plans.



Figure 4.9-1 Bundled Bars for Plan & Elevation

Bundled bars are shown in a Section View in Figure 4.9-2.

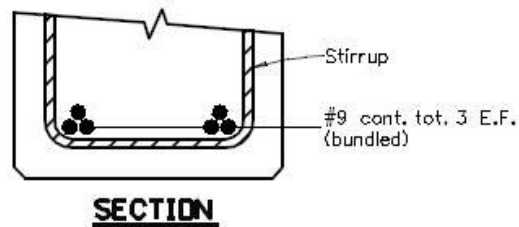

Figure 4.9-2 Bundled Bars in Section

4.10 Dowels

The length of embedment and/or projection for bars used as dowels shall be determined by the designer and shown in the design notes and on the drawings. If bent bars are used for footing dowels, the bends shall be standard hooks and shall rest on the bottom reinforcing mat in the footing.

4.11 Bars in Section

Figure 4.11-1 is a section through a hypothetical member showing some accepted methods for calling out reinforcing steel.

Some observations:

- A) Sections shall be illustrated to a large enough scale to clearly show reinforcing details.
- B) Stirrups and other bars shown in profile shall be drawn with a single bold line at scales below $\frac{1}{2}'' = 1'$. At scales $\frac{1}{2}'' = 1'$ and larger, double line representation shall be used. Hatching or solid representation may be used to clarify the detail. Bar bends shall be drawn to scale with the correct bend radii. See fig. 4.9-2 for example.
- C) Bars shown end-on shall be drawn as filled circles. At scales $\frac{1}{2}'' = 1'$ and larger the filled circles shall be drawn to scale. At smaller scales, the filled circles can be enlarged to clarify the detail. Draw the reinforcing to be dimensionally correct and add enlarged circles on separate levels or in the border sheet so the linework can be used to check for accuracy. Double line reinforcing representation can be drawn in the linework model while single line representation and enlarged circles can be used on a separate level or in the border for depiction purposes.
- D) Arrowheads or circles shall be the preferred method of callout for bars shown end-on. Arrowheads shall point directly to the bar.

- E) For end-on bars, give the bar call out and limiting factors Example: #5 (Between girders).
- F) Sections cut at specific locations along a member will often be preferred over a typical section for complex reinforcing patterns.

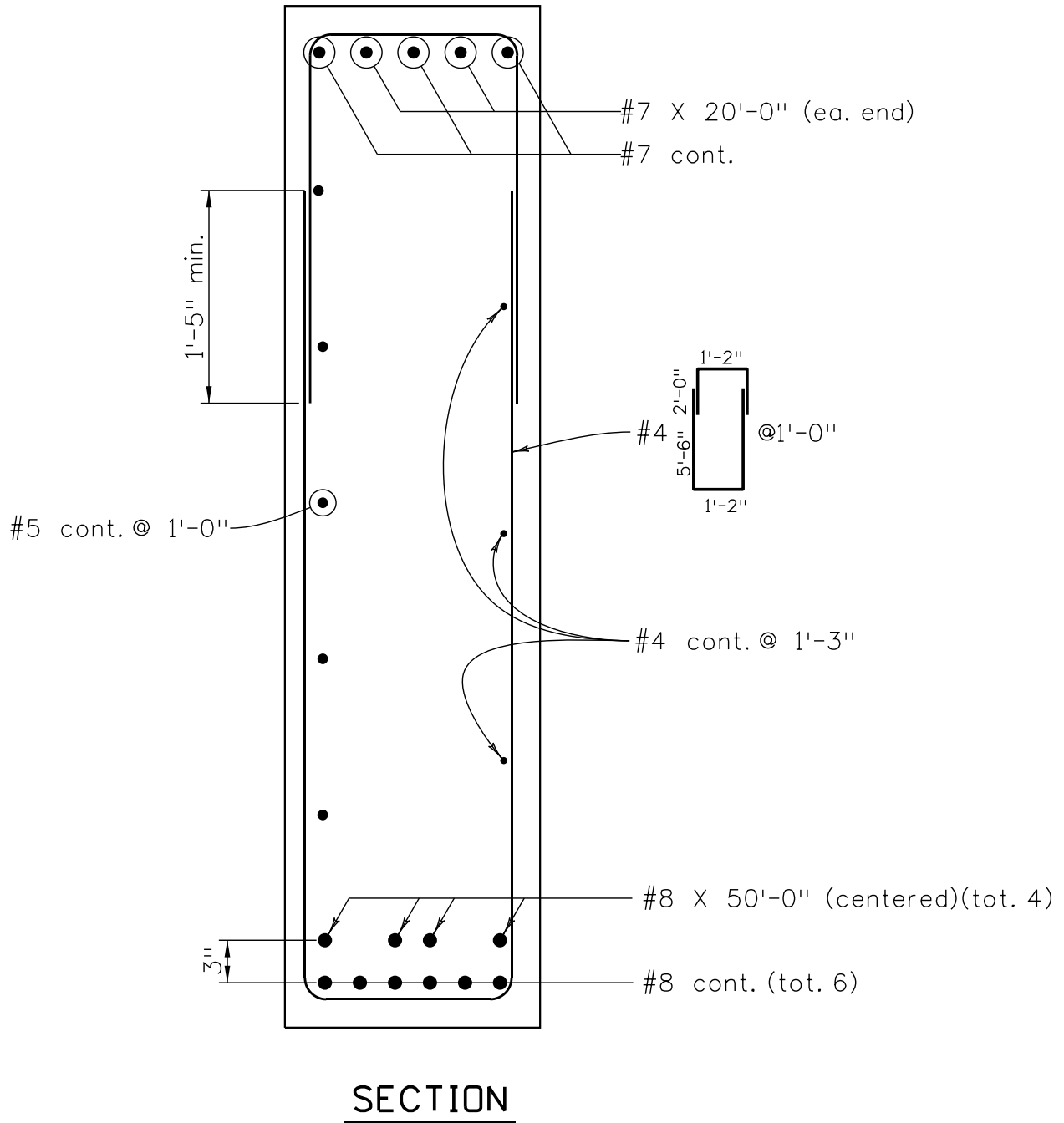

Figure 4.11-1 Bars in Section (Example)

4.12 Reinforcing Quantities

Splice lengths shall be included when determining reinforcing quantities. Estimates or the use of a percentage of the quantities to account for splices will not be acceptable.

Two independent sets of quantities shall be calculated. One set will be prepared by the detailer and one set by the design/detail checker. After differences are resolved, totals from the record set shall be shown on the plans. Extended totals for both sets of quantities shall be within one percent of each other. Quantities from the two independent sets shall not be averaged.

A spread sheet can facilitate quantity calculations. Samples of spread sheets may be found at: <https://www.codot.gov/programs/bridge/bridge-manuals/form-letters>