

Revision Dates	(Preliminary Stage Only)				
5/00	5/01	4/02	9/02	3/07	7/10
					10/13
					3/23

INITIALS	DESIGN	DATE	DETAIL	DATE	QUANTITY	DATE
By						
Checked By						

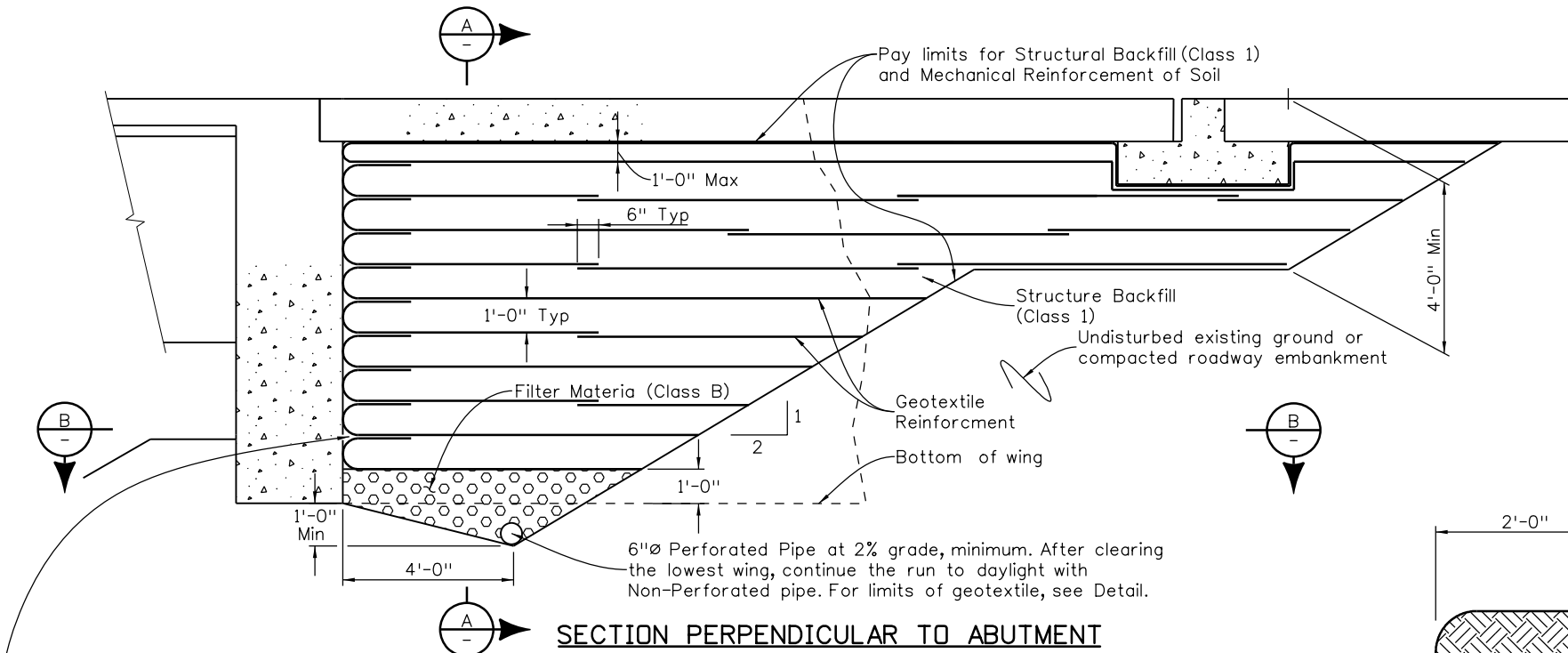

SECTION PERPENDICULAR TO ABUTMENT

For steel structures longer than 300' without expansion devices between abutments and for abutments greater than 12' high, provide gap between the abutment and backfill. The gap width shall be at least 0.5% of the abutment height, 1" minimum. See Gap Detail 1 and 2. Do not provide this gap at bottom 2 nor the top 2 layers of Reinforced Soil.

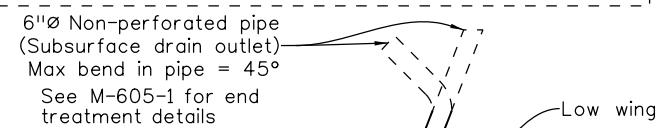

Designer/Detailer:
Discharge into erosion protection (such as riprap or energy dissipators) as needed. Extend and support non-perforated pipe such that a minimum 6" clearance remains below flowline.

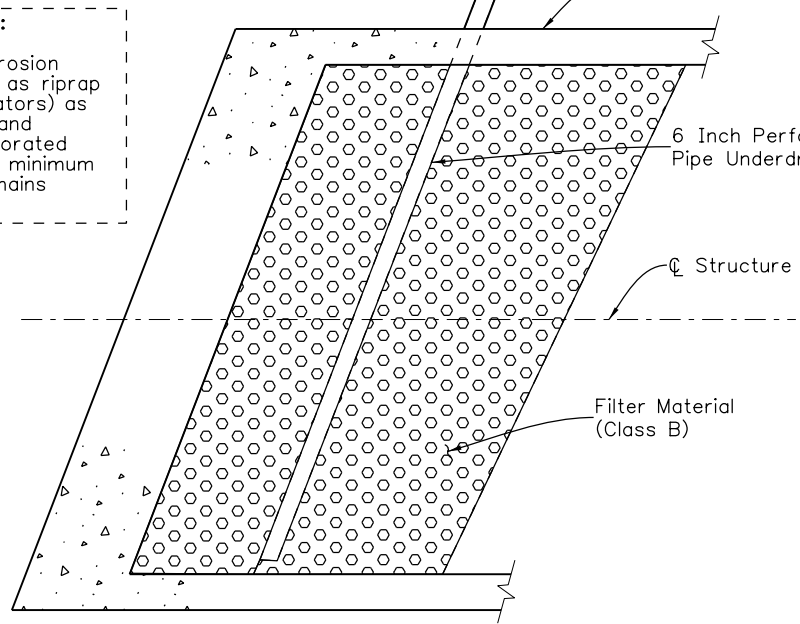

SECTION B

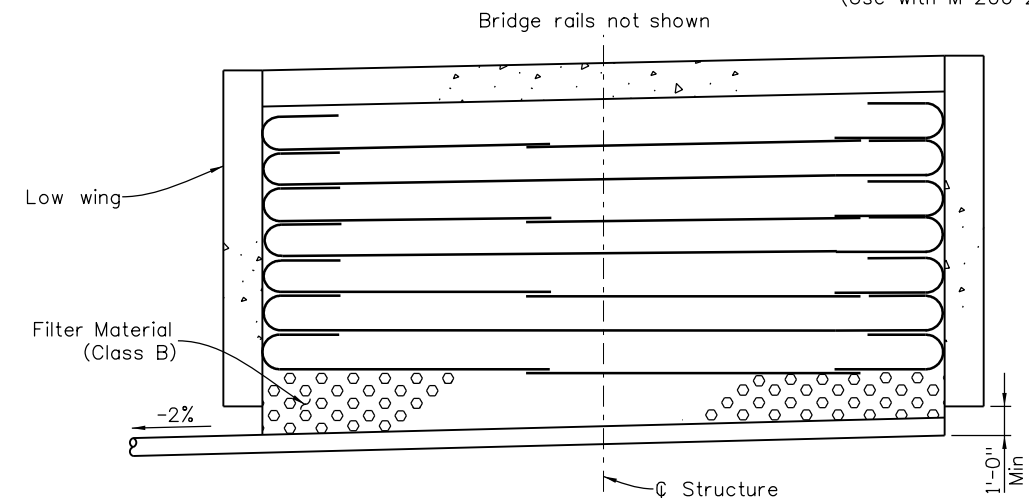

SECTION A

Designer/Detailer: Update to show phasing as required.

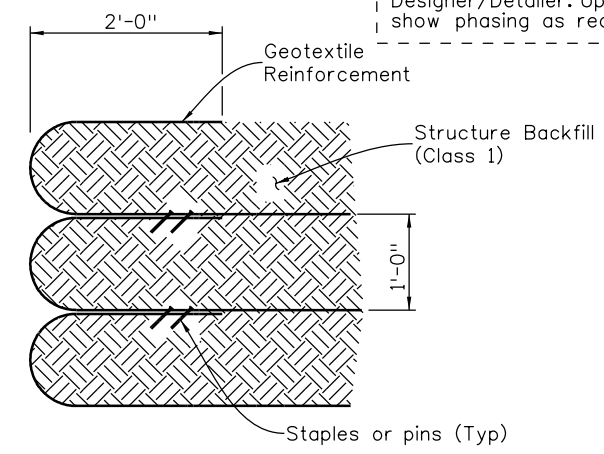

WRAP DETAIL

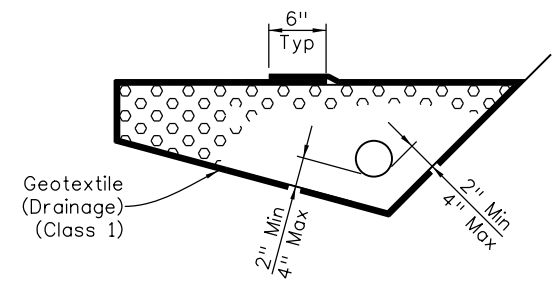

6 INCH PERFORATED PIPE UNDERDRAIN

6 Inch Perforated Pipe Underdrain includes all Filter Material (Class B) and Geotextile (Drainage) (Class 1) surrounding the Filter Material (Class B).

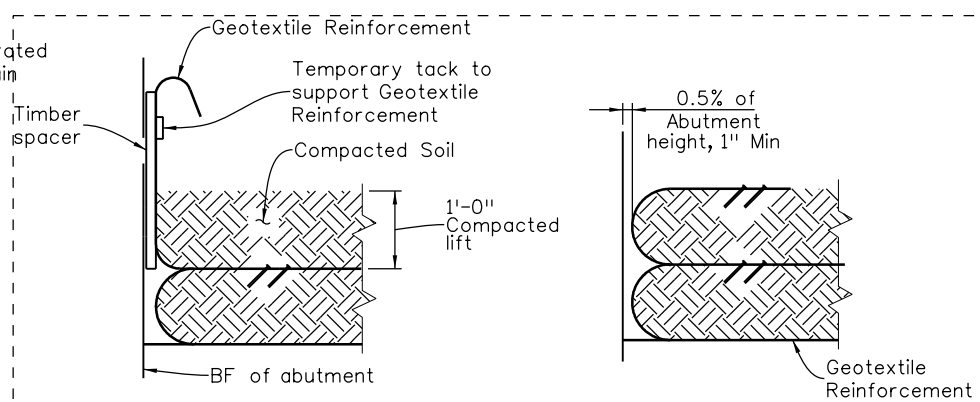

GAP DETAIL STEP 1

GAP DETAIL STEP 2

When required, the Geotextile Reinforcement wrap at Back Face of Abutment shall be temporarily hung with a spacer board and tack strip. After reaching a total of 1'-0" compacted lift, the tack strip shall be removed and textile Reinforcement shall be pulled back slack free with its end anchored to soil underneath with staple or pins before the spacer board is pulled. Any alternate method to maintain the minimum gap between abutment concrete and Reinforced Soil may be proposed to the Engineer for approval.

NOTES:

1. Geotextile Reinforcement shall be woven fabric with a Minimum Average Roll Value of 4800 lb/ft for installations with a gap and 2400 lb/ft for installations without a gap based on ASTM D4595.
2. Geotextile Reinforcement shall be placed by alternating Machine Direction (MD) with Cross Machine Direction (XD) from layer to layer.
3. The Geotextile Reinforcement wrap at Back Face of Abutment shall be pulled back slack free with its end anchored to soil underneath with staples or pins.
4. Minimum splice of all Geofabric shall consist of 6" of overlap.
5. Payment for all work items shown will be made under Item 206 Mechanical Reinforcement of Soil (CY) and Item 206 Structure Backfill (Class 1) (CY) and Shall include the cost for 6 inch \varnothing Perforated Pipe underdrain and Subsurface Drain Outlet (6 inch \varnothing Non-Perforated Pipe).
6. Installation of Pipe Underdrain and Subsurface Drain Outlet will conform to the Construction requirements of Section 605.03 and 605.06, respectively.

All seals for this set of drawings are applied to the cover page(s)	Print Date: \$DATE\$	Sheet Revisions			Colorado Department of Transportation	As Constructed	MECHANICALLY STABILIZED BACKFILL			Project No./Code
	File Name: Sheet_B-206-M1.dgn	Date:	Comments	Init.			No Revisions:	Designer: XXXXXXXX	Structure Numbers: X-XX-XX	
	Horiz. Scale: Not to Scale Vert. Scale: As Noted				2829 West Howard Place, 3rd Floor Denver, CO 80204 Phone: 303-512-4079 FAX: 303-757-9197	Revised:	Detailer: XXXXXXXX	X-XX-XX	Code	
	Unit Information Unit Leader Initials					Staff Bridge Branch	Void:	Sheet Subset: BRIDGE	Subset Sheets: BXX of XXX	Sheet Number



Staff Bridge Branch

Initials