

NOTES:

- Design lengths mentioned below assume a CSG structure type carrying an HS 20-44 loading with an 8" deck and 4" of asphalt.
- Girder working stress reactions relating to span lengths may be different for different structure types. Girder working stress reactions should be verified.
- All bolts and threaded rod shall be A449 high strength steel.
- Grout threaded rod into holes with a non-shrink epoxy grout.
- The Contractor shall verify all dimensions prior to ordering materials.
- Installation and all items shown shall be paid for under Item 512-00120 Bearing Repair Corbel.
- All welding shall be performed per AWS D1.1 with low hydrogen electrodes.

SUGGESTED CONSTRUCTION PROCEDURE

- Remove loose concrete and clean exposed reinforcing steel.
- Bolt the form in place and restore the abutment to its original section using an approved grout (Duracal, etc).
- Allow curing time as recommended by the Manufacturer before removing the form.
- Locate and mark centerline of the girder on the face of the Abutment Bearing Seat.
- Mark location of bolt holes on the abutment, see elevation view and section.
- Drill holes in the abutment and grout bolts in place.
- Cut holes in plywood form to match bolt holes in the abutment.
- Using the form for a pattern, cut the bolt holes in the front plate.
- Attach plates and tighten bolts (100 Lb-Ft torque).
- Raise the support assembly until the elastomeric pad is compressed $\frac{1}{16}$ " (200 psi x pad area = Jacking Force).
- Field weld the support assembly to the front plate.
- Paint all steel as directed by the Engineer.

NOTE TO DESIGNER/DETAILER:

Where one size or dimension is shown, it is good for all designs up to 95 feet.

Where three sizes or dimensions are shown -

No asterisk, For structures with span lengths up to 50 feet (girder working stress reaction = 107 Kip).

* For structures with span lengths up to 80 feet (girder working stress reaction = 154 Kip).

** For structures with span lengths up to 95 feet (girder working stress reaction = 175 Kip).

Delete as needed for your design.

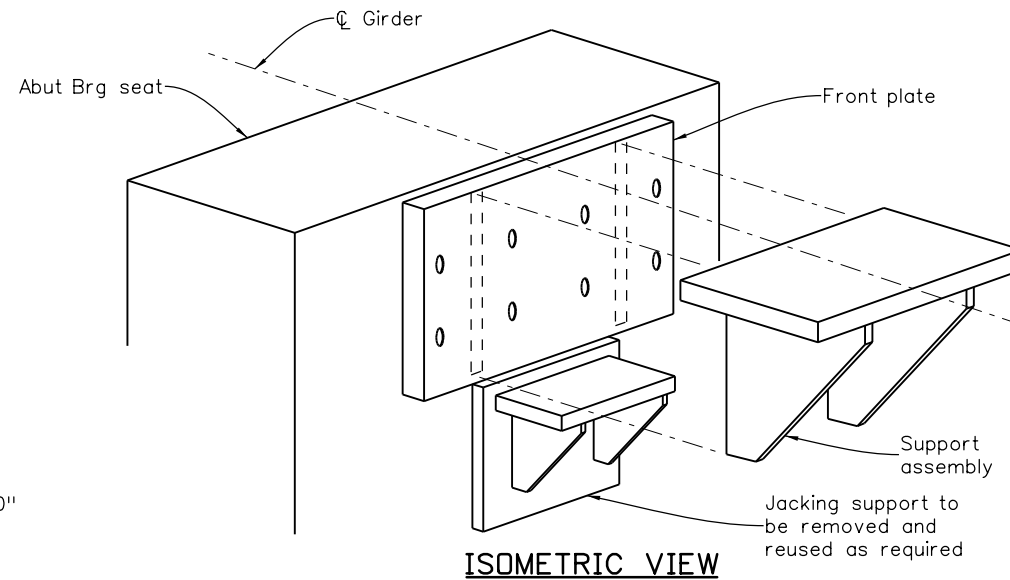

Note to Detailer: Adjust location of Front plate to avoid existing reinforcing (if known) and check weld lengths for sufficient capacity.

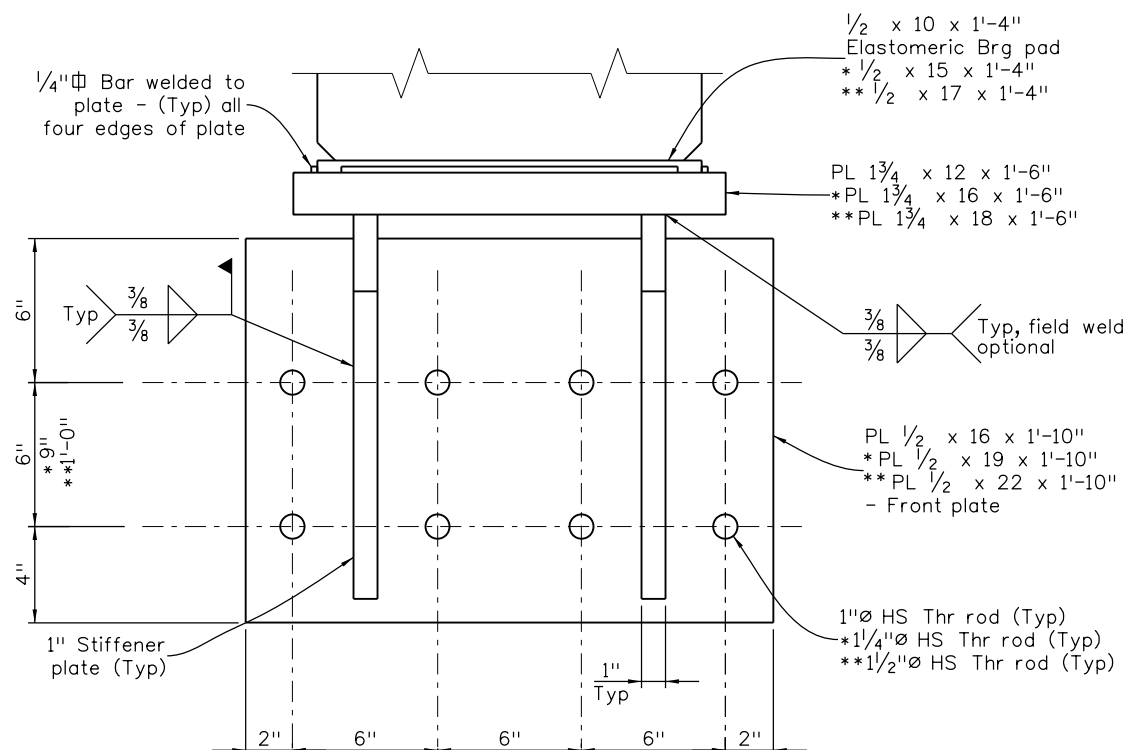
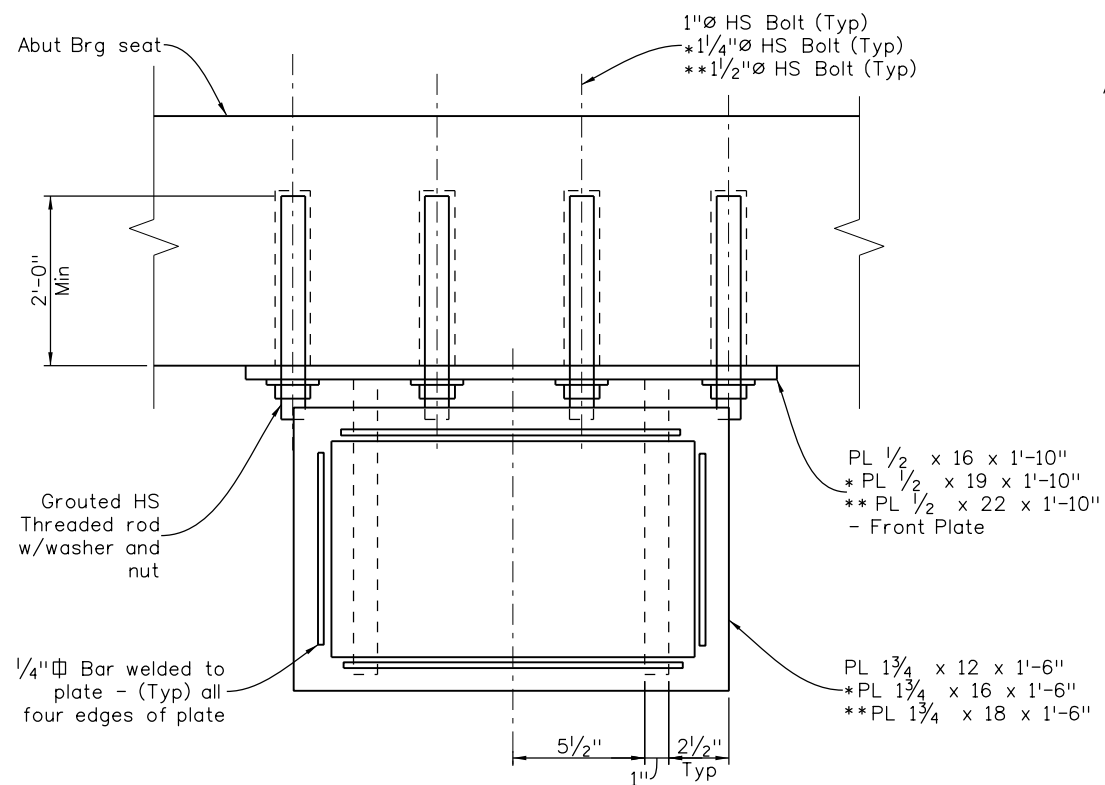
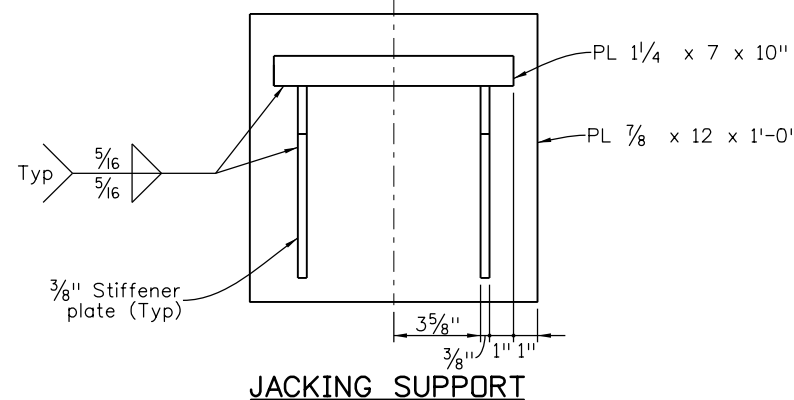
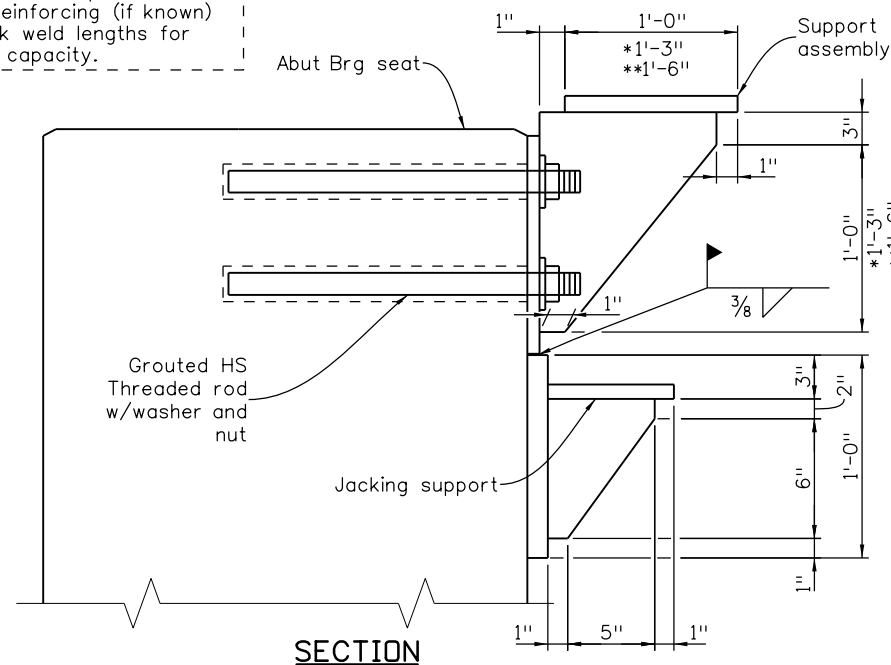

Revision Dates	(Preliminary Stage Only)	3/07	3/23
8/95	3/99	11/99	4/02
9/02	9/02	3/07	3/23

INITIALS	DESIGN	DATE	DETAIL	DATE	QUANTITY	DATE
By						
Checked By						

All seals for this set of drawings are applied to the cover page(s)	Print Date: \$DATE\$	Sheet Revisions			Colorado Department of Transportation		As Constructed		BEARING REPAIR DETAILS			Project No./Code	
	File Name: Sheet_B-509-2A.dgn	Date:	Comments	Init.	2829 West Howard Place, 3rd Floor Denver, CO 80204 Phone: 303-512-4079 FAX: 303-757-9197		No Revisions:		107-175 KIP			Project Number	
Unit Information	Unit Leader Initials				Staff Bridge Branch		Revised:		Designer: XXXXXXXX	Structure Numbers	X-XX-XX		Code
					Initials		Void:		Detailer: XXXXXXXX	Subset Sheets: BXX of XXX	Sheet Number		