

B-606-10MASH A

(Use with B-606-10MASH & 10MASH B)

NOTES:

1. All tubes shall be ASTM A-1085. All posts, base plates, and splice tubes fabricated by welding shall be ASTM A-572 Grade 50. All other steel shall be Grade 36 unless otherwise noted.
2. The above material and all anchor bolts and miscellaneous bolts, nuts, and washers shall be galvanized after fabrication in accordance with Section 509. Concrete, reinforcing steel, and structural steel elements shall conform to the requirements of sections 601 & 606, 602, and 509, respectively unless otherwise noted.
3. All bolts that have lock washers shall be tightened to snug only. All anchors shall be cast in place unless approved by Engineer.
4. The top and inside face of the rail shall receive a coating conforming to Item 515, Concrete Sealer, compatible with the concrete coating or sealer/stain shown in the plans.
5. Payment will be made under item 606, Transition Type BR10M-GR3, for all anchor bolts, miscellaneous bolts, nuts, washers, tubes, tube expansion device, joint filler, expansion joint material, concrete (Class D with macrofiber), reinforcing steel, and concrete sealer. Excavation and backfill will not be paid for separately, but shall be included in the work.
6. Prior to fabrication of this item, an electronic pdf which complies with the requirements of section 105, shall be submitted to the Engineer for information only.
7. All longitudinal reinforcement shall terminate with standard stirrup hooks as shown. Rotate or adjust reinforcing hooks to avoid interferences as required.
8. The thrie beam connection/post of Type 3G or 3H shall be adjusted or rotated to match the transition plate.
9. Posts, concrete curbs, and stirrups shall be perpendicular to the longitudinal roadway grade and cross slopes.

DESIGN DATA

Structural Steel:
 AASHTO M270 Gr 36 (ASTM A709 Gr 36) f_y = 36 ksi
 AASHTO M270 Gr 50 (ASTM A992/A572 Gr 50) f_y = 50 ksi
 ASTM A1085 f_y = 50 ksi

Concrete: Class D with Macrofiber f'_c = 4.5 ksi

Reinforcing Steel: f_y = 60 ksi min

All reinforcing bends shown shall use a 4D pin diameter.

INFORMATION ONLY

DESCRIPTION	UNIT	QUANTITY
Structural Steel (Galvanized)	LB	610
Concrete Sealer	SY	2.5
Concrete Class D with Macrofiber	CY	.7
Reinforcing Steel (Epoxy Coated)	LB	99

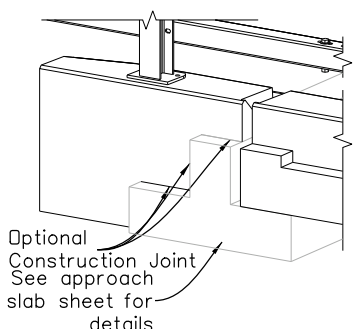
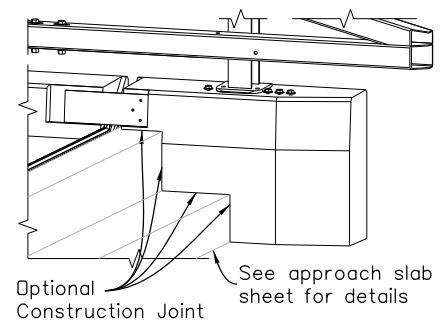
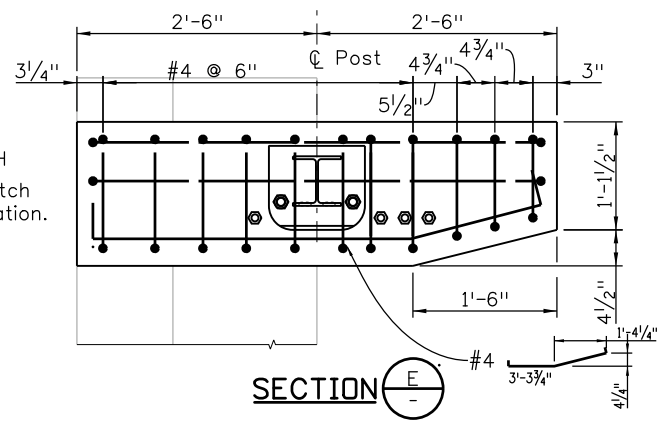
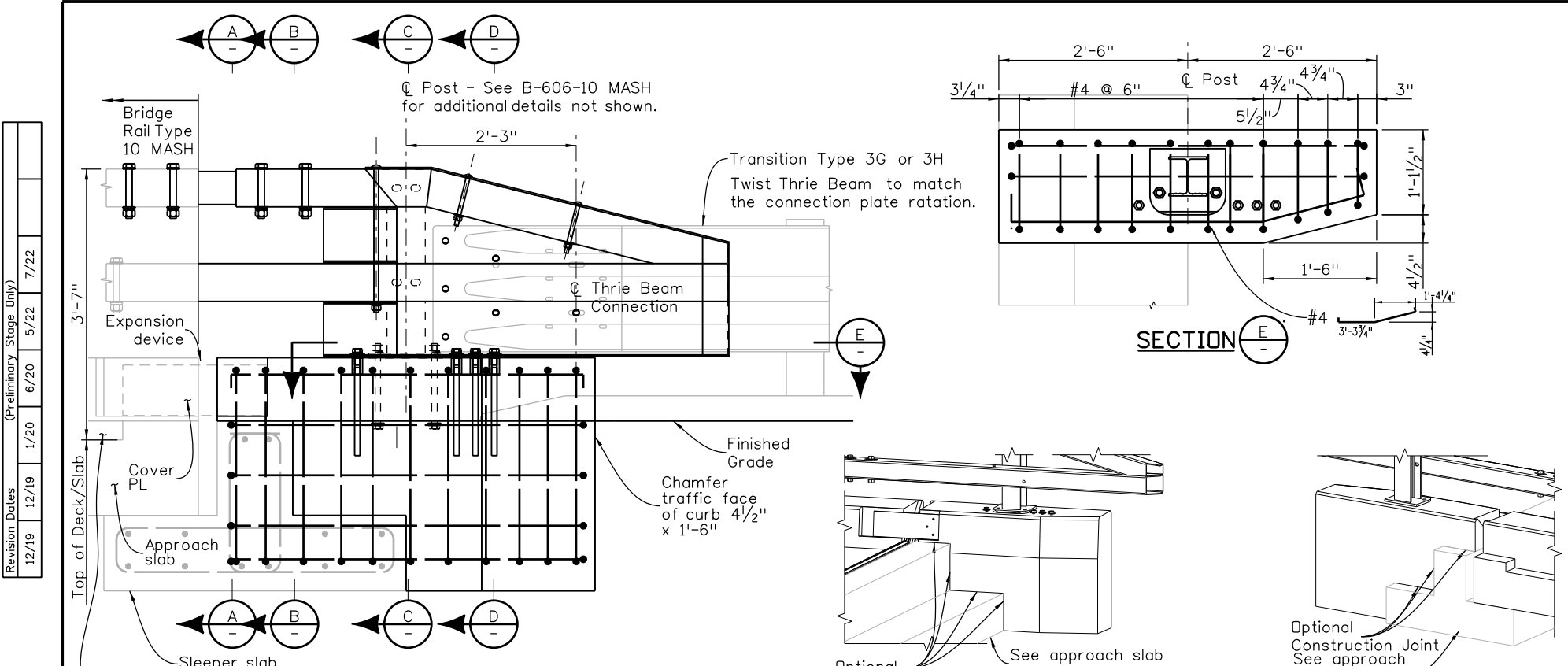

CONCRETE CURB DETAILS
 (Rebar shown at front face side only)

FRONT ISOMETRIC

BACK ISOMETRIC

Designer/Detailer:
 Any changes to the bridge rail transition details must be approved by Staff Bridge.

Note: Curb dimensions typical for all sections unless noted otherwise.

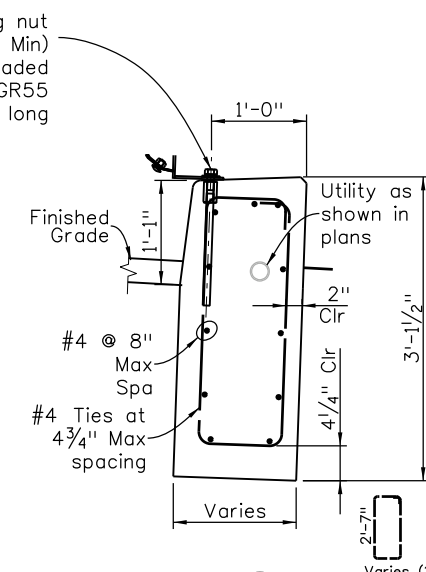
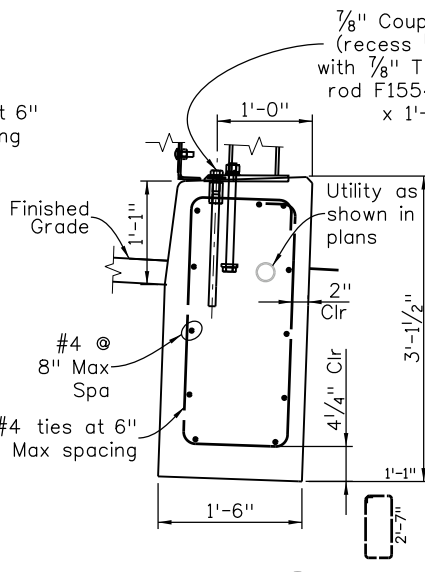
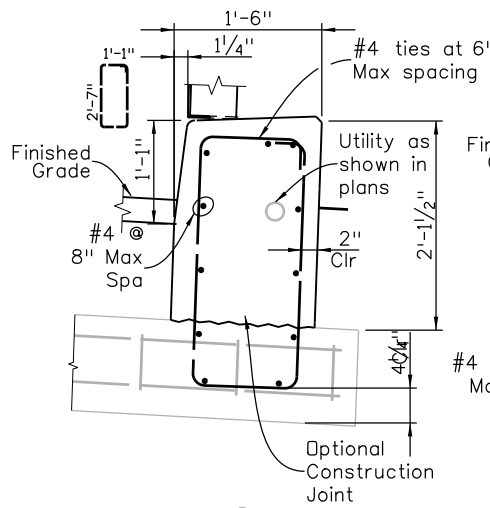
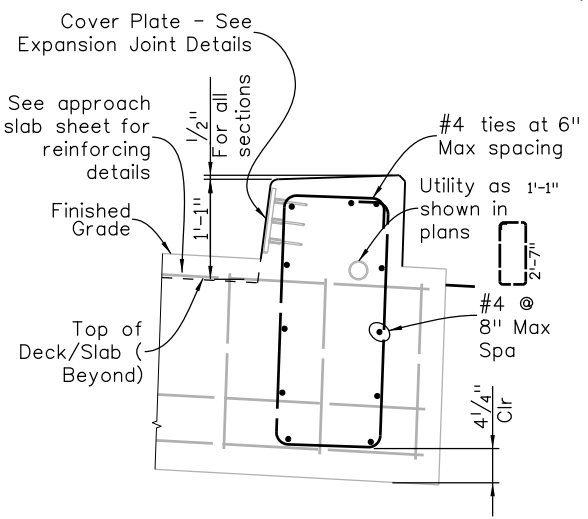

SECTION A

SECTION B

SECTION C

SECTION D

Note: Shaded linework is from other Pay Items

Revision Dates (Preliminary Stage Only)

12/19	1/20	6/20	5/22	7/22
-------	------	------	------	------

INITIALS	DESIGN	DATE	DETAIL	DATE	QUANTITY	DATE
By						
Checked By						

All seals for this set of drawings are applied to the cover page(s)

Print Date: \$DATE\$
File Name: Sheet_B-606-10MASHA.dgn
Horiz. Scale: 1:1 Vert. Scale: As Noted
Unit Information Unit Leader Initials

Sheet Revisions		
Date:	Comments	Init.

Colorado Department of Transportation

2829 West Howard Place, 3rd Floor
 Denver, CO 80204
 Phone: 303-512-5989
 Phone: FAX: 303-757-9197

Staff Bridge Branch

As Constructed
No Revisions:
Revised:
Void:

TRANSITION TYPE BR10M-GR3 SHEET 1 CURB DETAILS			
Designer: XXXXXXXX	Structure Numbers	X-XX-XX	Sheet Number
Detailer: XXXXXXXX	Subset Sheets: BXX of XXX	X-XX-XX	

Project No./Code
Project Number
Code
Sheet Number

\$PLOT_INFO\$