

SECTION 2 GENERAL DESIGN AND LOCATION FEATURES

2.1 GENERAL

This section addresses structure configuration, clearance requirements, aesthetic guidelines, structure investigation, and selection report requirements.

2.2 LOCATION FEATURES

2.2.1 Alignment

Care shall be taken during the preliminary design phase to ensure that horizontal and vertical alignments of the proposed bridge satisfy project objectives and minimum requirements of this BDM. Careful consideration of all feasible alternatives will minimize revisions at later stages. Structure layout alternatives shall be evaluated based on economic, engineering, environmental, construction, aesthetics, ease of inspection, cost of maintenance, traffic safety, bridge security, and utility avoidance factors.

2.2.1.1 Horizontal Alignment

Abutments and piers on curved bridges shall be placed to optimize the span lengths and girder spacings. Use of 1° increments is preferred when setting bridge skew, especially when not restricted by the existing construction. When a bridge is on a curve with a large radius, it is appropriate to consider a slightly wider straight bridge to lower the cost of construction. The Designer shall perform overhang design for the worst case cantilever.

When appropriate, preliminary design shall consider the possibility of future bridge widening.

Where practical, ends of approach slabs on bridges with skew $\geq 30^\circ$ should be set square to the roadway to facilitate construction and to minimize direct impact on the joint by snowplows.

2.2.1.2 Vertical Alignment

The Designer shall consider all local constraints and code requirements to ensure safety and to minimize interference with traffic under the bridge. Ultimate roadway configuration should be considered when setting bridge vertical alignment to accommodate any future bridge widenings.

2.2.1.3 Screed Elevations

The plans shall provide elevations of the bridge deck, approach slabs, and roadway approaches. Roadway approach and approach slab information is intended to avoid misalignments between the roadway and bridge. At a minimum, deck elevations should be provided at 1/10 points along control line, girder lines, crown line/centerline of the bridge, flow line, and edges of deck. At a minimum, approach slab elevations should be provided at 1/2 points along the approach slab crown and flow lines.

Bridge geometry shall be presented in the plans in accordance with Chapter 14 of the CDOT Bridge Detail Manual and CDOT Structural Worksheets.

2.2.2 Vertical Clearances

Required minimum vertical clearances to bridges passing over the rural and urban principal arterial routes shall be 16.50 ft. The minimum vertical clearance from the roadway to pedestrian bridges, utility bridges, and overhead sign supports shall be 17.50 ft.

**AASHTO
2.3.3.2**

Vertical clearance over low speed, low volume undercrossings (i.e., collector roads, streets, and private entrance crossings) may be modified to 15.00 ft. minimum with approval from State Bridge Engineer and concurrence of the owner of the low speed, low volume or private undercrossing. Any structures with clearance less than 16.50 ft. shall be signed as part of the project.

These values include 6 in. clearance for future overlays, structure deflections, snow on the road, vehicles oriented other than plumb, effects of sag vertical curves, future expansion, etc., which can be modified at the Owner's request. Provided values should be true over the entire roadway width, including shoulders. If construction requirements restrict the vertical or horizontal clearances to values lower than required at final design, Staff Bridge shall notify the Permit Department.

For vertical clearance from a pedestrian or bicycle path to an overhead obstruction, refer to Section 31.4.2 of this BDM.

Vertical clearance over waterways should be established based on hydrology and hydraulics explorations and shall also consider applicable watercraft clearance requirements. The Designer is required to provide adequate freeboard based on hydraulics elevations provided by the Hydraulics Engineer. At a minimum, freeboard for 100-year flood should be 2 ft for low to moderate debris streams with velocities > 6 fps. See Chapter 10 of the CDOT Drainage Manual for additional clearance information. When minimum freeboard clearances are not feasible, a hydraulic variance will be required. If freeboard requirements are not met, bridge and bridge connections shall be designed for any additional lateral loading due to the lack of clearance.

2.2.3 Horizontal Clearances

Horizontal clearances shall conform to AASHTO and *A Policy on Geometric Design of Highways and Streets*.

**AASHTO
2.3.3.3**

Figure 2-1 to 2-3 summarize the minimum requirements for horizontal clearances. These are preferred configurations and should be evaluated and modified as appropriate. Modifications may be appropriate based on the location of the existing drainage features and the cost benefits of balancing or adjusting span lengths.

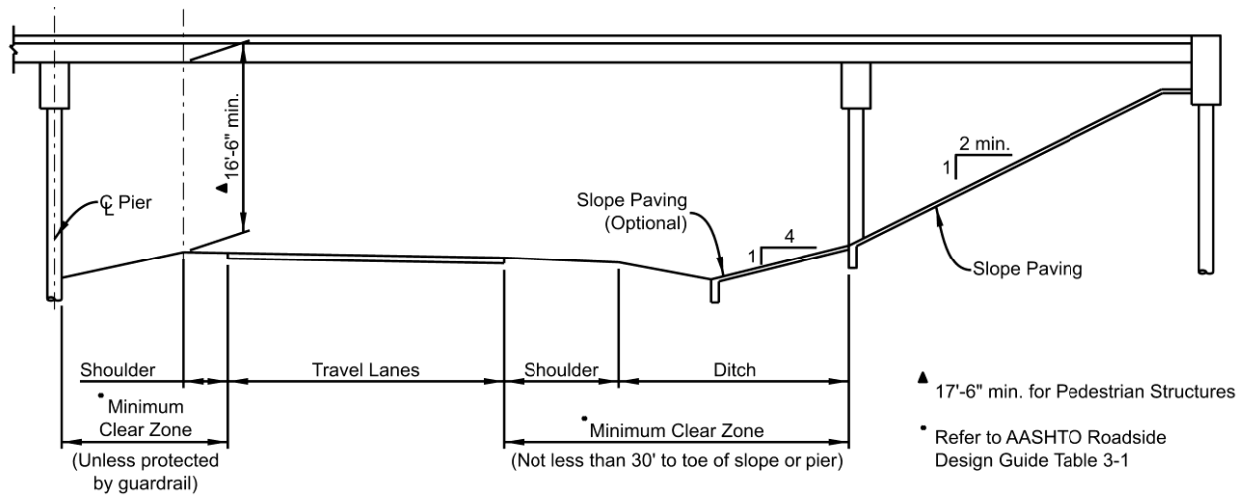

Figure 2-1: Bridge Clearances – High Speed Roadway
 Design speed > 45 MPH

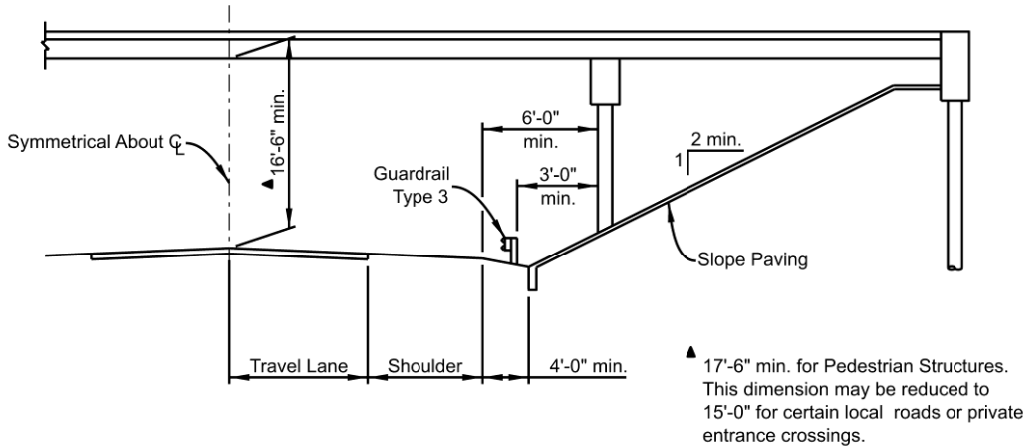

Figure 2-2: Bridge Clearances – Low Speed Roadway
 Design Speed ≤ 45 MPH

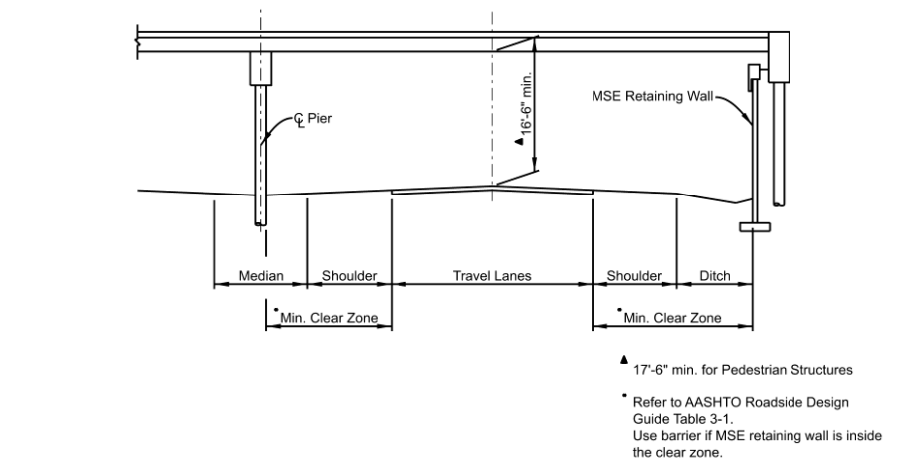

Figure 2-3: Bridge Clearances with MSE Retaining Wall

All undercrossings and roadways

2.2.4 Criteria for Deflection

Design shall follow deflection criteria outlined in AASHTO 2.5.2.6.2. When these criteria cannot be met, a variance request shall be submitted to the Unit Leader.

**AASHTO
2.5.2.6.2**

2.2.5 Sidewalks

For an attached sidewalk on a vehicle bridge, the clear walkway shall be 5 ft. minimum but in no case shall it be narrower than the approaching sidewalk. Additional width may be required in an urban area or for a shared pedestrian-bikeway facility. Curb height of the raised sidewalk on the bridge should not be less than 6 in. above the final grade. If the deck does not have an asphalt layer, the sidewalk height should be increased to 9 in. to account for future overlays. Raised sidewalk shall be connected to the deck using fully developed reinforcement.

**AASHTO
13.11.2**

When requested by Owner or when pedestrian walkways are provided on high speed, high volume bridges, walkways shall be protected with a combination of inboard traffic barrier (Bridge Rail Type 9 or Type 10 MASH) and outboard pedestrian railing. Any other rail shall be approved by the State Bridge Engineer in coordination with the Bridge Rail SMEs. High speed roadways are defined as those with a speed limit greater than 45 mph. Refer to Figure 2-4 for sidewalk details. When pedestrian traffic is high, a separate pedestrian bridge shall be considered based on a combination of factors such as cost, safety, phasing and site conditions. Roadway / trail designers shall assist in performing applicable studies as required. For high speed, high volume roadways, the Project Engineer decides whether or not to separate traffic and pedestrian facilities. See Section 2.4.2 for fencing information.

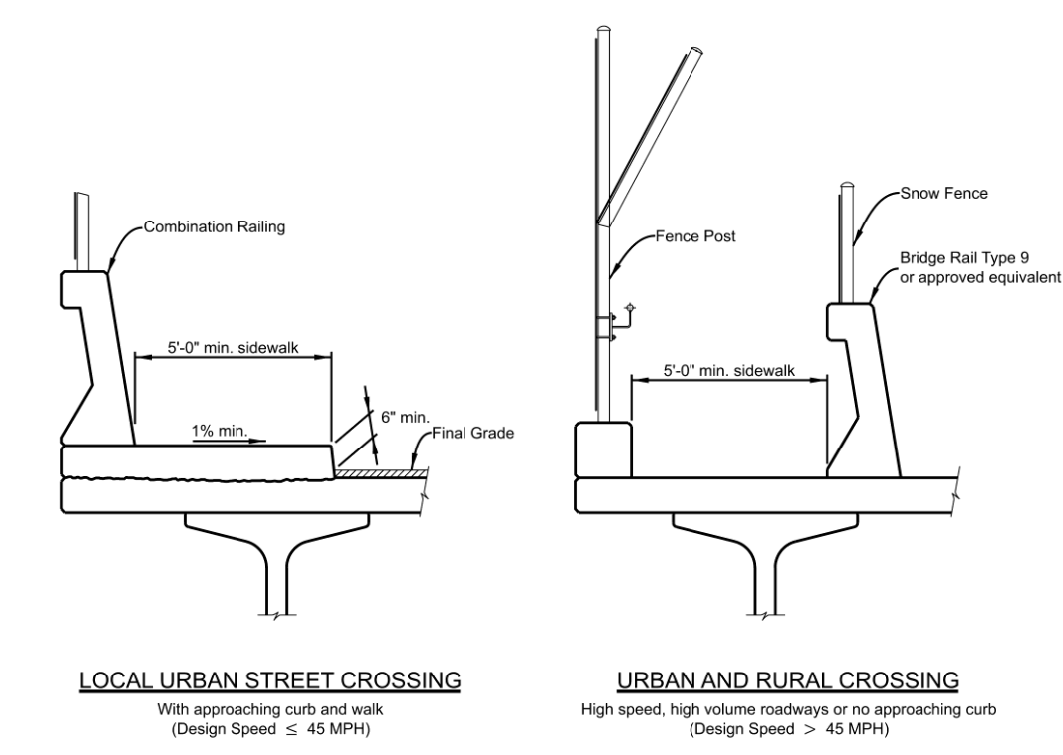
**Figure 2-4: Standard Sidewalk Details**

2.2.6 Environmental Considerations

Minimizing and mitigating environmental impacts of any construction project shall be given the highest priority. All proposed projects shall be evaluated for all possible environmental impacts at the preliminary stages of the design. Engineers and Contractors shall comply with state and federal laws concerning all environmental issues, including, but not limited to:

AASHTO 2.3.4

- Ecological impacts on wetlands
- Water pollution and contaminated materials
- Erosion and sediment control
- Streams and floodplains encroachment
- Removal of embankment stabilizing vegetation
- Fish/wildlife habitation or migration routes
- Unstable slopes
- Noise/vibration control policy
- Hazardous materials and solid waste
- Asbestos containing materials/soils
- Transportation and discharge of hazardous materials
- Spill reporting
- Impact on local communities
- Historic/archaeological/paleontological sites

2.3 AESTHETICS

2.3.1 General Requirements

Aesthetic enhancements are defined as items not necessary for the load carrying capability of a bridge or a structure, such as facades, monuments, and artwork. The level of aesthetic treatment will vary from project to project depending on the importance of the structure, sensitivity of the setting, construction budget, location, historical value, and Owner's preferences.

AASHTO 2.5.5

CDOT has a Visual Resources Program (VRP), administered by the CDOT Environmental Programs Branch, Landscape Architecture Section. The CDOT Landscape Architect's primary goal regarding aesthetics is to objectively measure, following standard methodology, the visual impacts for projects supporting the transportation system to meet legal requirements and regulations, while maintaining and improving scenic quality. The primary value of the Landscape Architect in structure design is to create beautiful and pleasing structures in harmony with the surroundings. Early in the project's development process, the Engineer shall coordinate with the Landscape Architect for project aesthetics requirements. The Landscape Architect will review and provide aesthetic recommendations for any bridge/structures based on the VRP principles of integrating, designing, and recommending visual solutions for bridges and other structures. "A beautiful design can only be achieved if the aesthetics design is developed as an essential part of the total concept" (Transportation Research Board and National Research Council, 1991, p. 8, Bridge Aesthetics Around the World, Washington DC).

Bridge and structures will be reviewed from several vantage points. The CDOT Landscape Architect shall determine the users and neighbors/community and consider views of the road, both from and of the road, to generate a sense of place, security, and context of scale by incorporating Context Sensitive Solutions (CSS). Context sensitive design acknowledges a concern for local architectural identity and investment.

The approach to CSS aesthetics is an iterative process with many aspects of aesthetic design review, to build on a framework for color, scale, style, direction, proportion, shape, form, balance, etc. Corridor themes are established by developing a complementary appearance between varying bridge/structure types and components along the corridor. Every structure will receive architectural and aesthetic design reviews and recommendations during the design and construction phase.

If the bridge is a part of a specific corridor, it must be visually consistent with the overall scheme of the corridor. Cost-effective aesthetic treatment can be achieved by using color coating, staining, colored concrete, form liners, rustications, and other methods. CDOT practice limits aesthetic treatment costs to less than 5 percent on any individual project and 2 percent at the statewide program level, unless outside funding is provided. Veneers are generally discouraged based on safety, durability, and maintenance concerns.

Aesthetic enhancements shall not be attached to the main load carrying members of the structure, that is, girders, pier caps, columns, etc., without approval from CDOT Unit Leader. Any attachment of aesthetic enhancements to the structure shall be detailed and/or designed to prevent deterioration (e.g., corrosion) that may damage or degrade any component of the structure. Aesthetic enhancements shall not be placed in locations or consist of components that in any way limit access to or inhibit the inspection of the structure. Any permanent aesthetic enhancements within CDOT ROW shall not impact the safety of the traveling public.

The requesting entity shall maintain and repair the aesthetic enhancements. An IGA is needed to determine appropriate responsibility to maintain which bridge/structures/components and should be archived by the Engineer for future reference. Access to CDOT ROW to maintain or repair the aesthetic enhancements in the future would be requested and approved through the CDOT Access Management Permit Office.

2.3.2 Lighting

The placement and type of lighting poles and fixtures can have a major visual impact on the overall appearance of the bridge. Poles should be set such that they are visually complementary to the structure.

Superstructure-mounted highway lighting shall be avoided wherever possible. The Designer shall investigate the possibility of mounting the lighting on an extended pier cap. If superstructure-mounted lighting cannot be avoided, it shall be located as closely to a pier as is practical to limit movement and vibration.

Underdeck lighting should be provided on bridges over roadways and trails when requested by the region. It is preferable to place the underdeck lighting on

substructure elements rather than directly on the deck to allow easier deck repairs and replacement.

When lighting for pedestrian bridges is provided on poles, it should be independent of the bridge structure where possible. Other lighting options can be evaluated on a case-by-case basis. Pedestrian lighting should be incorporated into local underpasses. Structural plans should be coordinated with electrical plans for conduit splices and locations, expansion/deflection coupler locations considering longitudinal and lateral deflections, fixture locations, and mounts to avoid conflicts during construction. Any bridge lighting configuration must be readily accessible for inspection and maintenance. All junction boxes maintained by Xcel Energy must comply with Xcel Energy requirements. Xcel Energy junction box size is typically 18 in. x 8 in. x 6 in.

2.3.3 Form Liners and Veneers

Both form liners and veneers can be used to create desired architectural surface treatments, such as intricate patterns, stamps, murals, etc., to increase the aesthetics of the bridge or retaining wall. The use of integral aesthetics, such as form liners, rather than rock veneers, is preferred to limit possible delamination and flying debris from impact. The CDOT Unit Leader shall approve any attachment of architectural enhancements to the load carrying members. All such attachments shall be adequately designed and detailed on the plans.

For vertical and nearly vertical concrete surfaces with rustICATIONS that are accessible to pedestrians, practical means should be considered to make these surfaces unattractive for climbing. To reduce the construction labor required to make these rustICATIONS, they should be made in dimensions that use standard lumber sizes with a minimum number of cuts. In all cases, grooves should have at least one beveled edge to facilitate removal of the lumber strips used to form them. Figure 2-5 shows examples of unacceptable configurations and suggested details. This does not apply to standard prefabricated form liners with vertical flute configurations that have proven to be practical from previous use.

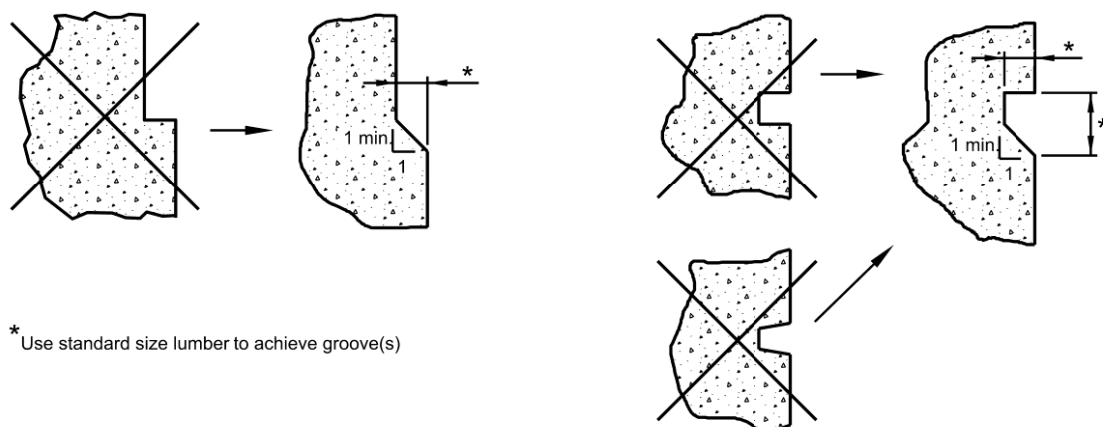

Figure 2-5: Vertical Concrete Surface Details

2.4 RAILING AND FENCING

The overall height and shape of the safety barrier and fence should meet or exceed AASHTO standards. Railings and fencing installed on retaining walls should be consistent with or complementary to those found on adjacent bridges.

AASHTO 13.4

To improve durability, the use of weathering steel for railing and fencing is discouraged. Galvanizing of steel portions of safety barriers and fences is the minimum standard required. In cases where steel portions of safety barriers and fences are to be painted for aesthetic or other reasons, it must be done in addition to galvanizing using a duplex coating system.

Chain link fence is not required to be painted, but for aesthetic purposes a vinyl coating can be added.

It is recommended that dissimilar metals be avoided to improve durability. The use of aluminum or galvanizing steel are acceptable but combinations should be avoided.

2.4.1 Railing

2.4.1.1 Traffic Railing

MASH compliant and crashworthy railing systems shall be used adjacent to vehicle traffic. Bridge rail Type 9 and Type 10 MASH are CDOT's MASH compliant bridge rails and shall be used for all new construction. New construction consists of new bridges and bridges being rehabilitated or widened in a manner that requires removal of the existing bridge railing. Refer to CDOT Staff Bridge Worksheets for details of bridge traffic railings. Any changes made to bridge rail and/or the transition worksheets will require a variance from the State Bridge Engineer in coordination with the Bridge Rail SMEs. Any modified or non-CDOT bridge rails proposed for projects should be crash tested or suitably evaluated to ensure MASH compliance and crashworthiness.

AASHTO 13.7

All existing bridge rails that meet the current AASHTO *and* MASH criteria may remain in place. If the bridge falls within the limits of a Federal-Aid project, if sufficient funds exist, or if it is an essential repair, rails should be modified to meet these standards or be replaced with a MASH compliant rail or rehabilitated to meet MASH compliance.

The Type 9 and Type 10 MASH bridge rails, shown on Figure 2-6, are typically used for nearly all new construction on state highway projects. These rails offer the overall optimum solutions given safety, cost, maintenance, appearance, and guardrail compatibility issues. For local agency projects a test level lower than TL-4 may be approved by State Bridge Engineer in coordination with the Bridge Rail SMEs based on design speed, ADT and other safety factors. Bridge rails and transitions at any test level shall be MASH compliant and crashworthy.

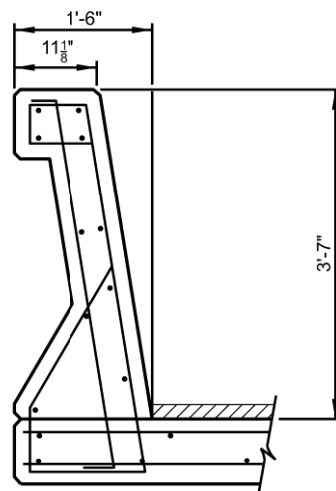
**BRIDGE RAIL TYPE 9**

(See B-606-9 for more details)

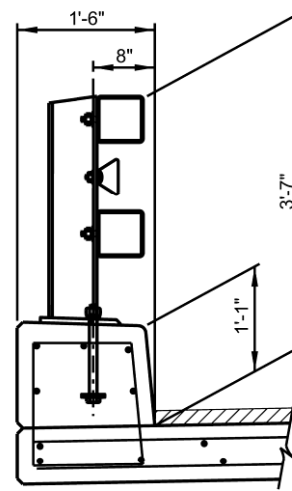
**BRIDGE RAIL TYPE 10 MASH**

(See B-606-10 MASH for more details)

Figure 2-6: Bridge Rail Types 9 and 10 MASH

2.4.1.2 Pedestrian Railing

The height of pedestrian railing should not be less than 42 in. Openings between horizontal or vertical members on pedestrian railings shall be small enough that a 4 in. sphere (IBC requirement) cannot pass through them. This value shall be used in lieu of AASHTO requirements and shall apply to the full height of the railing.

**AASHTO
13.8.1**

2.4.1.3 Bicycle Railing

Where specific protection of bicyclists is deemed necessary the minimum height of railing used to protect a bicyclist shall be 42 in., measured from the top of the riding surface. Bicycle railing with horizontal members is preferred when allowed. Chain link fence may be used in lieu of bicycle railing. Smooth rub rail shall be attached to the barrier or fence at a handlebar height of 42 in., unless a smooth surface is already provided. See AASHTO Bicycle Facilities Guide and CDOT Roadway Design Guide for more information.

**AASHTO
13.9.1**

2.4.1.4 Combination Railing

Combination railing is a type of traffic railing that also satisfies the height and opening requirements of either the pedestrian or the bicycle railings. Where combination railing (pedestrian/bicycle and traffic) is provided, the combination rail modified from CDOT MASH compliant rails shall not interfere with the crashworthiness of the MASH compliant rails or cause other hazards (such as spearing) to the traveling public.

**AASHTO
13.10.1**

2.4.1.5 Safety Railing

Safety railing is intended to provide limited fall protection and visual identification of the vertical drops. The top of safety railing should be at least 42 in. above

walking/working surface. Intermediate members (such as balusters), when used between posts, shall not be more than 19 in. apart.

2.4.1.6 Handrail

Handrail is intended to meet ADA requirements (See Section 31.7) and may be required in addition to Pedestrian and Bicycle Railing. When required, handrail shall be placed at a height between 34 and 38 inches above finished grade. Handrail may be similar to bicycle railing details.

2.4.2 Fencing

2.4.2.1 Chain Link Fence

All bridges with pedestrian or bicyclist access that cross roadways or railway tracks shall be provided with chain link fabric fence or other approved fencing to prevent objects from being thrown onto the road below. Fencing other than those noted below shall be approved by the CDOT Unit Leader. The addition of fencing to the bridge rail may affect its crashworthiness and test level criteria.

The maximum size opening for chain link fabric shall be 2 in. Other approved fencing includes the use of picket fences with a maximum clear opening of 4 in. between pickets. Fencing should extend, as a minimum, 30 ft. beyond the outside shoulder line on the traveled way below, the bridge rail length, or as required per railroad criteria. Bridges with pedestrian walkways over traffic should have pedestrian fencing on the barrier or the curb.

Partial enclosure pedestrian fence should be considered at locations where there is a history of objects being thrown over the fence. The Designer should coordinate with the Region to determine these locations. The minimum overall height of the barrier and fence above roadway surface should be 8 ft. Fence above railway tracks shall be 10 ft. for vertical fence and 8 ft. for partial enclosure fence. Refer to Figure 2-7 for more details.

Horizontal pipe members should be avoided as they are a spearing hazard.

2.4.2.2 Snow Fence

A snow fence prevents snow from splashing over the barrier during snow removal. Snow fencing shall be required over highways, over railroad facilities, and on other bridges per Region requests.

Snow fencing may be used over pedestrian paths per Region requests. The minimum height of the snow protection should be 36 in. with 3/8 in. mesh and should extend, as a minimum, 30 ft. beyond the outside shoulder line on the traveled way below, the bridge rail length, or as required per railroad criteria. Designer shall verify the limits of snow fencing with Traffic Safety for any obstructions to sight distance.

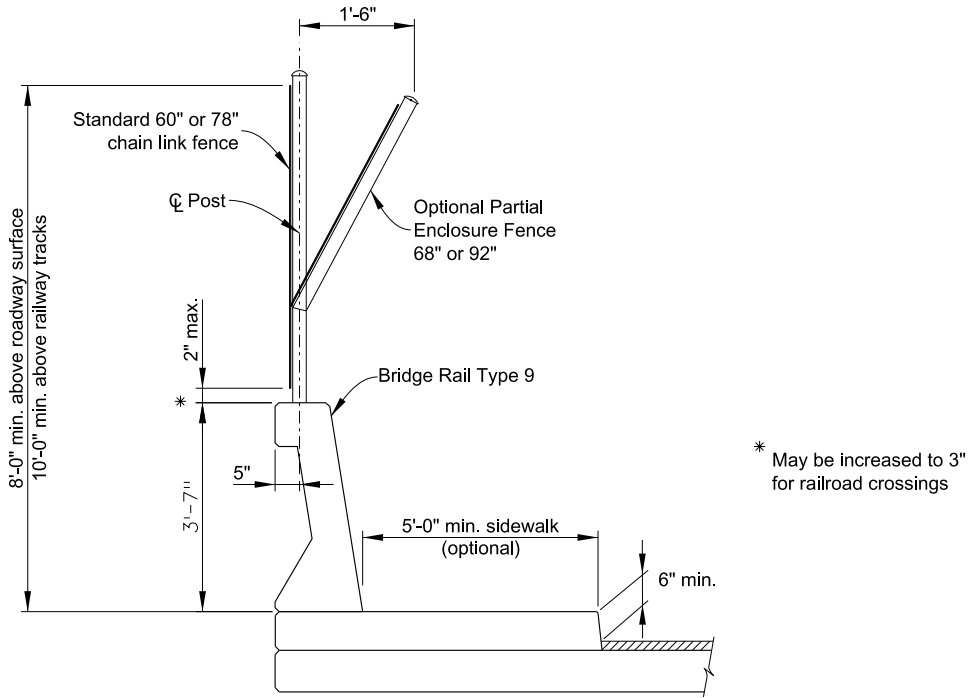

FENCE, SPEED ≤ 45 MPH

With optional approach curb and walk
 See B-607-5, B-607-6B, B-607-778, and B-607-8B for additional details

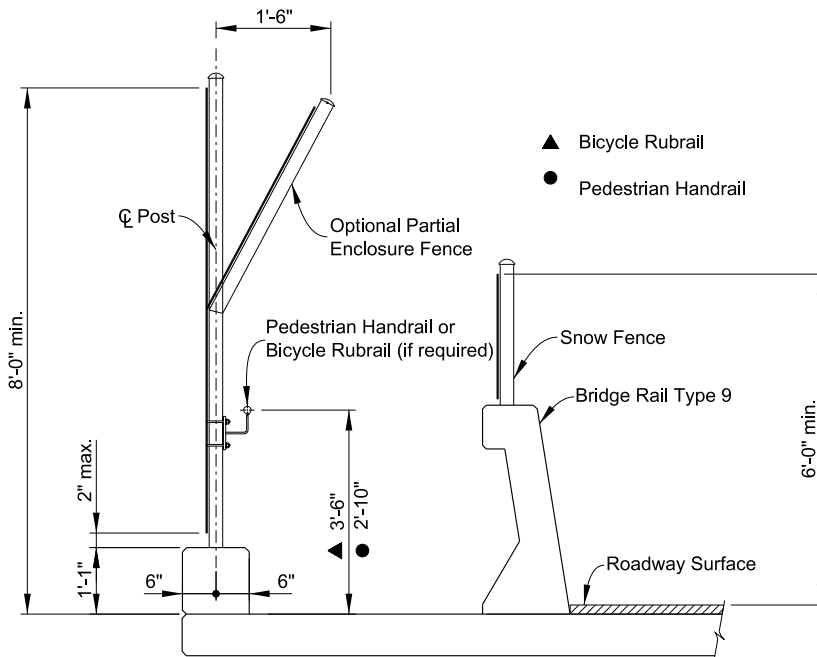

FENCE, SPEED > 45 MPH

High speed, high volume roadways or no approach curb
 See B-607-3 for additional details

Figure 2-7: Fencing Types

2.4.2.3 Drop-Off Protection

Drop-off protection is categorized as follows:

- Pedestrian Protection** – Pedestrian railing shall be provided for any sidewalk or shared use path adjacent to a wall with a drop-off greater than 30 in. Safety railing or fencing shall be provided for walls with drop-offs greater than 30 in. that are generally accessible by the public but not adjacent to sidewalks or paths.
- Shared Path Users Protection** - It is preferred that a 5 ft separation be provided between a shared use path and drop-offs or embankments with slopes greater than 4:1. Otherwise a suitable barrier such as a railing or fence shall be provided at the top to the slope. Refer to Chapter 14 of the CDOT Roadway Design Guide for more details on shared use path next to embankment slopes protection requirements. Safety railing or fencing shall also be provided for walls with drop-offs greater than 30 in. that are not adjacent to sidewalks or paths but are generally accessible by the public."
- CDOT Maintenance Personal Protection** – Fall protection, including safety railing, fencing (chain link or 3 cable), or tie-off points, as approved by CDOT Maintenance, shall be provided at all wall drop-offs greater than or equal to 4 ft. in areas restricted to public access by either location or fencing.

Safety railing and fencing in all cases shall be capable of resisting 200 lbs. of force, applied to the top of the longitudinal element acting in any direction.

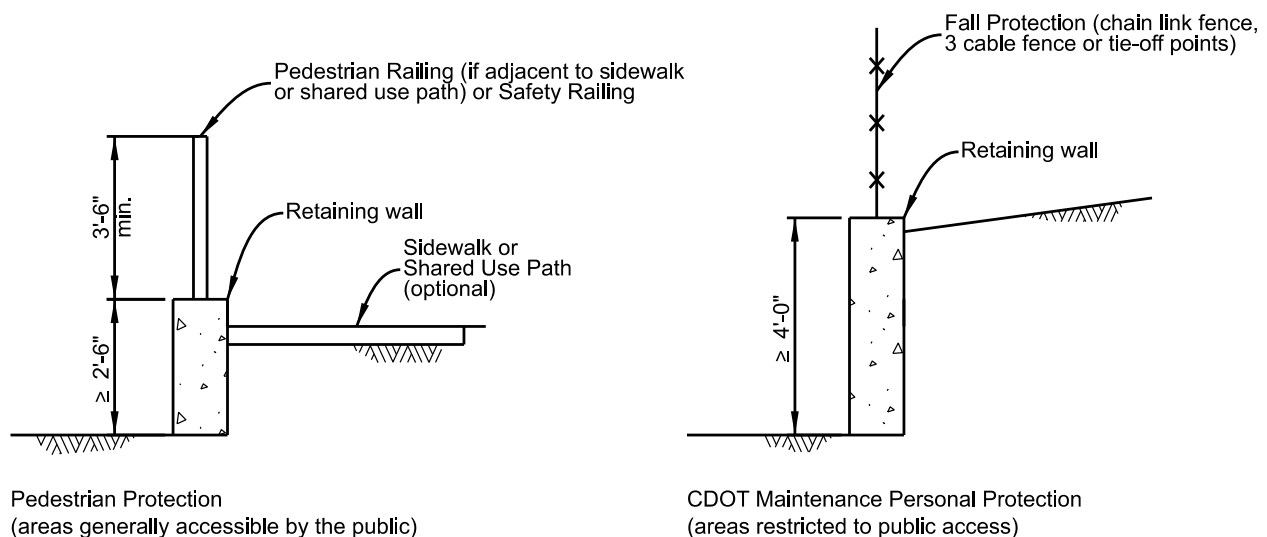

Figure 2-8: Drop-Off Protection

2.5 RAILROAD REQUIREMENTS

2.5.1 General Requirements

New bridges designed to overpass a railroad should be designed per AASHTO specifications, except for clearance requirements, which shall conform to the

American Railway Engineering and Maintenance of Way Association (AREMA). When designing a bridge carrying a railroad, using the railroad's preferred design and materials may accelerate the review process but a Structure Selection Report is still required. Some local railroad agencies, such as BNSF and UPRR, have set requirements that are more conservative than those outlined in AREMA. These requirements should be met, if required. However, if adherence to the local railroad's requirements results in an impractical or a non-cost-effective design, the Owner should be notified and the decision should be made on a case-by-case basis. Railroads typically specify intermediate reviews of the design e.g. 30%, 60% and 100% etc. depending on the contract requirements. These submittals may require extensive interruption in the design process while the railroad reviews the design for compliance. It is important for a checker to be assigned to the project early so any design discrepancies can be dealt with prior to each submittal.

2.5.2 Vertical Clearance

All highway bridges over non-electrified railroads are required to have a minimum vertical clearance of 23 ft above the top of rail per AREMA guidelines. Note that greater clearances are required for tracks on a curve. For details, refer to *AREMA Manual for Railway Engineering*, Chapter 28. Typically, local railroad request clearance greater than 23' (23'-4" for UPRR, 23'-6" for BNSF). The Structure Selection Report should evaluate and discuss the difference in cost if a vertical clearance larger than the normal practice specified in the design guidelines is requested. If the cost is minimal, the project will fund the difference. If the cost is excessive, the local railroad should be required to fund the additional cost. Please refer to FHWA memo 130416 for discussion of funding eligibility for additional information. The railroad shall document or justify by special site conditions the need for clearances greater than those shown or referenced herein.

2.5.3 Horizontal Clearance

It is preferable to keep bridge piers outside the railroad ROW or the 25 ft clear zone, measured perpendicular to the centerline of the track. Piers located less than 25 ft from the centerline of the outside track shall meet the requirements to qualify as heavy construction or are to be protected by a reinforced concrete crash wall. Absolute minimum horizontal clearance to the face of the pier protection wall should meet *AREMA Manual for Railway Engineering* or local railroad's requirements.

2.5.4 Construction Clearance

Minimum vertical temporary construction clearances shall be 21'-6" (22'-6" AREMA) above the top of the high rail. Greater temporary clearances may be required on a project-by-project basis. Minimum horizontal construction clearances measured perpendicular to centerline of track to nearest obstruction (formwork, equipment, stockpile materials, etc.) should satisfy requirements set by the local railroad. Any excavation work within these limits requires approval of the railroad.

2.5.5 Protection and Screening

All highway bridges over any railroad shall include a fence with a barrier, approved by the railroad, on both sides of the structure, extending to the limits of the railroad ROW.

If the structure over the railroad tracks is subject to snow removal, one of the following must be provided: barrier rail with height not less than 42 in. or a snow fence or splashboard extending to the limits of the railroad ROW. Splashboards shall be included in the cost of Fence Chain Link (Special).

Some local electrified lines require arc flash shielding at the bottom of concrete girders. Coordinate with the Owner's design standards for protective shielding details and grounding requirements.

2.5.6 Collision

Refer to the AREMA *Manual for Railway Engineering* or local railroad guidelines for heavy construction piers and crash wall requirements. Criteria regarding vehicle and railway collision loads on structures found in AASHTO are also applicable to the design of crash walls, as appropriate.

2.6 INSPECTION ACCESS

All bridge girders, bearings, external tendons, and fracture critical details shall be made accessible for long-term inspection from the ground, from walkways installed within the girder bays, or by means of a Below Bridge Access Vehicle (BBAV). Areas that are to undergo inspections shall be provided with handles and ladder stops as applicable. Bridges requiring BBAV access shall have a minimum clear distance of 12 ft. between the outside edge of barrier and any obstruction (building, parallel structure, etc.) for access. Bridges accommodated by regular inspection vehicles need 6 ft. minimum, up to 10 ft. preferred of lateral shoulder clearance.

All steel box girders, cast-in-place concrete box girders and precast concrete tub girders with an inside depth of 5 ft. or more shall be made accessible for interior inspection. Bottom flange or slab access doors shall swing into the girder and, when possible, shall be placed at locations that do not impact traffic under the bridge. Lock protectors, doorstops, and tie off hooks inside the girders shall be provided. Steel box girders, cast-in-place concrete box girders and precast concrete tub girders without access shall have 4 in. (minimum) diameter weep holes for camera access at 10 ft. maximum spacing.

Access doors into the girder shall be aluminum, providing a 2 ft. by 3 ft. minimum opening, and shall open to the inside of the box girders. The doors shall be locked by a single padlock protected by a lock guard. Neither bolts nor screws may be substituted for the padlock. An example access door for steel box girders is shown on Figure 2-9 and on Staff Bridge Worksheet B-618-2 for concrete box girders.

To prevent corrosion between the aluminum door and the adjacent steel, the plans should call for shop coating, as a minimum, of the aluminum to steel surfaces on painted girders. The Designer may call for rubber shims at the interfaces with unpainted ASTM A588 steel if desired.

For payment, the aluminum plate should be included in the work for the girder. It should not receive a separate pay item. The plans should call for ASTM B209 aluminum plate, alloy number 6061-T6. Additional material specifications are not needed.

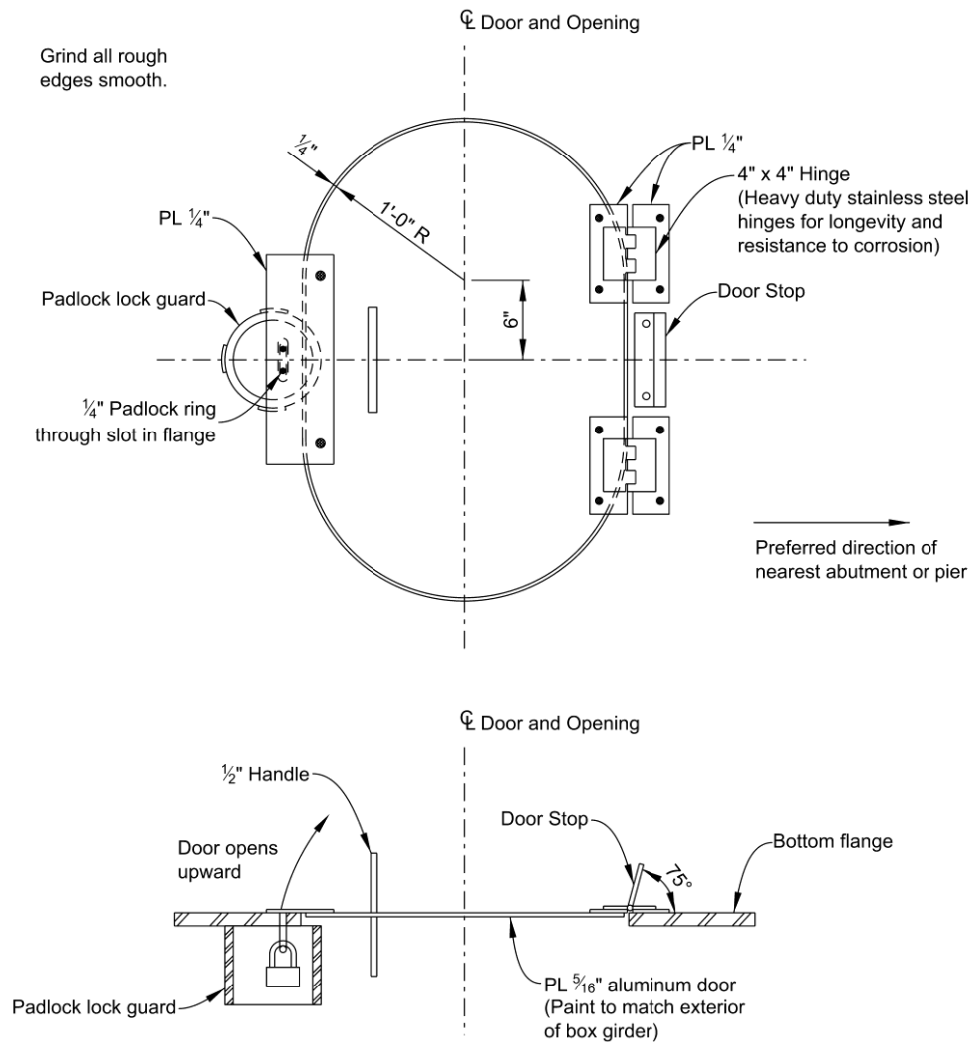

ACCESS DOOR DETAIL

Door shall be aluminum ASTM B209 alloy No. 6061-T6.
 Other hardware and plates are ASTM A36 steel.
 Door and associated hardware to be included in
 Item 509 Structural Steel.

Figure 2-9: Access Door Detail

Traffic, required ladder heights or BBAV reaches, and other obstacles shall be considered when locating access doors. Where possible, access doors near abutments should be placed 3 ft. minimum to 4 ft. maximum clear from top of ground to allow entry without a ladder. Where a ladder must be used above slope paving, support cleats or level areas for the ladder shall be provided in the slope paving.

Access through diaphragms within boxes shall be provided by openings with a minimum area of 5.70 ft² and a minimum width dimension of at least 24 in. The bottom of the opening through diaphragms within boxes shall not exceed 2.50 ft. from the bottom of the girder unless details for passing through higher openings are provided; for example, step platforms or climbing handles up the side of the diaphragm, and, if necessary, along the bottom of the deck. If possible, the bottom of diaphragm access should be flat for ease of use.

Attachments to diaphragms, such as bearing stiffeners, and to other possible projections shall be detailed so that they will not present a hazard to someone passing through the box. Using k-type bracing shall provide an opening through steel box girder intermediate cross frames.

2.7 FORMWORK

All internal formwork, waste, and debris shall be removed from precast and cast in place girders that are made accessible for internal inspection by means of an access door or a camera. For shallow cast-in-place box girders with no access door, pour should occur in two stages to allow formwork removal (unless approved by CDOT Unit Leader.)

A note shall be placed on the plans to phase the construction and remove internal formwork for both cast in place and precast girders that require internal inspection.

2.8 UTILITIES

A request for permission to attach utilities to existing bridge structures should be coordinated through the District Utility Engineer, who should submit the request, in writing, to Staff Bridge. Such requests shall state the following:

**AASHTO
2.5.2.5**

- Proposed schedule for installation
- Location of the conduits
- Type of conduit sleeve required
- Size, spacing, capacity, and number of inserts

When attending the FIR meeting, the Designer should inquire as to what utilities and conduits for future use the bridge will carry to assure that they are accommodated. The Utility Group/coordinator should provide information on the size and number of conduits needed for proposed utilities as well as required future or spare utility conduits. The bridge plans shall indicate the size, spacing, and capacity of the utilities and the basis of payment for installation. The Designer shall verify and show the locations of pull boxes and j-boxes to allow future use. Pull boxes or other method shall be provided for all utility lines. See BDM Section 2.3.2 for the typical size of Xcel pull boxes. Unless utilities provide more defined guidance, pull boxes shall be provided every 150 ft. in length or 360 degrees of turns of the conduit. Buried conduit is to have 500 ft. of length between pull boxes. Each utility may have further guidance. The Designer shall coordinate with the lighting and utility discipline for additional requirements.

Utilities should be installed either inside the concrete barrier or underneath the bridge deck with the blockouts provided through abutments and pier diaphragms. CDOT prefers to install small utility conduits inside the barrier whenever practical.

For aesthetic and safety reasons, conduits on new bridges will not be permitted to be installed under deck overhangs or on bridge railings.

Installation of utilities on bridges in service shall be coordinated with CDOT Unit Leader. Typically, spare conduits are used when utilities are added while a bridge is in service. If spare conduits are not available, the Vendor will need to provide anchoring details for approval by CDOT Unit Leader. Details will need to be evaluated for any detriment to longevity or durability of the existing bridge.

Whenever utilities are installed externally, hanger or support spacing will depend on the size and material of piping supported, e.g., 2 in. PVC conduit may require 5 ft. ± spacing, while 2 in. steel conduit may require 10 ft. ± spacing. Spacing shall be designed to limit deflection to less than ½ in. The utility owner should specify spacing, and it shall be coordinated with Staff Bridge. Information about weight of piping and heaviest conductor can be found in the National Electrical Code.

Blockouts shall be sized to accommodate only those utilities to be installed during bridge construction. Blockouts for the installation of "future" utilities shall not be provided. Blockouts shall not extend below the bottom of the girders. It is preferable to avoid utilities with rigid pipes through integral abutment. When such installations cannot be avoided, the effects of the abutment backfill settling and the effects of superstructure translational and rotational movements need to be considered in the design and properly detailed.

Waterlines, gas lines, and other safety issue utilities shall not be located within tubs or boxes unless approved by CDOT Unit Leader. If a waterline is approved for use inside tubs or boxes, relief or drainage valves shall not be located within the girder and a full length casing for the utility is preferred.

ITS utility boxes need to be coordinated if a sound wall will inhibit access.

2.9 FOUNDATION INVESTIGATION

2.9.1 General

Geotechnical explorations shall meet requirements of AASHTO and the CDOT [Geotechnical Design Manual](#). The proposed subsurface investigation, including means and methods, should be disclosed and fully discussed with the Structural Engineer of Record prior to start of work.

2.9.2 Geotechnical Report Requirements

Minimum requirements for the Geotechnical Report deliverables for bridges, retaining walls, and box culverts, as well as the Geotechnical Report Checklist, designed to assist a reviewer, can be found in the CDOT Geotechnical Design Manual.

AASHTO 10.4

2.9.3 Code

All geotechnical design information shall be provided in LRFD format. Preliminary design may be provided in Allowable Stress Design (ASD) format but shall not be used for final design. Exceptions can be made for bridge widenings where the original design was done in LFD.

2.9.4 Global Stability

Stability requirements, particularly global stability of walls and tall wall abutments, shall satisfy the requirements of the Geotechnical Design Manual and AASHTO. The Geotechnical Engineer of Record shall perform the overall global stability calculations. Structural Engineer of Record is to verify that these calculations are completed.

Loss of support due to erosion of riprap layers, soil removed during design and extreme scour events, pavement structure replacement (wearing surface and base course layers), future utility excavations, etc., should be considered in design.

2.9.5 Deliverable

Final sealed Geotechnical Reports for all new structures shall be provided to CDOT Staff Bridge. Preliminary foundation recommendations should be provided when possible.

2.10 STRUCTURE SELECTION REPORT

2.10.1 General Requirements

The Structure Selection Report presents the results of the preliminary design process and represents good stewardship of available funding. To find feasible solutions, constraints such as serviceability requirements (deflection, settlement, etc.) and spatial limitations (ROW, underground easement, etc.) should be defined as comprehensively as possible. All solutions shall be evaluated, compared or discussed regarding feasibility, advantages and disadvantages. Although the selection report provides overall project requirements and restrictions regarding the applicable structures, the primary purpose is to document the possible structures and recommend the optimal structure to meet project requirements. Cost savings should be analyzed based on a project total cost, not a bridge cost specifically. For example, a \$1 million savings in the bridge should not lead to a \$2 million increase in project costs. Ideally, structures with the highest rank should be adopted for detailed design, and the rest can be used as design alternatives. The Structure Selection Report shall document, justify, and explain Project Structural Engineers' structure layout and type selection. If the Designer anticipates the need for the refined method analysis, this should also be documented in the Structure Selection Report (refer to Section 4.1 for information on refined analysis requirements).

If the structure selection process indicates two options are not definitive in the recommended solution, two designs may be shown in the bid package. Providing two options as an ad alternative provides more competition in the bidding process, as an example, concrete vs steel or precast concrete vs cast-in-place concrete. A Project Special Provision will need to be included in the specifications. Coordination with CDOT Unit Leader should be performed and approval obtained prior to proceeding with this option in addition to a discussion included in the Structure Selection Report.

For projects with multiple bridges or structures, common material may be summarized for the project as a whole and need not be repeated in each

Structure Selection Report unless there are bridge or structure-specific differences.

The Structure Selection Report for all structures shall be submitted to CDOT for review and comment by the Project Design Team. For structures that are part of Federal-Aid projects or National Highway System Projects, a Structure Selection Report shall also be submitted to the FHWA Division Bridge Engineer. Allow at least two weeks before the FIR meeting or as scheduled otherwise for report review in the project schedule.

Appendix 2A includes the Structure Selection Report Checklist that shall be used as a general guideline for Designers as to what topics to consider when writing Structure Selection Reports. This list may not be all inclusive for topics that affect the structure selection. If items are not applicable that may be left from the report and the overall report shortened.

Staff Bridge Unit Leaders or designees are to use the checklist during their QA process. After the process is completed, the Staff Bridge Unit Leader will sign the provided Structure Selection Report QA Checklist to acknowledge approval and to document in writing an acceptance of the recommended structure type, layout, and all design deviations from CDOT Structural Standards. This should be done before FIR documents are submitted to the Region. The structure type in final design should match the Structure Selection Report. Otherwise, amendment to the report or a revised report shall be submitted before FOR for approval.

Structure selection includes the following steps:

1. The Design Team evaluates all feasible alternatives through discussion, tables, supporting drawings, etc., and prepares the Structure Selection report. It is recommended to meet and discuss the bridge with Staff Bridge and Region representatives.
2. Report undergoes QA/QC procedure before being submitted.
3. The Design Team submits the Structure Selection Report to the CDOT Unit Leader for review. CDOT Unit Leader performs review of the Report and signs off on the Structure Selection Report QA Checklist to acknowledge approval.
4. Structure Selection Report is submitted to the Region and to the FHWA Division Bridge Engineer (if applicable) for review and acceptance.
5. The Design Team updates Structure Selection Report as required per final geotechnical and hydraulics reports.

2.10.2 Major Structures

The definition of the term *Major Structures* is found in the Policies and Procedures section of this BDM.

2.10.2.1 Bridges

Different span arrangements and appropriate superstructure types should be evaluated and findings presented in the Structure Selection Report. Site

conditions, phasing, bridge length, and required minimum horizontal and vertical clearances will influence most decisions. The following are other factors that shall be considered during the preliminary design phase:

- Construction cost
- Life cycle cost
- Possible future widenings
- Ultimate roadway section below
- Capacity of girders during phase construction
- Speed of construction and maintenance

Refer to Appendix 2A, Structure Selection Report Checklist, for more criteria to be considered.

Adherence to the span-to-depth ratios in accordance with AASHTO Table 2.5.2.6.3-1 (Traditional Minimum Depth for Constant Depth Superstructures), is not required but the table is a good starting point for preliminary design.

**AASHTO
2.5.2.6.3**

In the Structure Selection Report, the Designer shall evaluate, confirm, and document the stability of the existing bridge when it is used in a partial width configuration as part of the new construction phasing. A separate rating may be required for the configuration of the existing bridge during phased construction to verify sufficient load capacity.

2.10.2.2 Culverts

A culvert is considered a major structure if its total length is greater than 20 ft. measured along the center of the roadway between the inside faces of the outside walls or spring lines of arches. It may also include multiple pipes where the clear distance between the centerlines of the exterior pipes, plus the radius of each of the exterior pipes, is 20 ft. or more.

A culvert is used in lieu of a bridge based on estimated construction and maintenance costs when viable hydraulically. Culverts may have a lower initial cost due to foundation conditions, shorter spans and shallower than bridges. In general, culverts have less aesthetic value and are potentially more damaging to streams than bridge structures, but much more durable and maintenance and inspection friendly. These factors should be considered when making a decision to choose a culvert over a bridge. Section 5.4.13 of this BDM outlines culvert design criteria.

2.10.3 Minor Structures

The Structure Selection Report for minor structures shall be provided with applicable sections. The definition of the term *minor structures* is found in the Policies and Procedures section of this BDM.

2.10.4 Wall Structures

The definition of the three categories of *walls*: retaining walls, bridge walls, and noise walls, is found in the Policies and Procedures section of this BDM.

2.10.4.1 *Retaining Walls*

The following considerations may affect the selection of a wall structure:

- Construction cost
- Spatial constraints
- Behavior constraints
- Constructability
- Maintenance
- Schedule
- Aesthetics (Corridor requirements)
- Environmental concerns
- Durability
- Scour Potential
- Available standard designs

The selection process shall be documented as evidence to support the decision. The wall Structure Selection Report shall be a stand-alone report with a cover letter, and site plan clearly indicating the names and locations of the walls.

For walls that support a highway and are affected by scour, the selection report shall document the cost of achieving stability for the 100 & 500 year scour compared to replacement cost. Structural engineer should discuss with the region for alternate criteria and resiliency requirements.

2.10.4.2 *Bridge Walls*

Bridge wall selection may be included in the Structure Selection Report for the bridge and not as a separate report if there are no additional retaining walls on the project. Selection considerations are the same as listed for retaining walls.

2.10.4.3 *Noise Walls*

Noise walls require a Structure Selection Report. Noise Wall discussions can be a standalone document or included in the Environmental Concerns portion of the Bridge or Wall Structure Selection Report. Refer to Chapter 18 of the CDOT Roadway Design Guide for additional noise wall requirements and discussion.

2.10.5 Overhead Sign Structures

Overhead sign structures do not require a Structure Selection Report unless requested by the Project Manager.

2.10.6 Tunnels

The definition of the term tunnels is found in the Policies and Procedures section of this BDM.

2.10.6.1 *Tunnels*

Tunnels can typically be constructed with several different methods such as: bottom up or cut and cover, top down, and use of boring machines. The Structure Selection Report shall evaluate the various methods of construction and any other criteria that may affect their design, maintenance, and construction. Site conditions, phasing, span, length, and required minimum horizontal and vertical

clearances will influence most decisions. The following are other factors that shall be considered during the preliminary design phase:

- Construction cost
- Life cycle cost
- Possible future widenings
- Phase construction impacts
- Speed of construction and maintenance
- Construction methods
- Emergency egress
- Need for air recirculation

2.10.7 Accelerated Bridge Construction

The Accelerated Bridge Construction (ABC) design and construction method uses several technologies to facilitate accelerated construction, such as rapid embankment construction, prefabricated bridge elements, various structural placement methods, fast track contracting, etc. This method of design and construction usually results in an overall decrease in construction time when compared to the historic construction methods used to build bridges. The ABC Matrix shall be evaluated and included in the Structure Selection Report for all structures. For more details, refer to Section 39 of this BDM and to the [FHWA Accelerated Bridge Construction Manual](#).

2.10.8 Life Cycle Cost Analysis

The structure selection process may consider the life cycle cost analysis (LCCA), which tracks cost values that cover the full cycle of the structure from the initial design to the end of the analysis period. The Designer shall assume all new bridges will last 100 years if all requirements are followed. Since approximately 1990, CDOT has been performing the LCCA and has tracked many cost factors. The following represent some of the factors engineers should determine:

- Design cost
- Construction cost
- Traffic control cost
- Maintenance cost
- Rehabilitation cost
- User cost

For recommended default cost values to be used for CDOT projects, refer to the latest [Cost Data](#) books published by CDOT and available online. For appropriate interest rate values refer to the latest CDOT pavement design manual available online.

2.10.9 Aesthetics

Aesthetic value shall be evaluated in a structure selection process for high profile structures and structures with corridor aesthetic requirements.

2.11 HYDROLOGY AND HYDRAULICS

2.11.1 Drainage Report Requirements

Hydraulic analysis and the Drainage Report shall meet requirements of AASHTO and the CDOT [Drainage Design Manual](#). The format of the Drainage Report is expected to vary based on a project's needs.

2.11.2 Scour

Scour shall be considered when designing any structure located in a streambed or impacted by streamflow. All bridges should be designed to withstand 100-year and 500-year storm scour events without failing. Design for 100-year storm shall be performed at the service and strength limit states, and 500-year storm scour shall be considered only for the extreme event limit state analysis. The General Layout and Hydraulics sheets shall show scour limits, elevations, and velocities of these storm events. If the 500-year flow would overtop the structure, the Designer should determine the appropriate AASHTO loads and groupings to apply during the stability analysis.

Walls that support the highway should be designed to withstand 100-year and 500-year storm scour events without failing unless approved by CDOT Resident Engineer/ Region. Region will evaluate the resiliency requirements for retaining walls.

Based on FHWA's model study, in instances where neither contraction scour nor general degradation is expected to be significant, there is no benefit to be gained from reducing local scour by placing the top of the footing supported by piles at an elevation other than flush with the streambed. As a rule, the disturbance of the streambed beyond the level described herein is discouraged.

Where substantial scour is predicted, the piles with pile caps may be designed to place the top of the pile cap below the estimated contraction scour depth where practical.

**AASHTO
2.6.4.4.2**

In general, spread footing foundations shall not be used for stream crossings. However, when shallow scour-resistant bedrock is present, spread footings may be considered as a foundation option provided they are embedded 6" min. into the bedrock. When considering this approach, Designers should consult with the project geotechnical and hydraulic engineers to evaluate the suitability of the bedrock present and get written approval from CDOT Unit Leader. When spread footings are placed into rock the sides of the footing should not be formed and then backfilled but should be placed to the rock.

Outlet Scour Protection and Roadway Overtopping & Revetment for culverts, which is covered in the CDOT Drainage Design Manual, is a hydraulics design issue and uses different criteria and definitions than typical bridge scour. The Structural Designer should coordinate with the hydraulic designer to make sure adequate requirements are met.

2.11.3 Deck Drainage Requirements

All bridges shall be investigated for drainage requirements. Bridge deck shall be kept watertight and deck drains should be placed at the interval required by design to intercept water surface and keep it away from expansion devices and

bearings. Special attention for deck drainage is needed for decks with super elevation transitions. The FHWA publication, Design of Bridge Deck Drainage, Hydraulic Engineering Circular No. 21 (HEC-21) (Publication No. FHWA-SA-92-010, May 1993), shall be used for the design of bridge drainage systems. The hydraulic design frequency shall be 5 years rather than the frequencies specified in HEC-21. The structural engineer shall coordinate with the Hydraulics Engineer and Environmental Scientist to create appropriate details and required spacing of drains as needed to meet their requirements.

Water exiting bridge drains shall not flow onto girder flanges, bearings, pier caps, abutment caps, roadways, railroad templates, or pedestrian/bikeways. Pipe drains, scuppers, and grated inlet drains shall extend below bottom of girders to assure that drainage is kept off steel girder flanges. If possible, drains should not be positioned above riprap. When drains must be placed over riprap, special filter fabric shall be placed under the riprap. This filter fabric shall be highly permeable and non-biodegradable. The bridge designer should coordinate with the Hydraulics Engineer and show an appropriately sized energy dissipater at the bottom of the bridge drain system to minimize scour.

Curb drains and pipe drains require approval from the CDOT Environmental Department. When allowed, curb drains shall provide a continuous curb for wheel impact. When allowed, pipe drains shall have a minimum diameter of 8 in. and internal grates 2 in. below the surface or be covered by a grate designed for 16 kip wheel load. Inlet grates shall be removable for cleaning. Project-specific details shall be included.

Approach slab drains shall be provided on the high side of expansion devices located at the end of approach slabs. The purpose of the approach slab drain is to minimize flow over the joint. The approach slab drain should be detailed such that the approach slab drain is not affected from the anticipated bridge movement. The location and size of the approach slab drain shall be designed and coordinated with the roadway engineer and hydraulic engineer.

When a drain is placed within the limits of the sidewalk, it shall be pedestrian and bicycle friendly.

Cleanouts shall be added to any closed pipe run to facilitate easier cleaning by maintenance. These should be reviewed at FOR by maintenance personnel for concurrence with the detailing and locations.

2.12 BRIDGE SECURITY

The Structure Selection Report will include discussion and recommendations on providing security measures for all Major Structures defined by CDOT and FHWA as structures with national importance and needs for protection. The Designer will coordinate with Staff Bridge at the preliminary phase of the design to develop both operational and engineering solutions to the proposed security measures and to ensure that security solutions will be met in design, construction, and operation stages.

2.13 APPROACH SLABS

Approach slabs are used to improve rideability and mitigate problems with settlement of the bridge approaches relative to the bridge deck and shall be provided on all vehicular bridges, except as noted below, or unless approved by State Bridge Engineer.

Concrete approach slabs are not required on bridges with GRS abutments that do not have an expansion device, as differential settlement between abutment and roadway approach is not expected to be significant. Asphalt pavement approach should be installed to allow minor grade corrections.

Approach slabs are not required on pedestrian bridges unless the Owner requests them.

The Designer should evaluate the use of approach slabs on concrete box culverts with no or minimal fill cover based on settlement concerns. An alternate may be to utilize MSE fill in the roadway section adjacent to the culvert to deal with possible settlement issues.

In all cases, the concrete approach slab shall be anchored to the abutment. Approach slab notches shall be provided on all abutments, even if an approach slab will not be placed with the original construction (see Section 11 of this BDM for details). Refer to BDM Section 14 for expansion joint requirements.

Elevations of the approach slabs shall be coordinated with the roadway approaches to avoid misalignment and must be provided in the plans in accordance with Section 2.2.1.3 of this BDM.

Roadway drains shall be placed in approach slabs to prevent flows across the expansion joint. Bridge designer shall coordinate with hydraulic engineer to determine location, number and size of drain inlets.

2.14 PIGEON PROOFING

Bridge areas with inspection requirements (such as bearings, abutment and pier caps) and roadway/pedestrian areas (such as utility pipes above pedestrian trails and sidewalks) should be protected from bird droppings when requested by the region or Staff Bridge. Methods to minimize potential pigeon roosting and nesting areas include plates, grating, nets, spikes, electric systems, and wires. Bird control and nest removal shall be taken into consideration when planning long-term maintenance and inspections.

2.15 SPREAD FOOTING EMBEDMENT

Bottoms of spread footings shall be embedded below the local or regional frost depth, with a minimum embedment of 3 ft.

2.16 DAMAGE AVOIDANCE DETAILS

CDOT Structural Worksheets and practice contain many details categorized as "Damage Avoidance Details" (DAD) or best management practices. In most cases, these details are intended to provide added durability to the structures, but in some cases they are required for design considerations as well. The minimum requirements are shown on the current worksheets published on the

Staff Bridge website. As with any worksheet, designers may elect to improve on some of the shown details for project-specific requirements, but some changes will require CDOT Unit Leader and State Bridge Engineer approval as noted in the worksheets or within this Design Manual.

Common damage avoidance details such as the drip groove at the edge of the deck and wall copings are intended to minimize water damage and shall not be revised. The coping details shown in the worksheets for MSE walls in tight ROW situations are intended to deal with trickle flows and increase durability. This detail may be revised, especially if water is kept away from the walls using the preferred method of separate ditches and swales. The two longer straps at the top of MSE walls are a damage avoidance detail primarily for impact loads but also serve for seismic purposes. The detailing of the rail anchor slab over the MSE wall facing is a design detail intended to separate impact loads from the wall facing. Wall copings are primarily intended to stabilize block walls during seismic events. Shiplap panel joints with fabric backing are used to accommodate settlement issues as well as seismic issues. Geomembrane over the MSE prism has the dual purpose of controlling design loads and facing durability. The FRP Bar or stopper at the base of precast panel walls is a seismic detail. The use of a concrete footer for MSE wall facings is another damage avoidance detail that will require approval to remove.

2.17 DISSIMILAR METALS

Dissimilar metals in contact with each other shall be avoided if possible. Electrolytic isolation shall be provided to prevent contact of dissimilar metals. Dissimilar metal-to-metal or aluminum-to-concrete post or rail installations shall have contact surfaces separated by an approved protective coating. Protective Coating shall be approved by SME. Asphaltic paint shall not be permitted to remain on surfaces to be exposed or to receive a sealant or paint.

APPENDIX 2A - STRUCTURE SELECTION REPORT QA CHECKLIST

(An interactive PDF Form version of the
Checklist is available on CDOT website)

Structure Selection Report QA Checklist

This checklist is to serve as quality assurance of the structure selection process. The sections in the report need not be in the same order as this checklist. This checklist must be signed by Staff Bridge Unit Leader or designee prior to submittal of FIR documents to the Region.

Structure Number(s): _____

Cover Sheet

- Name of the Project and Site Address
- Structure Number(s)
- Property Owner Name and Contact Information
- Report Preparer Name and Contact Information
- Submittal and Revision Dates as Applicable

Executive Summary

- Project Description
- Structure Recommendations

Site Description and Design Features

- Existing Structure(s) N/A: _____
- Vicinity Map N/A: _____
- ROW Impact N/A: _____
- Traffic Detour N/A: _____
- Constructability & Construction Phasing N/A: _____
- Utilities N/A: _____
- Geotechnical Summary N/A: _____
- Hydraulics Summary N/A: _____
- Environmental Concerns N/A: _____
- Roadway Design Features
 - Cross Section
 - Vertical Alignment
 - Horizontal Alignment

Structural Design Criteria

- Design Specifications
- Loading N/A: _____
 - Collision Load
 - Earthquake Load
- Deck Drainage N/A: _____
- Aesthetic Requirements N/A: _____
- Possible Future Widening N/A: _____

Structure Selection

- Selection Criteria
- Rehabilitation Alternatives N/A: _____
 - Inspection Summary
 - Load Testing Requirements N/A: _____

Add figures/sketches to the following sections as needed:

- Structure Layout Alternatives
 - Vertical Clearances
 - Horizontal Clearances
 - Skew

- Span Configurations
- Superstructure Alternatives N/A: _____
 - Concrete Girder Alternatives
 - Steel Girder Alternatives
 - Deck Drains
- Substructure Alternatives N/A: _____
 - Abutment Alternatives (GRS, Integral, Semi-integral, etc.)
 - Pier Alternatives
- Wall Alternatives N/A: _____
- Constructability & Construction Phasing
- ABC Design (include pre-scoping ABC rating results from spreadsheet found on the CDOT website)
- Maintenance and Durability
- Corrosive Resistance
- Summary of Structure Type Evaluation Table
- Construction Costs (including costs of alternatives)

Other

Figures and Appendices

- Alternative Typical Sections (if not provided in the report)
- General Layout of the Selected Structure
- Summary of Quantities and Cost Estimate Tables

List of Variances

Requested Variance: _____

Approved? Yes No

Requested Variance: _____

Approved? Yes No

Requested Variance: _____

Approved? Yes No

If you need more space, use an additional sheet(s) of paper.

CDOT Staff Bridge Quality Assurance Sign-off

By signing this checklist Staff Bridge Unit Leader acknowledges approval of the Structure Selection Report findings, recommendations, and all design deviations from the CDOT Structural Standards and design criteria.

Print Name	Signature	Date
------------	-----------	------