



# Topsoil Testing Procedure

This procedure provides Storm Water Management Plan (SWMP) designers with direction on how to plan, collect, and ship topsoil sample(s) to a recommended laboratory. Site depth inventories and laboratory testing provide critical data to determine the topsoil management strategy and topsoil amendment requirements during the design phase. Contact the Landscape Architecture Section with any questions.

## Presampling Planning

Topsoil inventory and field collection can occur year-round but requires pre-planning. The first step is to make a preliminary determination of the number of revegetation units within the project's Limits of Disturbance Area (LDA).

Revegetation units are areas with distinctly different topsoil characteristics based on both field observation and measurements and soil data (geotechnical report or Natural Resources Conservation Service (NRCS) Web Soil Survey). Most projects will only have one revegetation unit. Large projects with greater landscape diversity may have more than one revegetation unit. SWMP Designers should consider the following to determining the number and boundaries of revegetation units for the project:

- significantly different existing topsoil characteristics and depths
- microclimates
- vegetation types
- slope gradient and aspect
- drainage patterns
- constructability to segregate topsoil stockpiles

As early in the design process as possible, the SWMP designer should discuss with regional environmental staff the proposed number of revegetation unit(s) on the project. Each revegetation unit requires a separate composite sample and laboratory testing.

If the topsoil from different project locations will be combined into one stockpile, then only one composite sample is required. If the project has work areas separated by large distances, then each work area should be identified as a revegetation unit and will require separate composite samples.

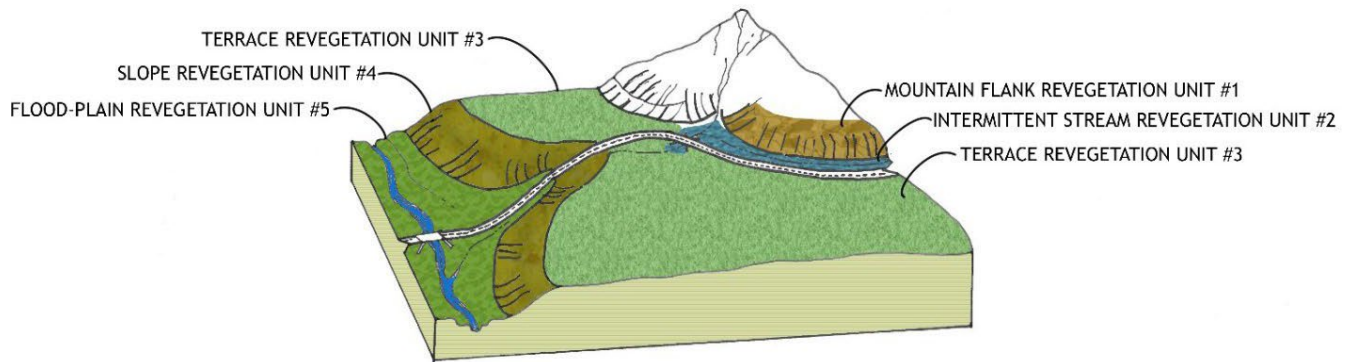

**Image 1.** Illustration of Potential Revegetation Units

Prior to collection, determine where you are sending samples and post office hours. Have overnight box and mailing label ready. Soil samples should be shipped for overnight delivery on the same day as collected. It is important to keep samples cool during warm weather. The nitrogen results can change dramatically if the samples overheat. Therefore, keep samples in the shade or in a cooler with ice to help prevent excessive heating.

### **Supplies you will need for collection:**

- mailing box with pre-addressed label
- one-gallon plastic bags
- sharpie
- clean, rust-free spade shovel (do not use galvanized or brass implements)
- clean bucket
- soil knife with depth markers (a clean utility or putty knife will also work)
- cooler to keep samples cool
- document topsoil depth at each revegetation unit and litter and duff

### **Field Inventory and Collection Procedure**

For most projects, a composite sample from each revegetation unit will provide an accurate representation of the site topsoil. The composite sample minimizes testing costs.

If the determined soil management strategy is to salvage and stockpile on-site, the locations of the soil pits and depths of topsoil should be shown in the SWMP Initial Site Maps.



## Topsoil Depth Inventory

Conduct a topsoil depth inventory by digging six (6) assessment pits within each revegetation unit. Using a clean rust-free spade or shovel, dig each pit. Overall pit depth is based on the visual indicators of the existing topsoil layer depth, and it should range in depth from one (1) inch to six (6) inches. Repeat the depth inventory procedure for each vegetation unit.

Once the depth inventory is completed and the areas of anticipated disturbance are determined, an estimate of the amount of available topsoil can be calculated. A revegetation best practice is to redistribute topsoil at a depth equal to or greater than the topsoil horizon of the undisturbed site. Because the majority of CDOT projects will have additional pavement after completion, CDOT's standard is to redistribute topsoil at a 6-inch depth. If sufficient topsoil quantities are not available, reduce the depth of topsoil redistributed to a minimum of 2-inch depth and document on the plans and specifications.

**Color** - An indicator of topsoil is the brownish or darker colors that occur near the surface. When the tones lighten or a distinct color change occurs, it generally indicates topsoil has ended. Moisture darkens the soil, therefore conditions after precipitation may make identification more difficult.

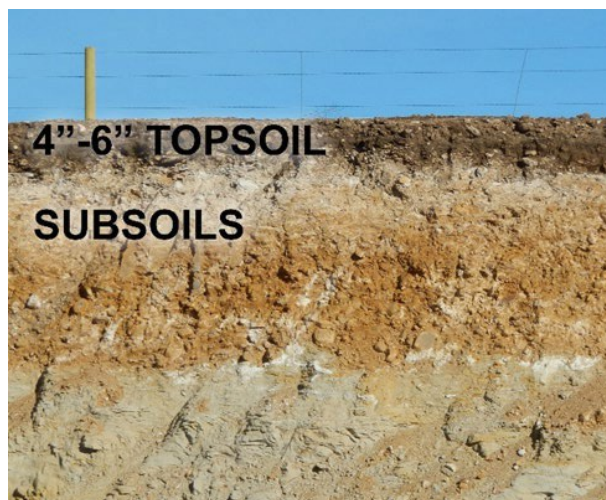

**Image 2.** Image illustrates the distinct color differences between topsoil and subsoil

### Topsoil Structure and Texture

Topsoil has a more balanced texture than the subsoil material. Topsoil layers have consistent textures. Subsoils, especially in high clay conditions will have an irregular blocky appearance.

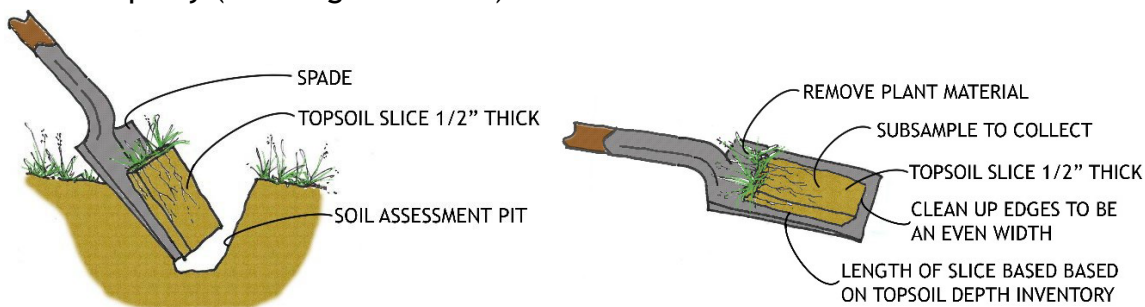

**Image 3.** Image shows the visually distinct texture and structure differences between topsoil and subsoil. Note the litter and duff layer.

As part of inventorying topsoil depths for the revegetation unit, the designer should also identify and note if the topsoil surface contains areas of litter and duff. “Litter and duff” is the layer of fresh and decomposed needles and leaves covering the ground surface of forest and shrub plant communities. This organic material is a valuable source of seeds and nutrients for plant growth. Based on the site assessment of desirable or problematic preexisting plant species, the direction should be given to either stockpile litter and duff with the topsoil or dispose of it offsite. Document the topsoil management strategy for each of the revegetation units on the SWMP site maps.

## Sample Collection

- To collect a representative slice from each of the soil assessment pits, use the spade and cut a 1/2” thick slice, straight down and not angled, from the side of the soil pit. Evenly sample the topsoil based on the determined depth. For example, if the topsoil depth is six inches (6”), sample the entire six inches (6”) equally (see diagram below).



**Step One - Remove slice**

**Step Two - Prepare Slice**

**Image 4.** Illustration of soil sample collection



- Remove any plant material (leaves, twigs, etc.) from the sample.
- Place the six (6) samples from each assessment pit into a bucket and thoroughly mix with the shovel and break up the clods.
- Place approximately three (3) cups of the sample into a one-gallon zipper-seal plastic bag. This is the composite sample from the six assessment pits for the revegetation unit.
- Label the plastic bag with the name and telephone number of the SWMP designer/sample collector, revegetation unit #, project construction code and approximate Mile Marker Post.
- Repeat the soil sampling procedure for each vegetation unit. Use a separate plastic bag for each vegetation unit sampled.
- Keep samples cool by leaving in shade and/or place in a cooler with ice.

## **Sending Samples to Laboratory for Testing**

Use one of the three recommended laboratories as found on the instructions page of the excel topsoil calculator. Sample Forms are located on the second tab of the excel topsoil calculator. Complete the appropriate lab analysis form prior to shipping sample. Place form in the box with the bagged soil samples. Do not put form in soil sample bags.

All costs associated with shipment and testing will be the responsibility of the consultant developing the SWMP. Test results will be available in approximately 4 weeks. Allow for sufficient time to interpret the results and include topsoil amendment protocols on the Final Office Review (FOR) plans.

### **Recommended Laboratories**

**Colorado State University (CSU) Spur**  
Soil, Water, and Plant Testing Lab 4817  
National Western Dr.  
Denver, CO 80216  
soiltestinglab@colostate.edu  
970-491-5061

**Recommended Test:** Complete Soil Analysis (Test Code S1) and Sodium Adsorption Ratio (SAR) (Test Code S11)  
CSU Lab Form link: <https://agsci.colostate.edu/soiltestinglab/wp-content/uploads/sites/140/2023/04/Soil-Lab-Horticulture-Form-with-Test-Codes-and-Prices-Revised-04172023-Fillable.pdf>



**Example CSU Form:**

 <b>Colorado State University</b> <b>CSU SPUR</b> Department of Soil and Crop Sciences			<b>Soil, Water, and Plant Testing Laboratory</b> 4780 National Western Drive Denver, CO 80216 Email: soiltestinglab@colostate.edu Tel: 970 491-5061						
CDOT 5 digit Construction Code			<b>Horticulture Soil Sample Submittal Form</b>						
Report and Billing To			Sample Information						
Name: <b>Consultant Business Name and Contact</b>			Sampling Date:						
Address: <b>Consultant conducting topsoil sampling</b>			Mailing Date: <b>Fill in this entire section</b>						
City:	State:	Zip:	Sample Received Date:						
Email: <b>Consultant conducting topsoil sampling</b>			County:						
Tel: <b>Consultant conducting topsoil sampling</b>			Location GPS:						
Lab Number (Lab Use Only)	Sample ID	Sample Depth (inches)	Horticulture Crop					Test Code	Comments
			Lawn/Turf	Vegetable Garden	Flower Beds	Orchard	Trees		
	^	6"						X*	S1 + SAR, Texture
Fertilizer rate recommendations			Yes	<input checked="" type="radio"/> No					

\* Native grasses and forbs  
 ^ Use a separate line for each revegetation unit/sample submitted.  
 (Please refer to CDOT Topsoil Testing Procedure)



**Weld Laboratories**  
1527 1st Avenue  
Greeley, CO 80631  
<https://weldlabs.com/>  
970-353-8118

**Recommended Test: Complete Soil and Sat. Sodium Adsorption Ratio (SAR)**  
Weld Lab Form link: <https://weldlabs.com/soil-analysis-purchase-order.pdf>

**Example Weld Form:**

**WELD LABORATORIES, INC—Soil Analysis Purchase Order**

1527 1<sup>st</sup> Ave • Greeley Colorado 80631 • Phone: (970) 353-8118 • Fax: (970) 353-1671 • info@weldlabs.com

Sample Submitted by Consultant Business Name and Contact  
 Street Consultant conducting sampling P.O. Box \_\_\_\_\_  
 City/State/Zip \_\_\_\_\_ Phone: Consultant conducting topsoil sampling  
 Grower's Name CDOT 5 digit Construction Code Email: Consultant conducting topsoil sampling

Sample ID	Sample ID	Sample ID	Sample ID
^ Use a separate line for each revegetation unit/sample submitted. (Please refer to CDOT Topsoil Testing Procedure)			
Acres	Acres	Acres	Acres
Lab No.	Lab No.	Lab No.	Lab No.

Test Required					
Routine	<input type="checkbox"/>	Routine	<input type="checkbox"/>	Routine	<input type="checkbox"/>
Essential	<input type="checkbox"/>	Essential	<input type="checkbox"/>	Essential	<input type="checkbox"/>
Complete	<input checked="" type="checkbox"/>	Complete	<input type="checkbox"/>	Complete	<input type="checkbox"/>
Other		Other		Other	
Liming and Soil Classification					

Recommendation	Proposed Crop	Proposed Crop	Proposed Crop	Proposed Crop
Yield Goal	Yield Goal	Yield Goal	Yield Goal	Yield Goal
N Credits (lbs/acre)	N Credits (lbs/acre)	N Credits (lbs/acre)	N Credits (lbs/acre)	N Credits (lbs/acre)
Manure/Compost: Previous Crop: Irrigation water:	Manure/Compost: Previous Crop: Irrigation water:	Manure/Compost: Previous Crop: Irrigation water:	Manure/Compost: Previous Crop: Irrigation water:	Manure/Compost: Previous Crop: Irrigation water:
Irrigated <input type="checkbox"/> Dryland <input checked="" type="checkbox"/>	Irrigated <input type="checkbox"/> Dryland <input type="checkbox"/>	Irrigated <input type="checkbox"/> Dryland <input type="checkbox"/>	Irrigated <input type="checkbox"/> Dryland <input type="checkbox"/>	Irrigated <input type="checkbox"/> Dryland <input type="checkbox"/>
Recommendations Yes <input type="checkbox"/> No <input checked="" type="checkbox"/>	Recommendations Yes <input type="checkbox"/> No <input type="checkbox"/>	Recommendations Yes <input type="checkbox"/> No <input type="checkbox"/>	Recommendations Yes <input type="checkbox"/> No <input type="checkbox"/>	Recommendations Yes <input type="checkbox"/> No <input type="checkbox"/>

Routine	Nitrate, phosphorus, potassium, pH, organic matter, salts, calcium, zinc, sulfate & texture estimation	Other Tests	CEC by exchange, CEC by summation, base saturation, ammonia, magnesium, sodium, chloride, liming requirement, full texture determination, subsoil nitrate, nematodes, SAR, CaCO <sub>3</sub> -C%
Essential	A routine test plus copper, iron & manganese		
Complete	An Essential test plus boron		

Sampling procedures can affect the value of analytical results – customers are advised to use appropriate sampling protocol to ensure samples are truly representative of the field.

