



COLORADO
Department of Transportation

2019

Erosion Control and Stormwater Quality Field Guide



Perimeter
Control

Exposed
Areas

Slopes

Ditches

Inlet/Outlet
Protection

Sediment
Traps

Pollution
Prevention

Special
Conditions

Colorado Department of Transportation

Contact Phone Numbers

CDOT Illicit Discharge Hotline (303) 512-4426
or 303-513-3927

CDPHE Environmental Emergency

Spill Reporting Line.....(887) 518-5608

Colorado State Patrol

24-hour hotline(303) 239-4501

Other Resources Available

CDOT Water Quality Program - Web Page

<https://www.codot.gov/programs/environmental/water-quality>

CDOT Landscape Architecture Section – Web Page

<https://www.codot.gov/programs/environmental/landscape-architecture>

CDOT Approved Products List –Web Page

<https://www.codot.gov/business/apl>

Erosion Control and Stormwater Quality Guide

<https://www.codot.gov/programs/environmental/landscape-architecture/erosion-storm-quality>

CDPHE Low Risk Discharge Guidance Discharges of Uncontaminated Groundwater to Land

<https://www.colorado.gov/pacific/sites/default/files/WQ%20LOW%20RISK%20GW.pdf>

Erosion Control and Stormwater Quality Field Guide

This guide is designed to provide guidance for permit and CDOT specification compliance in designing, installing, and maintaining control measures to minimize water quality and quantity impacts from stormwater runoff.

The material in this guide may have been updated after the printing. It is the responsibility of the user to verify that the project specifications and standard details are current.

Cover Photo: US 50 in CDOT Region 2, along the Arkansas River

Clean Runoff Starts with You

This guide is a reference for installers, Transportation Erosion Control Supervisors (TECS), and inspectors of erosion and sediment control and pollution prevention control measures on construction sites. The guide contains information on common control measures and is divided into several chapters— Perimeter Controls, Exposed Areas, Slopes, Ditches, Inlet and Outlet Protection, Sediment Traps, and Pollution Prevention. For quick reference, “thumbs up” and “thumbs down” icons have been added to pictures to indicate if the control measure shown is a good or bad example of proper installation and maintenance.

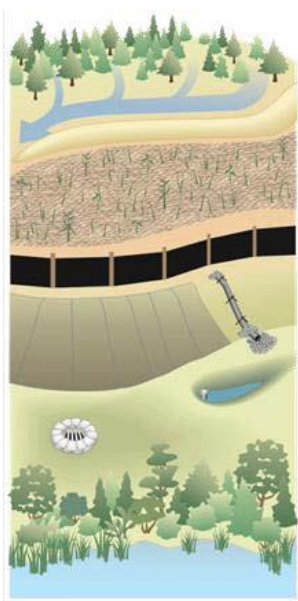

TECS Planning Objectives:

Prior to the start of any ground disturbances:

- Review the project Stormwater Water Management Plan (SWMP).
- Study the existing drainage patterns of the project site drainage basin. Identify all potential run-on and project site outlets along with anticipated flows.
- Submit a list of Potential Pollution Sources and a Spill Response Plan.
- Provide TECS certifications at the Environmental Pre-construction Conference (h2o.codot.gov).
- Establish the initial Areas of Disturbance (AD) on the SWMP Initial Site Maps.
- Install control measures identified in the Narratives Section of the SWMP as required.

During site construction:

- Attend meetings and review schedules to determine when to implement the control measures shown on the SWMP Interim Site Maps.
- Submit a method methodology for containing pollutant byproducts 10 days prior to starting concrete work (including existing concrete demo).
- Understand how the implementation of the project construction activities will affect drainage patterns and the need for continual control measure adjustment.
- Perform inspections.

During permanent stabilization actions:

- Attend a Site Pre-vegetation Conference if requested.
- Complete the work as shown on the Permanent Stabilization Site Maps, and update the SWMP as needed.

Final acceptance:

- Remove elements of the Concrete Washout areas and aggregate Vehicle Tracking Pads.
- Verify completion of all required items prior to requesting partial acceptance from 208.10.
- Attend the Stormwater Completion Walkthrough to inspect permanent stabilization work.
- Complete all punch-list items from walkthrough, including the removal of temporary control measures.
- Continue to perform inspections until final acceptance and transfer of the permit is completed.

Keys to being a SUCCESSFUL Transportation Erosion Control Supervisor (TECS)

Engage in Frequent Communication

A successful TECS will constantly and effectively communicate with the CDOT Project Engineer (PE), Superintendent, and Project Team. The TECS will follow specifications developed by CDOT, including ensuring that the PE signed inspection and audit reports are always completed, attending stormwater-related weekly team meetings, and ensuring that the PE and Superintendent are present during the pre-construction meeting with the CDOT Regional Water Pollution Control Manager and subcontractor.

Use available inspection tools

Properly identifying pollutants on a project, as well as choosing, installing, and maintaining the appropriate control measures to minimize the potential for contamination to State Waters or offsite areas, is the backbone of stormwater management. Valuable tools such as The Gauntlet are available to TECS for guidance to ensure field compliance throughout the duration of the project.

Be Proactive

The TECS must ensure that the appropriate control measures are correctly installed **before** the site is exposed to pollutants. Properly planning control measures **before** construction starts will prevent the use of a reactive approach and will **increase** the chances of having a successful project. Being proactive will improve communication with the owners, contractor, and subcontractors; it may reduce project costs, and it will promote regulatory and permit compliance.

The Gauntlet

The Gauntlet is an easy way to inspect the appropriateness and proper installation of a control measure. A good practice is to start at an outfall and use The Gauntlet as you move backwards through a treatment train to determine potential problem areas.

THE GAUNTLET

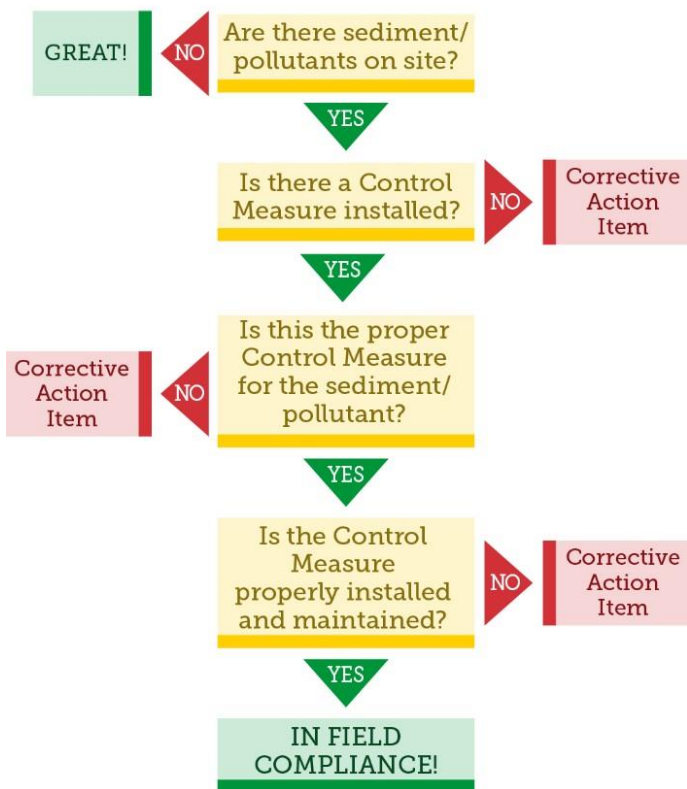

Environmental Permits

All construction sites require stormwater control measures. Construction sites that disturb 1 or more acres, with limited exceptions, require permit coverage under the Colorado Discharge Permit System/Stormwater Construction Permit. Construction sites that include dewatering may require a Dewatering Permit (refer to Colorado Department of Public Health and Environment's [CDPHE] [Low Risk Discharge Guidance Document of Uncontaminated Groundwater to Land](#)).

These permits are administered by CDPHE. To download CDPHE's forms to obtain coverage under these permits visit:

<https://www.colorado.gov/pacific/cdphe/wq-construction-general-permits>

A SWMP is a requirement for all CDOT construction sites. The SWMP includes control measures to prevent pollution that results from construction and activities such as vehicle maintenance, hazardous waste storage, sanitary waste facilities, and fueling operations.

Why Do We Need to Control Erosion and Sediment Losses from Construction Activities?

Erosion control is desirable not only for environmental reasons but also for highway safety purposes. Uncontrolled erosion during highway construction, and subsequent sedimentation, could potentially cause adverse impacts on streams, damage to drainage

structures and public or private lands, and public criticism. When installed correctly, control measures minimize soil erosion that prevents sedimentation into nearby State Waters. Remember that stormwater is not treated before being discharged into State Waters. State Waters are defined to be any and all surface and subsurface waters that are contained in or flow through the state, including streams, rivers, lakes, drainage ditches, storm drains, groundwater, and wetlands. Waters in sewage systems, treatment works or disposal systems, potable water distribution systems, and all water withdrawn for use until they are used and/or treated are not considered State Waters. Control measures can also minimize the need for corrective measures.

Erosion and Sediment Control Strategies

The best strategy is to address erosion control as the primary measure and sediment control as the secondary measure. Erosion control reduces the amount of soil transported by runoff and wind as a result of construction disturbance. Sediment control captures the soil that has been eroded before it leaves the construction site. Effective implementation of erosion control measures will reduce maintenance and prevent potential sediment discharges.

Tips

- Phase construction activities to minimize the total amount of soil exposed.
- Minimizing potential pollution is more useful and effective compared to pollution removal.
- Use redundant control measures in series to minimize overloading and prevent potential failures.
- Limiting erosion reduces stress on sediment control measures.
- Use both erosion and sediment control measures on projects to prevent sediment discharges.
- Use temporary, interim, and permanent stabilization strategies on disturbed areas as soon as practical.

Maintain Your Control Measures

All erosion and sediment control practices and other protective measures identified in the SWMP must be maintained in effective operating condition at all times. Even though a project might be accepted and closed, the permits might still be open. Where control measures have failed, they must be addressed as soon as possible, immediately in most cases, to minimize the discharge of pollutants.

How to Keep Our Waters Clean

Prevent the discharge of pollutants into drainage systems such as ditches, curbs and gutters, storm drain inlets, streams, rivers, and wetlands. Contain potential pollutants on the construction site.

- Protect clean offsite water from running onsite and becoming contaminated with sediment or other pollutants.
- Minimize the disturbance of existing vegetation.
- Stabilize disturbed areas as soon as possible.
- Conduct inspections in accordance with Section 208.03. Record inspections on CDOT Form 1176 for 7-day inspections and after storm events.
- Inspect control measures on inactive construction sites (after acceptance of all punch-list items from the Stormwater Completion Walkthrough) at a minimum every 45 days. Record inspections on CDOT Form 1177. Document the inspections until the stormwater permits are inactivated (closed).
- Repair any control measures that have failed immediately.
- Always keep the SWMP documentation on the construction site and within the property of CDOT. Update the SWMP to reflect site conditions as soon as practicable, but in no case more than 72 hours after the change.
- Remove control measures that are no longer necessary (for example, remove silt fence

around an area that has achieved 70 percent of pre-existing vegetation).

The following items as approved by the PE are available for reference in the SWMP located in the CDOT project field office:

1. SWMP Plan Sheets
2. SWMP Site Maps
3. Project Specifications
4. M & S Standard Plans (Standard Details)
5. Weekly meeting notes
6. Calendar of inspections
7. Field inspection forms
8. Audit reports and Form 105(s) relating to water quality
9. Inspection and maintenance methods
10. Spill Response Plan
11. List of potential pollutants
12. Other documents (permits transfer to Maintenance Punch List and use agreements)
13. TECS Certifications
14. Environmental Pre-construction Conference documentation
15. All project environmental permits
16. Documentation of existing vegetation

More Information on Control Measures

The specifications for control measures included in a SWMP are listed in CDOT's Standard Specifications for Road and Bridge Construction (Sections 101, 107.25, 207, 208, 212, 213, and 216, and any special provisions the project may have), CDOT M & S Standards M-208-1, and SWMP details. In addition, information on control measures can be obtained from the CDOT Erosion Control and Stormwater Quality Guide. All documents can be downloaded from:

<http://www.coloradodot.info/programs/environmental/water-quality/documents>

Contact the TECS, Regional Environmental Staff, or PE if you have any questions about the SWMP or the installation and maintenance of control measures.

CDOT Standard Specifications for Road and Bridge Construction

CDOT Specifications can be downloaded from:

<https://www.codot.gov/business/designsupport/cdot-construction-specifications/2017-construction-standard-specs>

- Section 107.25 details practices that minimize water pollution during construction. This section also addresses who is responsible for any violations and fines.
- Section 207 details subgrade preparation along with topsoil salvage, storage, and distribution onsite.
- Section 208 details water quality control for construction sites and describes control measures and penalties for failing to control erosion.
- Section 209 details water application guidelines for landscaping and dust palliatives.
- Section 212 addresses seeding, fertilizer, soil conditioning, and sodding requirements on construction sites.
- Section 213 details mulching and spray-on mulch blanket requirements.
- Section 216 addresses soil retention covering and spray-on mulch blanket for erosion control on construction sites.

This page intentionally left blank.

Table of Contents

Contact Phone Numbers	i
Other Resources Available	i
Erosion Control and Stormwater Quality Field Guide	ii
Clean Runoff Starts with You	iii
TECS Planning Objectives:	iv
Keys to being a SUCCESSFUL Transportation Erosion Control Supervisor (TECS).....	vi
The Gauntlet.....	vii
Environmental Permits	viii
Maintain Your Control Measures	x
Chapter 1 Perimeter Control	
Perimeter Control	1-2
Construction Safety Barrier Fencing.....	1-2
Temporary Berms and Diversions	1-3
Silt Fence.....	1-7
Vehicle Tracking Pad.....	1-10
Chapter 2 Exposed Areas	
Exposed Areas	2-2
Surface Roughening.....	2-2
Mulching	2-3
Mulch Tackifier	2-5
Seeding	2-5
Chapter 3 Slopes	
Slopes	3-2
Tracking	3-2

Silt Fence or Other Barriers.....	3-4
Soil Retention Blankets	3-5
Spray-on Mulch Blankets	3-12
Temporary Slope Drain	3-13
Chapter 4 Ditches	
Ditches.....	4-2
Check Dam.....	4-2
Soil Retention Blankets and Turf Reinforcement Mats for Ditch Use	4-9
Chapter 5 Inlet and Outlet Protection	
Inlet and Outlet Protection.....	5-2
Inlet Protection.....	5-2
Outlet Protection	5-8
Chapter 6 Sediment Traps	
Temporary Sediment Traps.....	6-2
Chapter 7 Pollution Prevention	
Pollution Prevention	7-2
Concrete Washout Structure	7-2
Construction Site Liquid and Solid Waste Management.....	7-6
Spill Prevention and Control	7-8
Stockpile Management	7-12
Street Sweeping and Vacuuming	7-14
Chapter 8 Special Conditions	
Dewatering Structure.....	8-2
Steam Crossing.....	8-3

Chapter 1 Perimeter Control

Perimeter Control	1-2
Construction Safety Barrier Fencing	1-2
Temporary Berms and Diversions	1-3
Silt Fence	1-4
Vehicle Tracking Pad	1-10

Perimeter Control

Perimeter controls are used to control sediment-laden runoff from leaving a construction site and define the construction perimeter and/or sensitive areas. It is important that perimeter controls are in place before any earth-moving activities begin.

Construction Safety Barrier Fencing

Construction Safety Barrier Fencing (plastic fencing) should be used to protect wetlands and other sensitive areas from construction traffic.



This is an excellent example of Construction Safety Barrier Fencing. It is used here to prevent vehicles from damaging existing vegetation, minimize environmental impacts, and delineate active construction areas.

Temporary Berms and Diversions

A Soil Berm or Diversion is a temporary compacted ridge that slows and diverts stormwater from an open traffic area or slope. Clean Water Diversions are designed to intercept and divert upland and clean runoff around bare soil areas. Berms and Temporary Diversions strategically direct runoff through a construction site to reduce erosion and sedimentation problems. Remove Berms and Temporary Diversions after construction.

Tips

- Berms should have a minimum height of 18 inches, side slopes of 2:1 or flatter, and a minimum base width of 4.5 feet.
- Berms should be constructed out of subsoil and never out of salvaged topsoil.
- Do not use berms in high-traffic areas where they will be continually run over.
- Do not run Berms down a slope; watch for concentrated flows when the Berm directs water to one area.
- Do not use sand and gravel or debris-laden material to construct a Berm.
- Clean Water Diversions require approved project special provisions and details.

Maintenance

- Repair and inspect often for breaches.



This is an excellent example of a Temporary Berm. The soil is compacted and there are no breaks in the berm.

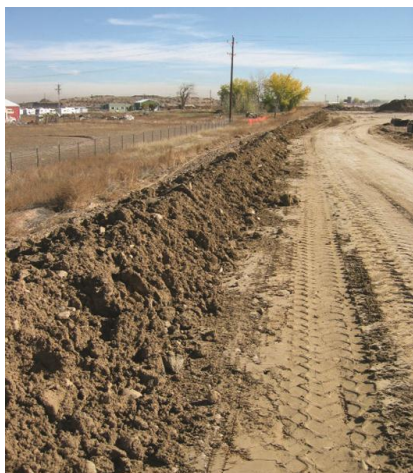

This is a poor example of a berm. The berm is not compacted.

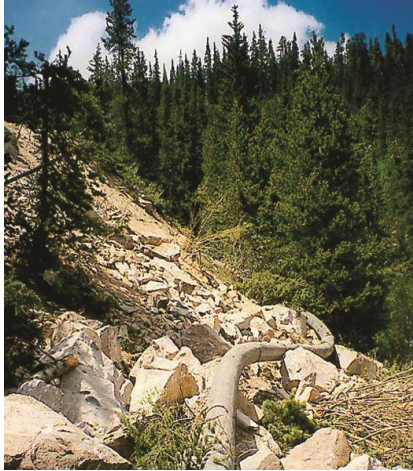

This is an excellent example of a Clean Water Diversion Pipe. The pipe should have a minimum capacity to convey the runoff expected from a 2-year frequency storm.



This is an excellent example of an open channel Clean Water Diversion. Riprap and PVC liner is used to minimize sediment in the water diverted through a construction site.

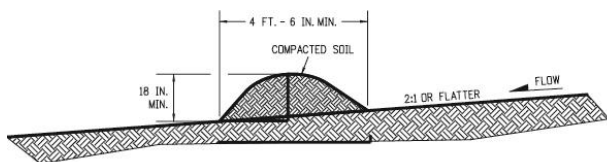

NOTES:

1. BERMS SHALL HAVE A HEIGHT OF 18 INCHES, SIDE SLOPES OF 2:1 OR FLATTER AND A MINIMUM BASE WIDTH OF 4 FT. - 6 IN.
2. BERMS SHALL BE USED TO INTERCEPT AND DIVERT DRAINAGE TO A DESIGNATED OUTLET.
3. BERMS SHALL NOT BE USED WHERE DRAINAGE AREA EXCEEDS 10 ACRES.
4. BERMS SHALL BE CONSTRUCTED OUT OF ACCEPTABLE MATERIAL THAT CAN BE COMPACTED AND RECEIVE AT A MINIMUM HEAVY EQUIPMENT WHEEL ROLLED COMPACTION.
5. TEMPORARY BERMS SHALL BE CONSTRUCTED OUT OF EMBANKMENT (SUBSOIL) AND IN NO CIRCUMSTANCE CONSTRUCTED OUT OF SALVAGED TOPSOIL.

TEMPORARY BERM

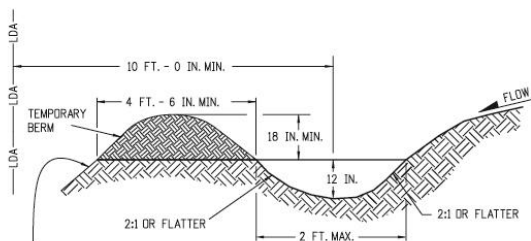

FOR BERMS TALLER THAN 2 FT.,
INSTALL TOE OF SLOPE CONTROL MEASURES.
SEE SHEET 3 OF 11 FOR DETAILS.

NOTES:

1. TEMPORARY DIVERSION DITCHES SHALL BE CONSTRUCTED ACROSS THE SLOPE TO INTERCEPT RUNOFF AND DIRECT IT TO A STABLE OUTLET OR SEDIMENT TRAP.
2. USE THE TEMPORARY DIVERSION DITCH IMMEDIATELY ABOVE A NEW CUT, FILL SLOPE, OR AROUND THE PERIMETER OF A DISTURBED AREA.
3. THE GRADIENT ALONG THE FLOW PATH SHALL HAVE A POSITIVE GRADE TO ASSURE DRAINAGE, BUT SHALL NOT BE SO STEEP AS TO RESULT IN EROSION DUE TO HIGH VELOCITY.
4. THE DIVERSION FLOWLINE SHALL ALWAYS BE LOCATED A MINIMUM 10 FEET FROM THE OUTSIDE LIMITS OF DISTURBED AREA BOUNDARY.
5. DIVERSION BERMS SHALL BE CONSTRUCTED OUT OF EMBANKMENT (SUBSOIL) AND IN NO CIRCUMSTANCE CONSTRUCTED OUT OF SALVAGED TOPSOIL.

TEMPORARY DIVERSION

Silt Fence

Silt Fences are used as temporary perimeter controls around sites where construction activities will disturb the soil. They can also be used around the interior of the site, such as at the toe of slopes or piles of fill. A Silt Fence consists of a length of filter fabric stretched between anchoring posts spaced at regular intervals. When installed correctly and inspected frequently, Silt Fences can be an effective barrier to sediment leaving the site in stormwater runoff.

Tips

- Install Silt Fence prior to any grubbing or grading activity.
- Install Silt Fence along contours to avoid concentrated flows. Concentrated flows could cause Silt Fence failure.
- Along the toe of fills, install Silt Fence along a level contour and provide an area behind the fence for runoff to pond and sediment to settle. Install Silt Fence approximately 5 feet away from the toe of the fill when feasible.
- Remove and dispose of sediment properly from behind the Silt Fence when it accumulates to half the exposed filter fabric height.
- Repair rips and tears.
- Do not exceed a maximum drainage area of 0.25 acre per 100 feet of Silt Fence length.
- Do not place Silt Fence in or adjacent to existing wetlands where trenching could impact the wetlands. Use Construction Safety Barrier Fencing (orange fencing) to protect wetlands.
- Do not install Silt Fence in or across State Waters.

- Silt Fence does not work well in rocky soils or where high winds are prevalent.
- Do not install across ditches or areas of concentrated flows.

Maintenance

- Staple and stake as needed.
- Remove Silt Fences when they have served their useful purpose.
- Stabilize disturbed area disturbed after the Silt Fence is removed.



Very good installation of Silt Fence. Good perimeter control to define work area. Existing plants are protected with Silt Fence and Safety Barrier Fence.



Poor maintenance of Silt Fence. Sediment should be removed



from behind the Silt Fence when it accumulates to half the exposed filter fabric height. Silt Fence should not be installed in State Waters.

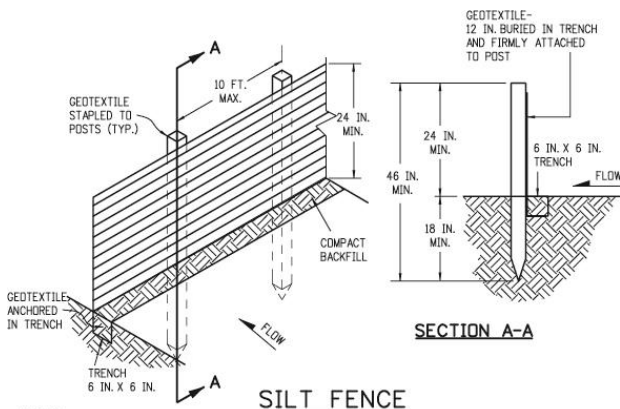

SILT FENCE

NOTES:

1. GEOTEXTILE SHALL BE ATTACHED TO WOOD POSTS WITH THREE OR MORE STAPLES PER POST. STAPLES SHALL BE HEAVY DUTY WIRE AND AT LEAST 1 INCH LONG.
2. WOOD POST SHALL BE 1 IN. X 1 IN. NOMINAL.
3. THE SILT FENCE SHALL BE PLACED ON THE CONTOUR (AT THE SAME ELEVATION ± 6 IN.). THE ENDS SHALL BE FLARED UP SLOPE (MINIMUM ELEVATION GAIN OF 18 IN.).

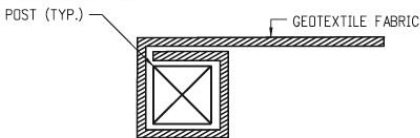

END SECTION DETAIL (PLAN VIEW)

NOTE:

1. THE END OF THE SILT FENCE FABRIC SHALL BE WRAPPED APPROX. 6 INCHES AROUND A WOODEN POST ONE FULL TURN, THEN SECURED ALONG THE POST WITH 6 HEAVY DUTY WIRE STAPLES AT LEAST 1 INCH LONG.

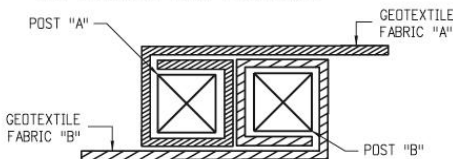

JOINING SECTION DETAIL (PLAN VIEW)

NOTES:

1. THE ENDS OF THE SILT FENCE FABRIC SHALL BE JOINED TOGETHER BY WRAPPING APPROX. 6 INCHES OF EACH END AROUND A WOODEN POST ONE FULL TURN, THEN SECURED ALONG THE POST WITH 6 HEAVY DUTY WIRE STAPLES AT LEAST 1 INCH LONG.
2. POSTS SHALL BE TIGHTLY ABUTTED WITH NO GAPS TO PREVENT POTENTIAL FLOW-THROUGH OF SEDIMENT AT JOINT.

Vehicle Tracking Pad

The purpose of a Vehicle Tracking Pad is to minimize the amount of sediment leaving the area as mud attached to vehicle tires. As a vehicle drives over the construction entrance control measure, it removes mud and sediment from the tires and reduces soil transport offsite. Geotextile fabric separates the gravel from the soil below, keeping the gravel from being ground into the soil. The geotextile fabric also reduces the amount of rutting caused by vehicle tires by spreading the vehicle's weight over an area larger than the tire width. Vehicle Tracking Pads can also be prefabricated, and pre-approved manufactured products can be found on CDOT's Approved Products List.

Tips

- Clean up mud or dirt tracked onto paved surfaces as needed.
- Replace damaged curb, gutter, or sidewalk.
- Make sure all vehicles use the Vehicle Tracking Pad.
- Replace and/or add aggregate as needed to prevent tracking mud and debris into the street.



An excellent installation of a Vehicle Tracking Pad and equipment access.



Poor installation of a Vehicle Tracking Pad. It is not 70 feet long. Refer to the table below for details.



Poor installation of a Vehicle Tracking Pad. It is not 70 feet long. Refer to the table below for details.



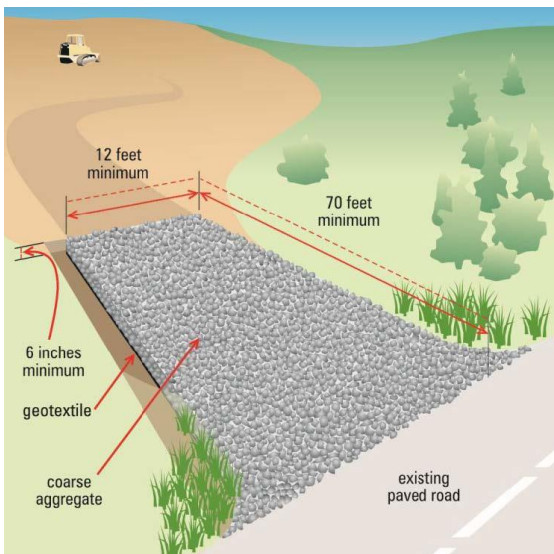

Vehicle Tracking Pad Aggregate Gradation Table

Sieve Size	Percent by Weight Passing Square Mesh Sieves
75 mm (3 inch)	100
50 mm (2 inch)	0 to 25
19 mm (0.75 inch)	0 to 15

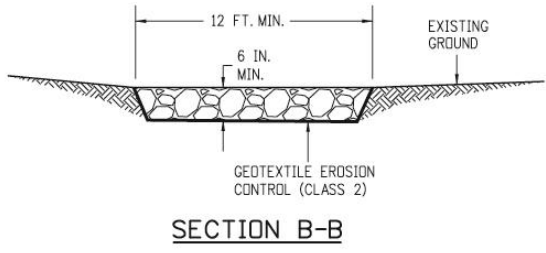
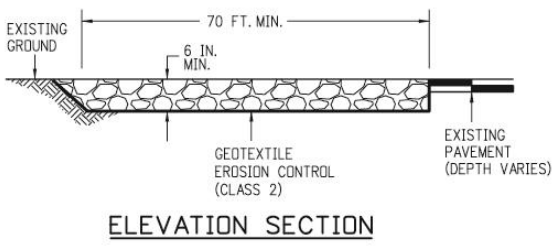
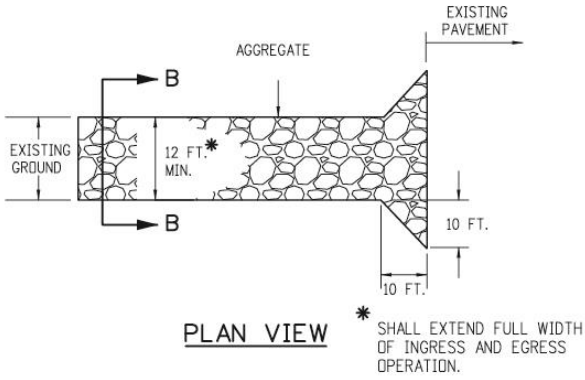

NOTES:

1. THE CONTRACTOR SHALL PROTECT CURB AND GUTTER THAT CROSSES THE ENTRANCE FROM DAMAGE, WHILE NOT BLOCKING FLOW OF WATER THRU STRUCTURE. PROTECTION OF THE CURB AND GUTTER SHALL BE INCLUDED IN THE COST OF WORK AND NOT PAID FOR SEPARATELY.
2. ALL MATERIALS AND LABOR TO COMPLETE THE VEHICLE TRACKING PAD SHALL BE INCLUDED IN THE COST OF WORK AND NOT PAID FOR SEPARATELY.

VEHICLE TRACKING PAD

This page intentionally left blank.

Chapter 2 Exposed Areas

Exposed Areas	2-2
Surface Roughening	2-2
Mulching.....	2-3
Mulch Tackifier.....	2-5
Seeding.....	2-5

Exposed Areas

According to CDOT Specifications, at the end of each day, the Contractor shall stabilize disturbed areas by surface roughening, vertical tracking, or a combination thereof.

Removing vegetation and topsoil can quickly result in erosion.

Surface Roughening

Surface Roughening may be accomplished by furrowing, scarifying, ripping, or disking the soil to create a 2- to 4-inch variation in soil surface. Surface Roughening is used as a temporary control measure to reduce the speed of runoff, increase infiltration, reduce erosion, trap sediment, and prepare the soil for seeding and planting by capturing moisture for seed.

Surface Roughening should be used along the contour of slopes. Surface Roughening is different than Tracking (see page 3-2).



Excellent example of Surface Roughening along the contour of the slope.



Mulching

Mulching is an erosion control practice that uses certified weed-free hay or straw for interim stabilization of slopes and exposed areas when work is halted for 14 days or more, or when seeding cannot occur because of seasonal constraints. Mulching can also be used for newly seeded areas as part of the permanent stabilization strategies.

Tips

- Apply mulch to a depth between 1 and 2 inches.
- Hay at 1.5 tons per acre is preferred to straw at 2 tons per acre.
- Anchor mulch by mechanically crimping the hay/straw followed by mulch tackifier.
- Do not apply mulch when windy conditions are present.



Excellent mulch application. Crimp forage mulch into loosened soil.



Excellent mulch application. Fibers should be crimped or disked into soil and should stand upright.



Poor mulch installation. Not enough mulch was applied, and it was not anchored to the soil, which left bare areas.

Mulch Tackifier

Mulch Tackifier is hydraulically applied and consists of either a *Plantago Insularis* or corn starch polymer used to hold mulch in place and minimize erosion from runoff and wind. Always use Mulch Tackifier on straw or hay mulched areas to hold mulch in place and prevent soil erosion caused by runoff and wind.

Tips

- Apply Mulch Tackifier within 4 hours of mulch applications.
- Do not apply during precipitation events, high winds, or over snow.

Seeding

Seeding is used to control runoff and erosion on disturbed areas by establishing vegetative cover. It reduces erosion and sediment loss and provides permanent stabilization.

Tips

- Prepare seed bed by loosening surface.
- Perform all drill seeding operations along the slope's contour.
- Provide seed tags to inspector.
- Inspect seed drill to ensure proper operation and placement of seed.
- Permanent stabilization requirements including soil amendments, Seeding, and Mulching must be completed within 4 days of placement of topsoil on finished grades.

- Re-seed an area if the seeded area fails to establish or provide adequate ground coverage or becomes disturbed.
- Conduct Seeding throughout the duration of the project as construction is completed.
- Only conduct Seeding during the seeding seasons listed in the Seeding table. Seeding outside the seasonal constraints may cause Seeding failures.



Prepare soil and, if required, incorporate topsoil or soil conditioning. Drill seed rows must be parallel to contours (along grade).

Seasonal Seeding Guidelines

Zone	Spring Seeding	Fall Seeding
<i>Areas other than the Western Slope</i>		
Below 6,000 feet	Spring thaw to June 1	September 15 until consistent ground freeze
6,000 feet to 7,000 feet	Spring thaw to June 1	September 1 until consistent ground freeze
7,000 feet to 8,000 feet	Spring thaw to July 15	August 1 until consistent ground freeze
Above 8,000 feet	Spring thaw to consistent ground freeze	
<i>Western Slope</i>		
Below 6,000 feet	Spring thaw to May 1	August 1 until consistent ground freeze
6,000 feet to 7,000 feet	Spring thaw to June 1	September 1 until consistent ground freeze
Above 7,000 feet	Spring thaw to consistent ground freeze	

This page intentionally left blank

Chapter 3 Slopes

Slopes	3-2
Tracking	3-2
Silt Fence or Other Barriers	3-4
Soil Retention Blankets	3-5
Spray-on Mulch Blankets	3-12
Temporary Slope Drain	3-13

Slopes

Slopes, especially steep and/or long ones, must be protected to prevent sheet, rill, and gully erosion. Slopes should be stabilized immediately after grading work is completed. Soil retention blankets are needed on most slopes steeper than 3:1, depending on soil types. Protecting slopes from erosion requires several actions that must be taken together. No single approach will be successful, especially if the slope is long, steep, or has highly erodible soils.

If slopes are broken up into benches or steps, runoff can be collected and diverted to channels that lead to a pipe or to open channel embankment protectors that have stable outlets.

Combine the following control measures with Seeding and Mulching to protect slopes. See the Seeding and Mulching control measures in the Chapter 2 for details and tips.

Tracking

Tracking involves roughening subsoils or embankment material with horizontal grooves using construction equipment. Tracking reduces runoff velocity, increases infiltration, and reduces erosion.



Tips

- Track the slope when grading work is completed.
- Track up and down the slope.
- Tracking does not work well in sandy soils.
- Do not track designated topsoil either spread out on the surface or in stockpiles.



Excellent examples of Tracking. Tracks are perpendicular to slope.

Silt Fence or Other Barriers

Silt Fence or other barriers should be installed approximately 5 to 10 feet from the toe of the slope or slightly away from the toe. Stagger fence sections to ensure total coverage. Repair as needed and remove when grass is well established. Erosion Logs, installed on the contour, may also work well to break up flows on long slopes.

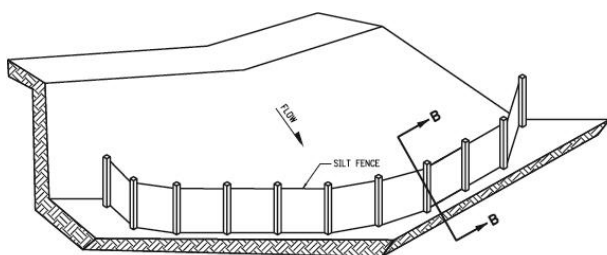

ISOMETRIC VIEW

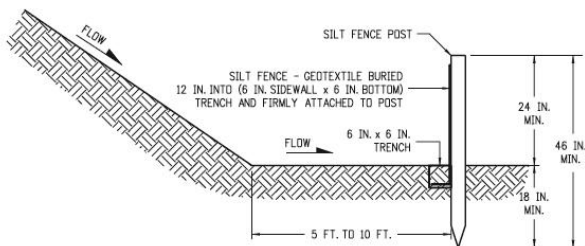

SECTION B-B

SILT FENCE TOE OF SLOPE PROTECTION

NOTES

1. SILT FENCE SHALL HAVE A MAXIMUM DRAINAGE AREA OF ONE-QUARTER ACRE PER 100 FEET OF SILT FENCE LENGTH; MAXIMUM SLOPE LENGTH BEHIND BARRIER IS 100 FEET.
2. SILT FENCE USED AT TOE OF SLOPE SHALL BE PLACED 5 TO 10 FEET BEYOND TOE OF SLOPE TO PROVIDE STORAGE CAPACITY.
3. SILT FENCE SHALL BE PLACED PARALLEL TO THE CONTOUR WITH ENDS FLARED UP SLOPE.
4. THE MAXIMUM LENGTH OF EROSION LOGS OR SILT FENCES WITHOUT A FLARED END TURNING UPSLOPE IS 150 FEET.

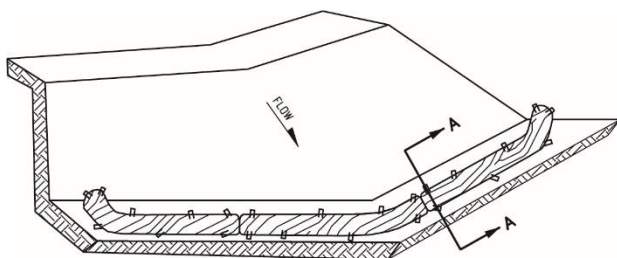

ISOMETRIC VIEW

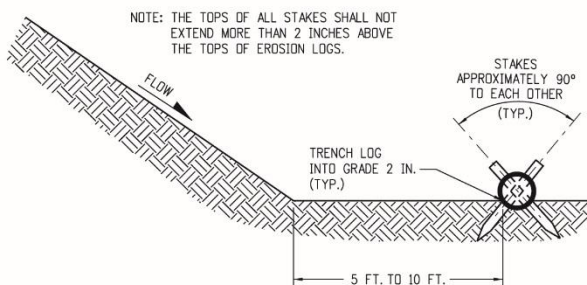

SECTION A-A

NOTES:

1. EROSION LOGS USED AT TOE OF SLOPE SHALL BE PLACED 5 TO 10 FEET BEYOND TOE OF SLOPE TO PROVIDE STORAGE CAPACITY.
2. EROSION LOGS SHALL BE PLACED ON THE CONTOUR WITH ENDS FLARED UP SLOPE.

EROSION LOG TOE OF SLOPE PROTECTION

Soil Retention Blankets

Protect steep slopes with Soil Retention Blankets. Soil Retention Blankets are placed on the soil in disturbed areas to control erosion, retain sediment resulting from sheet-flow runoff, and protect newly seeded areas. When properly applied, Soil Retention Blankets completely cover the ground surface. Blanket type is detailed in the Slope Treatment table.

Tips

- Make sure the disturbed area is uniform, with no large rocks, vegetation, or rilling on the surface, before placing blankets.
- Prepare areas where blankets are to be used with topsoil and soil conditioning, fertilize if required, and seed before the blankets are placed.
- Place blankets smoothly but loosely on the soil surface without stretching.
- Re-anchor loosened matting and replace missing matting and staples as required.
- Trench in blankets 6 inches wide by 6 inches deep at the top and bottom of the slope.
- Staple checks are required every 35 feet down the slope.
- To avoid undercutting, trench at the top of the slope beyond the crest of the slope (see Section 216 and M-216).

Slope Treatment

Condition	Blanket Type
Slopes 2:1 or steeper depending on soil type	Soil Retention Blanket
Erosive soil (sand) or slopes receiving sheet flow from roadway surface runoff	Soil Retention Blanket Turf Reinforcement Mat

CDOT Landscape Architects can provide more information on the appropriate types of Soil Retention Blankets.

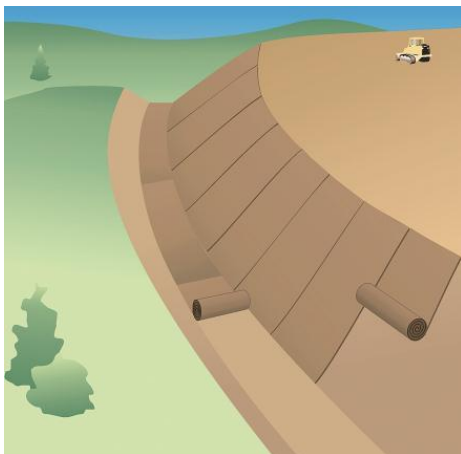

Slopes

Steep, long slopes need blankets. Install blankets up and down long slopes. For channels below slopes, install horizontally. Don't forget to apply seed and fertilizer (if necessary) before installing blankets. Overlap the edges of abutting blankets and anchor the overlap.



Excellent installation of Soil Retention Blankets. Remember to entrench the blanket at the top and bottom of the slope. Staple checks are required every 35 feet.



Poor installation of Soil Retention Blankets. Blankets should have been staked down and overlapped and should fully cover the disturbed area.

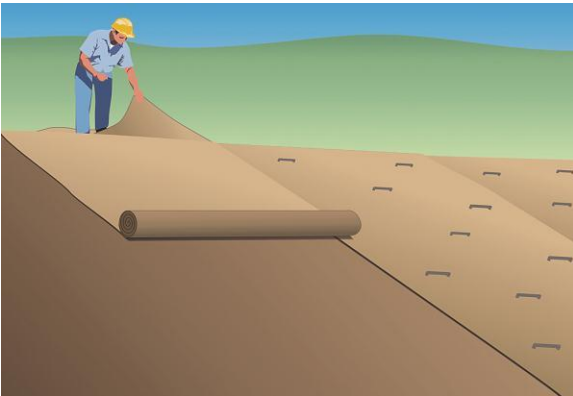

Install blankets vertically on long slopes. Unroll from top of hill, staple as you unroll it. Do not stretch blankets.

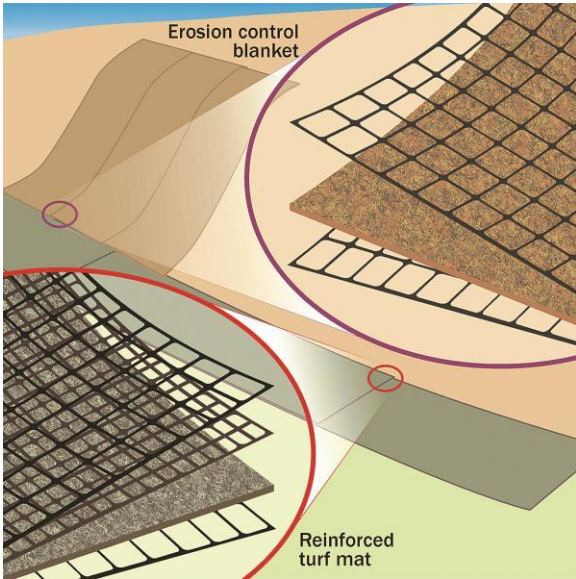

Contact a CDOT Landscape Architect to determine the type of blanket that should be used on the project. Remember to prepare soil, apply topsoil or soil conditioning (if required), and seed prior to placing the blanket.

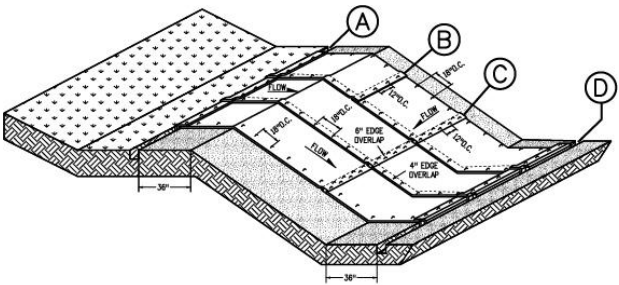

**SOIL RETENTION
BLANKETS/TURF REINFORCEMENT MATS (TRM)
SLOPE APPLICATION**

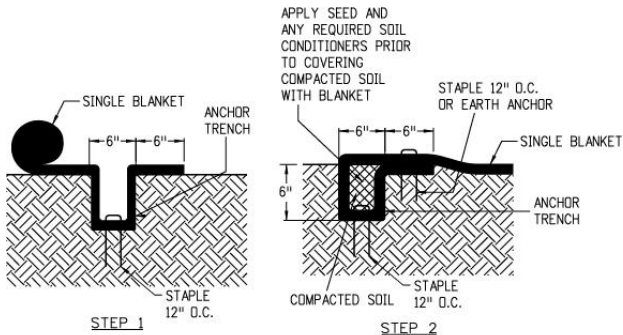

ANCHOR TRENCH (A)

TO BE USED AT THE UPSLOPE AND DOWNSLOPE ENDS OF BLANKET ACROSS THE ENTIRE WIDTH OF SLOPE UNLESS SLOPE RUNS INTO RECEIVING WATER. (SEE DOWNSLOPE END STAPLE CHECK).

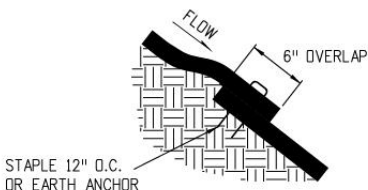

CONSECUTIVE ROLL OVERLAP (B)

TO BE USED WHEREVER ONE ROLL OF BLANKET ENDS AND ANOTHER BEGINS WITH THE UPHILL BLANKET PLACED ON TOP OF THE BLANKET ON THE DOWNHILL SIDE.

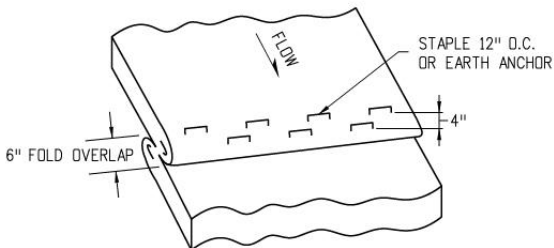

STAPLE CHECK (C)

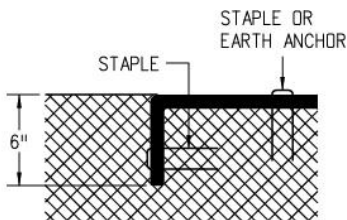

TERMINATION OF CHANNEL ④

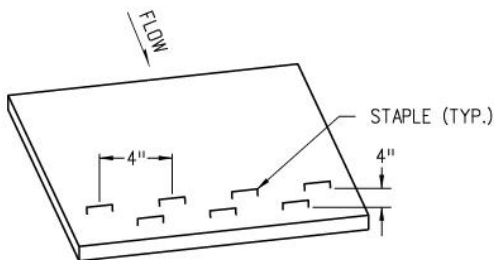

DOWNSLOPE END STAPLE CHECK ④

TO BE USED WHEN SLOPE RUNS INTO A RECEIVING WATER AND CANNOT BE EXTENDED 3 FEET BEYOND SLOPE.

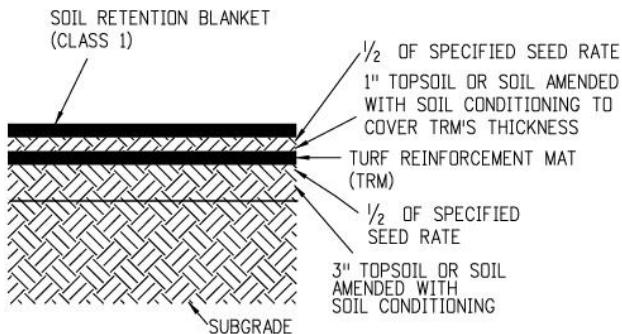

SOIL FILLED TRM APPLICATION

1. PLACE 3" TOPSOIL OR SOIL AMENDED WITH SOIL CONDITIONING.
2. APPLY HALF OF THE SPECIFIED SEED AT THE BROADCAST RATE AND RAKE IT INTO THE SOIL.
3. INSTALL TRM.
4. PLACE 1" TOPSOIL OR SOIL AMENDED WITH SOIL CONDITIONING INTO THE MATRIX TO COVER THE PRODUCT'S THICKNESS.
5. APPLY THE REMAINING HALF OF THE SPECIFIED SEED AT THE BROADCAST RATE AND RAKE IT INTO THE SOIL.
6. INSTALL SOIL RETENTION BLANKET (CLASS 1).

Spray-on Mulch Blankets

Spray-on Mulch Blanket consists of fibers bound together by adhesives. The fibers are colored yellow or green to help the operator insure coverage and apply the material uniformly.

Tips

- Do not add seed to the mixture.
- Apply mixture in an even layer working from side to side, top to bottom.
- Apply at a rate of 3,000 pounds per acre.
- Spray-on Mulch Blanket should not have a cure time.
- Do not apply in ditches or areas of concentrated flows.
- Manufacturing process reduces the potential of introducing seed of undesirable plant species.
- Apply (spray) from multiple angles to prevent shadow areas.



Good example of Spray-On Mulch Blanket. Notice the even coverage across disturbed areas.

Temporary Slope Drain

A Temporary Slope Drain is a flexible conduit for stormwater that extends down the length of a disturbed slope to divert stormwater and serve as a short-term outlet. Embankment protectors convey runoff without causing erosion at the bottom of the slope and are used during grading operations until the permanent drainage structure is installed or final stabilization has occurred on the slope. Temporary Embankment Protectors are often used in conjunction with diversion berms to direct runoff to the slope drain.

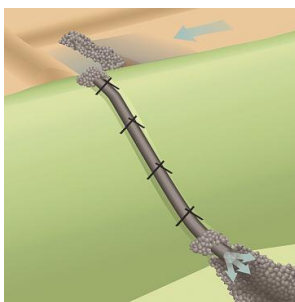

Tips

- Temporary Slope Drains are only for temporary use.
- Use at least 12-inch flexible pipe.
- Securely fasten the pipe together. The pipe must have water-tight fittings and be securely anchored to the slope.
- Direct runoff into pipe using end section or berm.
- Continue pipe beyond toe of slope.
- Erosion control (for example, riprap scour pad or protection) is required at pipe outlet.
- Inspect embankment protectors for erosion and accumulation of debris at the inlet and outlet after each significant rainfall.
- Temporary Slope Drain is conveying sediment-laden water—additional sediment control measures will be required downgradient.

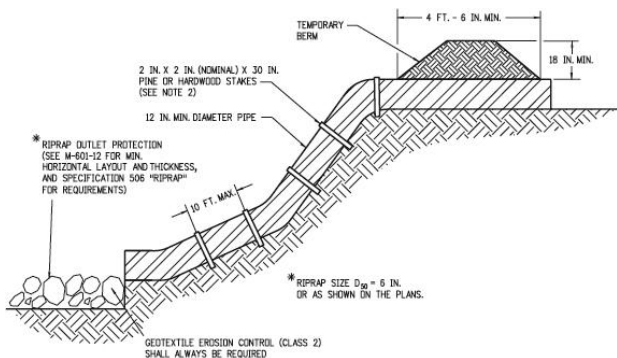

NOTES:

1. ANCHOR SIZE VARIES ACCORDING TO PIPE SIZE
2. TO SECURE THE PIPE, DRIVE STAKES INTO GROUND, THEN TIE A 12 GAUGE WIRE BETWEEN THEM ABOVE AND ACROSS THE PIPE'S WIDTH.
3. THE OUTLET SHALL BE ALIGNED WITH THE FLOW DIRECTION OF THE EXISTING GRADE. PERPENDICULAR DISCHARGE TO A CHANNEL SHALL NOT BE ACCEPTABLE.
4. THE GRADE AROUND THE INLET TO THE PIPE SHALL BE COMPACTED.

TEMPORARY SLOPE DRAINS



Notice how slope is stabilized, pipe is properly staked, and riprap protection is installed around the outlet.



Notice how the slope has eroded. This is an example of an appropriate place for an embankment protector.



This page intentionally left blank.

Chapter 4 **Ditches**

Ditches	4-2
Check Dam.....	4-2
Soil Retention Blankets (SRB) and Turf Reinforcement Mats (TRM) for Ditch Use.....	4-9

Ditches

Drainage ditches need Check Dams to reduce the speed of water and capture sediment. Soil Retention Blankets and Turf Reinforcement Mats can also be used in ditches to reduce the speed of water and prevent ditch erosion. Remove temporary Check Dams after the site has been stabilized and vegetated.

Check Dam

Check Dams are relatively small structures constructed across a ditch. As stormwater runoff flows through the structure, the Check Dam catches sediment from the channel itself or from the contributing drainage area. Check Dams are typically constructed out of erosion logs, rock, silt dikes, or silt berms. They are most effective when used with other stormwater, erosion, and sediment-control measures. Temporary Check Dams should be removed when their useful life has been completed. In the case of grass-lined ditches, Check Dams should be removed when the grass has matured sufficiently to protect the ditch or swale from erosion. The area beneath the Check Dams should be seeded and mulched immediately after the Check Dams are removed.

Sediment should be removed and properly disposed of when it has accumulated to half of the original height of the Check Dam. Inspect for erosion along the ends of the Check Dams and repair immediately when necessary.

Erosion Log Check Dam

Tips

- Embed Erosion Log 2 inches into soil and ensure contact with the ground for its entire length.
- Place Erosion Logs on top of Soil Retention Blankets to help reduce water velocity.
- Proper staking is essential for Erosion Log function.
- Diameter of the Erosion Log is specified in the SWMP.



Notice how the Erosion Log is embedded 2 inches deep into the soil and keyed into the side slope.



Notice how the Erosion Log is not keyed into the side slope.

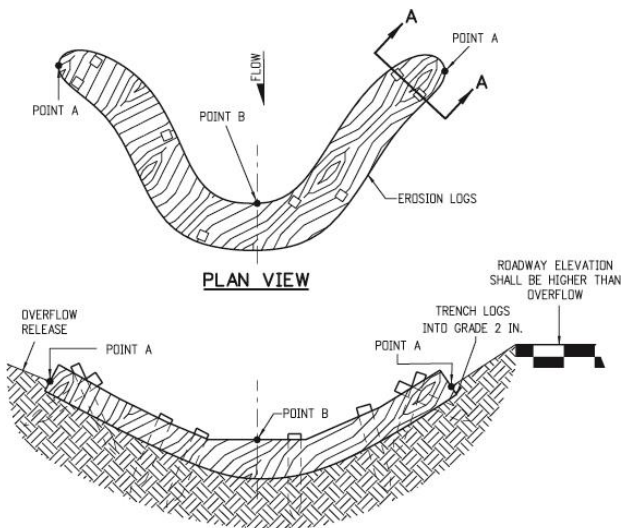

NOTE: POINTS "A" SHALL BE A MINIMUM 4 IN. HIGHER THAN POINT "B".

ELEVATION

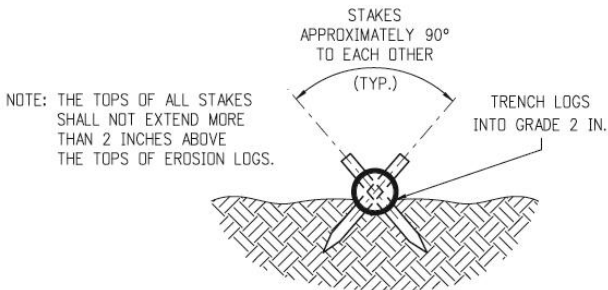

SECTION A-A

NOTES:

1. EROSION LOGS SHALL BE EMBEDDED 2 INCHES INTO THE SOIL.
2. EROSION LOGS SHALL BE TIGHTLY ABUTTED WITH NO GAPS.
3. V-SHAPED TEMPORARY DITCHES SHALL NOT BE USED. DITCHES SHALL BE GRADED IN A PARABOLIC OR TRAPEZOIDAL SHAPE.

EROSION LOG INSTALLATION

Temporary Rock Check Dam

Tips

- A 2-year-or-larger storm should safely flow over the Check Dam without an increase in upstream flooding or destruction of the Check Dam.
- The height of the Check Dam at the center should be 2 feet, and the Check Dam should be wide enough to reach from bank to bank of the ditch or swale. Geotextile fabric below the rock is essential for proper function. Riprap size is detailed in the design. If riprap size is not part of the design, contact a CDOT Hydraulic Engineer.
- Construct the Check Dam with a low point or controlled release point (weir elevation).
- Key the Check Dam into side slopes of ditch.
- As a general rule, the maximum spacing between dams should be such that the toe of the upstream Check Dam is at the same elevation as the controlled release point (weir elevation) of the downstream dam.
- Do not install Check Dams in live streams.



Excellent installation of rock Check Dams.

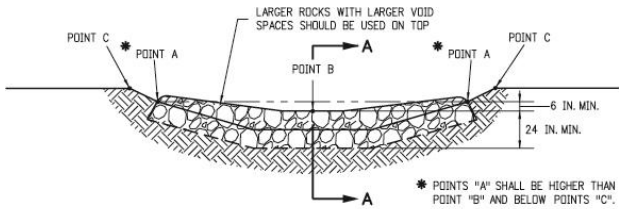

TYPICAL SECTION VIEW

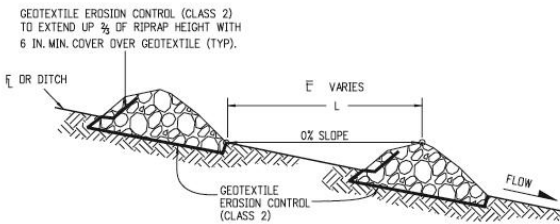

SECTION VIEW ALONG DITCH FLOWLINE

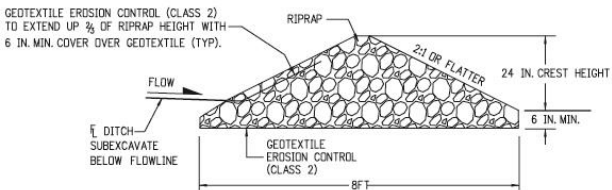

SECTION A-A

NOTES:

1. RIPRAP SIZE $D_{50} = 6$ IN OR AS SHOWN ON THE PLANS.
2. THE ENDS OF RIPRAP CHECK DAM SHALL BE A MINIMUM OF 6 IN. HIGHER THAN CENTER OF CHECK DAM.
3. FOR USE AS TEMPORARY CHECK DAMS ONLY AND NOT FOR PERMANENT INSTALLATIONS.

ROCK CHECK DAM

Silt Dike Check Dam



An excellent installation of a silt dike Check Dam.



Poor installation and maintenance of a silt berm Check Dam.

Accumulated sediment should be removed, and the right side of the dike should be extended up the slope.



Silt Berm Check Dam



Excellent installation of a silt berm Check Dam.



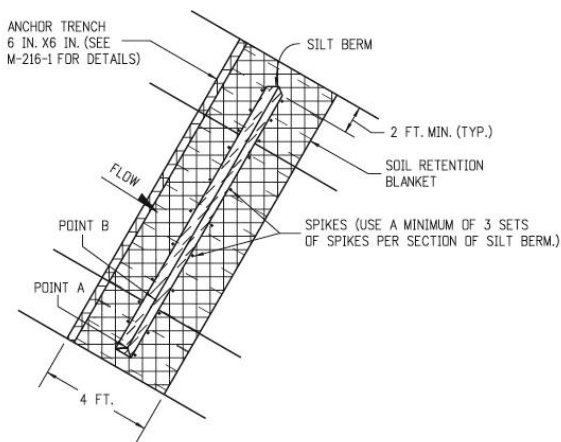

PLAN VIEW

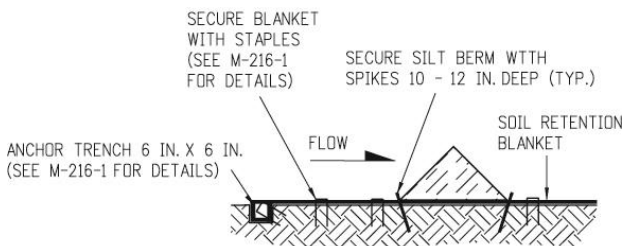

SILT BERM (1) SECTION VIEW

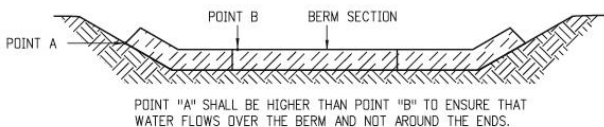

FRONT VIEW

NOTES

1. ANCHOR SOIL RETENTION BLANKET INTO TRENCH WITH 8 INCHES MIN. STAPLES PLACED AT 1 FOOT INTERVALS ALONG EDGE.
2. FILL AND COMPACT TRENCH.
3. SECTIONS OF THE SILT BERM SHALL BE OVERLAPPED WITH NO GAPS.
4. FOR SLOPE AND CHANNEL SPACING SEE THE "SECTION VIEW ALONG DITCH FLOWLINE" DETAIL ON SHEET 11 OF 11.
5. SOIL RETENTION BLANKET SHALL ALWAYS BE REQUIRED.

SILT BERM INSTALLATION

Soil Retention Blankets (SRB) and Turf Reinforcement Mats (TRM) for Ditch Use

Drainage ditches convey stormwater runoff through a stable conduit. Vegetation lining the ditch slows concentrated runoff. Because grassed channels are not usually designed to control peak runoff loads by themselves, they are often used with additional control measures, such as Check Dams. If the drainage ditch is over 2 percent grade, contact a CDOT Landscape Architect for recommendations on blanket type. The following application table may be used as guidance.

	Product Class	Tensile Strength MD ASTM D 6818	Maximum Permissible Shear Stress (Unvegetated SRB, Unvegetated TRM) ASTM D 6460	Ditch Gradient Slope %
SRB	1 ^a	100 lbs/ft		> 0 to 2
	2 ^a	125 lbs/ft		
TRM	1 ^b	125 lbs/ft	1.8 lbs/ft ²	> 2 to 3
	2 ^b	150 lbs/ft	2.5 lbs/ft ²	> 3 to 4
	3 ^b	175 lbs/ft	3.1 lbs/ft ²	> 4 to 5
		Soil-loaded Embedded Riprap	Contact Region Hydraulic Engineer	> 5

^a SRB shall be approved photodegradable or biodegradable blanket.

^b All TRM Classes shall be soil-loaded with SRB Class 1 or Class 2 (70 percent straw-30 percent coconut, excelsior, or 100 percent coconut fiber) installed as final cover.

Tips

- Lay in blankets similar to roof shingles; start at the lowest part of the ditch, then work your way up. Uphill pieces lap over downhill sections. Staple through both layers around edges at the overlap. Trench, tuck, and tamp down ends at the top of the slope. Do not stretch blankets or mats.
- Avoid creating V-shaped ditches. Construct U- or trapezoidal-shaped ditches.

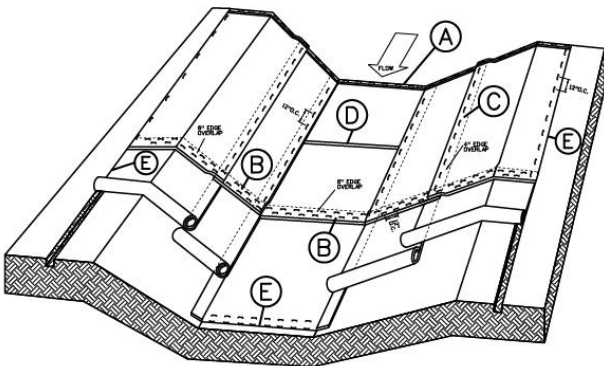

SOIL RETENTION BLANKETS/TURF REINFORCEMENT MATS (TRM) CHANNEL APPLICATION

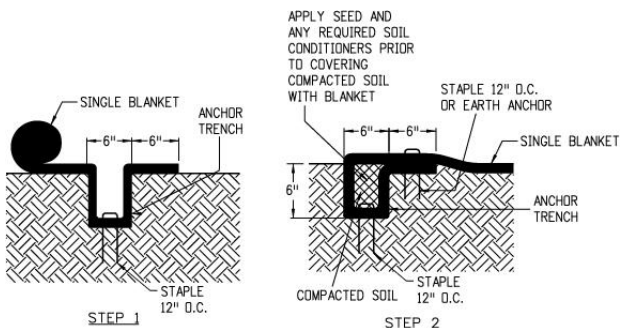

ANCHOR TRENCH (A)

TO BE USED AT THE UPSLOPE AND DOWNSLOPE ENDS OF BLANKET ACROSS THE ENTIRE WIDTH OF SLOPE UNLESS SLOPE RUNS INTO RECEIVING WATER. (SEE DOWNSLOPE END STAPLE CHECK).

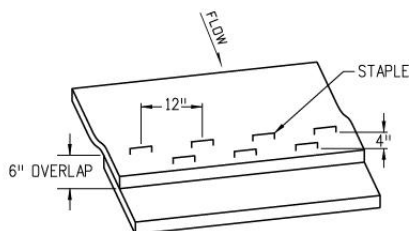

CONSECUTIVE ROLL OVERLAP (B)

NOTES

1. Z SHAPED FOLD TO BE USED ON SLOPE EVERY 35 FEET MAXIMUM.
2. STAPLE CHECK LOCATIONS SHOULD BE AT LEAST 15 FEET FROM THE BOTTOM OF SLOPE.
3. TO BE USED WHEREVER ONE ROLL OF BLANKET ENDS AND ANOTHER BEGINS WITH UPSTREAM BLANKET PLACED ON TOP OF THE BLANKET ON THE DOWNSTREAM SIDE.

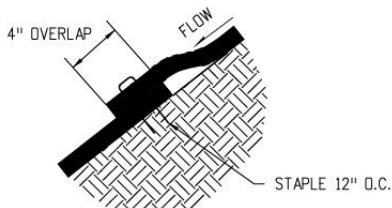

SIDE SEAM OVERLAP (C)

TO BE USED FOR OVERLAP WHEN 2 WIDTHS OF BLANKET ARE APPLIED SIDE BY SIDE WITH THE UPHILL BLANKET PLACED ON TOP OF THE BLANKET ON THE DOWNHILL SIDE.

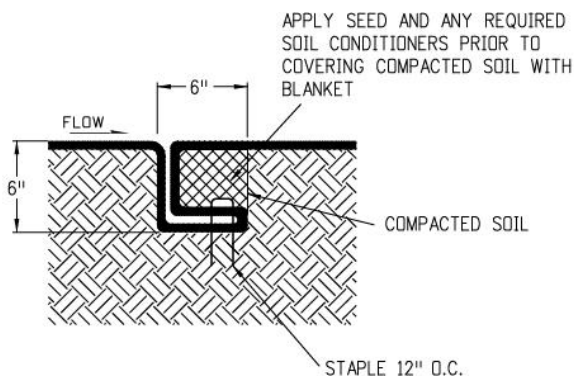

CHANNEL CHECK SLOT (D)

TO BE USED AT 30' INTERVALS IN CHANNEL FLOWLINE.

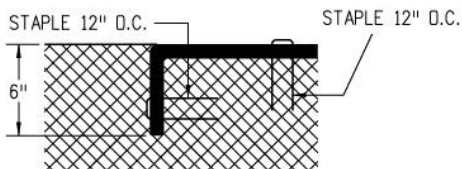

TERMINATION OF CHANNEL (E)

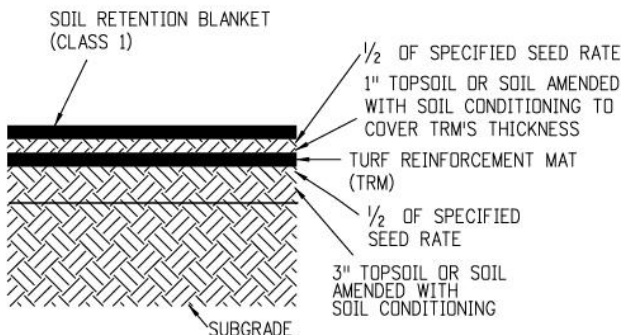

SOIL FILLED TRM APPLICATION

1. PLACE 3" TOPSOIL OR SOIL AMENDED WITH SOIL CONDITIONING.
2. APPLY HALF OF THE SPECIFIED SEED AT THE BROADCAST RATE AND RAKE IT INTO THE SOIL.
3. INSTALL TRM.
4. PLACE 1" TOPSOIL OR SOIL AMENDED WITH SOIL CONDITIONING INTO THE MATRIX TO COVER THE PRODUCT'S THICKNESS.
5. APPLY THE REMAINING HALF OF THE SPECIFIED SEED AT THE BROADCAST RATE AND RAKE IT INTO THE SOIL.
6. INSTALL SOIL RETENTION BLANKET (CLASS 1).

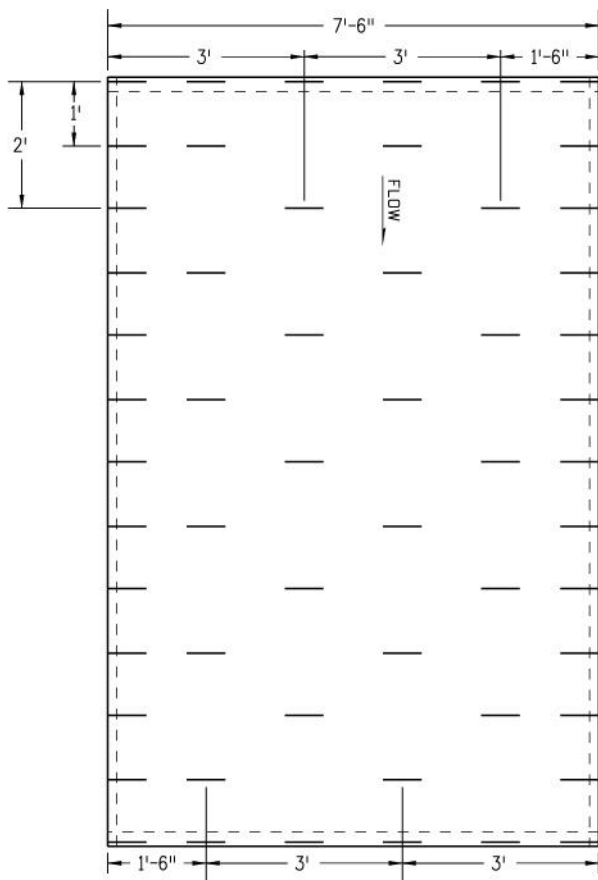

TYPICAL STAPLE PATTERN
FOR CHANNEL APPLICATION

This page intentionally left blank.

Chapter 5 Inlet/Outlet Protection

Inlet and Outlet Protection	5-2
Inlet Protection.....	5-2
Outlet Protection	5-8

Inlet and Outlet Protection

Culverts and ditches are designed to carry moderate to large amounts of stormwater. They also can carry a lot of sediment to streams, rivers, wetlands, lakes, and sensitive areas if they are not properly protected. Culvert and swale outlets can become severely eroded if fast stormwater flows are not controlled.

Inlet Protection

Storm drain Inlet Protection measures prevent sediment and debris from entering storm drain inlets. Inlet Protection is implemented at existing inlets prior to construction, but new inlets are protected as they are installed and brought online. Inlets can be protected with Erosion Logs, Erosion Bales, or other sediment control devices. Place Inlet Protection prior to milling operations or other activities when debris may enter storm drain inlets.

Erosion Logs

Tips

- Place logs around the top of inlets to prevent sediment from falling in the flow line from above.



Bad installation of Erosion Logs. Stormwater is bypassing the Erosion Log.



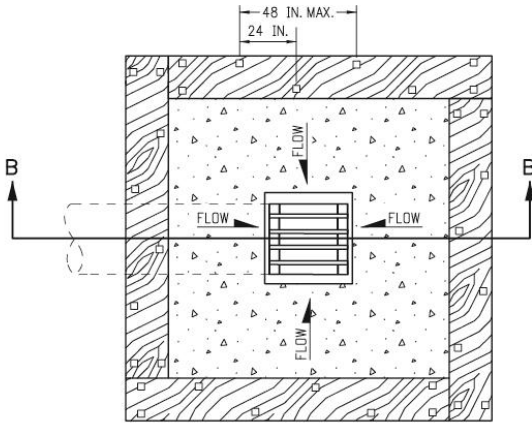

PLAN VIEW

NOTE: THE TOPS OF ALL STAKES SHALL NOT EXTEND MORE THAN 2 INCHES ABOVE THE TOPS OF EROSION LOGS.

TRENCH LOGS INTO GRADE 2 IN. (TYP.)

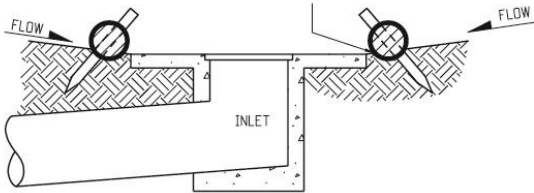

SECTION B-B

NOTE: LOCATE EROSION LOGS AT THE OUTSIDE EDGE OF THE CONCRETE APRON.

EROSION LOG FILTER AT DROP INLET

Erosion Bales

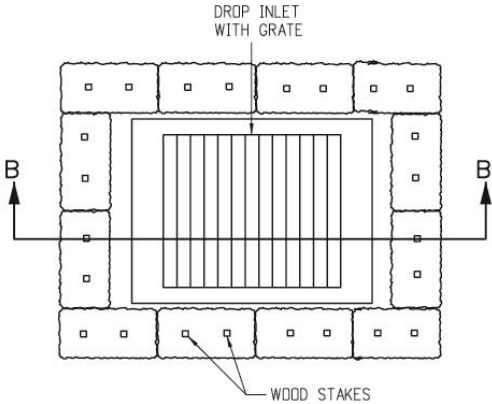

PLAN VIEW

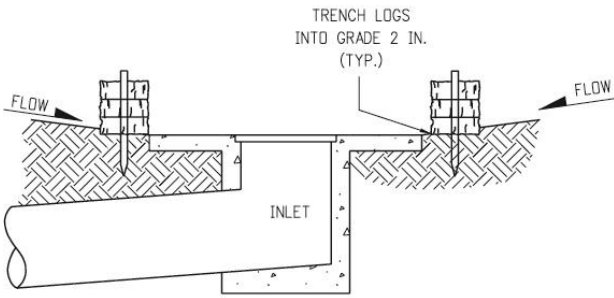

SECTION B-B

NOTE: LOCATE EROSION BALES AT THE OUTSIDE EDGE OF THE CONCRETE APRON.

EROSION LOG FILTER AT DROP INLET

NOTES

1. STAKES SHALL BE WOOD AND SHALL BE 2 IN. X 2 IN. X 30 IN. NOMINAL.
2. EROSION BALES SHALL BE 18 IN. X 18 IN. X 36 IN.
3. EROSION BALES SHALL BE ENTRENCHED 4 IN. MINIMUM INTO THE SOIL, THIGHTLY ABUTTED WITH NO GAPS, STAKED, AND BACKFILLED AROUND THE ENTIRE OUTSIDE PERIMETER.
4. EROSION BALES CANNOT BE USED FOR CHECK DAMS.
5. EROSION BALE FILTER SHALL BE LOWER THAN BERM ELEVATION OR USED IN A SUMP CONDITION.
6. THE PAY ITEM NUMBER FOR EROSION BALES (WEED FREE) (EA) IS 208-00011.

Inlet/Outlet Protection



Good installation of Inlet Protection with Silt Fence and Erosion Bales. Use Erosion Bales only if the area adjacent to the inlet consists of soil.

Inlet Storm Protection

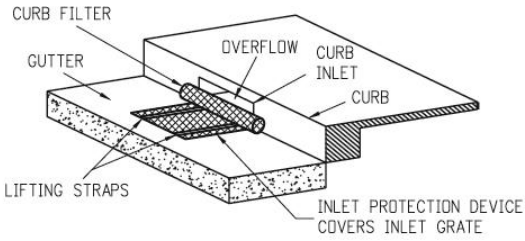

ISOMETRIC VIEW

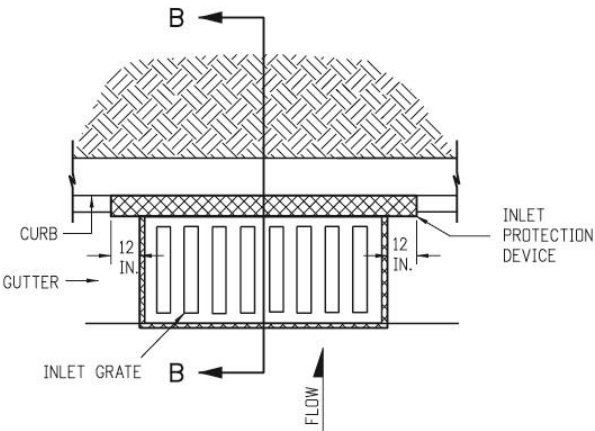

PLAN VIEW

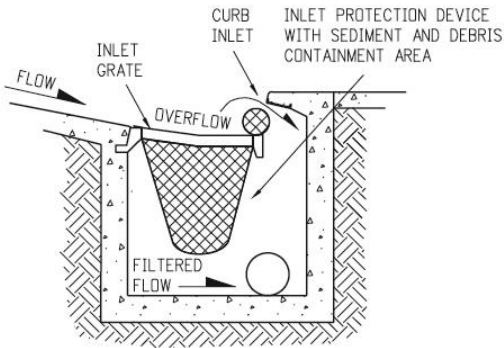

SECTION B-B

STORM DRAIN INLET PROTECTION (TYPE II)

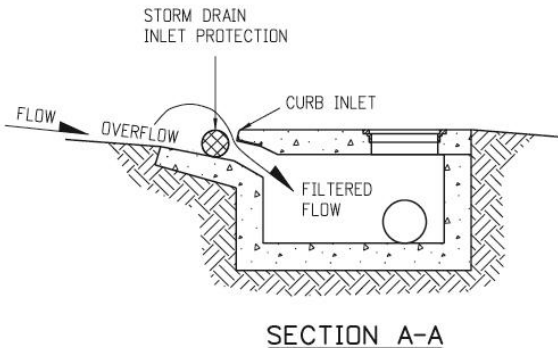
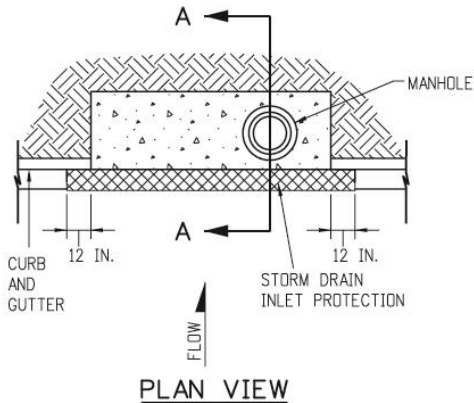

NOTES:

1. INLET PROTECTION DEVICE SHALL EXTEND 12 INCHES PAST EACH END OF THE INLET.
2. FOR STORM DRAIN INLET TYPES I AND II, IF THERE IS A MINIMUM CLEARANCE OF 3 FEET FROM THE EDGE OF THE TRAVELED WAY TO THE FACE OF CURB, USE THE AGGREGATE BAGS AT STORM DRAIN INLET (TYPE I) DETAIL ON SHEET 4 INSTEAD.

STORM DRAIN INLET PROTECTION (TYPE I)



Poor inlet protection. The sock does not extend 1 foot past each end of the inlet.





Outlet Protection

Outlet Protection prevents scour and erosion at the outlet of a channel or conduit by reducing the speed of stormwater. Outlet Protection comprises geotextile fabric and riprap placed at the outlet.

Inlet/Outlet
Protection

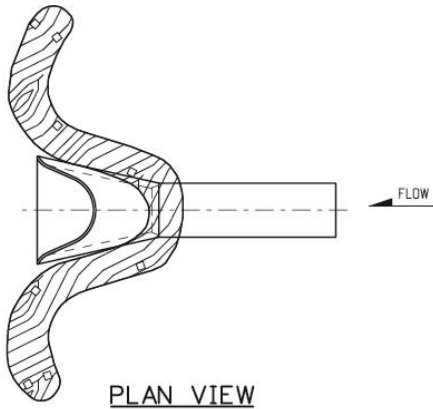

PLAN VIEW

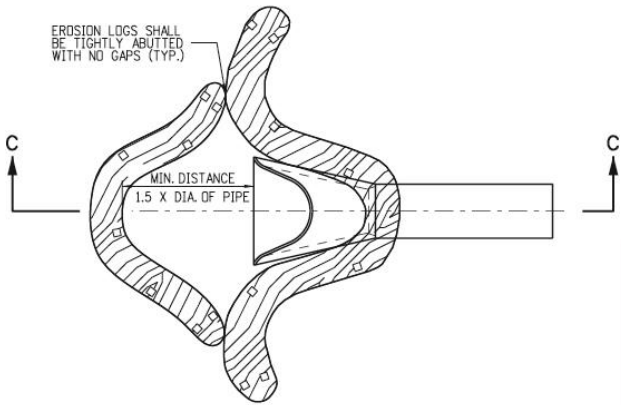

PLAN VIEW

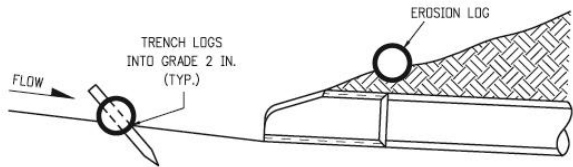

SECTION C-C

NOTE: TOP OF STAKE SHALL NOT EXTEND PAST TOP OF EROSION LOG MORE THAN 2 IN.

EROSION LOG CULVERT INLET PROTECTION



Good use of erosion logs as Outlet Protection. The Erosion Log above the culvert helps prevent debris and dirt from falling into the outlet. The two rows of logs in front of the culvert prevent sediment from flowing downstream.



Poor installation of Outlet Protection. Geotextile was not placed under the riprap and not enough rock was used. As a result, stormwater is undercutting the existing rock.

Chapter 6 **Sediment Traps**

Temporary Sediment Traps.....	6-2
-------------------------------	-----

Temporary Sediment Traps

Sediment Traps are small impoundments that allow sediment to settle out of stormwater runoff.

Sediment Traps are usually used for areas draining 5 acres or less. Traps should not be located closer than 20 feet from a proposed building foundation or highway alignment.

A permanent detention pond can be used as a Temporary Sediment Trap if:

- It is marked on the SWMP as a temporary control measure.
- The pond is inspected and maintained in accordance with the Stormwater Construction Permit.
- The pond is designed and implemented in accordance with good engineering, hydraulic, and pollution control practices; it includes an outlet that discharges water withdrawn from or near the surface, unless infeasible.
- Outlets that withdraw water from or near the surface shall be installed when discharging from basins and impoundments, unless infeasible.

Tips

- Install Temporary Sediment Traps before any land disturbance takes place in the drainage area.
- Remove sediment from the Trap when the wet storage volume has been reduced by half.
- Underly the outlet of a Trap with geotextile fabric; the outlet should be at least 1 foot high.
- The slope on the outlet shall be no steeper than 2:1.
- Use riprap $D_{50} = 12$ inch for Sediment Trap outlets.

- Dig down Sediment Traps only to a maximum of 4 feet, do not install in live streams, and do not mix with groundwater.



Sediment Traps often have pipe risers, but well-constructed rock overflow outlet notches in the dam or retaining berm are acceptable if the overflow area is protected from erosion.

Float Skimmers

Float Skimmers rest on the surface of the pond and pump water out of the pond. The Skimmer allows sediment to settle to the bottom of the pond while drawing clean runoff from the surface. They work best for catchment basins collecting 0.75 acre or less.

Tips

- Ensure the basin length to width ratio is 2:1.
- Use baffles to prevent damage caused from large debris.
- Provide erosion protection for all Skimmer outfalls.

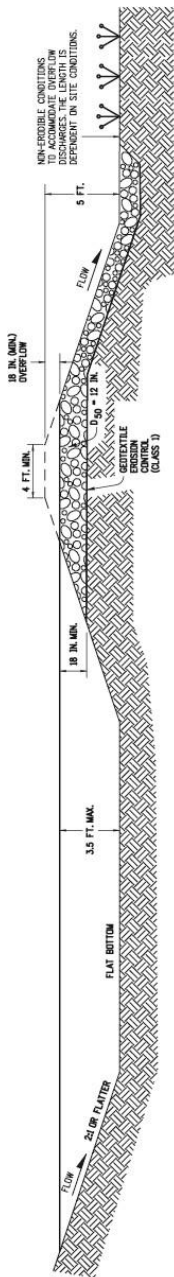

SECTION A-A

NOTES

1. THE MAXIMUM DRAINAGE AREA IS 5 ACRES.
2. THE MAXIMUM STRUCTURE LIFE IS 2 YEARS.
3. THE STORAGE AREA IS 1800 CUBIC FEET PER ACRE.
4. THE MAXIMUM EMBANKMENT HEIGHT SHALL BE 5 FT. MEASURED ON THE DOWNSTREAM SIDE.
5. THE LENGTH/WIDTH RATIO MAY BE ADJUSTED TO MEET SITE CONDITIONS WHEN APPROVED BY THE ENGINEER.
6. WIDTH (W) OF SEDIMENT TRAP IS APPROXIMATELY EQUAL TO THE WEIR LENGTH (X).
7. SEDIMENT TRAP DESIGN SHALL BE APPROVED BY THE ENGINEER.
8. THE DOWN GRADE FROM WEIR SHALL BE STABLE AND NON-ERODIBLE.

SEDIMENT TRAP

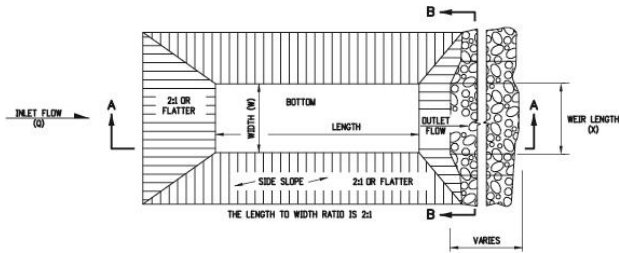

PLAN VIEW

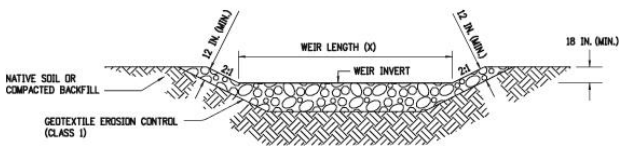

SECTION B-B

DRAINAGE AREA (ACRES)	WEIR LENGTH (FEET)
1	4
2	6
3	8
4	10
5	12

WEIR LENGTH TABLE

SEDIMENT TRAP

Temporary use of Extended Detention Basins
 Extended Basins shown in the construction plans may be used as temporary control measures if:

- Written approval agreements are collected from both the Owner and entity maintaining the Detention Basin to incorporate the structure as a control measure on the SWMP (including CDOT Maintenance, if relevant).

- A written maintenance agreement for the Detention Basin during the period of construction up to final acceptance of the construction project is signed by the Contractor, Owner, and the entity responsible for maintenance of the Detention Basin.
- The Detention Basin is designated as a construction control measure in the SWMP.
- The Detention Basin is protected with Erosion Bales, Erosion Logs, and/or Silt Fence.
- The Detention Basin is designed and implemented for use as a control measure during construction in accordance with good engineering, hydrologic, and pollution control practices.
- The Detention Basin is inspected and maintained.
- All silt and debris are removed, and the Detention Basin is returned to the design grade and contour prior to project acceptance.
- Upon project completion, sediment removal from the facility and repairs is inspected by the Owner and original maintenance entity. Written acceptance by all parties must be obtained as part of the substantial and final acceptance of the project.

Chapter 7 **Pollution Prevention**

Pollution Prevention	7-2
Concrete Washout Structure	7-2
Construction Site Liquid and Solid Waste Management.....	7-6
Spill Prevention and Control	7-8
Stockpile Management	7-12
Sweet Sweeping and Vacuuming	7-14

Pollution Prevention

Concrete Washout Structure

Concrete Washout Structures are used to contain uncured concrete and concrete wastewater when the chutes of concrete mixers and hoppers of concrete pumps are rinsed out after delivery. The washout facilities can be constructed or prefabricated (pre-approved manufactured products can be found on CDOT Approved Products List). All washout facilities consolidate solids for easier disposal and to prevent runoff of concrete waste water.

The wash water is alkaline and contains high levels of chromium, which can leach into the ground and contaminate groundwater. It can also migrate to a storm drain, which can increase the pH of nearby waterways and harm aquatic life.

Tips

- Clean out facilities once they are two-thirds full or construct new facilities to provide additional concrete waste storage.
- Adding solvents, flocculants, or acid to washwater is prohibited.
- Locate the washout no less than 50 feet horizontally away from State Waters.
- Do not place concrete washouts in low areas or ditches.
- Permanent disposal of concrete washout waste on the construction site is prohibited.

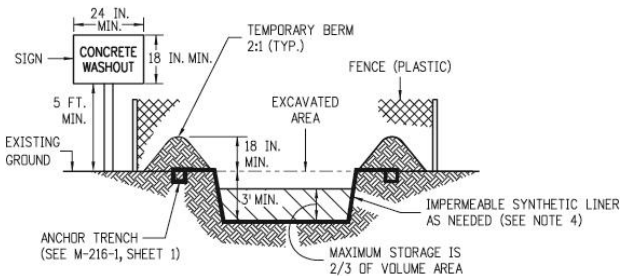
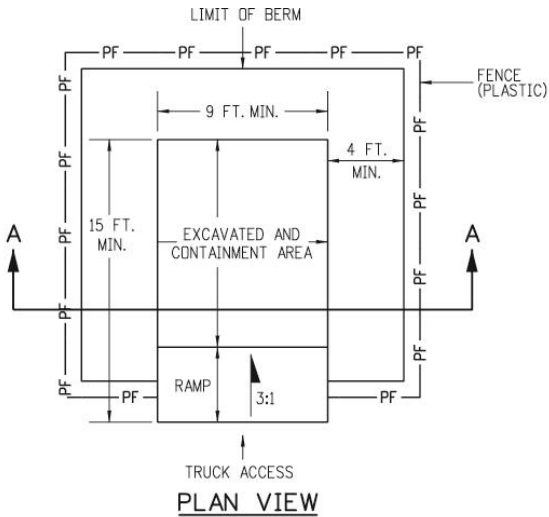

NOTES:

1. A FENCE (PLASTIC) SHALL BE INSTALLED AROUND THE CONCRETE WASHOUT AREA, EXCEPT AT THE OPENING.
2. THE CONCRETE WASHOUT SIGN SHALL HAVE LETTERS AT LEAST 3 INCHES HIGH.
3. ALL MATERIALS AND LABOR TO COMPLETE THE CONCRETE WASHOUT STRUCTURE SHALL BE INCLUDED IN THE COST OF WORK AND NOT PAID FOR SEPARATELY.
4. THE BOTTOM OF EXCAVATION SHALL BE A MINIMUM OF FIVE FEET ABOVE GROUND WATER.

CONCRETE WASHOUT STRUCTURE



Place concrete waste in a temporary concrete washout facility located a minimum of 50 feet from State Waters, drainageways, and inlets.

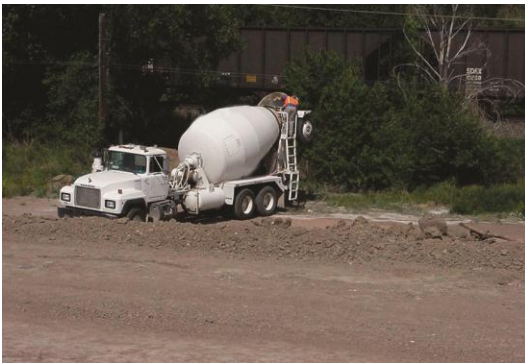

Concrete wash water is alkaline and contains high levels of chromium, which can leach into the ground and contaminate groundwater. It can also migrate to a storm drain, which can increase the pH of area waters and harm aquatic life.

Dispose of concrete washout only in a properly labeled concrete washout facility.



Excellent installation of a prefabricated (aboveground) concrete washout structure.

Construction Site Liquid and Solid Waste Management

Building materials and other construction site wastes, including sanitary wastes, must be properly managed and disposed of to reduce the potential from pollution.

Practices such as trash disposal, recycling, proper maintenance of sanitary facilities, and spill prevention and cleanup measures can reduce the potential for stormwater runoff to mobilize construction site wastes and contaminate surface or groundwater.



Poor placement of a temporary sanitary facility. Temporary sanitary facilities should be located 50 feet horizontally away from State Waters, drainageways, inlets, receiving waters, areas of high traffic, and areas susceptible to flooding. Do not allow wastewater generated from sanitary facilities to flow into storm sewers and drainageways. Only authorized licensed haulers may dispose of waste. Secure facilities to prevent overturning in areas susceptible to strong winds.



Segregate waste properly into various categories such as hazardous materials, toxic liquids, nonhazardous materials, and recyclable materials. Proper disposal is required for each byproduct category.



Containers of liquids should have secondary containment and be stored away from drainageways, inlets, receiving waters, areas of high traffic, and areas susceptible to flooding. Containers also should be properly labeled.



Poor placement of containers of liquid. The secondary containment control measure should hold 110 percent of the volume of the largest container.



Spill Prevention and Control

The Spill Response Plan shall clearly state measures to stop the source of a spill, contain the spill, clean up the spill, dispose of contaminated materials, and train personnel to prevent and control future spills. Spill Response Plans are applicable to construction sites where hazardous wastes are stored or used. Hazardous wastes include pesticides, paints, cleaners, petroleum products, concrete curing and admixtures, fertilizers, and solvents.

Tips

- Personal safety is the primary importance.
- Know the location of the spill response plan along with the name and contact information for the Spill Response Coordinator.
- Contain and clean up spills immediately upon discovery.
- If complete cleanup is not possible immediately, then contain spills until cleanup methods can be employed.
- Store spill kits where potential pollutants are located. Several kits may be needed if there are multiple storage areas. Follow manufacturer's methods for cleanup and proper disposal.
- Follow proper spill and illicit discharge reporting procedures for both hazardous and nonhazardous materials.
- Do not wash down spills into the storm drain or bury them anywhere.

Cleanup Response Procedures

For **nonhazardous materials** such as gasoline, paint, or oil that may be spilled in **small quantities**, implement the following measures:

- **Personal safety is the primary importance.**
- Use absorbent materials to contain spills and clean the area of residuals.
- Dispose of the absorbent material, soil, and/or rotomill properly.
- Do not hose down spill area with water.

For **nonhazardous materials** that qualify as a **significant spill**, implement the following measures:

- Contact CDPHE 24-hour Environmental Emergency Spill Reporting Line (1-877-518-5608) within 24 hours of the spill event. A written notification to CDPHE is necessary within 5 days.
- Contact the Colorado State Patrol 24-hour hotline (303-239-4501) if the spill is on a state highway.
- Report spill to PE and CDOT maintenance personnel on patrol.
- Call the CDOT illicit discharge hotline (303-512-4426) if spilled material spreads to CDOT storm drain or waterway adjacent to CDOT right-of-way.
- Clean up spills immediately. Use absorbent materials if the spill is on an impermeable surface. Construct a slightly compacted earth dike to contain a spill on dirt areas. If rainfall is present at the time of the spill, cover the spill with a tarp to prevent contaminating runoff.

For spills involving **hazardous materials**, implement the following measures:

- **Personal safety is the primary importance. Stay upwind and at a safe distance; secure the area from anyone being harmed.**
- Contact the local emergency response team by dialing 911.
- Contact CDPHE 24-hour Environmental Emergency Spill Reporting Line (1-877-518-5608) within 24 hours of the spill event. A written notification to CDPHE is necessary within 5 days.
- Contact the Colorado State Patrol 24-hour hotline (303-239-4501) if the spill is on a state highway.
- Report spills to the PE and CDOT maintenance personnel on patrol.
- Call the CDOT illicit discharge hotline (303-512- 4426) if spilled material spreads to CDOT storm drain or waterway adjacent to CDOT right-of-way.
- Use a licensed contractor or a HazMat team to properly clean up spills immediately.
- Do not use construction personnel to clean up the spill.



All spills should be cleaned up immediately.





Inspect equipment and vehicles routinely for leaks. Maintain an ample supply of cleanup materials at all designated maintenance areas where leaks and spills are likely to occur.



Inspect fueling locations routinely for leaks. Maintain an ample supply of cleanup materials at all designated maintenance areas where leaks and spills are likely to occur.

Stockpile Management

Stockpiles of soil and other erodible materials must be managed so that stormwater does not come in contact with the pile and potentially wash pollutants into State Waters, including wetlands.

Tips

- Spray topsoil/embankment stockpiles, where work is temporarily halted, with Mulch/Mulch Tackifier to prevent wind erosion.
- Always contain the erodible stockpiles with a control measure at the toe (or within 20 feet of the toe).
- Do not place stockpiles in drainageways or within 50 feet of State Waters.



Note that tarps are being used to cover unused materials and materials are on pallets.



There are no temporary perimeter sediment barriers such as Erosion Logs, Silt Fence, or Compacted Berms to protect this stockpile from stormwater runoff.

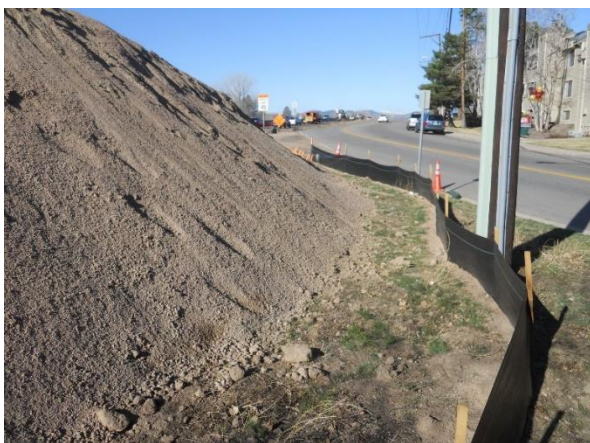

Notice the space between the soil stockpile and the control measure for sediment collection and access for maintenance.

Street Sweeping and Vacuuming

The construction of streets, roads, highways, and parking lots can cause the accumulation of significant amounts of pollutants that can potentially contribute to stormwater pollutant runoff to surface waters. Pollutants, including sediment, debris, and trash, can be minimized by street sweeping.

Tips

- Inspect potential sediment tracking locations daily and sweep or vacuum as necessary.
- Dispose of all sweepings properly.
- Be careful not to sweep up any unknown substance or objects that may be potentially hazardous.
- Do not use kick brooms or sweeper attachments.



Excellent use of a sweeper to clean up a construction site.

Chapter 8 **Special Conditions**

Dewatering Structure 8-2

Steam Crossing 8-3

Dewatering Structure

Dewatering structures settle and filter sediment-laden water (see the Sediment Trap control measure Chapter 6). **Dewatering requires compliance with Sections 107.25.b.7 and 107.25.b.8 of the latest CDOT Standard Specifications for Road and Bridge Construction document, which can be found at:**

<https://www.codot.gov/business/designsupport>

Tips

- Do not directly discharge water from dewatering operations directly into any State Waters (including wetlands, irrigation ditches, canals, or storm sewers) unless allowed by the permit.
- Discharge into sanitary sewers will not be allowed unless written permission is obtained from the municipality or owner of the sanitary sewer system.
- Place dewatering bags on level ground that has been stabilized with blanket, rock, or another approved control measure.



Good use of dewatering bag – notice it is outside of State Waters and uses Erosion Logs as a secondary control measure.

Steam Crossing

A temporary steam crossing is used to provide a way for construction vehicle traffic to cross a watercourse. Temporary access crossings are not intended to be used for general public traffic. Section 404 permitting (401 Certification) may be required. **The design of temporary stream crossings must be designed and stamped by a Professional Engineer.**

A bridge or culvert is the best choice for most temporary stream crossings. The materials used to construct most bridges and culverts can be salvaged after they are removed.

Tips

- Place the temporary waterway crossing at right angles to the stream or as directed by PE.
- All crossings shall have one traffic lane. The minimum width shall be 12 feet with a maximum width of 20 feet.
- Remove all temporary crossings within 14 calendar days after the structure is no longer needed.

Maintenance

- Inspect weekly and after each significant rainfall. Include assessment of foundations during inspection.
- Periodically remove silt from crossings.
- Replace riprap along inlets and outlets of culverts.



Good application of temporary culvert. Notice riprap approach to culvert.



No riprap at approach to prevent sediment from entering the stream.



Good use of temporary bridge.



Environmental Ethics Statement

CDOT will support and enhance efforts to protect the environment and quality of life for all of Colorado's citizens in the pursuit of providing the best transportation systems and services possible.

CDOT's Environmental Stewardship Guide, November 2017

<https://www.codot.gov/programs/environmental/resources/guidance-standards/cdot-environmental-stewardship-guide-nov-2017/view>



COLORADO
Department of Transportation