

Report No. CDOH-DTD-R-90-13

IN-SERVICE EVALUATION OF HIGHWAY SAFETY DEVICES EXPERIMENTAL PROJECT NO. 7

James A. Mohamed-Ali
Colorado Department of Highways
4201 East Arkansas Avenue
Denver, Colorado 80222

Construction Report
November 1990

Prepared in cooperation with the
U.S. Department of Transportation
Federal Highway Administration

The contents of this report reflect the views of the author who is responsible for the facts and the accuracy of the data presented herein. The contents do not necessarily reflect the official views of the Colorado Department of Highways or the Federal Highway Administration. This report does not constitute a standard, specification, or regulation.

1. Report No. CDOH-DTD-R-90-13		2. Government Accession No.		3. Recipient's Catalog No.	
4. Title and Subtitle In-Service Evaluation of Highway Safety Devices Experimental Project No. 7				5. Report Date November 1990	
				6. Performing Organization Code 1597P (File #90.54)	
7. Author(s) James A. Mohamed-Ali				8. Performing Organization Report No. CDOH-DTD-R-90-13	
9. Performing Organization Name and Address Colorado Department of Highways Division of Transportation Development 4201 E. Arkansas Avenue Denver, Colorado 80222				10. Work Unit No. (TRAIS)	
				11. Contract or Grant No. DTFH 71-90-507-CO-22	
12. Sponsoring Agency Name and Address Colorado Department of Highways 4201 E. Arkansas Avenue Denver, Colorado 80222				13. Type of Report and Period Covered Construction Report	
				14. Sponsoring Agency Code	
15. Supplementary Notes Prepared in Cooperation with the U.S. Department of Transportation, Federal Highway Administration					
16. Abstract This report describes the construction sequence for installing three roadside safety hardware devices. The devices installed are 10-gauge guardrail, the Brakemaster End Terminal system, and the Crash-Cushion Attenuating Terminal (CAT) system. Implementation					
17. Key Words Crash-Cushion Attenuating Terminal, CAT, Brakemaster End Terminal, Attenuator, 10-Gauge Guardrail, Heavy Guardrail			18. Distribution Statement No Restrictions: This report is available to the public through the National Information Service, Springfield, Virginia 22161		
19. Security Classif. (of this report) Unclassified		20. Security Classif. (of this page) Unclassified		21. No. of Pages 33	22. Price

TABLE OF CONTENTS

Section	Page
I. Introduction	1
II. Background	1
III. 10-Gauge Guardrail	2
IV. Brakemaster End Terminal System	4
V. Crash-Cushion Attenuating Terminal System	6
VI. In-Service Evaluation	7
Appendices	Page
Appendix A, 10-Gauge Guardrail Installation Photos	8-10
Appendix B, Brakemaster Installation Photos	11-14
Appendix C, Crash-Cushion Installation Photos	15-16
Appendix D, Sketches	17-22

I. INTRODUCTION

This report, sponsored by the Federal Highway Administration, describes the construction sequence for installing three roadside safety hardware devices. They included 10-gauge guardrail on Project HES 0003(35), the Brakemaster End Terminal system on Project CX-0082-27, and the Crash-Cushion Attenuating Terminal (CAT) system on Project SR (CX) 0008(3).

II. BACKGROUND

The first device installed was the Type 3, 10-gauge W-beam guardrail, which is the same as standard 12-gauge W-beam guardrail except heavier. The standard W-beam used in Colorado often gets damaged by snowplowing operations and has to be replaced. By evaluating 10-gauge guardrail under real conditions, the department will decide its effectiveness in minimizing replacement costs compared to 12-gauge guardrail.

The location of the 10 and 12-gauge guardrail is on State Highway 24 about 20 miles south of Vail (Location Map, Page 17). The railing begins on Battle Mountain Pass (Photos A1 & A2) and extends south to the north end of Camp Hale (Photo A3).

Brakemaster, manufactured by Energy Absorption Systems Inc., and the CAT, manufactured by Syro Steel, are guardrail end terminals. They are designed for easy installation and low maintenance, and they are economical.

The locations of the Brakemaster End Terminals are south of Glenwood Springs on State Highway 82 at approximately the following mileposts: 2.5, 3.5, 5.2, 6.3, 11.9, and 12.2. The CAT system is in place on State Highway 8 and State Highway 285 just east of Morrison.

Cruz Construction of Colorado Springs installed the 10-gauge guardrail and section of 12-gauge guardrail during June 1990. Gonzales Construction of Dolores, Colorado, installed the Brakemasters during late July 1990; Haco Construction of Denver installed the CAT system in early October 1990.

III. 10-GAUGE GUARDRAIL

On the 10-gauge guardrail job, the contractor's crew started by removing as much of the existing rail as they could replace during the work day. For the entire job, this amounted to a total of about 8,344 linear feet of Type 1 (cable) and 288 feet of Type 3 (Sketch, Page 18). This removal also included about 31 end anchors.

They replaced this railing with the following planned quantities: 5,350 linear feet of 10-gauge galvanized guardrail, 4,150 linear feet of 10-gauge corrosion resistant guardrail, and 1,325 feet of 12-gauge corrosion resistant guardrail.

Corrosion resistant guardrail, also referred to as self-rusting steel, weathering steel, or self-weathering steel is steel that resists or opposes oxidation. It is often used aesthetically, because its reddish-brown surface blends with the landscape.

For a more detailed description of corrosion resistant steel, refer to ASTM designation A588, "High-Strength Low-Alloy Structural Steel." AASHTO M222 also describes the same standard specification for corrosion resistant steel.

Located as follows: 10-gauge galvanized guardrail begins at M.P. 149.93 and ends at M.P. 153.46, and 10-gauge corrosion

resistant guardrail begins at M.P. 153.79 and ends at M.P. 158.46. Most of this railing is on the west side of the road where there is mainly fill slope. A control section of 12-gauge corrosion resistant railing is on the east side of the road from M.P. 158.01 to M.P. 158.26 (Location Map, Page 17). This control section is in one of those few areas where there is fill on the east side of the road.

To begin the installation, the posts first had to be driven into the ground. The contractor did this with a post driver or "punch truck." This mechanical device is simply a truck with a bed-mounted hydraulic apparatus used for driving posts (Photo A4). From his seat and control panel, the punch truck operator drove the posts at their required spacing and depth.

Initially, one problem encountered in driving the steel posts was that the fill slopes were very rocky. This made it difficult to drive the posts directly into the ground and keep them square with the road. What the operator did to solve this problem was to drive a sleeve first, then a laborer could drop the steel post into the hole.

One other observation made while installing the 10-gauge guardrail was that the panels, being heavier, also took more time in handling (Photo A5). Each 25-foot panel of 10-gauge corrosion resistant steel weighs 221 pounds compared to 12-gauge that weighs 170 pounds; galvanized panels weigh 234 and 185 pounds respectively. Panels also were difficult to install around tight curves where, being less flexible, they had a tendency to kink.

Because of the problems mentioned, both the superintendent and project engineer estimated that installing 10-gauge

guardrail versus the 12-gauge took about 15 percent more time. Considering this, they installed an average of about 900 feet of 10-gauge guardrail per day. Along with increased labor time in using 10-gauge guardrail it also was more expensive. Using it cost an average of 6 to 9 percent more per linear foot compared to 12-gauge railing.

The bid price for installing 2,575 feet of railing at 6'-3" post spacing was \$12 per linear foot, and to install 8,250 feet of railing at 12'-6" post spacing cost \$9 per linear foot. These unit prices came off the bid tabulation sheet. The guardrail costs, provided by the supplier, Trinity Industries Inc., follow. Ten gauge corrosion resistant guardrail cost \$3.25 a linear foot, 10-gauge galvanized guardrail cost \$3.15 a linear foot, and 12-gauge corrosion resistant guardrail \$2.95 a linear foot.

According to Colorado Standard Plans, posts spaced at 6'-3" centers normally are for design speeds of 50 mph and over. Posts spaced at 12'-6" centers are specified for tangents or curves with radii over 200 feet where the design speed is less than 50 mph.

IV. BRAKEMASTER END TERMINAL SYSTEM

The Brakemaster End Terminal, designed for use in low-frequency impact areas and for easy installation, is another safety device under evaluation (Sketch, Page 19). At a bid price of \$5000 per terminal, this system's construction includes W-beam guardrail panels and a braking mechanism (Photo B1, - Sketch, Page 20). The design is such that the terminal moves back telescopically during a head-on impact bringing a vehicle to a controlled stop. Brakemaster also can redirect vehicles in low angle side hits.

Preparation for installing the Brakemaster End Terminals began during the week of July 22. This included the contractor having to dig six, 5 feet deep by 2 feet diameter holes at the head of each terminal section. Filled with concrete, these bases hold the embedded terminal anchors (Photo B2). This job took about two days to complete.

On the following Monday, the contractor began assembling the terminals. They installed four that day and possibly could have installed all six had it not been for a problem encountered with two of the anchors.

The two anchors in question had come from the manufacture with a slight fabricating error. The error was that the sleeve pipes came positioned on the uprights about one-half an inch lower than they should have (Sketch, Page 21). This made attaching the nuts to the threaded end of the cable assembly impossible. To solve this problem, the contractor chiseled out the concrete around the anchors. Doing this provided enough clearance to accommodate the nuts (Photo B3).

The next day, Tuesday, an engineer flew out from Energy Absorption's California facility to inspect the anchors and concrete bases. He concluded that they would be acceptable to use as they were. Upon receiving the engineers approval, the contractor then completed the job by installing the two remaining end terminals.

All six terminals have transitions that fasten to the ends of concrete barrier (Photo B4). These transitions consist of two overlapping W-beam guardrail panels on each side, giving the section added strength. The steel posts (Photo B5), spaced approximately 3 feet apart, support the weight of the transition panels (Photo B6).

Physically, the terminals are on horizontal alignments that vary slightly from almost straight to a gentle curvature. They are in narrow medians in bidirectional four-lane traffic where the road is almost flat (Photo B7).

V. CRASH-CUSHION ATTENUATING TERMINAL (CAT) SYSTEM

Tuesday, October 16, 1990, Haco Construction started installing the CAT system (Sketch, Page 22). This job began with the contractor first having to remove an existing end treatment (Photo C1). They first started by unscrewing the nuts and bolts from the panels and posts, easily done with a set of crescent wrenches. Then they removed the embedded posts from the ground.

After removing the old end treatment, the crew began the terminal assembly. They first started by driving the holes with the punch truck and then dropping the posts into the ground. They also used the punch truck to drive a required sleeve with vertical soil plate over each post (Photo C2). Driving this sleeve plate worked out fine because of the soft clayey soil. Lastly, they attached the panels and hardware to the post.

Haco's removal of the existing terminal system and installation of the new CAT system (Photo C3) took about a day and a half to complete. This all at a bid price of \$6510, \$4000 of which they spent on the system itself.

This system is on the north side of the bridge approach (Photo C4). It is in the middle of a two-lane road that carries bidirectional traffic. The median that separates the two lanes is 5.5 feet wide.

VI. IN-SERVICE EVALUATION

An in-service evaluation will be conducted on the devices' performance over the next two years. This will involve periodic inspections to document any problems or advantages that may be seen. It also will include investigating any accidents that might affect the function and purpose of any of the devices.

This safety evaluation will be monitored with the help of maintenance crews who work these particular sections of highway where the devices are located. They are aware of the study and have agreed to notify the Research Branch of any problems involving the terminals or guardrail.

APPENDIX A

10-GAUGE GUARDRAIL PHOTOS



Photo A1. View of Battle Mountain Pass.



Photo A2. 10-gauge galvanized guardrail on Battle Mountain Pass.



Photo A3. 10-gauge corrosion resistant guardrail with view of Camp Hale in the background.



Photo A4. Back end of the "Punch Truck."



Photo A5. Two men positioning a guardrail panel for installation.

APPENDIX B

BRAKEMASTER END TERMINAL PHOTOS

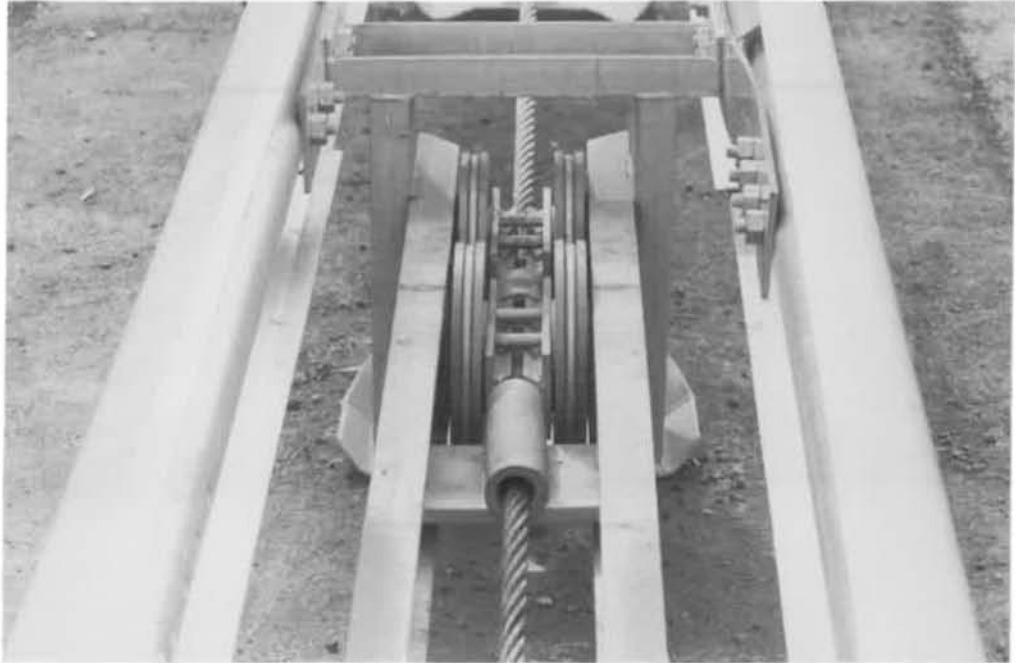

Photo B1. Brakemaster's braking mechanism.

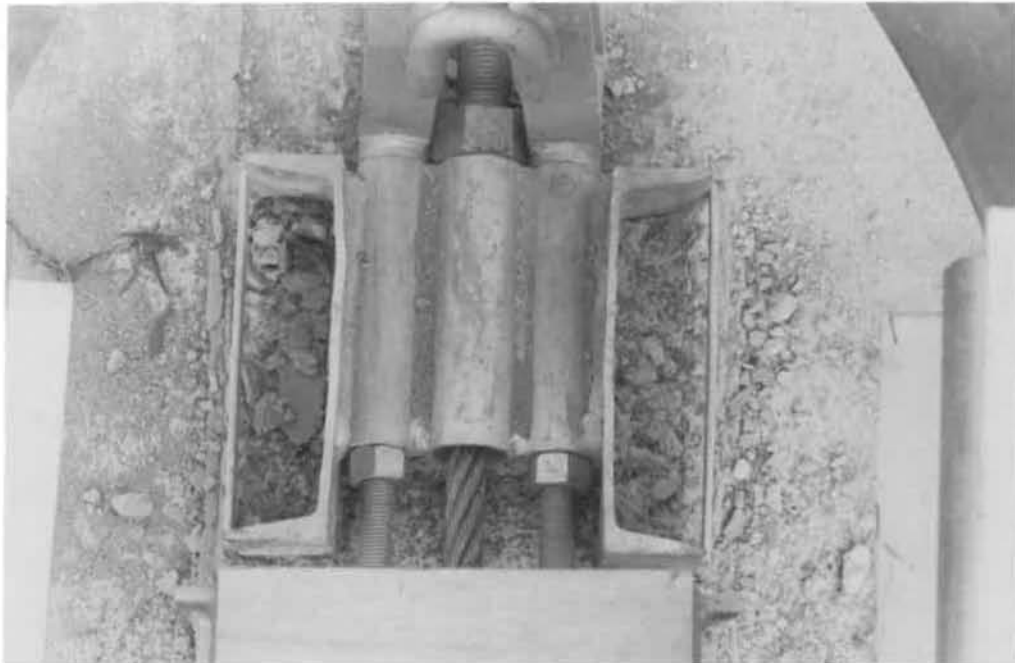

Photo B2. Top view of embedded terminal anchor.

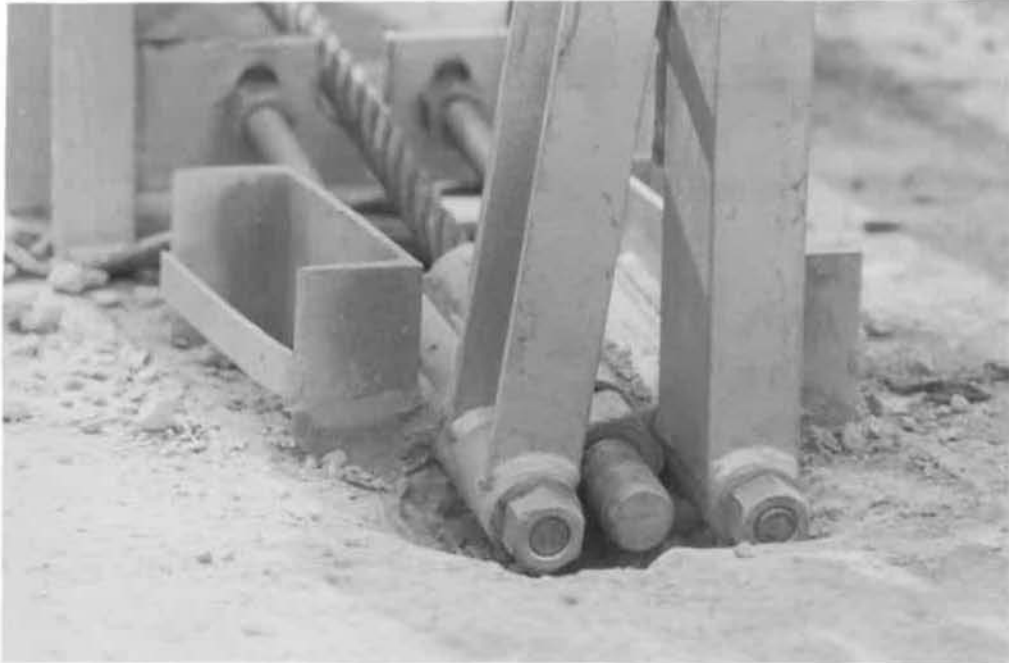

Photo B3. Side view of embedded terminal anchor.



Photo B4. Brakemaster transition section fastened to concrete barrier.



Photo B5. A steel post in the transition section.

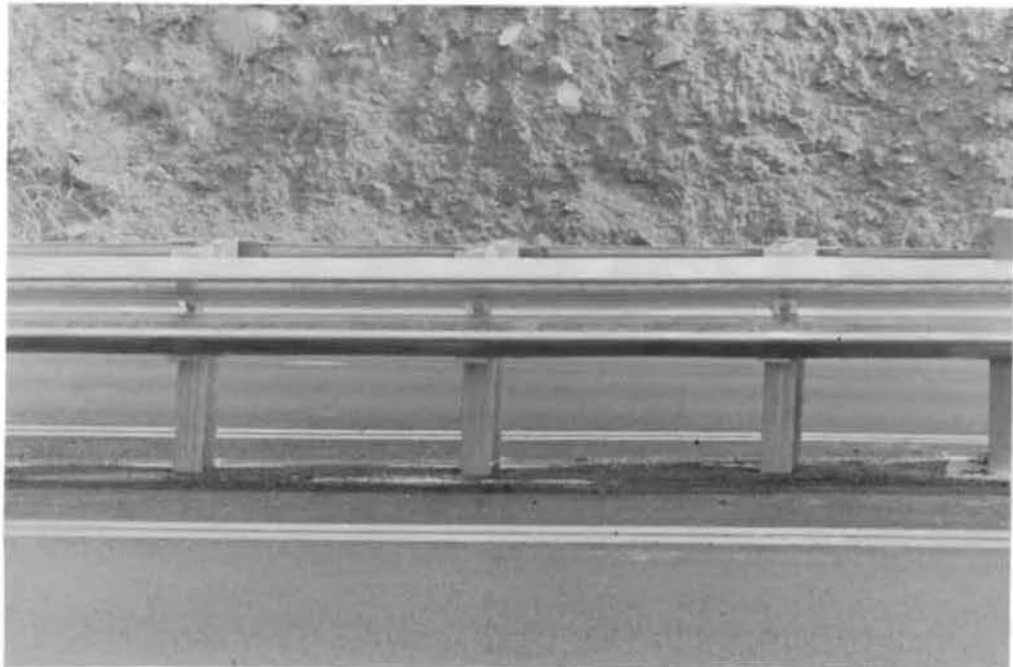

Photo B6. The transition section with overlapping panels on each side.



Photo B7. Completed Brakemaster End Terminal.

APPENDIX C

CRASH-CUSHION END TERMINAL PHOTOS



Photo C1. Crew removing old end treatment.



Photo C2. Vertical soil plate and sleeve that is placed over wooden post.



Photo C3. Side view of Crash-Cushion Attenuating Terminal (CAT) system.



Photo C4. Front view of CAT Terminal.

APPENDIX D

SKETCHES

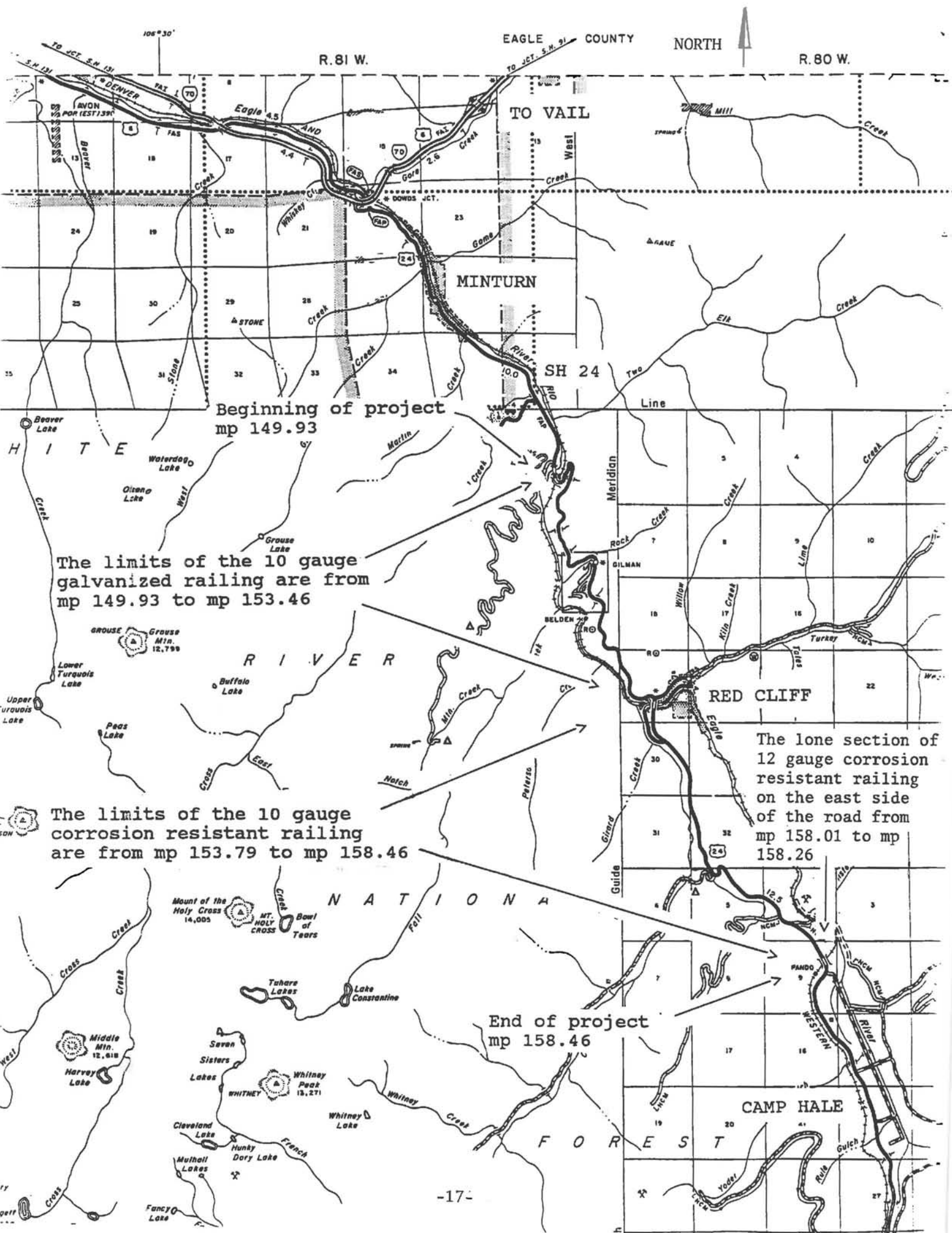

EAGLE COUNTY NORTH

R. 81 W.

R. 80 W.

TO VAIL

MINTURN

SH 24

Beginning of project
mp 149.93

The limits of the 10 gauge
galvanized railing are from
mp 149.93 to mp 153.46

R I V E R

RED CLIFF

The lone section of
12 gauge corrosion
resistant railing
on the east side
of the road from
mp 158.01 to mp
158.26

The limits of the 10 gauge
corrosion resistant railing
are from mp 153.79 to mp 158.46

End of project
mp 158.46

N A T I O N A L

CAMP HALE

F O R E S T

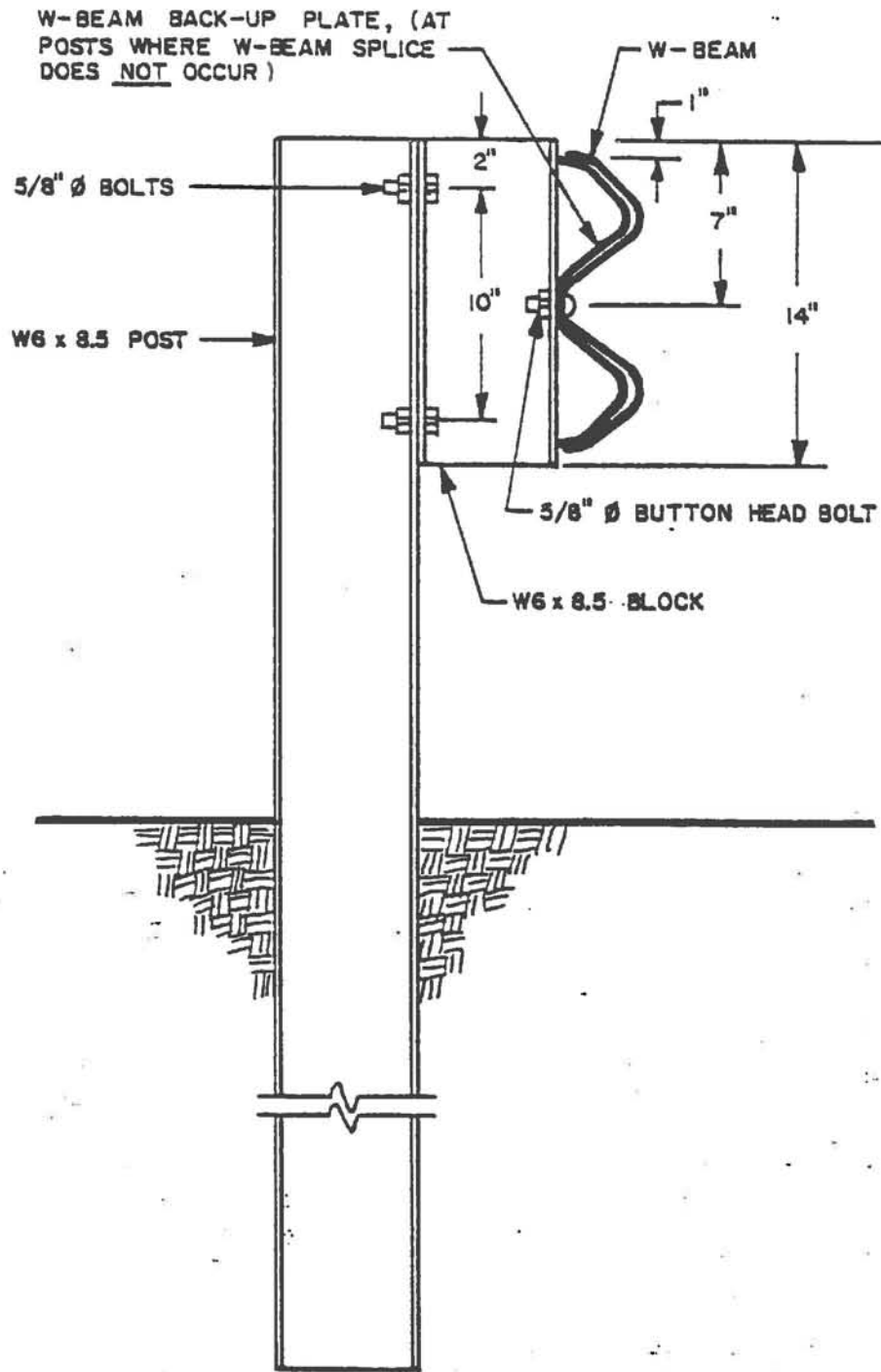

STANDARD W-BEAM GUARDRAIL

CAUTION: DO NOT ATTACH THE BRAKEMASTER SYSTEM DIRECTLY TO A RIGID CONCRETE BARRIER. A GUARDRAIL TRANSITION SECTION IS REQUIRED. CONTACT ENERGY ABSORPTION SYSTEMS AT (312) 467-6750 FOR MORE INFORMATION.

VARIOUS TRANSITION DESIGNS ARE AVAILABLE. CONTACT ENERGY ABSORPTION SYSTEMS, INC. FOR FURTHER DETAILS OR FOLLOW LOCAL DOT TRANSITIONS.

BIDIRECTIONAL INSTALLATION SHOWN

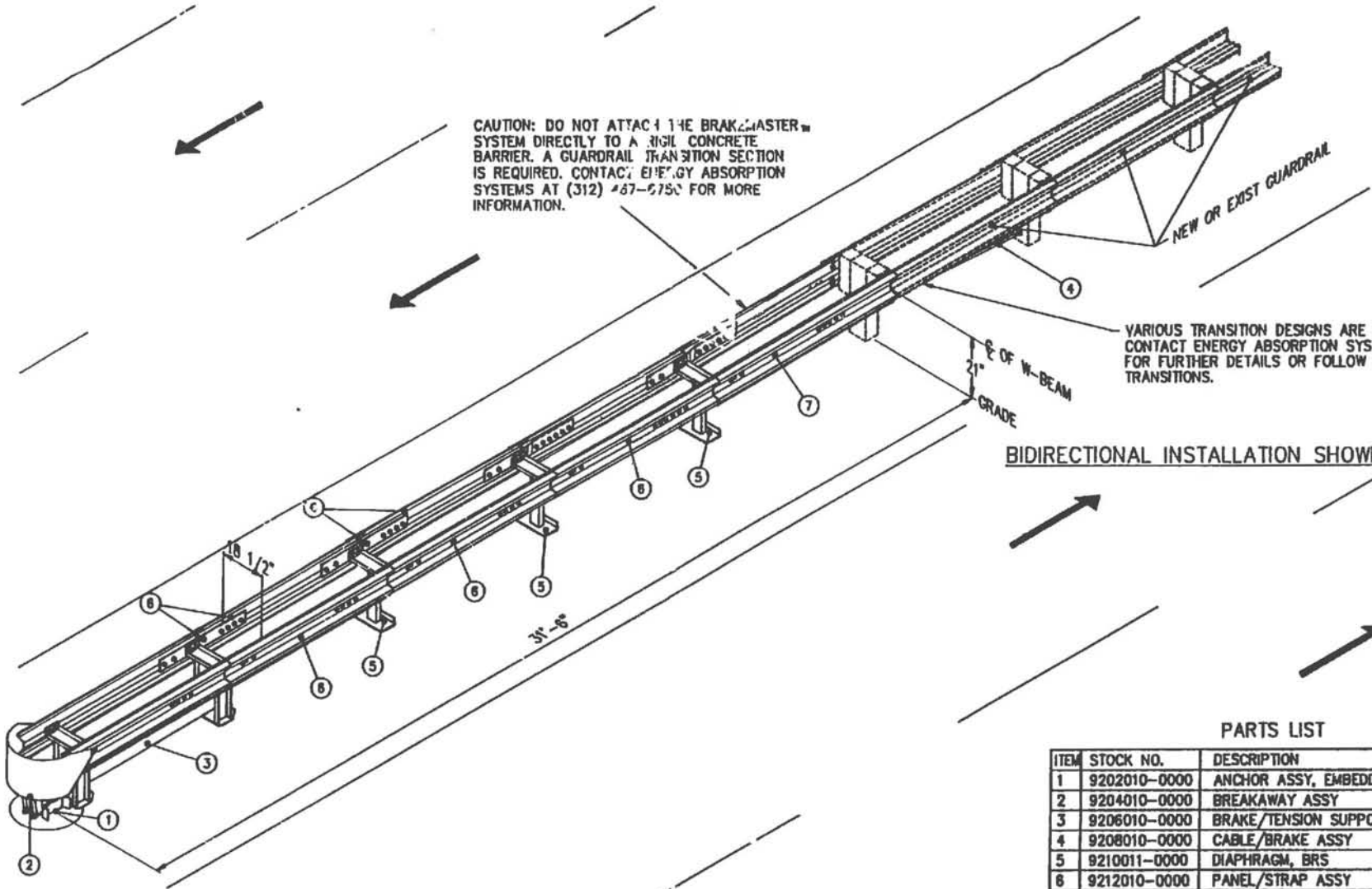

PARTS LIST

ITEM	STOCK NO.	DESCRIPTION	REQ'D
1	9202010-0000	ANCHOR ASSY, EMBEDDED, BRS	1
2	9204010-0000	BREAKAWAY ASSY	1
3	9206010-0000	BRAKE/TENSION SUPPORT ASSY	1
4	9208010-0000	CABLE/BRAKE ASSY	1
5	9210011-0000	DIAPHRAGM, BRS	3
6	9212010-0000	PANEL/STRAP ASSY	6
7	9214010-0000	TRANSITION STRAP ASSY	2

MODEL NO. 106106BRSS

ENERGY ABSORPTION SYSTEMS, INC.
ENGINEERING AND RESEARCH DEPARTMENT

**BRAKEMASTER
GENERAL ASSEMBLY
(BIDIRECTIONAL SYSTEM)**

PARTS LIST			
ITEM	STOCK NO.	DESCRIPTION	REQ'D
1	9208021-0000	BRAKE ASSY	2
2	9208031-0000	CABLE ASSY, BRS	1
3	2708671-0000	WASHER, BAR, 3/4 x 8 x 8	1
4	2708491-0000	WASHER, BAR, 1/4 x 3 x 3, G	3
5	9208101-0000	SPACER, BRS	3

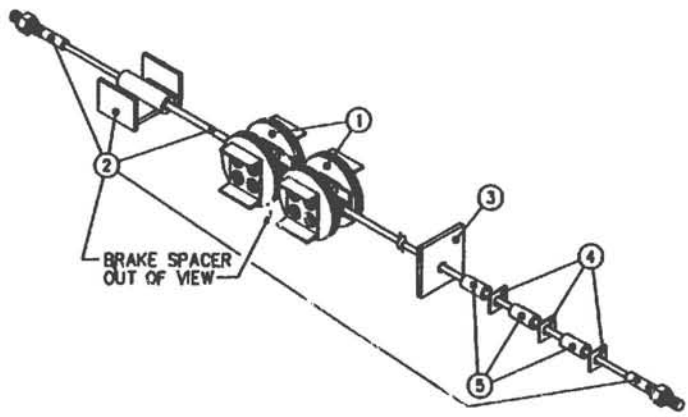
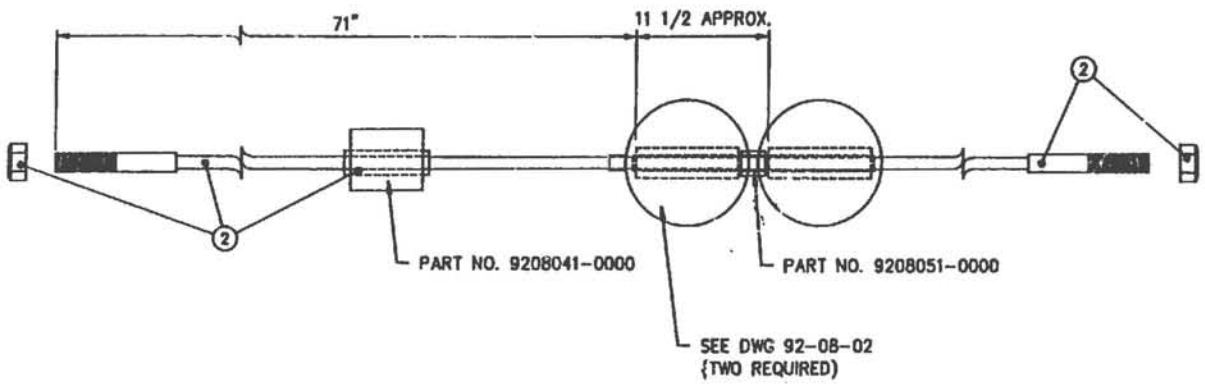

NOTES:
ITEMS 3 THRU 5 SHIPPED DISASSEMBLED

ASSEMBLY NO. 9208010-0000

<p>ENERGY ABSORPTION SYSTEMS, INC. ENGINEERING AND RESEARCH DEPARTMENT</p>
<p>BRAKEMASTER CABLE/BRAKE ASSEMBLY</p>

FRONT

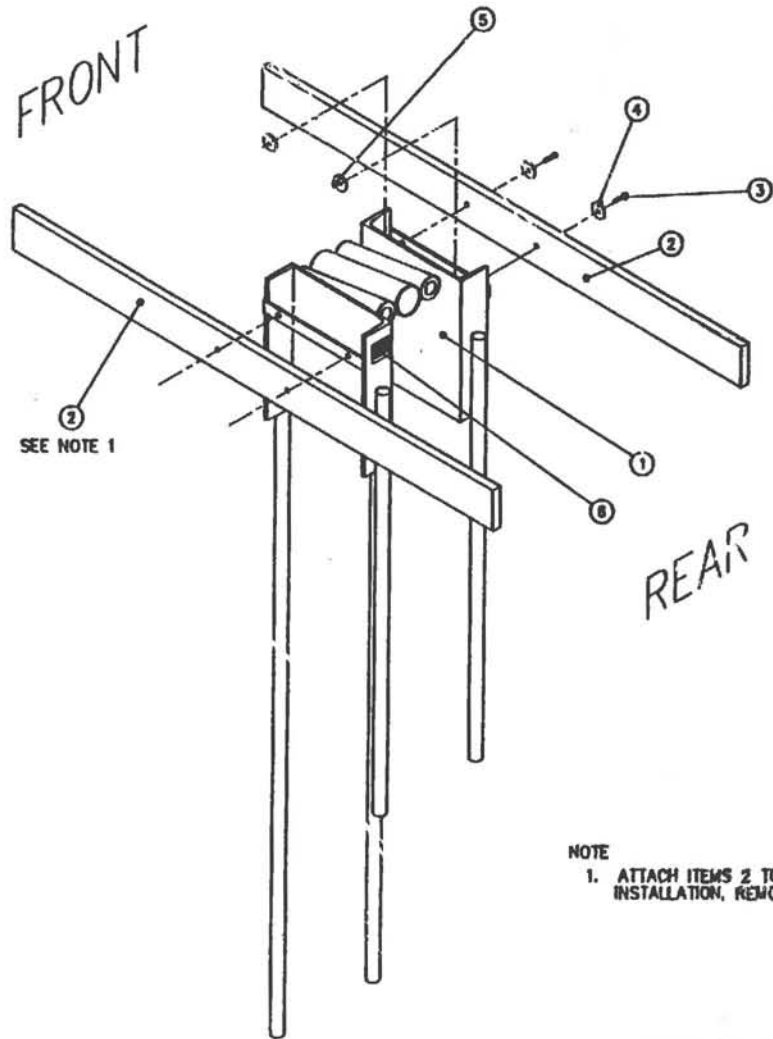

PARTS LIST			
ITEM	STOCK NO.	DESCRIPTION	QTY
1	9202021-0000	ANCHOR, EMBEDDED, BRS	1
2	9202031-0000	SUPPORT, WOOD, 1 x 4 x 48	2
3	2708451-0000	SCREW, HXW, 1/4 x 1 3/4, G	4
4	2708271-0000	WASHER, FLAT, 1/4 x 1 1/2, G	4
5	2704041-0000	NUT, WASHER, G	4
6	2735651-0000	DECAL, EMBEDDED ANCHOR	1

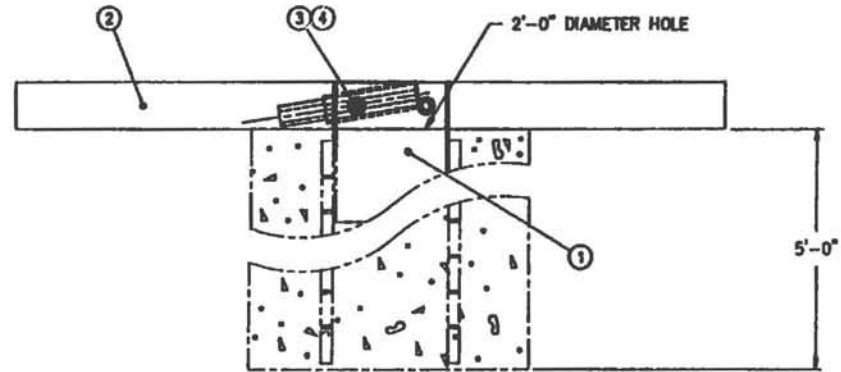

NOTE

1. ATTACH ITEMS 2 TO ITEM 1 AS SHOWN PRIOR TO INSTALLATION, REMOVE AFTER CONCRETE HAS SET.

CAUTION: Proper placement of this assembly is critical to the final assembly of the system. Read and follow the installation instructions.

ASSEMBLY NO. 9202010-0000

ENERGY ABSORPTION SYSTEMS, INC.
ENGINEERING AND RESEARCH DEPARTMENT

**BRAKEMASTER
ANCHOR ASSY, EMBEDDED, BRS**

DESCRIPTION:
**CRASH-CUSHION
 ATTENUATING
 TERMINAL**

ITEM	DESCRIPTION
1	NOSE SECTION
2	12 GA. SLOTTED RAILS
3	10 GA. SLOTTED RAILS
4	BACKUP RAILS
5	ANCHOR CABLE
6	SPACER CHANNEL
7	RESTRAINT ROD
8	KNOCKOUT BLOCK
9	SPECIAL SHEAR BOLTS W/ PLATE WASHERS
10	TREATED WOOD POSTS & BLOCKS
11	CHANNEL STRUT
12	FOUNDATION TUBE W/ SOIL PLATE
13	LINE POSTS

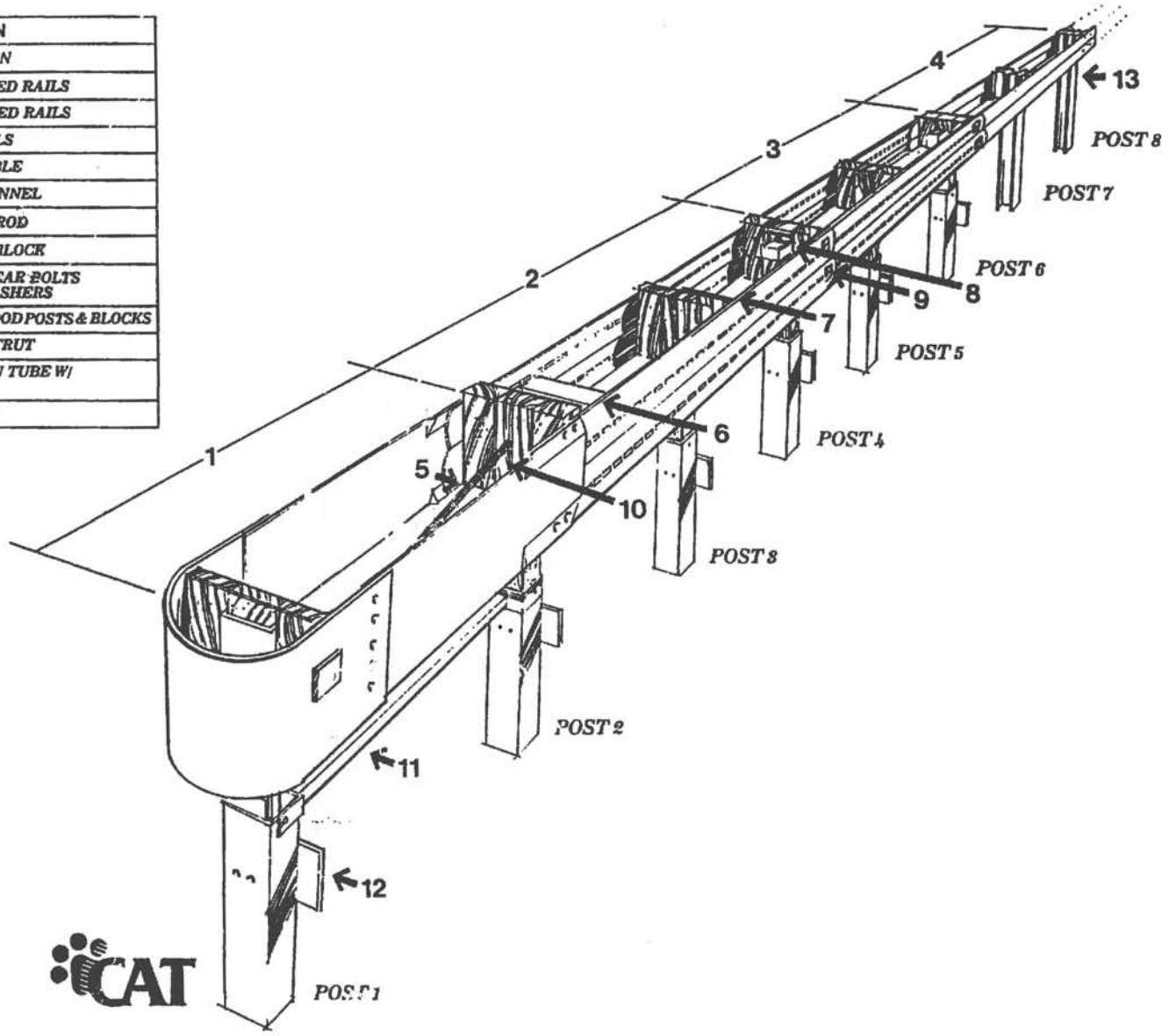

SYRO

Syro Steel Company
 GIRARD, OHIO 44420
 216-545-4373
 800-321-2755
 CENTERVILLE, UTAH 84014
 801-292-4461
 800-772-SYRO