

Report No. CDOT-DTD-97-12

LONG-TERM FIELD PERFORMANCE OF GEOSYNTHETIC-REINFORCED SOIL RETAINING WALLS

**Phillip E. Crouse
Jonathan T.H. Wu
Center for Mechanically Stabilized Backfill Research
University of Colorado at Denver**

**Final Report
May 1996**

**Prepared in cooperation with the
U.S. Department of Transportation
Federal Highway Administration**

The contents of this report reflect the views of the author who is responsible for the facts and the accuracy of the data presented herein. The contents do not necessarily reflect the official views of the Colorado Department of Transportation or the Federal Highway Administration. This report does not constitute a standard, specification, or regulation.

REPORT DOCUMENTATION PAGEFORM APPROVED
OMB NO. 0704-0188

Public reporting burden for this collection of information is estimated to average 1 hour per response, including the time for reviewing instructions, searching existing data sources, gathering and maintaining the data needed, and completing and reviewing the collection of information. Send comments regarding this burden estimate or any other aspect of this collection of information, including suggestions for reducing this burden, to Washington Headquarters Services, Directorate for Information Operations and Reports, 1215 Jefferson Davis Highway, Suite 1204, Arlington, VA 22202-4302, and to the Office of Management and Budget, Paperwork Reduction Project (0704-0188), Washington, DC 20503.

1. AGENCY USE ONLY (Leave Blank)

2. REPORT DATE

May 1996

3. REPORT TYPE AND DATES COVERED

4. TITLE AND SUBTITLE

Long-Term Field Performance of Geosynthetic-Reinforced Soil Retaining Walls

5. FUNDING NUMBERS

6. AUTHOR(S)

Phillip E. Crouse and Jonathan T. H. Wu

7. PERFORMING ORGANIZATION NAME(S) AND ADDRESS(S)

Center for Mechanically Stabilized Backfill Research
University of Colorado at Denver8. PERFORMING ORGANIZATION
REPORT NUMBER

CDOT-DTD-97-12

9. SPONSORING/MONITORING AGENCY NAME(S) AND ADDRESS(S)

Colorado Department of Transportation
4201 E. Arkansas Ave.
Denver, Colorado 8022210. SPONSORING/MONITORING
AGENCY REPORT NUMBER

CDOT-DTD-97-12

11. SUPPLEMENTARY NOTES

Prepared in Cooperation with the U.S. Department of Transportation, Federal
Highway Administration

12a. DISTRIBUTION/AVAILABILITY STATEMENT

No Restrictions: This report is available to the public through the
National Technical Information Service. Springfield, VA 22161

12b. DISTRIBUTION CODE

13. ABSTRACT (Maximum 200 words)

A study was undertaken to synthesize field long-term performance data of full-scale geosynthetic-reinforced soil (GRS) retaining walls. Upon conducting an extensive literature review and survey, seven GRS retaining walls of which the performance had been monitored for extended periods of time were selected for this study. To assess the wall performance, a conservatism index (CI) was defined to quantify the relative degree of conservativeness of the walls. In addition, a simple analytical equation was developed for predicting creep deformation of a GRS wall beyond the measurement period. The analytical equation was derived based on the synthesized behavior of the GRS walls that the logarithmic creep rate decreased linearly with logarithmic time.

This study conclusively indicated that all the GRS retaining walls with granular backfill deformed very little due to creep and were stabilizing with time. The current design methodology to account for creep is overly conservative when well-compacted granular backfill is employed. Using results of a soil-geosynthetic composite performance test in conjunction with the analytical equation, long-term creep deformation of a GRS wall under project specific conditions can be predicted in a rational manner throughout its design life.

14. SUBJECT TERMS

Creep deformation
Geosynthetic
Retaining Wall

15. NUMBER OF PAGES

112

16. PRICE CODE

17. SECURITY CLASSIFICATION
OF REPORT

Unclassified

18. SECURITY CLASSIFICATION
OF THIS PAGE

Unclassified

19. SECURITY CLASSIFICATION
OF ABSTRACT

Unclassified

20. LIMITATION OF ABSTRACT

CONTENTS

<u>Chapter</u>	
1. Introduction	1
1.1 Background	4
1.2 Research Need	5
1.3 Research Objectives.....	6
1.4 Report Organization.....	7
2. Literature Review and Survey of Creep Performance in GRS Retaining Walls	8
2.1 Project Descriptions.....	11
2.1.1 Interstate Highway 70 through Glenwood Canyon Project	12
2.1.2 Tanque Verde - Wrightstown - Pantano Roads Project	14
2.1.3 Norwegian Geotechnical Institute Project	15
2.1.4 Japan Railway Test Embankment Project.....	16
2.1.5 Highbury Avenue Project.....	16
2.1.6 Federal Highway Administration Research Project	17
2.1.7 Seattle Preload Fill Project.....	17
2.2 Design Approach Evaluation	18
2.2.1 External and Internal Stability.....	18
2.2.2 Lateral Forces	19
2.2.3 Reinforcement Tensile Strength	21
2.2.4 Partial Factors of Safety	29
2.2.5 Facing Rigidity	1

3. Project Long-Term Performance.....	34
3.1 Instrumentation and Measured Parameters.....	34
3.2 Reinforcement Strains and Wall Movement.....	35
3.2.1 Interstate Highway 70 through Glenwood Canyon Project.....	35
3.2.2 Tanque Verde - Wrightstown - Pantano Roads Project	38
3.2.3 Norwegian Geotechnical Institute Project	41
3.2.4 Japan Railway Test Embankment Project.....	43
3.2.5 Highbury Avenue Project.....	45
3.2.6 Federal Highway Administration Research Project	45
3.2.7 Seattle Preload Fill Project.....	46
3.3 Conservatism Index.....	51
3.3.1 Creep-Rate and the Creep Modulus.....	53
4. An Approach to Estimating Creep Using a Laboratory Test	58
4.1 Creep in Laboratory Tests	58
4.1.1 Laboratory Creep Test Descriptions.....	59
4.1.2 Laboratory Test Creep Rate	64
4.2 Laboratory and Full-Scale Creep Rate Comparison	67
4.3 An Analytical Solution for Estimating Creep Strain	70
5. Summary and Conclusions	34
5.1 Summary	73
5.2 Conclusions.....	73
5.3 Recommendations for Future Study.....	74

Appendix

A. Project Description Sheets 76
B. Conservatism Index Calculation Brief 84
C. Plots used to compute the creep modulus..... 97

References 108

TABLES

Table

2.1.	Selected Full-Scale Field GSR Retaining Wall Projects.....	9
2.2.	Reinforcement Tensile Strength in Selected Projects.....	22
3.1.	CRC, Reinforcement Strain and Wall Movement for the Selected Projects	37
3.2.	Parameters Used to Compute the Conservatism Index.....	52
3.3.	Creep Modulus for the Selected Projects.....	57
4.1.	Creep Modulus for the Full-Scale Walls and Laboratory Tests	69

FIGURES

Figure		
1.1.	Components of a GRS Retaining Wall	3
2.1.	GRS Retaining Wall Project Location Map.....	10
2.2.	Wall Profiles for Selected GRS Retaining Wall Projects	13
2.3.	Forces Using the Tie-Back Wedge Method	20
2.4.	Parameters of a Geosynthetic Stress-Strain Curve	24
3.1.	Reinforcement Creep-Time Curves for the Tanque - Verde - Tanque - Wrightstown - Pantano Roads Project	40
3.2.	Reinforcement Creep-Time Curves for the Norwegian Geotechnical Institute Project	42
3.3.	Tensile Force in Reinforcement and Displacement for the Japan Railway Test Embankment Project.....	44
3.4.	Reinforcement Creep-Time Curve for the Highbury Avenue Project.....	48
3.5.	Reinforcement Creep-Time Curve for the FHWA Project	49
3.6.	Reinforcement Creep-Time Curve for the Seattle Preload Fill Project.....	50
3.7.	Creep-rate-Time Curve Illustrating the Creep Modulus.....	54
3.8.	Creep-Rate-Time Curve for the Selected Projects.....	55
4.1.	Schematic of the Long-Term Soil/Geosynthetic Performance Test Device (Helwany and Wu, 1996).....	61
4.2.	Schematic of the Modified Soil/Geosynthetic Performance Test Device (Ketchart and Wu 1996)	62
4.3.	Creep-Rate-Time Ratio Plot	70

1. Introduction

Retaining walls have become an increasingly popular method for retaining earth to accommodate worldwide development of transportation and other structural systems. Conventional gravity and cantilever retaining walls that externally resist lateral earth pressure can be costly and difficult to build because of their large rigid mass. However, a new type of retaining wall is available that derives its stability from within the backfill (i.e., is internally stabilized) and is demonstrating distinct advantages over conventional retaining walls.

In France, H. Vidal introduced modern applications of soil-reinforced retaining walls in the 1960s (Vidal, 1966) using metal strips for reinforcement. The idea of internally stabilizing soil is to strengthen the soil mass by the inclusion of planar reinforcement whose function it is to restrain the development of tensile strain in the direction of the reinforcement. Reinforcement can be inextensible (e.g., metals) or extensible (e.g., geosynthetics). Since 1980, geosynthetics have been used for reinforcement due to their flexibility and low cost. Soil reinforced with geosynthetics is referred to as geosynthetic reinforced soil (GRS). Some of the advantages of GRS retaining walls over conventional retaining structures include:

- Their flexibility allows greater tolerance to foundation settlement;
- Construction of GRS walls is rapid and requires only "ordinary" construction equipment; and
- GRS retaining walls are generally more economical than conventional retaining walls.

The primary components in a GRS retaining wall include the reinforcement, wall facing, reinforced soil backfill, retained soil, and

foundation soil. Figure 1.1 illustrates these components in a typical GRS retaining wall.

Since the development of GRS technology, researchers have identified three characteristics that are not well understood when reinforcing soil with geosynthetic material. These include:

- Lateral earth pressure distribution;
- Failure surface; and
- Creep.

This study focuses on creep in a GRS retaining wall. Lateral earth pressure distribution and the failure surface have been addressed by several other researchers and is ongoing.

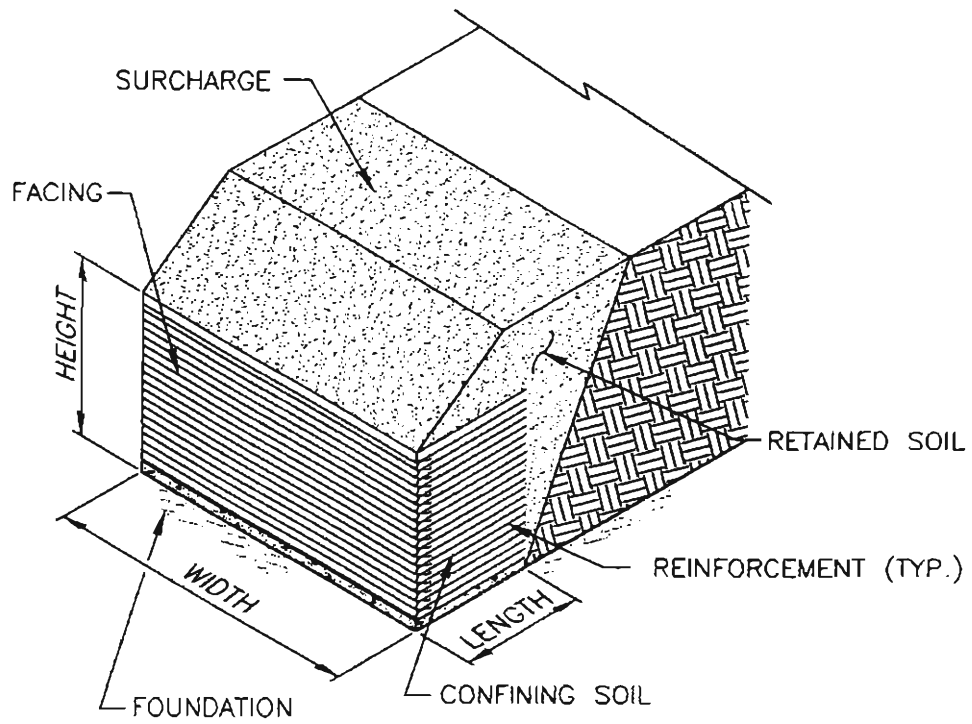

Figure 1.1
Components of a GRS Retaining Wall

1.1 Background

Since the mid-1980s researchers have attempted to characterize the long-term behavior of GRS retaining walls. The overall research objective has been to understand their long-term behavior to guide the development of rational methods of analysis and design. Although this has been the overall objective, researchers have approached the problem from three different aspects:

- Instrumenting full-scale GRS retaining walls;
- Soil/geosynthetic composite laboratory creep tests; and
- Element laboratory creep tests of geosynthetics.

Since the 1960s numerous full-scale GRS retaining walls have been built and instrumented to quantify their performance. However, these walls typically were monitored for relatively short periods of time due to financial constraints and/or instrumentation damage. Since the late 1980s researchers have built a few full-scale GRS retaining walls that have been monitored for extended periods of time to quantify their long-term performance. The results from these instrumented walls have been individually documented, but have never been investigated in a unified manner.

In 1994 a soil/geosynthetic composite laboratory creep test was developed by Wu (1994a) and Wu and Helwany (1996) to characterize the complex behavior of the soil/geosynthetic composite. The test simulates the composite by transferring stresses applied to the soil in a manner similar to the typical load transfer mechanism in a GRS retaining wall. Ketchart and Wu (1996) continued the research by developing a simple test procedure to assess the long-term behavior of GRS walls and tested various soils and reinforcement materials under different conditions.

The current state of practice is to account for creep by performing a creep test on the reinforcing element. Laboratory tests such as the procedure contained in the American Society for Testing and Materials (ASTM) D5262 Test Method entitled "Tension Creep Testing of Geotextiles" is used to determine a creep-limited strength of the reinforcement elements. The test consists of applying a constant load for a minimum duration of 10,000 hours to an eight-inch-wide specimen. Because of the obvious time-constraint of the test, estimated creep-limited strengths are typically used for GRS retaining wall designs instead of performing the actual test. The creep-limited strength is computed by applying a creep reduction coefficient (CRC) or partial factor of safety to the geosynthetics' short-term strength. Current American Association of State Highway and Transportation Officials (AASHTO) design methods recommend reducing the short-term strength by as much as 20 to 80 percent to account for creep.

The fundamental assumption in using results from geosynthetic creep tests is that the soil/geosynthetic composite wall will behave the same as the reinforcement element. However, results from full-scale and laboratory tests have revealed that the geosynthetics perform significantly better when confined in GRS walls than predicted by the element creep tests due to stress redistribution in the soil/geosynthetic composite. Because of this discrepancy, current design methods are overconservative and are inhibiting the development of GRS technology.

1.2 Research Need

Since geosynthetics are creep-sensitive materials, designers are concerned about providing adequate margins of safety to account for creep in permanent GRS retaining wall applications. This, along with the lack

of quantitative long-term performance data has led to the misunderstanding of the complex behavior of the soil/geosynthetic composite resulting in overconservative designs. Therefore, the first research need is to compile existing, quantitative, long-term performance data, from full-scale, well-instrumented GRS retaining walls. The second research need is to develop a rational method for estimating creep for the design life of the structure based on the creep behavior of the soil/geosynthetic composite instead of the geosynthetic element alone.

1.3 Research Objectives

The three main research objectives include:

1. Compile long-term performance data from field projects involving well-instrumented GRS retaining walls;
2. Develop a means to quantify the conservativeness of the designs; and
3. Develop a rational method to estimate creep based on laboratory creep test of the soil/geosynthetic composite deformation

To meet the first objective, the following tasks were performed:

- An extensive literature search was performed to determine what projects could be used for the study of long-term performance;
- A request for information was sent to experts in GRS technology;
- Specific projects were selected for the study; and
- Specific design and performance data from the selected projects were compiled and summarized.

To meet the second objective, the following tasks were performed:

- The actual or design creep reduction to the reinforcements' tensile strength is compared to reductions recommended by AASHTO;
- A conservatism index (CI) was developed to quantify the conservativeness of the design and;

- A simple procedure was developed to predict creep using a simple laboratory test and analytical equation can be used to predict creep

To meet the third objective, the following tasks were performed:

- The laboratory test procedure used to model the creep behavior of the soil/geosynthetic composite was described;
- The laboratory creep tests were validated using the performance of the selected projects; and
- A rational procedure was developed using the laboratory test and analytical equation to estimate creep for the design life of a GRS retaining wall.

1.4 Report Organization

Chapter 1 presents the introduction, background, research needs and research objectives. Chapter 2 describes the projects selected from the literature survey. Chapter 3 describes the design and long-term performance of the selected projects. Chapter 4 describes the method to estimate creep using the laboratory soil/geosynthetic model creep tests. Chapter 5 describes the conclusions and recommended future research. Appendix A contains the selected project descriptions. Appendix B contains the conservatism index computation and Appendix C contains the graphs used to compute the creep modulus.

2. Literature Review and Survey of Creep Performance In GRS Retaining Walls

Since the 1960s researchers have built and instrumented numerous full-scale soil-reinforced retaining walls to quantify their performance. However, due to financial constraints and/or instrumentation damage, researchers could monitor the wall performance for only relatively short periods of time. In the 1980s, transportation officials began using GRS retaining walls for highway and railway renovation projects and sponsoring research in GRS technology. With support from the transportation resources, researchers installed instruments in some of these walls to monitor their long-term performance under actual service and field conditions.

In this study, an extensive literature review and survey was conducted to collect information on the projects that used GRS retaining walls that had been monitored for extended periods of time (i.e., greater than six months). A survey was developed and sent to 10 internationally renowned experts to obtain information on GRS projects under their direction. From the literature review and survey, seven GRS retaining wall projects were selected. These projects typically had well-documented, long-term reinforcement strain data, wall deformation data, and design data. The projects selected are listed in Table 2.1. The locations of the projects are illustrated on Figure 2.1.

Table 2.1
Selected Full-Scale Field GRS Retaining Wall Projects

Project	Constructed	Monitoring Duration	Location	Principal Researcher
Interstate Highway 70 through Glenwood Canyon	1982	7 months	Glenwood Springs, Colorado, USA	R. Barrett
Tanque Verde-Wrightstown-Pantano Roads	1985	7 years	Tucson, Arizona, USA	J. Collin
Norwegian Geotechnical Institute	1987	4 years	Oslo, Norway	R. Fannin
Japan Railway Test Embankment	1987	2 years	Tokyo, Japan	F. Tatsuoka
Highbury Avenue	1989	2 years	London, Ontario, Canada	R. Bathhurst
Federal Highway Administration	1989	1.3 years	Algonquin, Illinois, USA	M. Simac
Seattle Preload Fill	1989	1 year	Seattle, Washington, USA	T. Allen

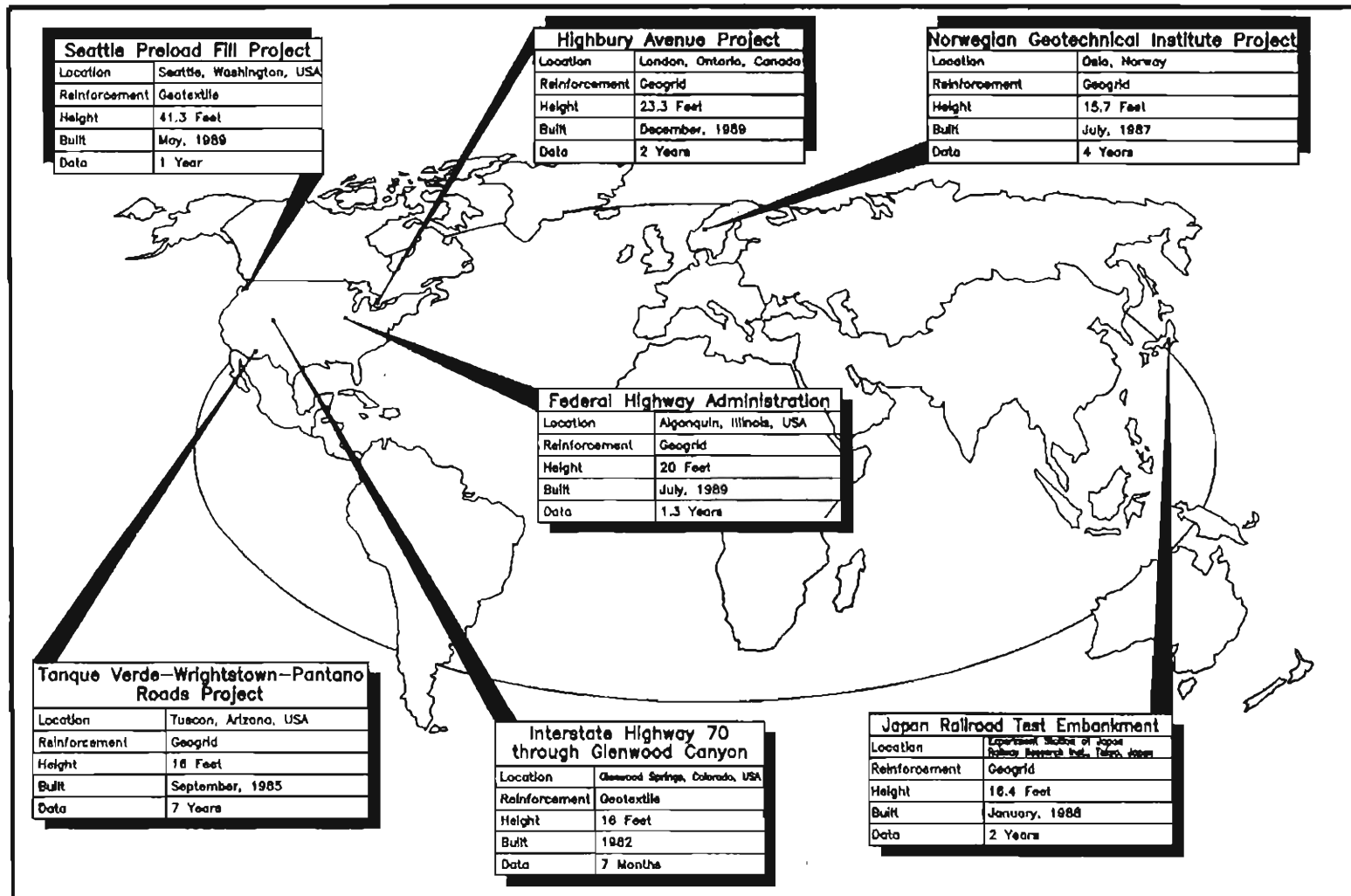

Figure 2.1
GRS Retaining Wall Project Location Map

The walls built for each project represent a variety of GRS retaining walls. The walls range from 15 feet to over 40 feet in height and typically include surcharge loads comprised of earth fills or highway loads. Reinforcement materials consist of polypropylene or polyester geogrids and geotextiles ranging in short-term strength from 400 to over 12,000 lb per foot width. The facing used on the walls consists of concrete modular blocks and panels or exposed surfaces. Some of the walls are constructed on poor foundations while others are constructed on competent foundation materials. The environmental conditions vary from freezing temperatures in Ontario, Canada, to temperatures up to 111° Fahrenheit for walls built in the state of Arizona, USA.

Although the selected projects consist of a variety of GRS retaining wall types, all the walls performed exceptionally well. The maximum strains measured in the reinforcement in all cases were less than five percent. In some cases, the designs predicted strains of 40 to 60 percent. In other cases, the walls were designed to fail, yet failure could not be achieved. The following sections provide a brief description of the selected projects and design approach. Chapter 3 provides the performance evaluation.

2.1 Project Descriptions

The following sections provide a brief overview of the projects selected from the literature review and survey. The GRS retaining walls built for each project are illustrated on Figure 2.2. Selected project information is provided on project description sheets in Appendix A. The project description sheets include information such as the wall components (i.e., confining soil, facing, and reinforcement type), reinforcement strength, surcharge, and schedule showing dates of milestone events such as the

beginning of construction, surcharge loading, and monitoring period. A schematic of the retaining wall(s) and project photographs are also included on the project description sheets.

2.1.1 Interstate Highway 70 through Glenwood Canyon Project

In April of 1982, the Colorado Department of Highways designed and constructed a series of internally reinforced walls for the Interstate Highway 70 project through Glenwood Canyon. The Glenwood Canyon follows the Colorado River through the scenic Rocky Mountains of Colorado, USA, near the city of Glenwood Springs. The retaining walls were built over highly compressible silts and clays at the base of the canyon. Because of architectural and environmental constraints, transportation officials tested a series of internally reinforced retaining walls including a reinforced earth wall, retained earth wall (VSL), a wire-mesh reinforced wall, and a geotextile-reinforced wall. The geotextile reinforced wall was one of the first full-scale GRS walls constructed in the USA.

The performance of the GRS retaining wall was observed for several years; however, quantitative performance data was documented for only the first seven months of service. The wall was designed to determine the lower stability limits of a GRS retaining wall, therefore geotextiles having relatively low tensile strengths (i.e., 400 to 900 lb/ft) were used for the reinforcement. In June, 1983, a 15 foot high surcharge was applied to the top of the wall in an attempt to collapse the wall. However, failure never occurred.

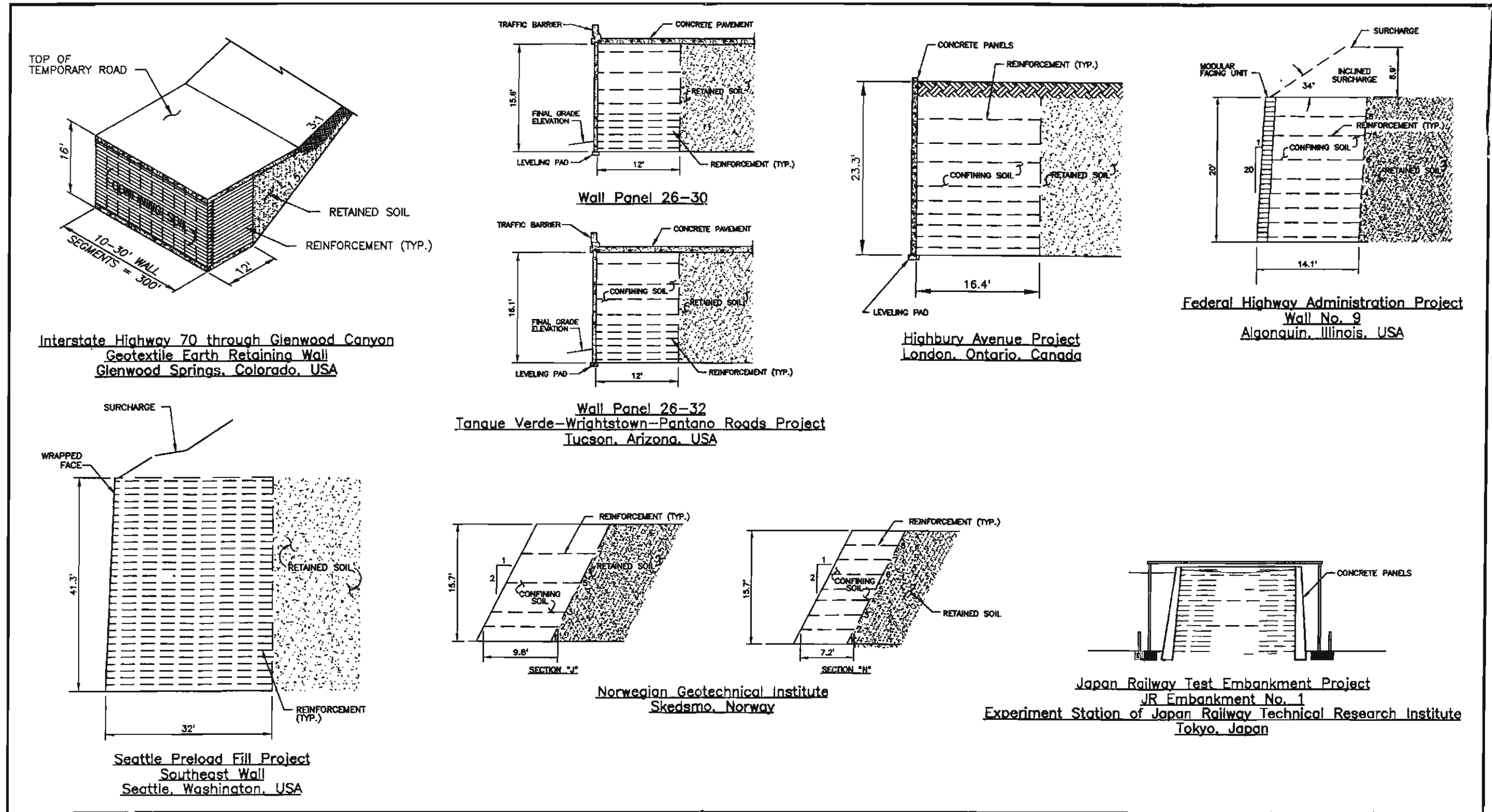

Figure 2.2
Wall Profiles for Selected GRS Retaining Wall Projects

In 1983 and 1993, samples of the reinforcement were exhumed to determine the survivability and durability of the reinforcement (Bell and Barrett, 1994). The strength of the exhumed reinforcement was compared with that of archive samples. The results of the test are described in Chapter 3. Additional project information can be found in Federal Highway Administration (FHWA) Report No. CHOH-DTP-R-86-16 entitled "Evaluation of Fabric Reinforced Earth Wall" (Derakhsandeh and Barrett, 1986).

2.1.2 Tanque Verde - Wrightstown - Pantano Roads Project

In 1984 and 1985, 46 GRS retaining walls were constructed in the city of Tucson as part of the Tanque Verde Grade Separation Project. In September of 1985 two of the walls were instrumented (Wall Panels 26-30 and 26-32) to monitor their performance during and after construction. Approximately seven years of performance data have been published for the two instrumented walls (Collin, Bright, and Berg, 1994). The original design and instrumentation information is contained in an Federal Highway Administration (FHWA) report entitled "Tensar Geogrid-Reinforced Soil Wall" (FHWA, 1989). Other papers have been written by Berg, Bonaparte, Anerson, and Chouery (1986) and Fishman, Desai, and Sogge (1993) describing the construction and performance of the walls.

The city of Tucson is located in the southern part of the state of Arizona, USA, in the Sonora desert where summer temperatures can reach as high as 111° Fahrenheit. Soil temperatures within the wall reached as high as 97° Fahrenheit. Elevated temperature environments for geosynthetics were a potential design concern since the high temperatures may accelerate mechanisms of degradation. Similar to the Colorado project, reinforcement samples were exhumed after 11 years of service to examine the durability of

the reinforcement (Bright, Collins and Berg, 1994) which is described in Chapter 3.

2.1.3 Norwegian Geotechnical Institute Project

In 1987, the Norwegian Geotechnical Institute (NGI) built a full-scale GRS retaining test wall in Skedsmo, Norway. The purpose of the wall was to establish characteristics of creep in the reinforcement. Skedsmo is located near the city of Oslo, Norway, in northern Europe. The climate at Oslo is moderate with temperatures ranging from 38° Fahrenheit in the winter to 64° Fahrenheit in the summer. Rainfall can be heavy at times with approximately 40 inches of rainfall annually.

The wall was instrumented in two sections, 'J' and 'N', each with a different arrangement and spacing of the reinforcement. Approximately four years of performance data have been published for the two instrumented sections (Fannin and Herman, 1992). Following construction, the wall was monitored for approximately four weeks under self-weight loading. Thereafter, the top of the wall was cyclically loaded by using water tanks that applied a maximum contact pressure of 6,000 lb/ft². After approximately two months of cyclic loading, the tanks were removed and a permanent 10-foot-high surcharge was placed on top of the wall applying a uniform and sustained pressure of 10,000 lb/ft².

The original design and instrumentation information are contained in the paper entitled "Geosynthetic Strength - Ultimate and Serviceability Limit State Design" by Fannin and Hermann (1992). An additional paper describing the project Fannin and Hermann, (1990) has also been published.

2.1.4 Japan Railway Test Embankment Project

Two test embankments were constructed at the Experiment Station of Japan Railway Technical Research Institute near Tokyo, Japan. The test embankments were part of a series of embankments constructed with sand and Tokyo's sensitive clays in the 1980s to develop an internal reinforcing system that could withstand its heavy precipitation events (Tatsuoka, Tateyama, Tamura, and Yamauchi). The first test embankment (JR Number 1) was backfilled with sand while the second embankment (JR Number 2) was backfilled with clay. JR Number 1 was selected for this study.

JR Number 1 was constructed in 1988 to evaluate the stability of GRS embankments with rigid facing. Instruments were installed during construction and monitored for approximately two years until 1990, when it was loaded to failure. The facing consisted of rigid cast-in-place concrete panels installed in five wall segments. One wall segment consisted of discrete panel squares for comparison with the rigid panels. The overall project information can be found in a paper written by Tatsuoka, Murata, and Tateyama (1992) entitled "Permanent Geosynthetic-Reinforced Soil Retaining Walls used for Railway Embankments in Japan".

2.1.5 Highbury Avenue Project

The Royal Military College of Canada has published several papers documenting the long-term performance of a GRS retaining wall used in reconstructing and widening Highbury Avenue in London, Ontario, Canada. The wall was instrumented during construction in late 1989. Approximately 2 years of performance data have been published through August of 1991 (Bathurst, 1992). The research objective for the project was to collect performance data from a well-instrumented in-service GRS retaining wall to

evaluate its long-term performance. Additional information can be found in the paper by Bathurst (1992) entitled "Case Study of a Monitored Propped Panel Wall".

2.1.6 Federal Highway Administration Research Project

From 1984 to 1989, the FHWA sponsored several soil reinforcement research projects at its stone quarry in Algonquin, Illinois, USA. One project consisted of building a wall referred to as "Wall 9". The wall was built to quantify the long-term behavior of continuous filament polyester geogrid reinforcement and dry-stacked, soil filled facing units (Simac, Christopher and Bonczkiewicz, 1990). The test wall was constructed with a very low factor of safety to evaluate the applicability of existing design methods. The internal stresses were monitored for three months, then an inclined surcharge approximately seven feet high was placed and monitored for approximately 1.3 years.

2.1.7 Seattle Preload Fill Project

In March of 1989, the Washington State Department of Transportation designed and supervised the construction of a series of GRS retaining walls to provide a preload fill in an area of limited right-of-way located in Seattle, Washington, USA. The tallest wall (southeast wall) constructed for the project had a height of 41.3 feet and supported 17.4 feet of surcharge fill. Since this wall was significantly higher than any previously constructed wall, instrumentation was installed to monitor its performance. The wall was monitored for approximately one year after which it was demolished. Specific design information can be found in the paper entitled "Performance of a 12.6 m High Geotextile Wall in Seattle, Washington" (Allen, Christopher, and Holtz, 1992).

2.2 Design Approach Evaluation

This section summarizes the approach used to design the GRS retaining walls selected for the study previously described. The purpose for evaluating the design approach is to illustrate how the current methodologies address design considerations such as external and internal stability, creep, construction damage, and biological degradation of the reinforcement. Each of these considerations add conservatism to the design. When the conservatism from each of these design considerations is combined, the GRS retaining wall design can be grossly overconservative.

2.2.1 External and Internal Stability

The design consideration for external stability is satisfied when there is an adequate safety margin for failure due to sliding, foundation bearing and overall slope failure. Similar to the design approach for conventional retaining walls, external stability is based on limit equilibrium analysis where destabilizing forces (e.g., lateral earth pressure) against the reinforced soil mass are resisted by stabilizing forces (e.g., reinforced soil mass weight and external forces) with adequate margins for safety. Internal stability is satisfied when the wall is sufficiently stable against failure within the reinforced soil mass. External stability design methods are well understood and are therefore not addressed in this study. However, internal stability design methods for GRS retaining walls have not been well-established and can vary from one design to another.

The retaining walls selected for this study were designed using a commonly used design approach. In general, the internal stability of the selected walls was satisfied using an ultimate-strength approach based on the method of limit equilibrium. The ultimate-strength approach applies

factors of safety to the ultimate strength of the materials (i.e., soil, reinforcement and facing) or to the computed quantities (i.e., forces and moments) or to both the ultimate strength and calculated quantities (Wu, 1994b). The specific quantities and strength parameters include:

- Lateral forces from the surcharge, reinforced soil mass and retained soil;
- Reinforcement tensile strength; and
- Facing rigidity.

Due to the lack of reliable empirical data, somewhat arbitrary factors of safety are used, which have resulted in overconservative designs. The following subsections describe how the quantities, strength parameters and associated factors of safety were determined for each project.

2.2.2 Lateral Forces

Lateral forces on a GRS retaining wall can be described by two important characteristics. The first characteristic is the location of the failure surface. The second is the lateral earth pressure distribution providing the driving forces. As mentioned previously, these two characteristics are being studied by others.

In general, the retaining wall designs in the selected projects assumed a Rankine planar failure surface through the reinforced mass. The part of the reinforcement that extends beyond the assumed failure wedge is considered to be tension-resistant tiebacks (frequently referred to as the tie-back wedge method) as illustrated on Figure 2.3. The tie-back wedge method of analysis assumes that the shear strength of the reinforced soil mass behind the wall is fully mobilized and thus active lateral earth pressures are developed.

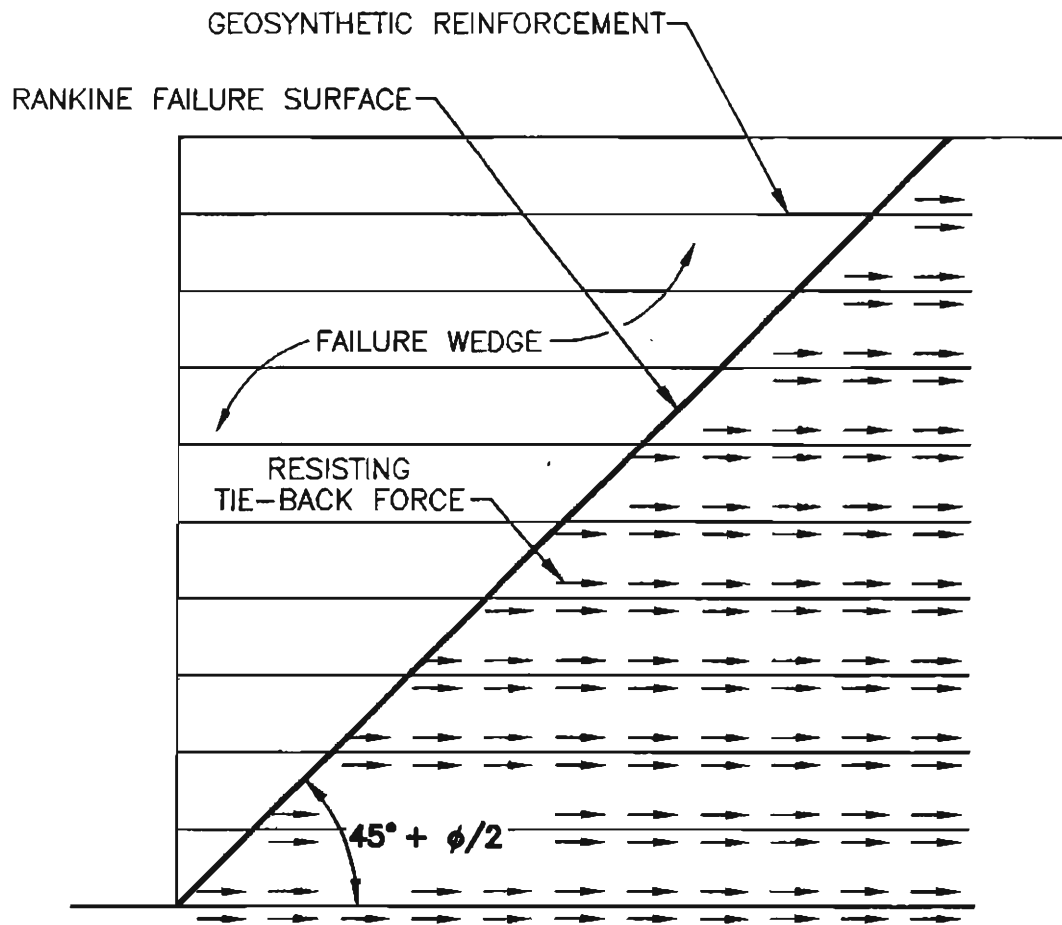

Figure 2.3
Forces Using the Tie-Back Wedge Method

The second characteristic is the assumed lateral earth pressure distribution. Typical lateral earth pressure distributions such as the linear Rankine surface typically overestimate the lateral force on the reinforced soil mass adding conservatism to the designs. Claybourn and Wu (1993) compared six design methods and revealed that there are very significant discrepancies in the factors of safety for various design methods due to varying earth pressure distributions. In a typical wall examined in that study, the combined factors of safety ranged from 3 to 23, depending on the earth pressure distribution used. Typically, a linear Rankine lateral earth pressure distribution was assumed for the selected projects. In most cases an active condition was assumed. However, the Interstate Highway 70 through Glenwood Canyon project design assumed "at rest" conditions.

2.2.3 Reinforcement Tensile Strength

In the tie-back wedge method of analysis, the lateral earth pressures are resisted by the tensile strength of the reinforcement. This is the design component that is adjusted to account for creep since geosynthetics are comprised of creep-sensitive polymers. The adjustments include reducing the short-term tensile strength to account for creep and then further reductions to account for construction damage and biological degradation. The strength, adjusted for creep, is referred to as the creep-limited strength. The creep-limited strength adjusted for construction damage and biological degradation is referred to as the design-strength. The short-term, creep-limited, and design tensile strengths for the types of reinforcement used in the selected projects are summarized in Table 2.2. Each type of reinforcement strength is described in the following subsections

**Table 2.2
Reinforcement Tensile Strength in Selected Projects**

Project	Wall Name	Height (ft)	Number of Reinforcement Layers	Average Reinforcement Spacing (ft)	Short-Term Strength (lb/ft)	Creep Reduction Coefficient (%)	Creep-Limited Strength (lb/ft)	Design-Strength (lb/ft)
Interstate Highway 70 through Glenwood Canyon	Geotextile Earth Retaining Wall	16	17	0.9	400-1150	40 to 55	220 to 340	220 to 340
Tanque Verde-Wrightstown-Pantano Roads	Wall Panel 26-30	15.6	10	1.6	5400	37	1933	1327
	Wall Panel 26-32	16.1	10	1.6	5400	37	1933	1327
Norwegian Geotechnical Institute	Wall Section J	15.7	4	2.2	833-3600	NA	NA	833-3600
	Wall Section N	15.7	8	2	833-3600	NA	NA	833-3600
Japan Railway Test Embankment	JR Embankment No. 1	16.4	17	1	1880	NA	NA	1880
Highbury Avenue	Highbury Ave. Wall	23.3	9	0.4	2000-3450	NA	NA	2000-3450
Federal Highway Administration	Wall No. 9	20	8	2.5	2604	60	1560	1032
Seattle Preload Fill	Southeast Wall	41.3	33	1.25	2066-12400	40-59	689-6097	689-6097

NA = Not available in the literature

2.2.3.1 Short-Term Strength

The short-term tensile strength of the geosynthetic reinforcement is determined by applying a tensile load to an unconfined or confined test sample at a constant strain-rate until failure occurs. During the loading process, both load and displacement are measured to obtain a stress-strain curve as illustrated on Figure 2.4.

The maximum tensile stress is typically referred to as the ultimate stress or short-term stress. The strain at failure is typically referred to as the maximum strain. Stress is typically measured in load per unit width and the strain is computed by dividing the elongation by the original specimen length. These values are illustrated on a typical stress-strain curve on Figure 2.4.

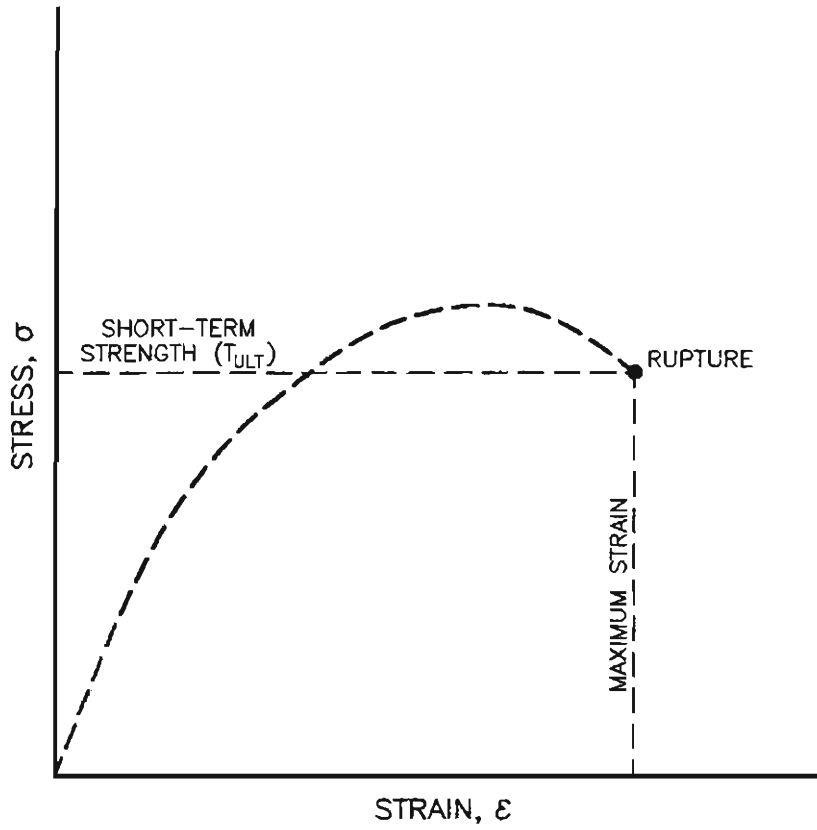

Figure 2.4
Parameters of a Geosynthetic Stress-Strain Curve

The American Society for Testing and Materials (ASTM) recently standardized the procedure for determining the unconfined short-term strength and maximum elongation for geosynthetics which is described in ASTM Test Method D 4595, "Tensile Properties of Geotextiles by the Wide Width Strip Method". The ASTM D 4595 wide-width test uses a geosynthetic sample that is 8 inches in width and 4 inches in gage length. The sample is stressed uniaxially at a constant strain rate of 10 percent per minute until failure occurs. The short-term strengths for the reinforcement used for the Interstate Highway 70 through Glenwood Canyon, Norwegian Geotechnical Institute, FHWA and Seattle Preload Fill Projects were determined by this method.

The short-term strength for the Tanque Verde - Wrightstown - Pantano Roads Project was determined using a four-inch-wide sample stressed uniaxially at a constant rate of 2 percent per minute. The test method for the short-term strength of the reinforcement used in the remaining two projects (the Highbury Avenue and Japan Railway Test Embankment projects) were not available in the literature. The smaller width sample used for the Tanque Verde - Wrightstown - Pantano Roads project most likely produced a weaker load-displacement response of the sample due to the Poisson effect (Wu and Tatsuka, 1992) therefore adding conservatism to the design.

2.2.3.2 Creep-limited Strength

The creep-limited strength values reported in the literature for the selected projects are listed in Table 2.2. The CRC for the projects that reported it in the literature are also listed. The CRC is computed using the creep-limited strength and short-term strength as illustrated in Equation 2.1.

$$\text{CRC} = T_{\text{creep}}/T_{\text{ult}} \quad \text{Equation 2.1}$$

Where: CRC = Creep reduction coefficient

T_{creep} = Tensile strength accounting for creep

T_{ult} = Short-term strength

As shown in Table 2.2, the CRC values used for the selected projects range from 40 to 65 percent. For comparison, The AASHTO-AGC-ARTBA Joint Committee Task Force 27 (AASHTO, 1990) recommends the following CRC values for different polymer-type materials:

<u>Polymer Type</u>	<u>Creep Reduction Coefficient</u>
Polyester	40%
Polypropylene	20%
Polyamide	35%
Polyethylene	20%

For example, the creep-limited strength for a reinforcement with a short-term strength of 1,000 lb/ft would be 200 lb/ft using a CRC of 20 percent. The reinforcement materials used for the selected projects were manufactured from polypropylene and polyester polymers. Although the CRC values used in the selected projects were higher than the recommended values (i.e., less conservative) the reinforcements exhibited very small strains over extended periods of time as will be discussed in Chapter 3.

The creep-limited strength for the Tanque Verde - Wrightstown - Pantano Roads project was determined by McGown (1984). Rapid creep tests were performed to determine the creep-limited strength for the geogrid reinforcement used in the project. These tests consisted of developing isochronous load-strain curves at varying temperatures, strain rates and loads to determine a load below which rupture by a ductile yield was not likely to occur. Isochronous curves can be used to determine the load in a geosynthetic for a certain strain at a given time. The other projects arbitrarily selected various creep reduction coefficients to account for creep instead of performing actual element tests.

The current AASHTO design procedure recommends determining the creep-limited strength by the following method. Controlled laboratory creep tests are performed for a minimum duration of 10,000 hours for a range of load levels on reinforcement samples. The samples are then tested in the expected loading direction, in either a confined or unconfined mode, and at an assumed in-ground temperature of 70° Fahrenheit. The test results are then extrapolated to the required design life using the procedure outlined in ASTM D 2837. From the creep test, two tensile loads should be determined: the limit state tensile load (T_{limit}), and the serviceability state tensile load ($T_{service}$). The limit state tensile load is defined as the highest load level at which the log time creep-strain rate continues to decrease with time within the design lifetime without inducing either brittle or ductile failure. The serviceability state tensile load is defined as the load level at which total strain will not exceed 5 percent within the design lifetime. The design lifetime is typically 75 years. AASHTO recommends that critical walls be designed for a 100-year lifespan (AASHTO, 1990).

Since these creep tests take an extended amount of time, the majority of designers used the recommended default values listed above in Section 2.2.3.2. Using default CRC value results in using only 20 to 40 percent of the reinforcement's short-term strength. Moreover, partial factors of safety for construction damage, durability, and overall internal stability further reduce the creep-limited strength to obtain the design-strength as described below.

2.2.3.3 Design Strength

The design strengths reported in the literature for the selected projects are listed in Table 2.2. The design strength is the tensile strength of the reinforcement used for design purposes. Most design methods use a partial factor of safety approach to compute the design strength where the creep-limited strength (i.e., T_{limit} and/or $T_{service}$) is adjusted to account for site-specific conditions. The AASHTO-AGC-ARTBA Joint Committee Task Force 27 currently recommends the following procedure using the partial factors of safety to compute the design strength.

1. Compute the allowable long-term reinforcement tension based on a limit state criterion given by:

$$T_{al} = T_{limit} / FD * FC * FS$$

Where: T_{al} = Allowable long-term tension based on a limit state criterion

T_{limit} = Creep-limited strength based on a limit state

FD = Partial factor of safety for polymer durability

FC = Partial factor of safety for construction damage

FS = Overall factor of safety to account for uncertainties in structure geometry, fill properties, reinforcement properties and externally applied loads

2. Compute the allowable long-term reinforcement tension based on serviceability state criterion given by:

$$T_{as} = T_{service}/FC*FD$$

Where: T_{as} = Allowable long-term tension based on serviceability criterion

$T_{service}$ = The allowable long-term tension based on a serviceability state

3. The design strength should be the lesser of T_{df} and T_{as} .

The partial factor of safety for durability accounts for the degradation of the geosynthetic reinforcement due to chemical and biological exposure. In the absence of product-specific durability information, AASHTO recommends that the FD should be between 1.10 and 2.0. The partial factor of safety for construction damage accounts for damage (i.e., rips, punctures) to the reinforcement during wall construction. In the absence of full-scale construction damage tests, AASHTO recommends that the FC should be between 1.25 and 3.0. For permanent, vertically faced GRS retaining walls the minimum overall factor of safety should be no less than 1.5 (AASHTO, 1990). The partial factors of safety used in the selected projects are described below.

2.2.4 Partial Factors of Safety

2.2.4.1 Factor of Safety for Durability

None of the selected projects directly used a factor of safety for durability. However, reinforcement samples were exhumed from the walls built for the Interstate Highway 70 through Glenwood Canyon and the Tanque Verde - Wrightstown - Pantano Roads projects located in Colorado and Arizona respectively. Reinforcement samples were exhumed

approximately 11 years and 8 years after construction for the Colorado and Arizona projects, respectively. After the samples were exhumed, they were tested to determine their tensile strength and compared with the tensile strength of archived samples cut from the same reinforcement material lots used in construction. The Colorado project used a non-woven geotextile reinforcement manufactured from polypropylene and polyester polymers, while the Arizona project used a geogrid reinforcement manufactured from a polypropylene polymer.

The results from the durability testing indicate that the geosynthetic material degrades very little over time in normal soil conditions. In both projects, no significant decrease in tensile strength was observed in the exhumed samples (Bright et al., 1994; and Bell and Barrett, 1994). For comparison, the current factor of safety recommended by the Task Force 27 report (e.g., 1.10 to 2.0) reduces the creep-limited tensile strength of the reinforcement by 10 to 50 percent.

2.2.4.2 Factor of Safety for Construction Damage

Similar to the factor of safety for durability (FD), the factor of safety for construction damage (FC) was left out of the design computations for the selected projects. The reinforcement samples exhumed from the Colorado project exhibited an average 27 percent loss of strength based on element tensile strength due to construction damage (Bell and Barrett, 1994) even though the wall performed very well.

Similar to element tests for creep, the reduction in the element strength due to construction damage represents only the behavior of the reinforcement alone without accounting for the confinement of the reinforced soil and soil/reinforcement interaction. Recently, San and Matsui

(San and Matsui (____)) performed a test on a 20-foot-high wall where the reinforcement embedded in the wall was cut using electrical wiring. The reinforcement was cut at varying lengths starting from a distance furthest from the face and progressing to the face of the wall. Each time the reinforcement was cut, lateral and vertical displacements and reinforcement strains were measured. After all the reinforcement layers had been cut within approximately 1.5 feet behind the face, the total lateral displacement was only approximately 1.5 inches. Based on the tie-back wedge design concept, the wall should have collapsed once the reinforcement was cut inside the Rankine failure surface. This test provides an excellent illustration of the fact that neither construction damage or degradation of geosynthetics will hinder its reinforcing function. Cutting the geosynthetic reinforcement into small segments following construction can be considered an extreme form of construction damage and biological/chemical degradation. Apparently, whether the reinforcement is continuous or not has little effect on the function of the reinforcement to restrain lateral deformation of the soil.

The test performed by San and Matsui can provide reasons for the good performance of GRS retaining walls even with construction damage like in the Colorado project. From the test results and performance of the selected case studies, two conclusions regarding the factor of safety for construction damage can be made:

- Element tensile strength tests on exhumed reinforcement does not characterize the impact to a GRS retaining wall due to construction damage; and
- The recommended construction damage factors of safety (i.e., 1.25 to 3.0) are overconservative.

2.2.4.3 Overall Factor of Safety

The Seattle Preload Fill located in Washington, USA and the Tanque Verde - Wrightstown - Pantano Roads Project located in Arizona, USA, used overall factors of safety of 1.2 and 1.5 respectively in their designs. In both cases, the walls performed very well. Since soil properties can vary, a recommended overall factor of safety of 1.5 may be reasonable in GRS retaining wall designs. By using a factor of safety of 1.5, the reinforcement design strength is computed by reducing the short-term tensile strength by 33 percent.

2.2.5 Facing Rigidity

By placing geosynthetic reinforcing in the soil, the strength of the soil is improved such that the vertical face of the soil/geosynthetic composite is self-supporting; therefore, most designs ignore the resistance of the facing. However, most GRS walls use facing for aesthetic purposes and to prevent raveling between the reinforcing elements. Most types of facing include concrete modular blocks that are dry stacked in front of the wall. Other types of facing materials include rigid concrete panels and wrapped geosynthetics. The Seattle Preload Fill, Interstate Highway 70 through Glenwood Canyon and Norwegian Geotechnical Institute projects used a wrapped geotextile face as illustrated on Figure 2.2. and in the project photographs in Appendix A. Shotcrete was placed on the Glenwood Canyon project wall to prevent ultraviolet degradation of the geotextile. Modular block type facing was used for the FHWA research project illustrated on Figure 2.2 and in the project photographs in Appendix A.

The Japan Railway Embankment, Tanque Verde - Wrightstown - Pantano Roads and Highbury Avenue projects used rigid concrete panels. In the latter two projects, the facing was mechanically attached to the

reinforcement. For these two projects, the reinforcement strains were highest at the face than at other locations along the reinforcement. This is due to larger settlement of the reinforced fill relative to the rigid facing (Bright, 1994; and Bathurst, 1992). The Japan Railway project used a flexible concrete panel on the middle section of the wall to compare the wall's performance using rigid and flexible facing material. The portion with the flexible facing exhibited much larger deformation than the rigid facing (Tatsuoka, 1992).

3. Project Long-Term Performance

This chapter summarizes the performance of the GRS retaining walls selected from the literature review and survey. The following section describes the instrumentation and measured parameters used to quantify the long-term performance of the walls. Section 3.2 provides the overall performance of the walls including the reinforcement strains and wall movements. Section 3.3 describes a conservatism index (CI) that was developed to quantify the conservativeness of the designs used in the selected projects. Section 3.3.1 describes the creep modulus developed to quantify the rate of creep.

3.1 Instrumentation and Measured Parameters

For each of the selected projects, instruments were installed during construction to quantify the behavior of GRS retaining walls in field conditions. The long-term performance was quantified by recording instrument readings periodically over an extended period of time and documenting the results in published papers. Specific behavior parameters were monitored for each project depending on the project's objectives as described in Chapter 2. In general, the behavior parameters listed below were measured:

- Horizontal and vertical displacements of the reinforced soil mass;
- Reinforcement strains in selected layers and locations; and
- External and internal soil temperatures.

Strain gauges were installed on selected layers of reinforcement at varying distances from the face of the wall. The primary objective in most of the projects was to determine the location of the maximum strain in the reinforcement. This would confirm the theoretical location of the failure

surface assumed for design. The second objective was to measure the magnitude of strain in the reinforcement during and after-construction. The location and type of instrumentation used for each project are illustrated on the project description sheets provided in Appendix A.

3.2 Reinforcement Strains and Wall Movement

The maximum reinforcement creep strain and wall movements for each project are listed in Table 3.1. If the creep strain was unavailable in the literature for a particular project, it was computed based on the incremental change in total strain. Note, that the creep strain listed in Table 3.1 refers to the deformation of the wall due to creep occurring after construction. The movement listed in Table 3.1 refers to the total displacement of wall since the beginning of construction. In some cases, the majority of the movement was during construction. The CRC used for the design and recommended by AASHTO for each project is also listed.

3.2.1 Interstate Highway 70 through Glenwood Canyon Project

The Interstate Highway 70 through Glenwood Canyon project was purposely designed to determine the lower stability limits by designing at or near the equilibrium factor of safety. It was anticipated that the reinforcement would exhibit excessive strains on the order of 55 percent, yet little movement within the reinforced soil mass was observed. Approximately one year after the wall was constructed, a surcharge load was applied to the top in an attempt to create failure conditions. The surcharge consisted of a 15 foot high soil embankment applying a pressure of approximately 1,950 lb/ft². However, failure never occurred.

The wall was constructed on a weak foundation soil and experienced significant movement. The retaining wall experienced over two feet of differential settlement from one end of the wall to the other due to

consolidation of underlying clays. Despite the large differential settlements, only small strains occurred in the reinforcement (Derakhashandeh and Barrett, 1986).

The CRC values used in the design of the wall ranged from 40 to 55 percent for reinforcement layers manufactured from polypropylene type polymers and 65 percent for the reinforcement layers manufactured from polyester type polymers. AASHTO recommends CRC values of 20 and 40 percent for polypropylene and polyester respectively (AASHTO, 1990). The CRC values used for the design are over two and one and half times less conservative for the polypropylene and polyester reinforcement layers respectively, yet the wall performed very well.

Since the wall performed better than anticipated, the researchers concluded that the mechanisms of geosynthetic reinforcement soil are not well understood and the ability to select allowable loads is limited (Bell, 1983). They also concluded that more full-scale walls should be instrumented and monitored to better understand the behavior of the soil/geosynthetic interaction.

Table 3.1
CRC, Reinforcement Strain and Wall Movement for the Selected Projects

Project	Wall Name	H (ft)	t (years)	s _{avg} (ft)	CRC Design (%)	CRC AASHTO (%)	ε _{cmax} (%)	Movement	
								Y _{max} (in)	X _{max} (in)
Interstate Highway 70 through Glenwood Canyon	Geotextile Earth Retaining Wall	16	0.8	0.9	40-55	20-40	NA	3.5	5.15
Tanque Verde-Wrightstown-Pantano Roads	Wall Panel 26-30	15.6	7	1.6	37	20	<1	NA	3.7
	Wall Panel 26-32	16.1	7	1.6	37	20	<1	NA	3.7
Norwegian Geotechnical Institute	Wall Section J	15.7	4	2.2	NA	20	0.5	NA	NA
	Wall Section N	15.7	4	2	NA	20	0.6	NA	NA
Japan Railway Test Embankment	JR Embankment No. 1	16.4	2	1	NA	40	NA	1	-0.4
Highbury Avenue	Highbury Ave. Wall	23.3	2	0.4	NA	20	1.5	NA	1.7
Federal Highway Administration	Wall No. 9	20	1.3	2.5	60	40	0.7	NA	~2
Seattle Preload Fill	Southeast Wall	41.3	1	1.25	40-60	20-40	0.7	1.4 to 1.6	5.5-6.3

Legend

NA = Not available in the literature

H = Height

t = Monitoring duration

s_{avg} = Average reinforcement spacing

CRC Design = Creep reduction coefficient used in the design

CRC AASHTO = Creep reduction coefficient recommended by AASHTO

ε_{cmax} = Maximum creep strain in the reinforcement

Y_{max} = Total vertical movement of the wall

X_{max} = Total horizontal movement

3.2.2 Tanque Verde - Wrightstown - Pantano Roads Project

The performance of Wall Panels 26-30 and 26-32 was monitored for approximately seven years after construction. Geogrid reinforcement strains were measured in the bottom, middle and top layers of the two wall panels using resistance strain gages and inductance coils. Strain readings from the inductance coils had a large variance due to low strains in the reinforcement, therefore the results were believed to be unreliable (FHWA, 1989) so the readings from the strain gauges are reported in this study.

Reinforcement strains were measured during construction, two weeks after construction and thereafter on an annual basis. The post-construction strain measurements were adjusted to account prefensioning and compaction during construction so that strains measured after construction would be the result of creep.

The lateral movement of the wall was measured by surveying points at the top of the wall. The points were surveyed during construction and up to one month after construction. During construction, the top of the both walls moved laterally approximately three inches while the bottom of the wall remained stationary. Little movement was observed after construction.

The mean total creep strain in the reinforcement after construction is illustrated on Figure 3.1. As illustrated on Figure 3.1, the strain increased in the reinforcement during the first year of service indicating that creep was occurring. Thereafter, however, the creep strain remained generally constant indicating that the wall had stabilized with time. The maximum creep strain recorded was less than 1.0 percent. Based on isochronous load-strain curves developed by McGown (1984), the load induced in the

reinforcement at 1.0 percent strain was approximately 265 lb/ft. This is approximately only 5 percent of the short-term strength (5,400 lb/ft).

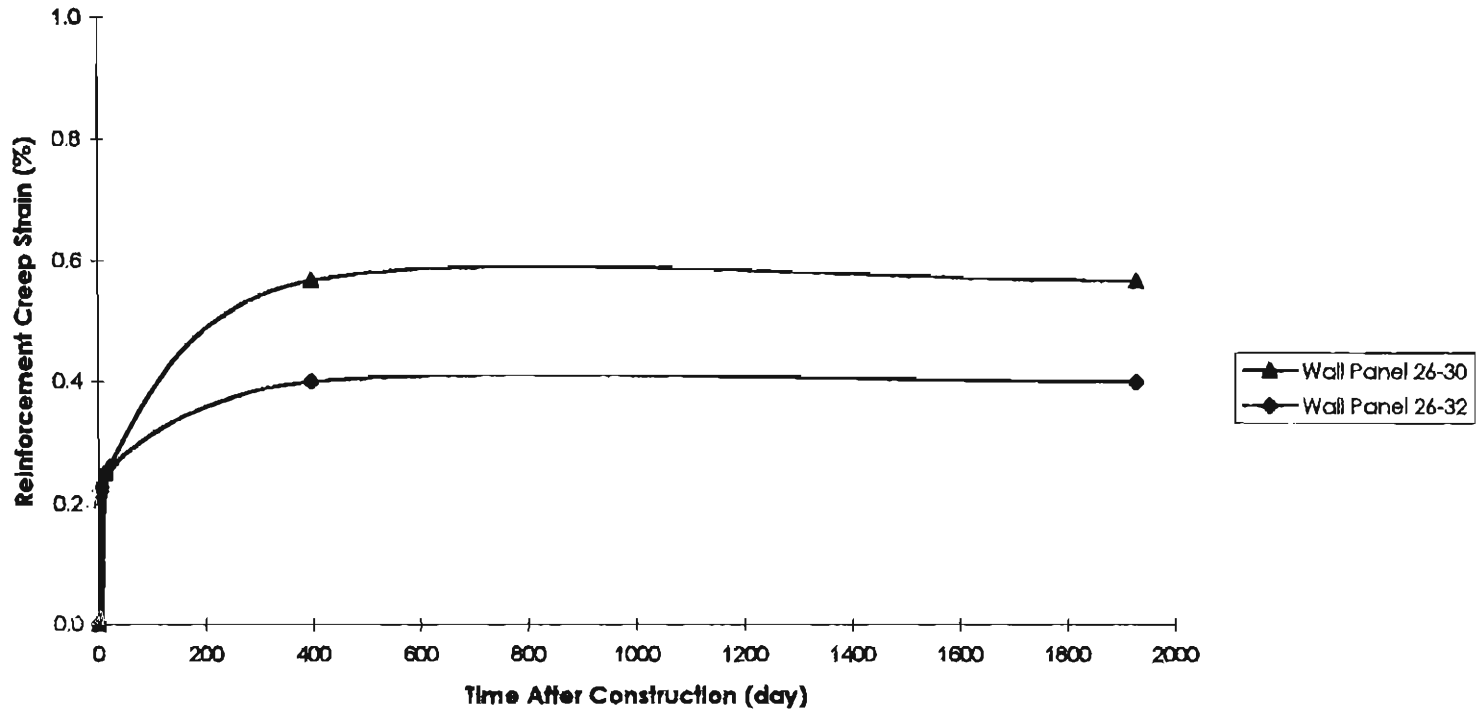

Figure 3.1
Reinforcement Creep-Time Curves for the Tanque Verde - Wrightstown - Pantano Roads Project

3.2.3 Norwegian Geotechnical Institute Project

The performance of the Norwegian Geotechnical Institute project wall sections 'J' and 'N' was monitored for approximately four years since its construction. Both the force and strain was measured in the reinforcement. Section 'N' had twice as many layers of reinforcement than Section 'J'. Following construction, the wall was monitored for approximately four weeks under self-weight loading. Thereafter, the top of the wall was cyclically loaded for two months followed by a permanent surcharge.

The mean total creep strain in the reinforcement for the two sections following application of the permanent surcharge loading is illustrated on Figure 3.2. The creep strain was determined from the incremental increase in the total strain beginning 10 days after the surcharge was placed. The maximum strain over the four years was approximately 0.5 and 0.6 percent in section 'J' and 'N' respectively. The maximum tensile force in the reinforcement after the permanent surcharge reported in the literature was approximately 200 lb/ft for both of the sections. This is approximately 6 percent of the short-term strength (3,600 lb/ft). The CRC value used in the design for this project was unavailable in the literature. The CRC value recommended by AASHTO for the reinforcement type used in the two sections is 20 percent (AASHTO, 1990).

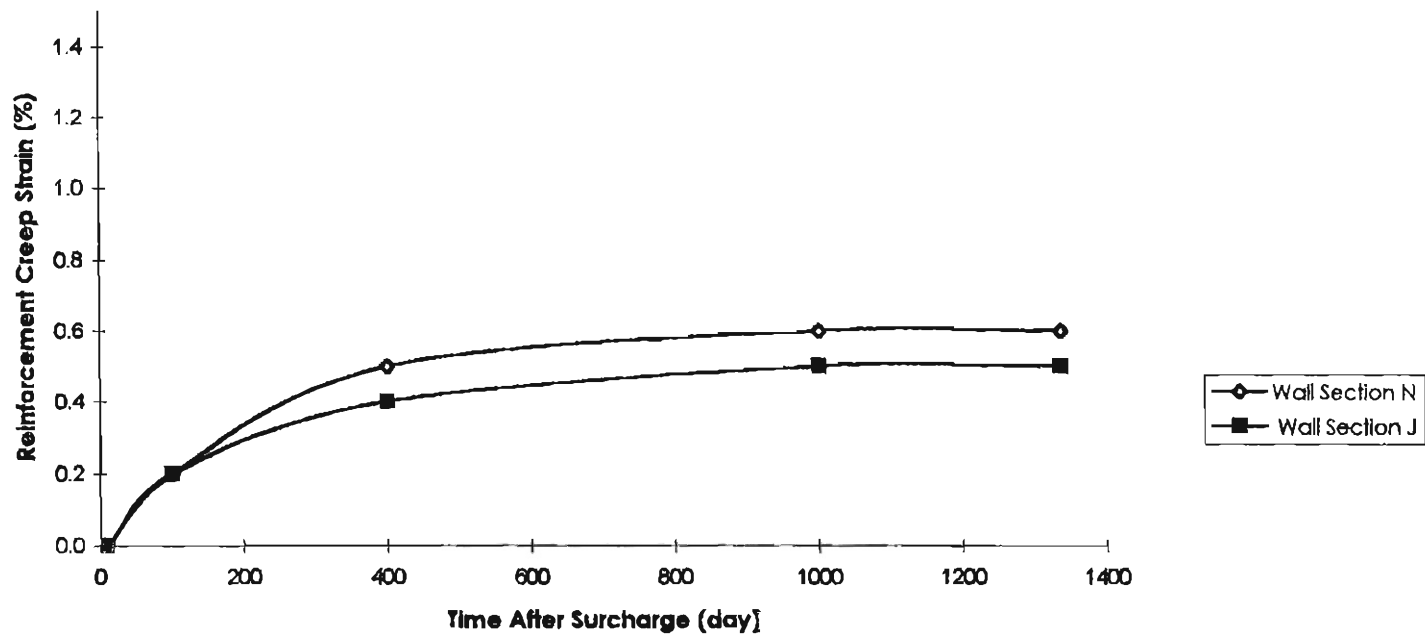
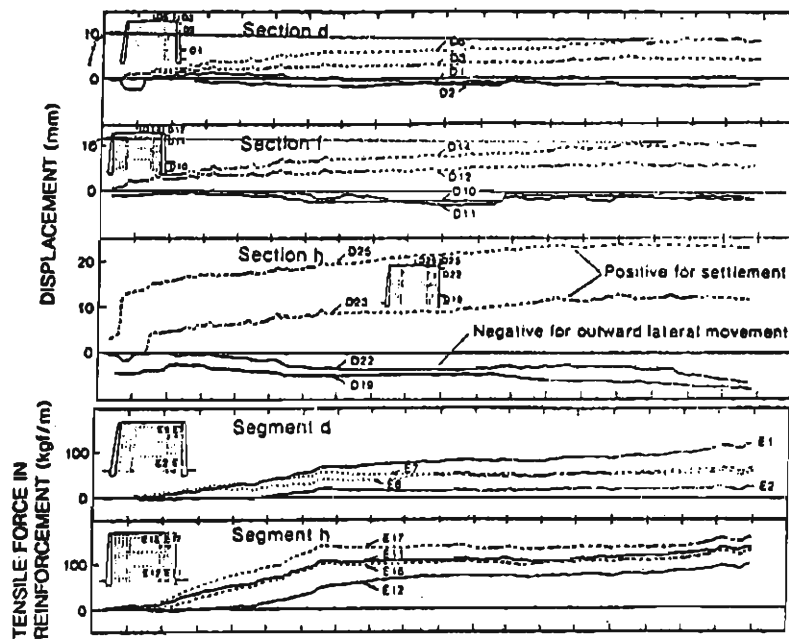

Figure 3.2
Reinforcement Creep-Time Curves for the Norwegian Geotechnical Institute Project

3.2.4 Japan Railway Test Embankment Project

The performance of the Japan Railway Test Embankment JR Number 1 was monitored approximately two years since its construction. The vertical and lateral displacement and tensile force in the reinforcement was measured in three wall sections (cross sections D-D, F-F, and H-H) illustrated on the project description sheets in Appendix A. Figure 3.3 illustrates the monitoring results.

As illustrated on Figure 3.3, the tensile force in the reinforcement increased during the first eight months reaching a nearly asymptotic state similar to the performance of the other projects. The maximum tensile force in the reinforcement was approximately 131 lb/ft. This is approximately only 7 percent of the short-term strength (1,880 lb/ft). The CRC value used in the design for this project was unavailable in the literature. The CRC value recommended by AASHTO for the reinforcement type used in the two sections is 40 percent (AASHTO, 1990).



Note: See Appendix A for Section locations

Figure 3.3
Tensile Force in Reinforcement and Displacement of the
Japan Railway Test Embankment Project
 (after Tatsuoka F., Murato O. and Tateyama M., 1992)

3.2.5 Highbury Avenue Project

The Highbury Avenue Wall was monitored for approximately two years. Reinforcement strain was measured after the props holding the concrete panels were removed. Reinforcement strain was measured thereafter in December 1990; then in March 1990; July and August 1990; and a year later in August 1991. The creep strain was based on the incremental change in the strain since December 1990. The maximum reinforcement creep strain was approximately 1.5 percent based on the mean creep strain. The mean creep strain over time is illustrated on Figure 3.4. Similar to the previous projects, the wall exhibited creep over the monitoring period, however, had begun to stabilize with time. The CRC value used for the project was unavailable in the literature.

3.2.6 Federal Highway Administration Research Project

Wall nine built for the FHWA project was monitored for approximately one year. Reinforcement strain and total wall movement was recorded more frequent than the previous projects. Instrument readings were recorded on an almost daily basis during construction and during placement of the surcharge load. The surcharge was completed November 10, 1989. Thereafter instrument readings were recorded nine times up through November 11, 1990.

The maximum creep strain computed after the surcharge load was placed is illustrated on Figure 3.5. The creep strain was based on the increment increase in total strain. As illustrated on Figure 3.5, the creep strain shows that the wall was becoming stable with time. The maximum creep strain was approximately .7 percent over the one year monitoring period. The total lateral movement after the props were released was

approximately 3.6 inches. The measurement was based on the vertical inclinometer directly behind the face of the wall. Most of the movement is most likely due to the tensioning of the reinforcement.

The CRC value used for the design was 60 percent. AASHTO recommends a more conservative CRC of 40 percent for the type of reinforcement used in wall nine. Although the CRC value used in the design was one and half times higher (e.g., less conservative), the reinforcement strains were very small.

3.2.7 Seattle Preload Fill Project

The southeast wall for the Seattle Preload Fill project was monitored for approximately one year after its construction. Similar to the FHWA wall, instrument readings were recorded on a frequent basis. The maximum reinforcement creep strain in the reinforcement over time is illustrated on Figure 3.6. Creep strain was determined immediately after the surcharge was placed on the wall. As illustrated on Figure 3.6, creep was occurring and beginning to stabilize. The maximum creep strain recorded in the reinforcement was less than 0.5 percent.

The CRC values used for the design were 40 and 60 percent for polypropylene and polyester type reinforcement respectively. AASHTO recommends CRC values of 20 and 40 percent for polypropylene and polyester respectively. The CRC values used were two and one and half times less conservative than the recommended values, yet very little strain was observed in the reinforcement.

The researchers concluded that the low strain were the result of lower than expected load level in the reinforcement or due to poorly understood interaction between the reinforcement and the confining soil. Additionally,

the reinforcement was damaged during construction damage with no apparent impact to the performance.

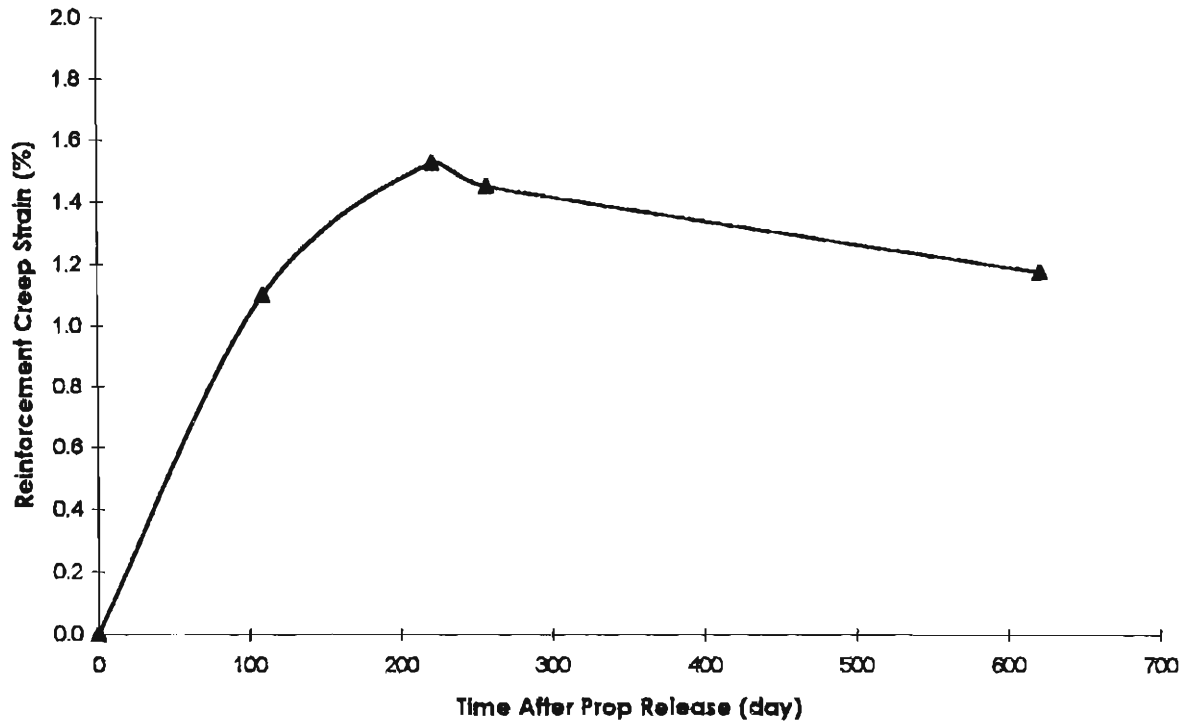

Figure 3.4
Reinforcement Creep-Time Curve for the Highbury Avenue Project

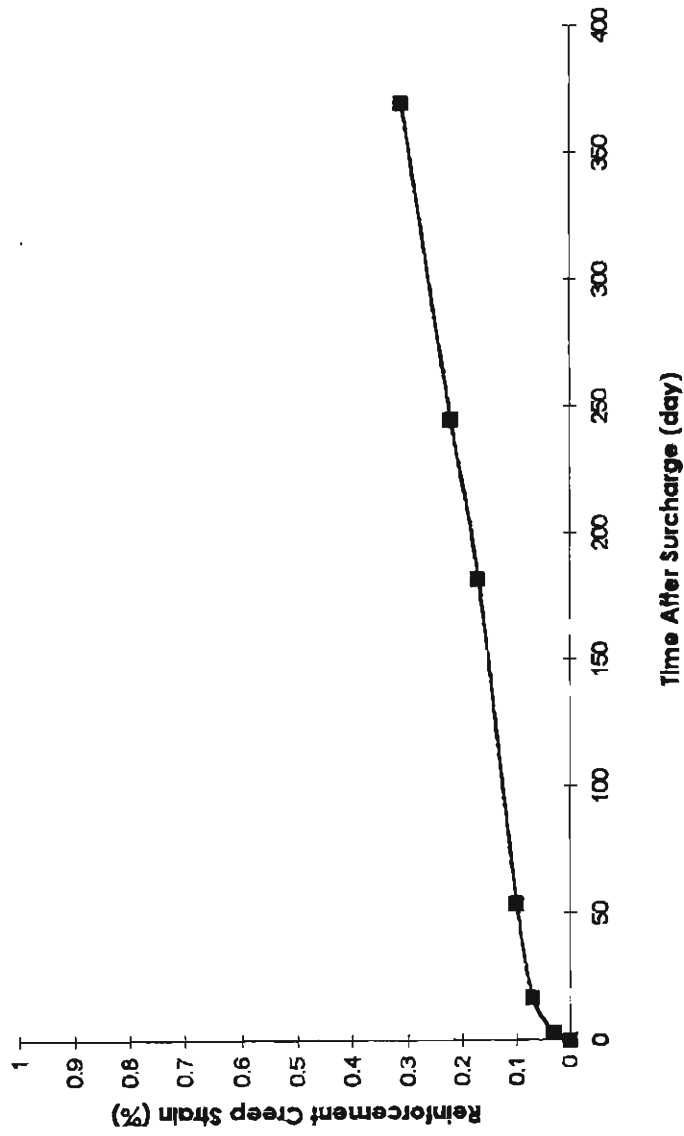

Figure 3.5
Reinforcement Creep-Time Curve for the FHWA Project

50

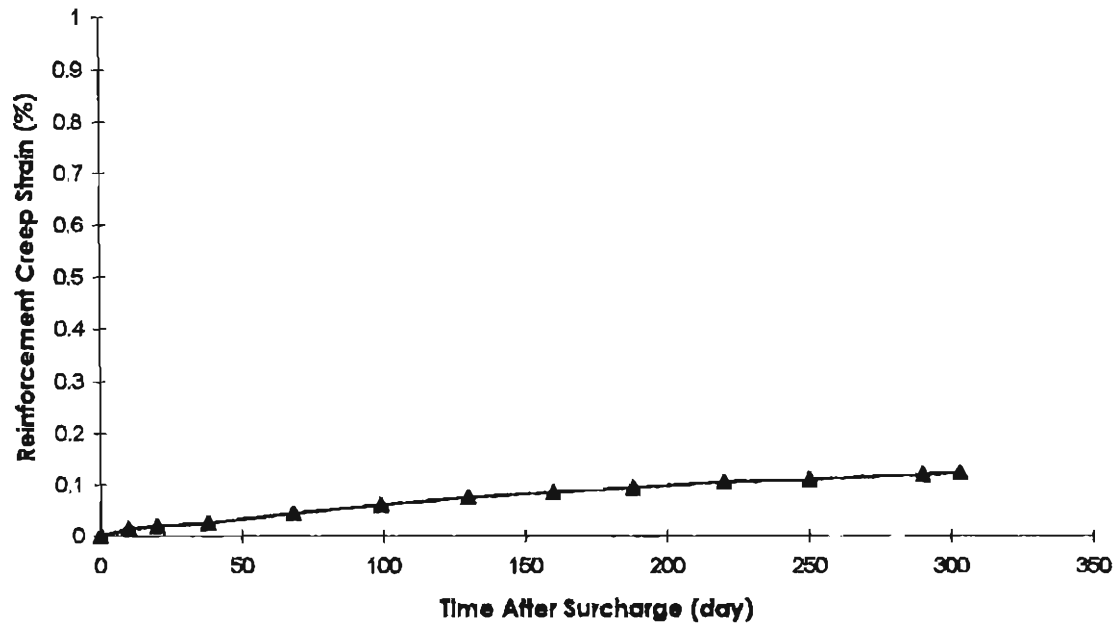

Figure 3.6
Reinforcement Creep-Time Curve for the Seattle Preload Project

3.3 Conservatism Index

The selected GRS retaining walls vary from conservative to less conservative designs. For example, the Interstate Highway 70 through Glenwood Canyon and Section 'J' of the Norwegian Geotechnical Institute projects were purposely designed to determine the lower stability limits by designing at, near equilibrium or even below factors of safety. Conversely, the Highbury Avenue and Tanque Verde - Wrightstown - Pantano Roads projects were designed using more conservative assumptions.

Due to the variability in retaining wall designs, direct comparison of the selected projects would be misleading. Therefore, a conservatism index (CI) was developed so that the design of the walls could be evaluated. In general, the CI value is computed using a limit equilibrium analysis where resisting lateral force provided by tensile strength of the reinforcement is divided by the driving lateral force of the earth. The CI value is based on the same principles of limit equilibrium used in the current design methods where the resisting tensile force is entirely provided by the reinforcement and redistribution of stresses due to the soil/geosynthetic interaction are ignored. The CI value takes into consideration the reinforcement strength, number of reinforcement layers, and active lateral earth pressure caused by the retained soil and surcharge. These parameters and the resulting CI for each project is listed in Table 3.2. Detailed computations are provided in Appendix B.

Table 3.2
Parameters Used to Compute the Conservatism Index

Project	Wall Name	Height (ft)	n	s_{avg} (ft)	ϕ (deg)	γ lb/ft ³	q lb/ft ²	Ka	CI
Interstate Highway 70 through Glenwood Canyon	Geotextile Earth Retaining Wall	16	17	0.9	35	130	1950	0.27	0.44
Tanque Verde-Wrightstown-Pantano Roads	Wall Panel 26-30	15.6	10	1.6	34	122.5	359	0.28	8.7
	Wall Panel 26-32	16.1	10	1.6	34	122.5	359	0.28	8.1
Norwegian Geotechnical Institute	Wall Section J	15.7	4	2.2	38	108.8	1044	0.47	0.4
	Wall Section N	15.7	7	2	38	108.8	1044	0.47	1.8
Japan Railway Test Embankment	JR Embankment No. 1	16.4	16	1	35 (a)	93.2	0	0.27	3.5
Highbury Avenue	Highbury Ave. Wall	23.3	9	0.4	35 (a)	125 (a)	0	0.27	8.2
Federal Highway Administration	Wall No. 9	20	8	2.5	39	125.6	728.6	0.23	7.9
Seattle Preload Fill	Southeast Wall	41.3	33	1.25	36	130	2210	0.26	2.6

Legend

n = Number of reinforcement layers

 s_{avg} = Average spacing between reinforcement layers ϕ = Design internal friction angle γ = Design unit weight

q = Surcharge

Ka = Active lateral earth pressure coefficient

CI = Conservatism Index

Note:

a) Estimated value

The CI is an index value to indicate the relative conservativeness of a design. Similar to a factor of safety concept, a CI value close or less than one is considered a less conservative design. A design with a greater CI value is more conservative relative to a design with a smaller CI value. As an example, if project A has a DI value of 3 and project B as a DI value of 5, theoretically, project B should perform better (i.e., smaller displacements and strains) than project A.

The CI for the selected projects ranged from 0.4 to 8.7. The less conservative designs have a CI of 0.4 and include the Interstate Highway 70 through Glenwood Canyon project and wall section 'J' of the Norwegian Geotechnical Institute project. Both these walls were purposely designed using less conservative assumptions, however still performed very well. Since none of the selected projects exhibited large strains, it is difficult to correlate the CI value with an under designed GRS retaining wall to determine the lower bound CI. However, a CI value greater than 0.4 would indicate a more conservative design since the walls with the lower CI values demonstrated good long-term performance.

The Tanque Verde - Wrightstown - Pantano Roads project wall panels, Highbury Avenue and Federal Highway Administration projects have CI values ranging from 7.9 to 8.7. Each of these projects used high tensile strength reinforcement ranging from 2,000 lb/ft to 5,400 lb/ft (short-term strength). For comparison, the Interstate Highway 70 through Glenwood Canyon wall used reinforcement layers with a short-term tensile strength of 220 lb/ft.

3.3.1 Creep-Rate and the Creep Modulus

Creep-rate is the time-rate at which a GSR retaining wall deforms under a sustained load. The change in the creep-rate can be used to

quantify the stabilization of a GRS retaining wall due to creep. A constant creep-rate would indicate that the wall is deforming at a constant rate which would be considered secondary creep. An increasing creep-rate would indicate that the wall is deforming at an increasing rate which would be considered tertiary creep.. In either cases, the wall could conceivably reach a creep failure condition. Conversely, a decreasing creep-rate would indicate that the wall was stabilizing with time reaching an equilibrium condition.

Figure 3.8 illustrates the creep rates computed for the selected projects. As illustrated on Figure 3.8, there is a decreasing trend in the creep-rates indicating the GRS walls were stabilizing over time. This behavior has also been observed in laboratory soil/geosynthetic composite creep tests conducted by Ketchart and Wu (1996). Moreover, the decreasing trends were close to linear when plotted on logarithmic scale. The slope of the linear relation is referred to as the creep modulus (CM). The CM is illustrated in the example below on Figure 3.7.

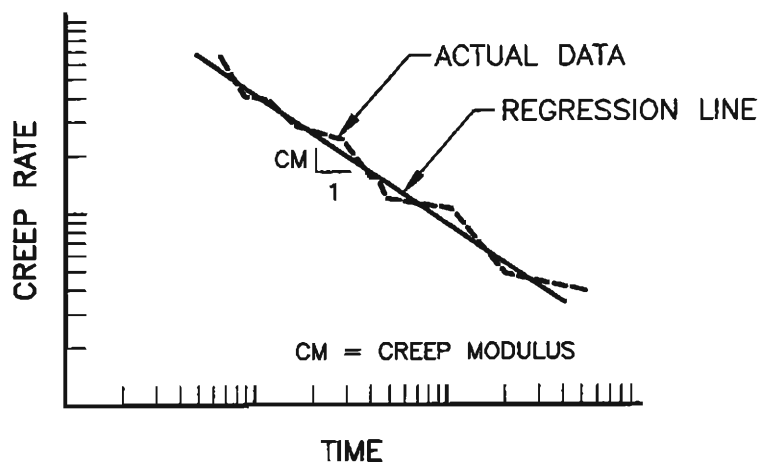

Figure 3.7: Creep-rate-Time Curve Illustrating the Creep Modulus

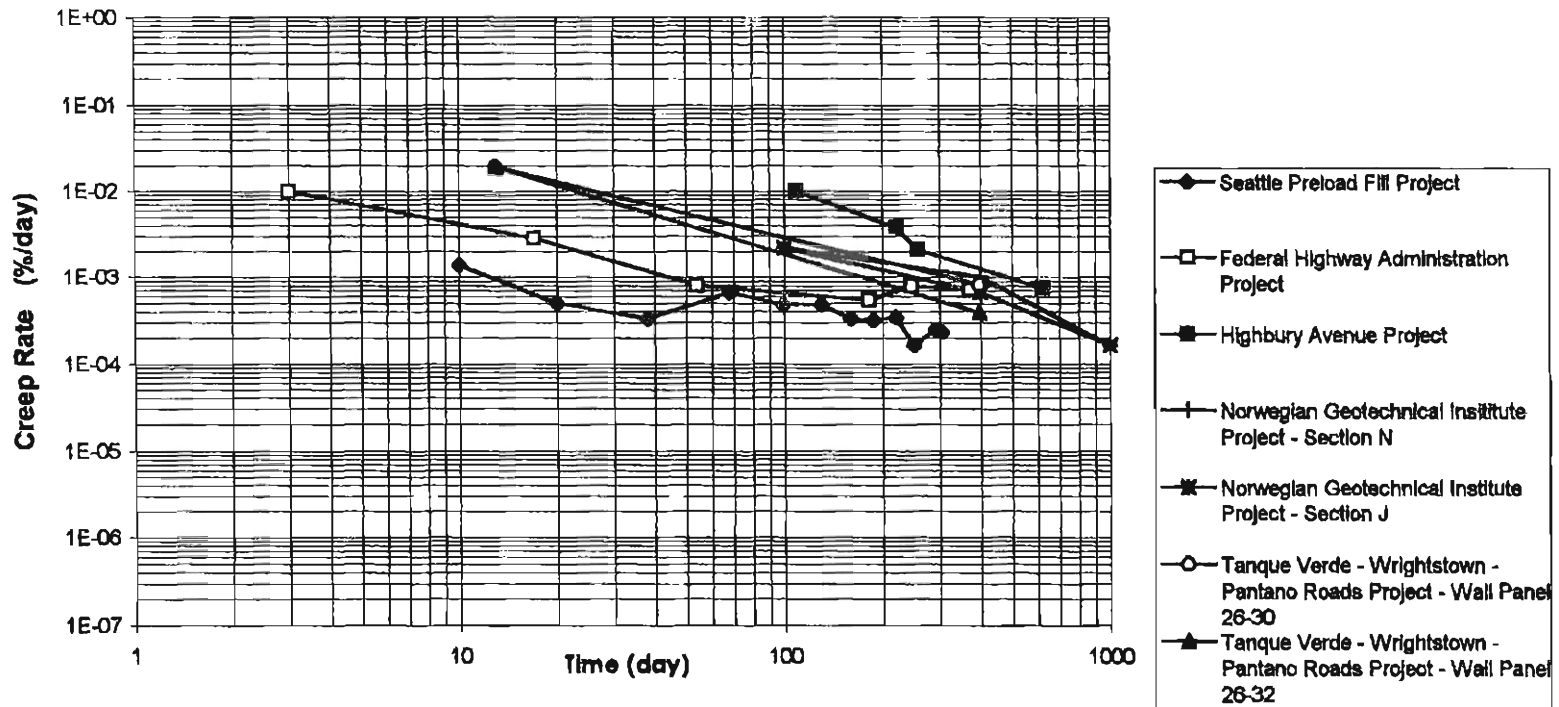

Figure 3.8
Creep-Rate-Time Curve for the Selected Projects

The CM value provides a means to characterize the long-term performance by quantifying the slope of the creep-rate time curve. The CM computed for each project are listed in Table 3.3. The regression lines used to compute the CM are illustrated on the Figures C.1 through C.5 in Appendix C. The CM for the selected projects range from 0.57 to 1.13 %/day². This is a fairly narrow range given the wide variety of retaining wall types in the study. The decreasing slope in the creep-rate and similar slopes were also observed in the laboratory tests performed by Ketchart and Wu (1996). The CM may be a good parameter to characterize the creep behavior of the soil/geosynthetic interaction which will be discussed in Chapter 5.

Based on the CM, the creep-rate for the selected projects are decreasing at a rapid rate indicating that the walls are stabilizing with time. Moreover, it demonstrates the arbitrary nature of reducing the reinforcements short-term strength by up to 80 percent using element creep tests, CRCs and/or partial factors of safety.

Table 3.3
Creep Modulus for the Selected Projects

Project	Wall Name	Height (ft)	t (years)	R ² (%)	CM (%/day ²)
Interstate Highway 70 through Glenwood Canyon	Geotextile Earth Retaining Wall	16	0.8	NA(a)	NA
Tanque Verde-Wrightstown - Pantano Roads	Wall Panel 26-30	15.6	7	1(b)	0.92
	Wall Panel 26-32	16.1	7	1(b)	1.13
Norwegian Geotechnical Institute	Wall Section J	15.7	4	98	1.1
	Wall Section N	15.7	4	89	1.08
Japanese Railway Test Embankment	JR Embankment No. 1	16.4	2	NA	NA
Highbury Avenue	Highbury Ave. Wall	23.3	2	98	1.5
Federal Highway Administration	Wall No. 9	20	1	89	0.57
Seattle Preload Fill	Southeast Wall	41.3	1	68	0.41

Legend

R² = Regression confidence coefficient.

CM = Creep modulus. Positive indicates decreasing slope.

t = Monitoring duration

Notes

a) NA indicates that data was unavailable for computation.

b) R² = 1 since regression line developed from two data points.

4. An Approach to Estimating Creep Using a Laboratory Test

Chapter 3 demonstrated that the current design methods significantly over-estimate the magnitude of strain in the geosynthetic reinforcement and movement of the wall face caused by creep. However, the longest period of performance data for any of GRS retaining wall is less than 10 years. Most applications require that permanent retaining walls be designed for a minimum service life of 75 to 100 years (AASHTO, 1992). Thus, a rational means for estimating creep based on the soil/geosynthetic interaction is needed. This Chapter describes an approach for estimating creep using a simple laboratory test and analytical solution.

4.1 Creep in Laboratory Tests

Development of the method begins with evaluating recent laboratory tests conducted at the University of Colorado at Denver to determine creep behavior of soil/geosynthetic composites. Wu (1994a) and Wu and Helwany (1996) developed a laboratory test procedure to characterize the soil/geosynthetic composite behavior. The apparatus used in for the procedure allows the stresses applied to the soil to be transferred to the geosynthetic reinforcement in a manner similar to typical GSR walls. Using the device, they conducted two long-term performance tests, one using a clay backfill and the other using a sand backfill. A second study was performed in 1995 by Ketchart and Wu (1996). They simplified the testing apparatus device and performed tests on various soils and geosynthetics under different conditions, including accelerated creep tests at elevated temperatures.

In both studies, it was observed that the long-term deformation behavior of the soil/geosynthetic composite was significantly affected by the time-dependent behavior of the soil and the geosynthetic reinforcement. In general, if the confining soil has a tendency to creep faster than the geosynthetic reinforcement, the geosynthetic will impose a restraining effect on the deformation of the soil through friction and/or adhesion between the two materials. Ketchart and Wu (1996) observed that in each case with granular soil, the creep rate decreased over time. This behavior was also observed in the reinforcement strains for the full-scale walls described in Chapter 3. The following subsections describe the laboratory test, the test results and the procedure developed to estimate creep deformation over the design life of a GRS wall.

4.1.1 Laboratory Creep Test Descriptions

The test apparatus developed by Wu and Helwany (1996) consists of a Plexiglas box with thin sheet-metal sides approximately 1.5 feet by 3 feet in size. A layer of reinforcement is sandwiched between two soil blocks placed inside the box using techniques similar to field construction procedure. Then the composite is loaded with a sustained surcharge load. The side-wall adhesion between the Plexiglas and the soil was minimized by creating a lubrication layer at the interface of the two materials to create plain strain conditions. The test apparatus is illustrated on Figure 4.1

One of Wu and Helwany's tests consisted of placing an Ottawa sand into the testing apparatus using an air-pulviation method. Once half the sand was placed, a layer of geotextile was placed and securely attached to the two sheet metal plates, followed by the remaining sand. Another layer of geotextile was then placed at the top of the sand. The soil/geosynthetic

composite was loaded with a sustained vertical load of approximately 16 lb/in² for 30 days. The stress-strain behavior of the geotextile was determined by performing a series of element geotextile creep tests to compare its behavior with the behavior of the soil/geosynthetic composite. Lateral and vertical deformation and reinforcement strain were measured over the testing period. The test results indicate that the element creep test over-estimated the strain in the reinforcement by a factor of four consistent with the performance of the full-scale retaining walls described in Chapter 3.

Ketchart and Wu modified the apparatus developed by Wu and Helewany so that the lateral supports could be released to model “worst” case conditions. This would be similar to removing the modular blocks or other type of facing from the front of a GRS retaining wall, exposing the soil and the reinforcement. Similar to previous test procedures, soil was placed in the test apparatus and compacted to mid-height. A layer of geotextile reinforcement was then placed (without attaching to the side walls) followed by compacted soil to the top of the apparatus. The sample was then subjected to a sustained surcharge for a period of 30 days. In some cases, the apparatus was placed in a room with elevated temperatures to accelerate creep of the geosynthetic. The test apparatus is illustrated on Figure 4.2.

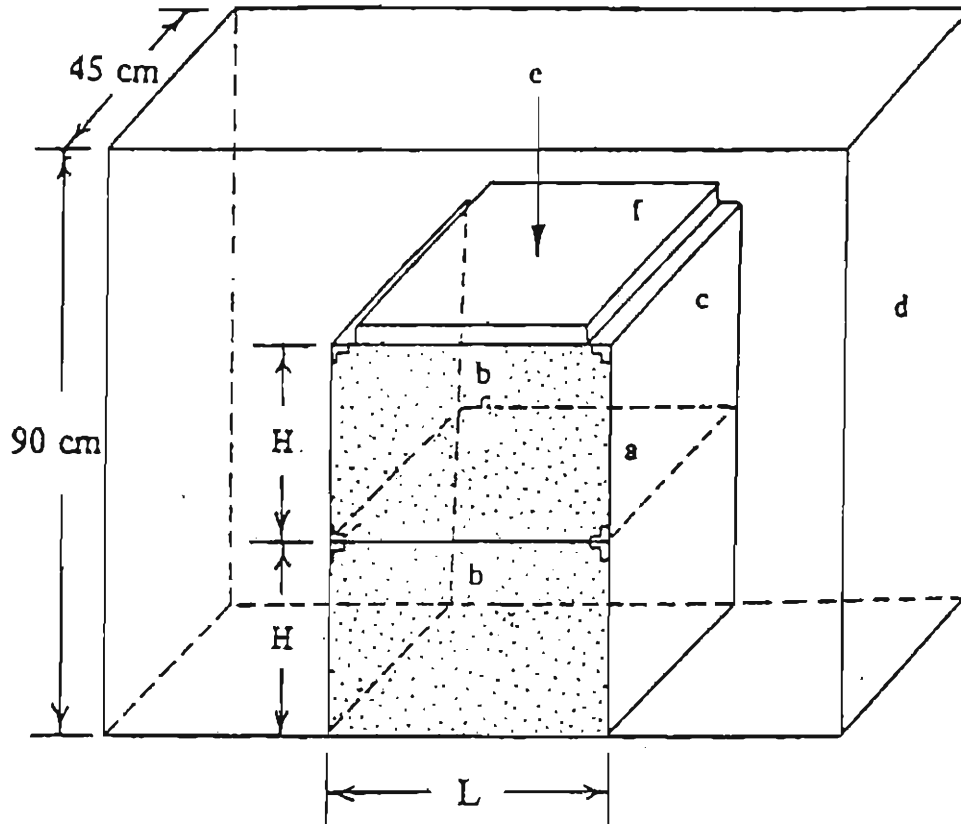

Dimensions:

Sand-Backfill Test:

L = 81.3 cm

H = 30.5 cm

Clay-Backfill Test:

L = 45.7 cm

H = 25.4 cm

Legends:

a Geosynthetic Reinforcement

b Soil

c Steel Plate

d Rigid Container with
Lubricated Side Walls

e Sustained Load

f Rigid Plate

Figure 4.1
Schematic of the Long-Term Soil/Geosynthetic Performance
Test Device (Helwany and Wu, 1996)

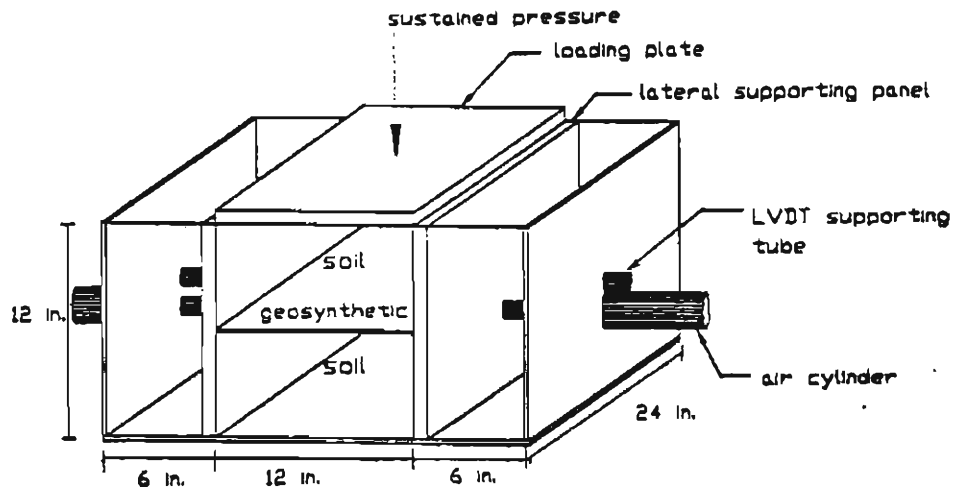

(a) Before Releasing Lateral Supporting Panels

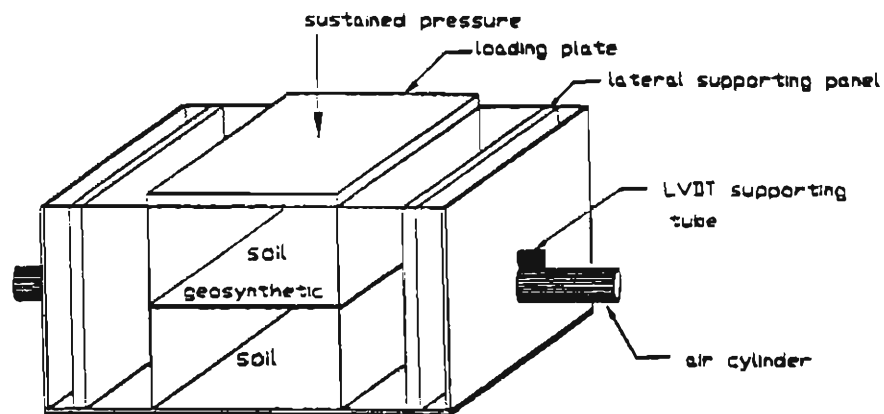

Figure 4.2
Schematic of the Modified Long-Term Soil/Geosynthetic Performance
Test Device (Wu and Ketchart, 1996)

The types of tests performed during Ketchart and Wu's study are described below.

A total of 11 tests were performed during the study. From the testing program, six of the tests conducted using a granular backfill is of interest for this report. These include the tests described below (Ketchart and Wu, 1996).

- Test D-1: Test D-1 was performed using a heat-bonded nonwoven polypropylene low-strength geotextile having a short-term tensile strength of 420 lb/ft. and an average vertical pressure of 15 lb/in² at a temperature of 70° F. The test was performed to determine the creep behavior of the soil/geosynthetic composite using a low-strength reinforcement. Reinforcement strain was measured in addition to lateral and vertical displacement.
- Test H-1: Test H-1 was performed using a woven geotextile having a short-term tensile strength of 4800 lb/ft and an average pressure of 30 lb/in² at a temperature of 125°F. The test was performed to determine the creep behavior of the soil/geosynthetic composite using a large load at an elevated temperature.
- Test R-1: Test R-1 was performed using a woven geotextile having a short-term strength of 4800 lb/ft and an average vertical pressure of 15 lb/in² at a temperature of 70 °F. The test was performed to determine temperature effects on the creep behavior of the soil/geosynthetic composite by comparing the results with test R-2.
- Test R-2: Test R-2 was performed using the same material and loading as R-1 except at an elevated temperature of 125°F. The test was performed to determine temperature effects on creep behavior of the soil/geosynthetic composite by comparing the results with test R-1.
- Test R-3: Test R-3 is a duplicate test of R-2 to determine the repeatability of the test method.
- Test W-1: Test W-1 was performed using a woven geotextile having a short-term tensile strength of 1440 lb/ft and an average pressure of 15 lb/ in² at an elevated temperature of 125 °F. The test was performed to determine the temperature impacts to the creep

behavior of the soil/geosynthetic composite using a low strength reinforcement.

The granular backfill consisted of a road base comprising of a silty sandy gravel. The soil was prepared 2 percent wet of optimum moisture content and compacted to 95 percent of the relative density or approximately 126 lb/ft³ having an internal friction angle of 34°.

4.1.2 Laboratory Test Creep Rate

Ketchart and Wu measured lateral and vertical displacements and in one test, strain in the reinforcement due to creep. Lateral displacements were measured using linear voltage deformation transducers installed at the mid-height of the testing apparatus where the reinforcement was located. Strain was measured in the reinforcement for test D-1 only. The lateral displacement over the time period for each of the above tests are plotted on Figure 4.3. From the lateral displacement data, the lateral creep rate was computed and plotted on Figure 4.4. The creep rate based on the measured maximum strain in the reinforcement for test D-1 is also shown.

As illustrated on the Figure 4.3, the effects of geosynthetic strength, temperature, and loading all impact the time-dependent behavior of the soil/geosynthetic composite as to be expected. However, there is a linear decreasing trend in the creep rates of all the tests when plotted on a logarithmic scale as illustrated on Figure 4.4. After performing a linear regression on each of the data sets, the confidence (R-squared) coefficient is on the order of 94 percent demonstrating a good linear fit. Moreover, the slopes of the linear relation or CM are approximately the same for all the tests.

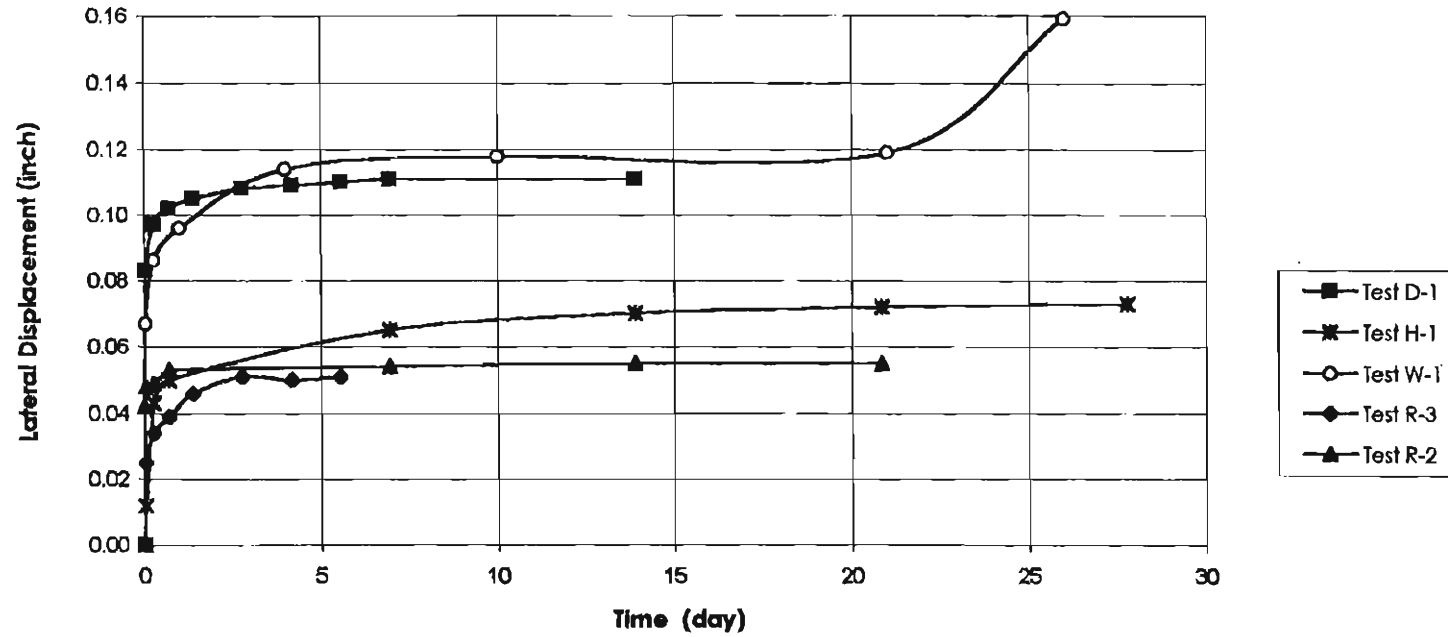

Figure 4.3
Lateral Displacement-Time Curves for Soil/Geosynthetic Laboratory Test

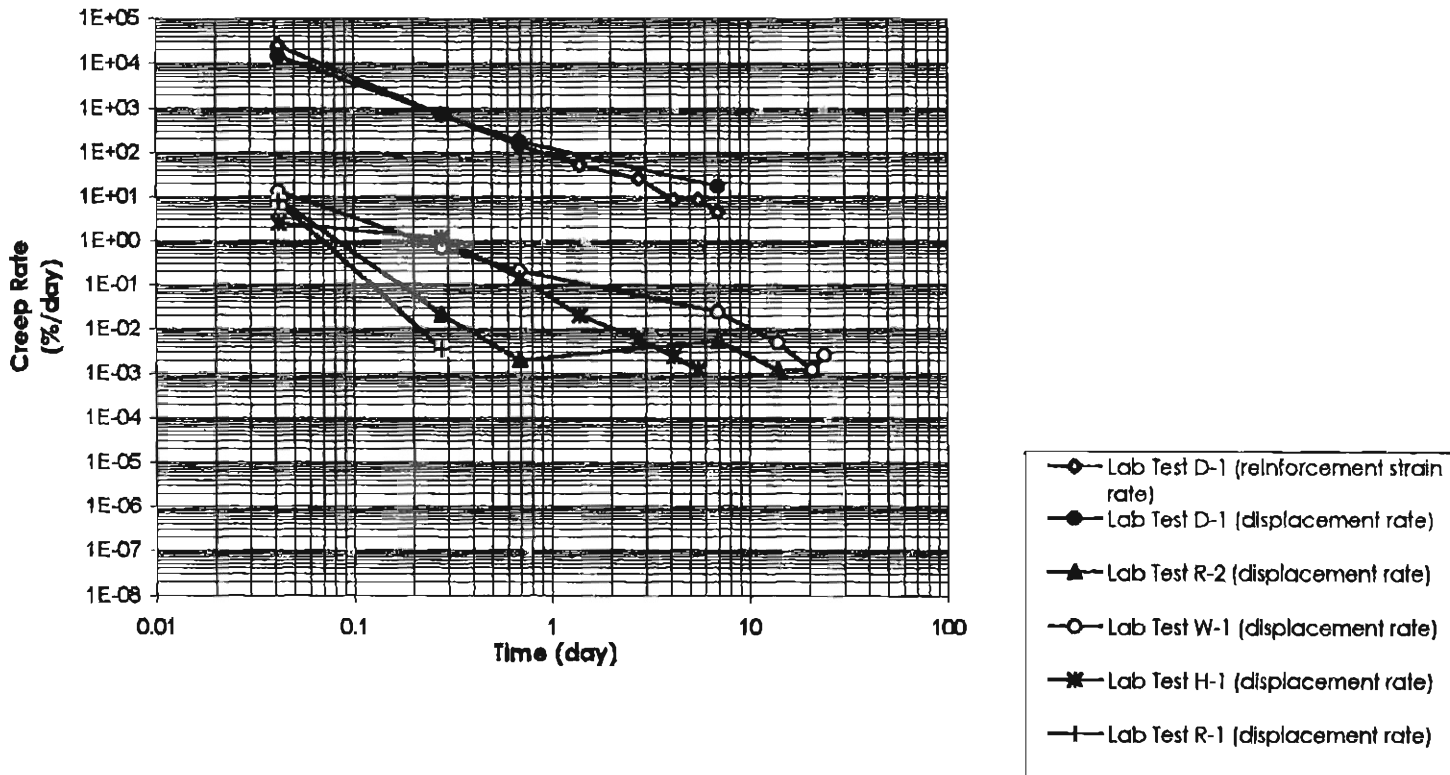

Figure 4.4
Creep-Rate-Time Curves from Soil/Geosynthetic Laboratory Test

4.2 Laboratory and Full-Scale Creep Rate Comparison

Figure 4.5 illustrates the creep rates computed for the selected full-scale projects and the creep rates computed from the lateral displacement of the laboratory tests. It is observed that the full-scale data fits well with the laboratory data and shows a continuing decreasing trend in the creep rate. Moreover the CM for the selected projects and the laboratory tests are nearly the same. The CM values are listed in Table 4.1. The plots used to compute the CM values are provided in Appendix C.

The full-scale creep performance also demonstrates the validity of the testing procedure developed by Ketchart and Wu by accurately modeling the soil/geosynthetic integration of a full scale GRS retaining wall with granular soil. The full-scale creep performance also demonstrates that the laboratory procedure can determine the creep behavior of a soil/geosynthetic composite material consisting of granular soil in a relatively short amount of time unlike the 10,000 hour element creep tests currently required.

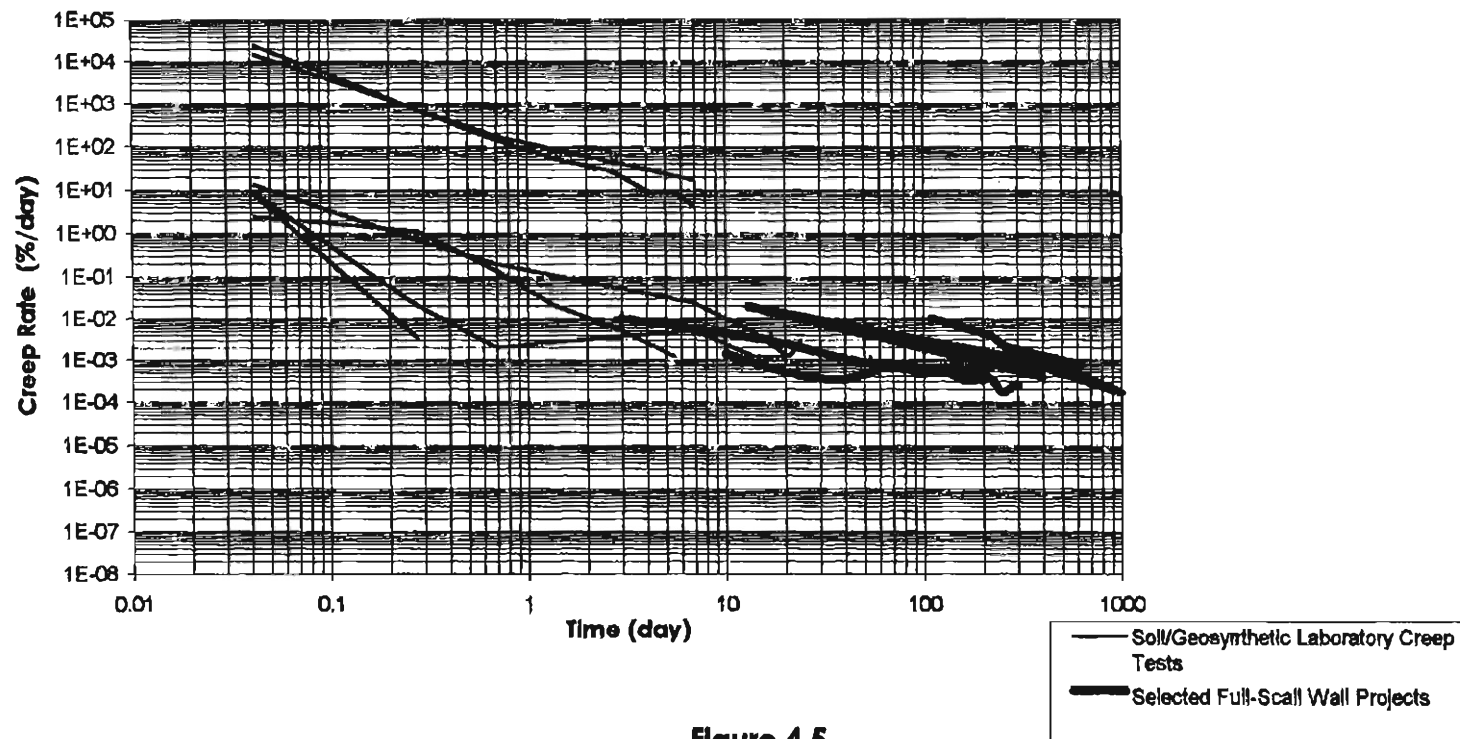

Figure 4.5
Combined Creep-Rate-Time Curves from Selected Projects and Laboratory Tests

**Table 4.1
Creep Modulus for the Full-Scale Walls and Laboratory Tests**

Project	Wall Name	Height (ft)	t (years)	R ² (%)	CM (%/day)
Interstate Highway 70 through Glenwood Canyon	Geotextile Earth Retaining Wall	16	0.8	NA(a)	NA
Tanque Verde-Wrightstown - Pantano Roads	Wall Panel 26-30	15.6	7	1(b)	0.92
	Wall Panel 26-32	16.1	7	1(b)	1.13
Norwegian Geotechnical Institute	Wall Section J	15.7	4	98	1.1
	Wall Section N	15.7	4	89	1.08
Japanese Railway Test Embankment	JR Embankment No. 1	16.4	2	NA	NA
Highbury Avenue	Highbury Ave. Wall	23.3	2	96	1.5
Federal Highway Administration	Wall No. 9	20	1	89	0.57
Seattle Preload Fill	Southeast Wall	41.3	1	66	0.41
Laboratory Test	D-1	1	0.08	99	1.41
Laboratory Test	H-1	1	0.08	96	1.17
Laboratory Test	R-1	1	0.08	1(b)	4.06
Laboratory Test	R-2	1	0.08	94	1.36
Laboratory Test	W-1	1	0.08	98	1.35

Legend

R² = Regression confidence coefficient.

CM = Creep modulus. Positive Indicates decreasing slope.

t = Monitoring period

Notes

a) NA indicates that data was unavailable for computation.

b) R² = 1 since regression line developed from two data points.

4.3 An Analytical Solution for Estimating Creep Strain

The previous sections demonstrated that the creep-rate for the laboratory soil/geosynthetic composite tests and full-scale walls could be represented as a straight line when plotted on a logarithmic scale. To determine the creep strain at any given time, the strain-rate can be plotted with time as illustrated in Figure 4.3.

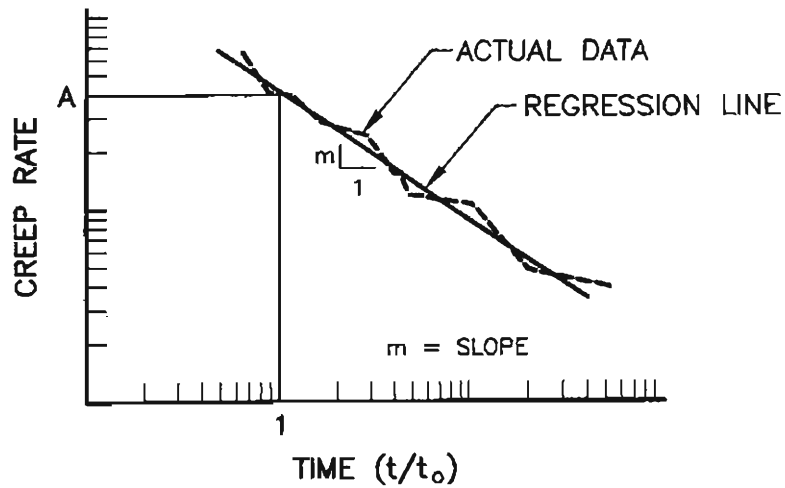

Figure 4.3: Creep-Rate-Time Ratio Plot

Using the plot illustrated on Figure 4.3, the linear relationship can be represented by the following equations:

$$\log\left(\frac{d\varepsilon_c}{dt}\right) := -m \cdot \log\left(\frac{t}{t_o}\right) + \log(A) \quad \text{Equation 4.1}$$

or,

$$\frac{d\varepsilon_c}{dt} := A \cdot \left(\frac{t}{t_o}\right)^{-m} \quad \text{Equation 4.2}$$

Where: $\frac{d\varepsilon_c}{dt}$ = Creep-rate (%/day)
 m = Slope of the $\log(t/t_o)$ vs. $\log(d\varepsilon_c/dt)$ curve
 A = Creep-rate coefficient (%/day)
 t = Time (day)
 t_o = Reference time (day)

The creep-rate coefficient (A) is the creep-rate corresponding to a t/t_o value of one. The reference time (t_o) is the time at which the creep-strain begins. Typically this would be at the end of construction of a wall. For example, if it took 30 days to complete the construction of the wall, t_o would be 30 days.

Integrating Equation 4.2 gives the creep-strain expressed in Equation 4.3:

$$\varepsilon_c := \frac{A \cdot t_o}{1 - m} \cdot \left(\frac{t}{t_o}\right)^{1 - m} + C \quad \text{Equation 4.3}$$

Where: C = Integration constant

Equation 4.3 can be solved by two unique solutions. Knowing that the creep strain (ϵ_c) is zero at $t = t_0$, C will be equal to $\frac{-A \cdot t_0}{1 - m}$ when the slope (m) is not equal to 1. When the slope (m) is equal to 1, C equals zero. Thus, the analytical solution for determining creep strain at a given time can be expressed by Equations 4.4 and 4.5:

$$\epsilon_c := \frac{A \cdot t_0}{1 - m} \cdot \left(\frac{t}{t_0} \right)^{1 - m} - \frac{A \cdot t_0}{1 - m} \quad \text{When: } m \neq 1 \quad \text{Equation 4.4}$$

$$\epsilon_c := A \cdot t_0 \cdot \ln \left(\frac{t}{t_0} \right) \quad \text{When: } m = 1 \quad \text{Equation 4.5}$$

Note that Equations 4.4 and 4.5 are only valid for a soil/geosynthetic composite that exhibits a constant value of m. The smaller the m value, the larger the creep-strain.

5. Summary and Conclusions

5.1 Summary

The three main research objectives of this study included:

1. Compile long-term performance data from field projects involving well-instrumented GRS retaining walls;
2. Develop a means to quantify the conservativeness of the designs; and
3. Develop a rational method to estimate creep based on laboratory creep test of the soil/geosynthetic composite deformation.

The first objective was accomplished by surveying experts in GRS technology and performing an extensive literature search. From the survey and literature search, seven well-documented GRS retaining wall projects around the world were described and analyzed.

The second objective was achieved by showing that walls designed using a CRC that was greater than the CRCs recommended by AASHTO (i.e., less conservative) performed exceptionally well under a variety of conditions. The CI was developed to provide a measure of conservativeness in the designs. Even with a low CI for some of the projects, the walls performed exceptionally well.

The third objective was achieved by developing a simple procedure for estimating creep based on the observed decreasing creep-rate of the soil/geosynthetic composite. By using the simple testing procedure developed by Ketchart and Wu and the analytical solution, the creep can be predicted for any given time after construction for project specific soil and reinforcement types.

5.2 Conclusions

From the study, the following conclusions can be made:

1. *GRS retaining walls with granular backfill deform very little due to creep:*
The GRS retaining walls selected for the study represent a variety of wall types using granular backfill and field conditions. The maximum creep-strain in the reinforcement were less than 1.5 percent.

2. *The actual reinforcement load is over-estimated:*

In some of the selected walls, the tensile load in the reinforcement could be estimated. In all those cases the tensile load was less than 10 percent of the reinforcements short-term strength. This suggests that the design strength required for the reinforcement is too large (overconservative). The design strength is the result of overconservative creep reduction coefficients (CRCs) and partial factors of safety required by the AASHTO design method. This results in limiting the type of reinforcement in GRS walls to only higher-cost, high-strength geosynthetics.

3. *The GRS retaining walls were stabilizing with time:*

In all of the selected walls and laboratory tests, the creep-rate was decreasing with time indicating that the walls were stabilizing with time. The tensile forces in the reinforcement are likely to decrease with time as the creep strain-rate becomes very small (known as "stress relaxation").

4. *A simple laboratory test and analytical equation can be used to predict creep:*

It was observed that the logarithmic creep-rate for the full-scale walls and laboratory soil/geosynthetic composite tests decrease in a linear relationship with logarithmic time. From this observation, an analytical equation can be used to predict creep during the design-life of a GSR wall. In full-scale applications, the simple test developed by Ketchart and Wu may be performed to determine the creep modulus of a project specific geosynthetic/soil composite. Long-term creep deformation of the wall can then be determined in a rational manner by the analytical solution.

5.3 Recommendations for Future Study

A wide variety of GRS retaining walls are being studied based on the literature search and survey. However, the focus of the research seems to be in several directions. The overall direction of the projects selected for this

study was mainly to demonstrate the functionality of geosynthetic soil reinforcement and that it basically "works". The projects selected can be considered the first full-scale GRS retaining walls in field conditions that have been monitored for extended period of times. Future research in monitoring the performance of full-scale walls should be focused in the areas of lateral earth pressure distribution, location of the failure surface and creep so that specific data is collected to better understand the complex behavior of the soil/geosynthetic composite.

Future research is required to determine the impact of material types and the environment on the creep-rate relationship used to predict creep-strain. Eventually, a database of creep-rate-time curves for specific soil/geosynthetic composites could be established so that the magnitude of creep can be estimated using analytical solutions.

Appendix A
Project Description Sheets

Interstate Highway 70 through Glenwood Canyon Project

Geotextile Earth Retaining Wall Glenwood Springs, Colorado, USA

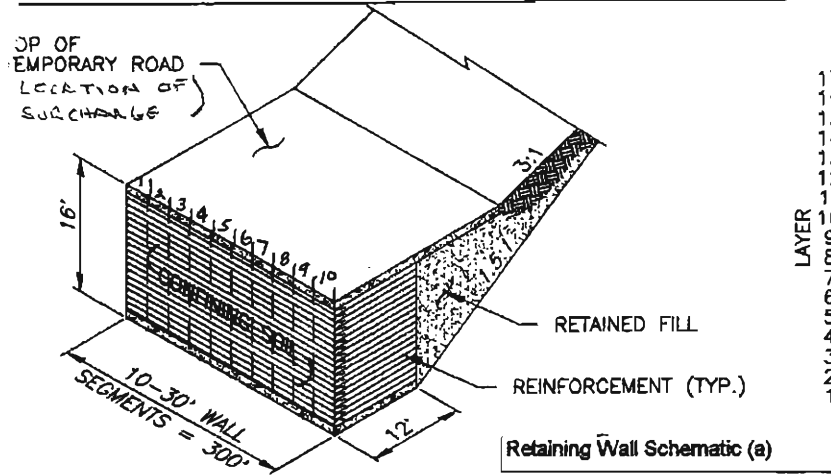

		GEOTEXTILE TYPE									
17	8	8	4	2	7	5	3	1	8	6	
16	8	8	4	2	7	5	3	1	8	6	
15	8	8	4	2	7	5	3	1	8	6	
14	8	8	4	2	7	5	3	1	8	6	
13	8	8	4	2	7	5	3	1	8	6	
12	8	8	4	2	7	5	3	1	8	6	
11	8	8	4	2	7	5	3	1	8	6	
10	8	8	4	2	7	5	3	1	8	6	
9	8	8	4	2	8	5	3	1	8	6	
8	8	8	4	2	8	6	3	2	8	6	
7	8	8	4	2	8	6	3	2	8	6	
6	8	8	4	2	8	6	3	2	8	6	
5	8	8	4	2	8	6	3	2	8	6	
4	8	8	4	2	8	6	3	2	8	6	
3	5	5	5	5	5	5	5	5	5	5	
2	5	5	5	5	5	5	5	5	5	5	
1	5	5	5	5	5	5	5	5	5	5	
	1	2	3	4	5	6	7	8	9	10	

Retaining Wall Schematic (a)

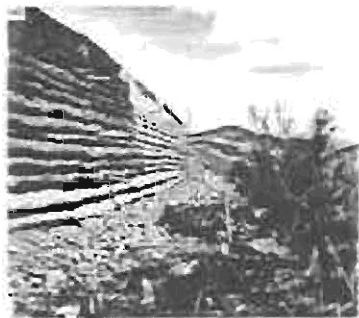

Wall Construction (b)

Project Information

Wall Components (c)

Confining Soil: Well graded clean sandy gravel
 Foundation Soil: Compressible silts and clays
 Reinforcement: Geotextile (nonwoven polypropylene and polyester)
 Facing: Wrapped face with shotcrete

Reinforcement Strength

	Short Term Strength (e)	Creep Limited Strength (f)	Creep Reduction Coefficient (g)
1 - PP	400 lb/ft @ 140% strain	220 lb/ft	55%
2 - PP	680 lb/ft @ 145% strain	375 lb/ft	55%
3 - PP	860 lb/ft @ 65% strain	345 lb/ft	40%
4 - PP	1665 lb/ft @ 60% strain	670 lb/ft	40%
5 - PE	455 lb/ft @ 80% strain	295 lb/ft	65%
6 - PE	1155 lb/ft @ 75% strain	750 lb/ft	65%
7 - PP	525 lb/ft @ 60% strain	210 lb/ft	40%
8 - PP	850 lb/ft @ 55% strain	340 lb/ft	40%

Confining Soil Properties (c)

Unit Weight: 130 lb/ft³
 Friction Angle: 35°

Surcharge (c)

Permanent Fill - 15 ft high

Schedule (c)

Activity	Apr-82	Oct-82	June-83	84	93
Construction					
Monitoring					
Surcharge					
Exhumation (h)					

Notes

- a) Monitoring instruments are not shown for clarity.
- b) Excerpted from "Geotextile Earth-Reinforced Retaining Wall Tests: Glenwood Canyon, Colorado" (Bell, 1983).
- c) Information excerpted from the Federal Highway Administration's report entitled "Evaluation of Fabric Reinforced Earth Wall". (Derakhshandeh and Barrett, 1986).
- d) PP = polypropylene type polymer. PE = polyester type polymer (Derakhshandeh and Barrett, 1986).
- e) The short term strength was determined by the wide width tensile test at a constant strain rate of 10%. The specimens were soaked in water prior to the test (Derakhshandeh and Barrett, 1986).
- f) The creep limited strength was determined by multiplying the short term strength by the creep reduction coefficient.
- g) The creep reduction coefficients were determined by reinforcement element tests performed by Dr. Richard Bell at Oregon State University (Derakhshandeh and Barrett, 1986).
- h) Reinforcement samples were exhumed in 1984 to investigate survivability (Bell and Barrett, 1994).

Tanque Verde-Wrightstown-Pantano Roads Project

Wall Panels 26-30 and 26-32

Tucson, Arizona, USA



Wall During Construction (a)

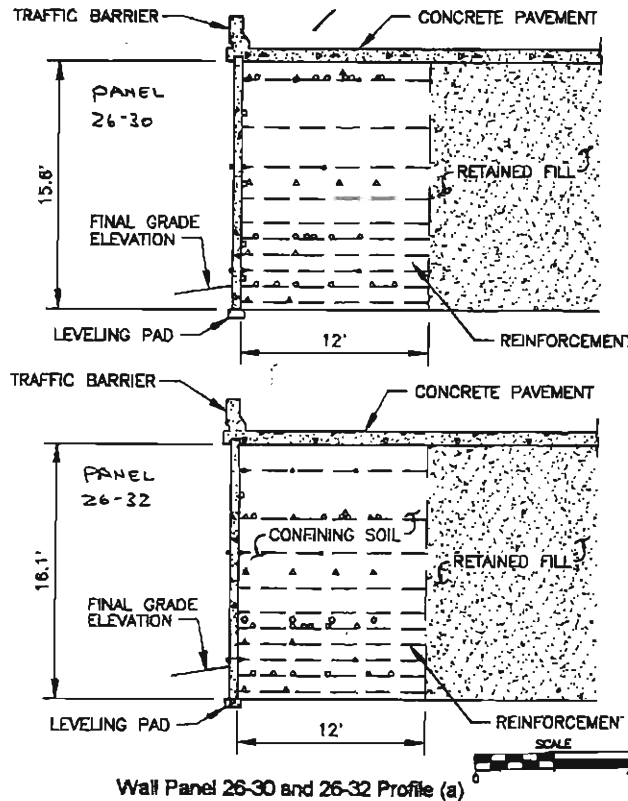

Wall Panel 26-30 and 26-32 Profile (a)

Project Information	
Wall Components	
Confining Soil:	Well-graded gravelly sand
Foundation:	Well-graded gravelly sand
Reinforcement:	Geogrid
Facing:	Concrete Panels
Reinforcement Strength	
Short term strength:	5400 lb/ft (b)
Creep limited strength:	1933 lb/ft (c)
Performance limit strain:	10% (c)
Factor of safety:	1.5 (d)
Design strength:	1327 lb/ft
Creep Reduction Coef.:	37%
Confining Soil Properties	
Unit Weight:	122.5 lb/ft ³ (a)
Friction Angle:	34° (a)
Surcharge	
Design surcharge = 359 lb/ft ²	

LEGEND

- RESISTANCE THERMOMETER
- ◻ RESISTANCE STRAIN GAUGE
- ▲ INDUCTANCE COIL
- ◻ HORIZONTAL LOAD CELL

Schedule

Activity	Sep-85	Oct-85	86	87	88	89	90	91	Sep-92	Aug-93
Construction										
Monitoring										
Exumation (e)										

Notes

- a) Excerpted from the Federal Highway Administration Report No. FHWA-EP-90-001-005.
- b) Short term strength determined from unconfined tensile test using a 4 inch wide sample tested for all layers at a constant 2% strain rate at standard test conditions of 20° C and 65% relative humidity by McGown, et. al. (1985).
- c) Extrapolated from isochronous stiffness curves developed by McGown, et. al. (1985).
- d) Accounts for uncertainties in design (FHWA, 1989).
- e) A geogrid sample was exhumed from a separate section of the wall for durability analysis (Bright et. al., 1994).

Norwegian Geotechnical Institute Project Wall Sections 'J' and 'N' Skedsmo, Norway

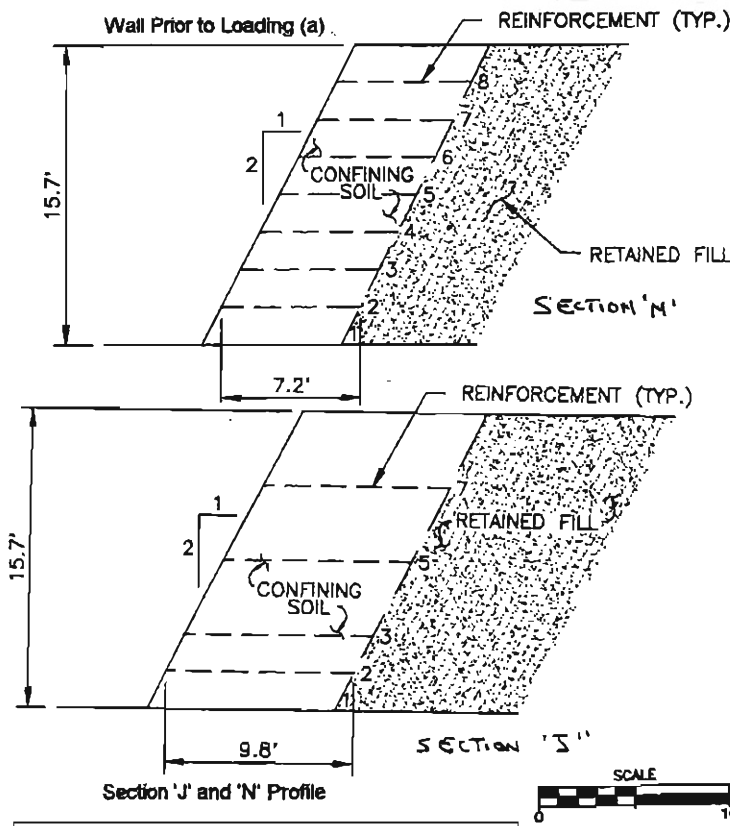

Project Information	
Wall Components(b)	
Confining Soil:	Well-graded medium to fine sand
Foundation Soil:	Gravelly sand
Reinforcement:	Geogrid (polypropylene)
Facing:	Exposed
Reinforcement Strength (c)	
Primary Reinforcement	
Short term strength:	3600 lb/ft @ 13% strain
Intermediate Reinforcement	
Short term strength:	833 lb/ft @ 14% strain (Longitudinal)
Confining Soil Properties	
Unit Weight:	108.8 lb/ft ³ (b)
Friction Angle:	38° (b)
Surcharge (b)	
6057 lb/ft ² cyclic load	
1044 lb/ft ² uniform surcharge from fill 9.8 ft high	

Notes

a) Excerpted from the paper entitled "Performance data for a sloped reinforced soil wall" (Fannin, 1990).

b) Excerpted from the paper entitled "Geosynthetic Strength - Ultimate and Serviceability Limit State Design" (Fannin, 1992)

c) Personal correspondence (Fannin, 1995). Long term strength values used in the design were not provided.

d) Non-uniform spacing of primary reinforcement (Fannin, 1992).

e) Uniform spacing of primary reinforcement. Intermediate reinforcement was used when spacing of the primary layers exceeded 3 feet (Fannin, 1992).

Activity	Jul-87	Aug-87	Oct-87	88	89	90	Jun-91
Construction							
Self-weight loading							
Cyclic loading							
Permanent surcharge							
Monitoring							

Japanese Railway Test Embankment Project JR Embankment No. 1 Experiment Station of Japan Railway Technical Research Institute



JR Embankment No. 1 at Completion (Background)

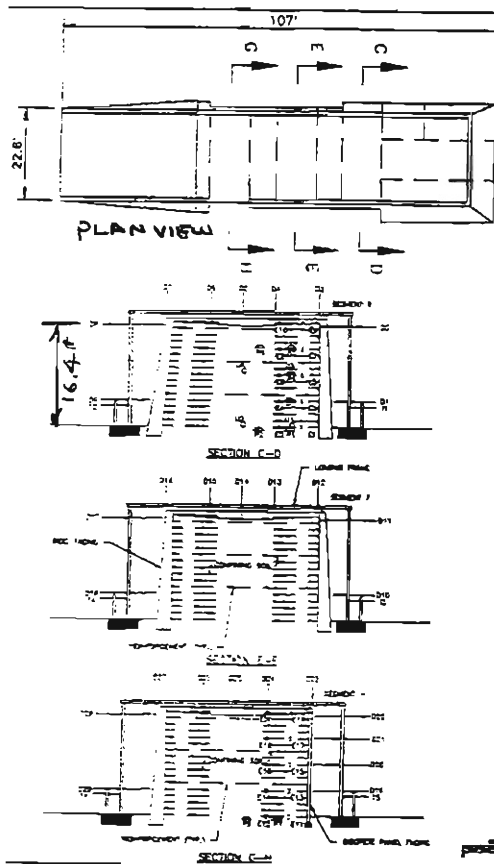

Plan and Cross Sections (b)

Project Information	
Wall Components (a)	
Confining Soil:	Sand with 16% fines
Reinforcement:	Geogrid (Polyester)
Facing:	Cast-in-place unreinforced concrete and discrete panels(b)
Reinforcement Strength	
Short Term Strength:	1880 lb/ft (a)
Confining Soil Properties	
Unit Weight:	93.2 lb/ft ³ (a)

Schedule (a)					
Activity	Dec-87	Jan-88	Feb-88	Dec-89	Jan-90
Construction					
Monitored					
Load test					

Notes

- a) Excerpted from the paper entitled "Permanent geosynthetic-reinforced soil retaining walls used for railway embankments in Japan" (Tatsuoka, 1992).
- b) 5 sections of the test wall had continuous rigid facing of delayed cast-in-place unreinforced concrete with lightly reinforced construction joints. Facing for the middle section consisted of discrete panel sections (Tatsuoka, 1992).

Highbury Avenue Project London, Ontario, Canada

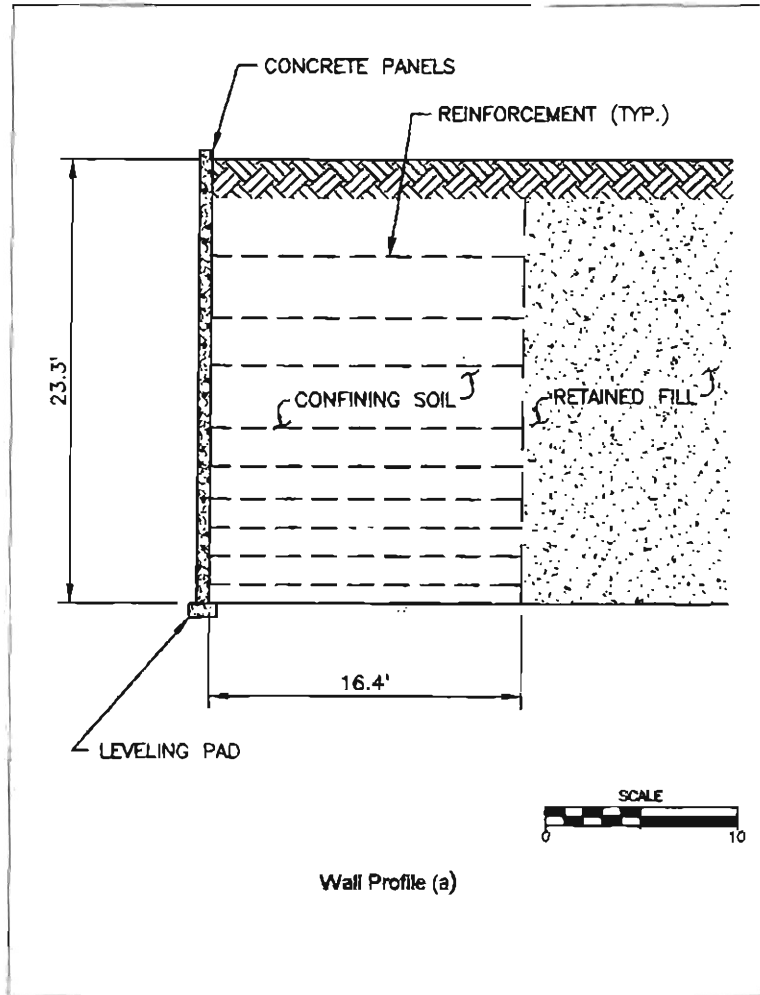

Wall Under Construction (a)

Project Information	
<u>Wall</u>	
Components (b)	
Confining Soil:	Coarse sand
Foundation Soil:	Dense sandy till
Reinforcement:	Geogrid (Polypropylene)
Facing:	Concrete Panels
<u>Reinforcement Strength</u>	
Not Available (c)	
<u>Confining Soil Properties (b)</u>	
Friction Angle: 30° - 40°	
<u>Surcharge</u>	
Traffic Loading	

Schedule (b)			
Activity	Dec-89	90	Aug-91
Construction			
Monitored			

Notes

- a) Excerpted from the paper entitled "Review of Three Instrumented Geogrid Reinforced Soil Retaining Walls" (Bathurst, 1991).
- b) Excerpted from the paper entitled "Case study of a monitored propped panel wall", (Bathurst, 1992).
- c) Specific reinforcement strength data used in the design was not available. However, the reinforcement used was a Tensar UX1600 (Bathurst, 1992). Creep limited strength for UX1600 ranges from 2,000 to 3,450 lb/ft according to manufactures literature (Tensar, 1995).

Federal Highway Administration Research Project

Wall Number 9

Algonquin, Illinois, USA

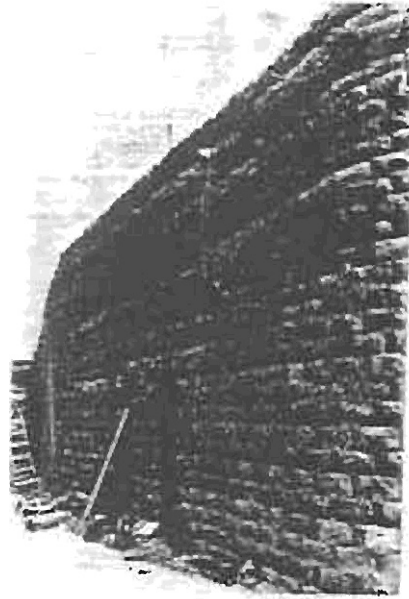

Wall Completion (a)

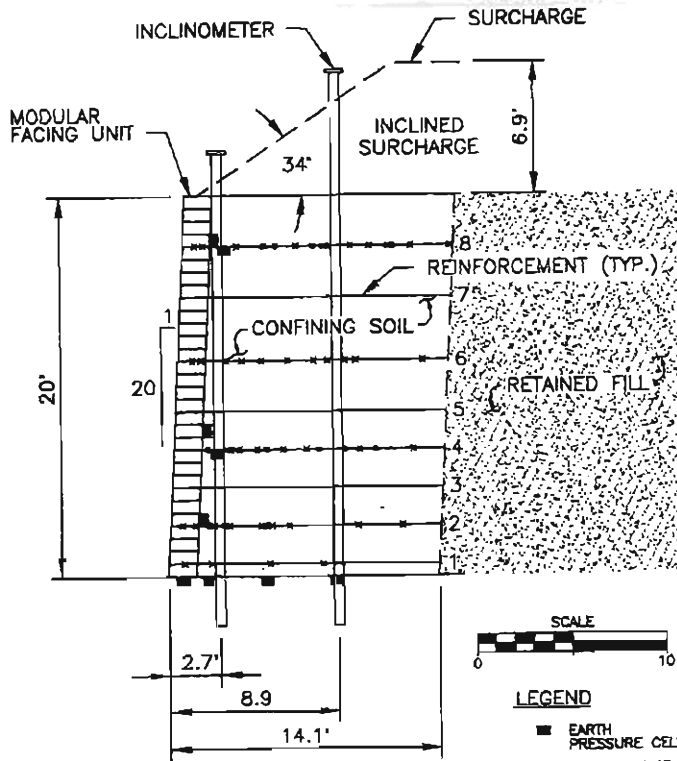

Wall Number 9 Profile

Project Information	
Wall Components (a)	
Confining Soil:	Well graded sand and gravel
Foundation Soil:	Medium dense gravely sand
Reinforcement:	Geogrid (Polyester)
Facing:	Modular Blocks
Reinforcement Strength	
Machine Direction	
Short Term Strength:	2804 lb/ft @ 15% strain (b)
Creep Limited Strength:	1560 lb/ft (c)
Design Strength:	1032 lb/ft (d)
Cross Machine Direction	
Short Term Strength:	1572 lb/ft @ 19% strain
Creep Limited Strength:	924 lb/ft
Design Strength:	636 lb/ft
Performance Limit Strain:	10% (a)
Factor of Safety:	1.5 (e)
Creep Reduction Coef.:	60% (a)
Confining Soil Properties (f)	
Unit Weight:	125.6 lb/ft ³
Friction Angle:	39°
Surcharge(a)	
Uncompacted fill 6.9 feet ft above the top of the wall	
Unit Weight:	105.6 lb/ft ³

Schedule (a)					
Activity	Jun-89	Jul-89	Nov-89	90	Nov-90
Construction					
Surcharged					
Monitored					

Notes

- Excerpted from the paper entitled "Instrumented field performance of a 6 m geogrid soil wall", (Simac, 1990).
- The short term strength is excerpted from Simac (1990). Assumed to be determined based on the wide width tensile strength test (ASTM D-4596).
- The long term strength is excerpted from Simac (1990). Assumed to be Determined using 10,000 hour creep tests described in the Federal Highway Administration's task force 27 report (FHWA, 1989).
- The design strength is determined by dividing the long term strength by the factor of safety.
- The factor of safety accounts for long term durability and construction site damage described in the Federal Highway Administration's task force 27 report (FHWA, 1989).

Seattle Preload Fill Project Southeast Wall Seattle, Washington, USA

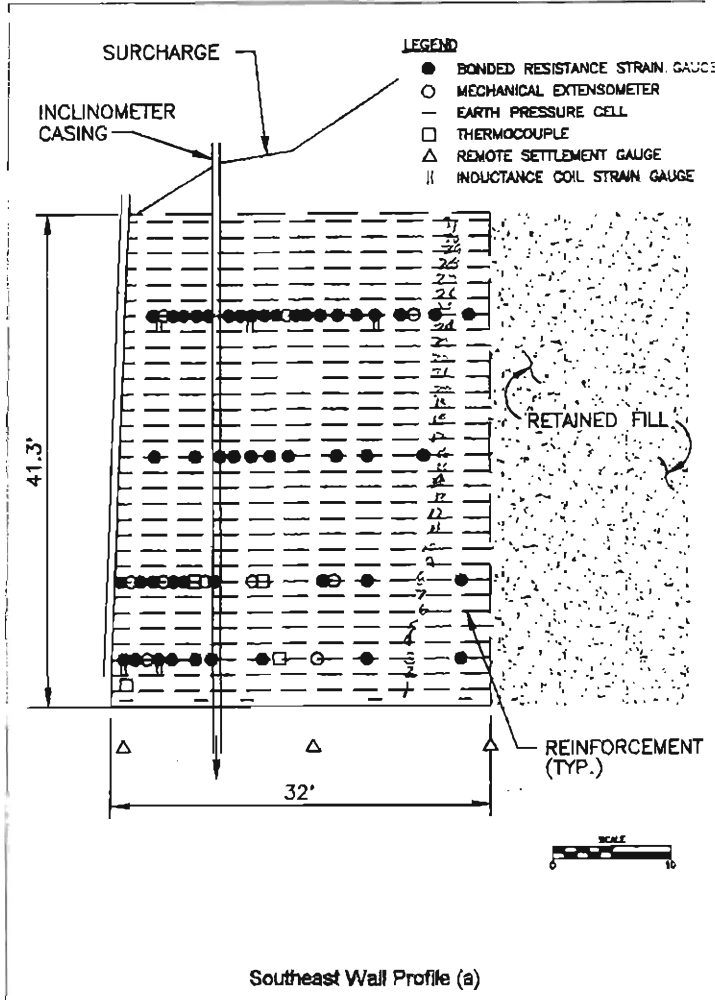

Wall after Construction (a)

Project Information

Wall Components (a)

Confining Soil: Gravely sand
 Foundation: Granular soil overlying compressible soft clay
 Reinforcement: Geotextile
 Facing: Wrapped face

Reinforcement Strength

Layers 1-8 (Polyester) $CRC = 60\%$
 Short term strength: 12400 lb/ft (b)
 Creep limited strength: 7316 lb/ft (c)
 Design strength: 6097 lb/ft (d)
Layers 9-16 (Polypropylene) $CRC = 40\%$
 Short term strength: 6133 lb/ft
 Creep limited strength: 2453 lb/ft
 Design strength: 2044 lb/ft
Layers 17-25 (Polypropylene) $CRC = 40\%$
 Short term strength: 4133 lb/ft
 Creep limited strength: 1653 lb/ft
 Design strength: 1377 lb/ft
Layers 26-33 (Polypropylene) $CRC = 40\%$
 Short term strength: 2066 lb/ft
 Creep limited strength: 827 lb/ft
 Design Strength: 1377 lb/ft

Confining Soil Properties (f)

Unit Weight: 130 lb/ft³
 Friction Angle: 36°

Surcharge(a)

Sloped (2:1) fill 17 ft above the top of the wall

Schedule (a)

Activity	Mar-89	May-89	90	May-90
Construction				
Monitoring				
Demolition				

Notes

- a) Excerpted from the paper entitled "Performance of a 12.6 m high geotextile wall in Seattle, Washington", (Allen, 1992).
- b) Short term strength determined from the wide width tensile strength test (ASTM D-4565).
- c) Long term strength is determined by multiplying the short term strength by the creep reduction coefficient.
- d) The design strength is determined by dividing the long term strength by the factor of safety.
- e) The factor of safety accounts for internal stability (Allen, 1992).
- f) Estimated unit weight and friction angle used for design. Actual unit weight was 134 lb/ft³ and the friction angle varied from 43° to 47° (Allen, 1992).

Appendix B
Conservatism Index
Calculation Brief

Purpose:

The purpose of this calculation brief is to determine the conservatism index (CI) for the selected projects.

Methodology:

The CI value is computed using a limit equilibrium analysis where resisting lateral force provided by tensile strength of the reinforcement is divided by the driving lateral force of the earth. The CI value is based on the same principles of limit equilibrium used in the current design methods where the resisting tensile force is entirely provided by the reinforcement and redistribution of stresses due to the soil/geosynthetic interaction are ignored.

The CI value is based on the average lateral force (F) acting on the reinforcement layers assuming a linear Rankine active pressure distribution. The CI value is computed by dividing the short-term tensile strength of the reinforcement by the average lateral earth pressure acting on the wall. If the wall has different reinforcement spacings or strengths, a weighted CI value is computed. The computation is illustrated below followed by a summary of the results and detailed computation for each selected project.

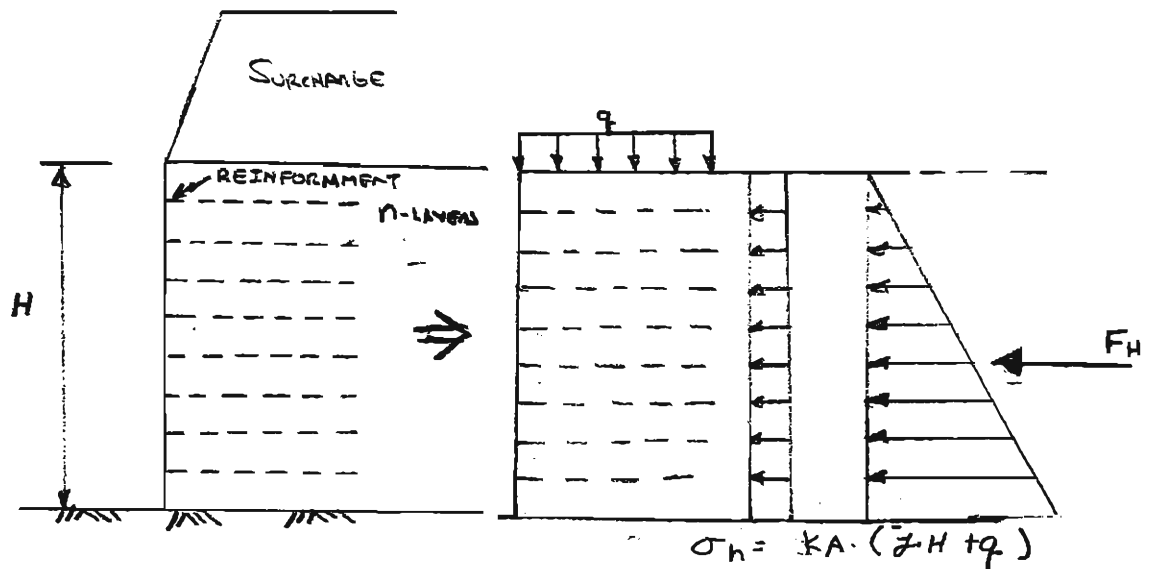

$$F_H = K_A \cdot (\frac{1}{2} \cdot H^2 \cdot 0.5 + q \cdot H) = \text{TOTAL FORCE ACTING ON WALL}$$

$$F_{AVG} = \frac{F_H}{N \text{ LAYERS}} = \text{AVERAGE FORCE ACTING ON WALL}$$

$$CI = \frac{T_{ULT}}{F_{AVG}} = \text{CONSERVATISM INDEX WHERE } T_{ULT} = \text{SHORT-TERM STRENGTH OF REINFORCEMENT}$$

Results

Project	Wall Name	Height (ft)	n	ϕ (deg)	γ lb/ft ³	q lb/ft ²	Ka	CI
Interstate Highway 70 through Glenwood Canyon	Geotextile Earth Retaining Wall	16	17	35	130	1950	0.27	0.44
Tanque Verde-Wrightstown-Pantano Roads	Wall Panel 26-30	15.6	10	34	122.5	359	0.28	8.7
	Wall Panel 26-30	16.1	10	34	122.5	359	0.28	8.1
Norwegian Geotechnical Institute	Wall Section J	15.7	4	38	108.8	1044	0.47	0.4
	Wall Section N	15.7	7	38	108.8	1044	0.47	1.8
Japanese Railway Test Embankment	JR Embankment No. 1	16.4	16	35 (a)	93.2	0	0.27	3.5
Highbury Avenue	Highbury Ave. Wall	23.3	9	35 (a)	125 (a)	0	0.27	8.2
Federal Highway Administration	Wall No. 9	20	8	39	125.6	728.6	0.23	7.9
Seattle Preload Fill	Southeast Wall	41.3	33	36	130	2210	0.26	2.6

Legend

n = Number of reinforcement layers

ϕ = Design internal friction angle

γ = Design unit weight

q = Surcharge

Ka = Active lateral earth pressure coefficient

CI = Conservatism Index

Notes

a) Value estimated since not available in the literature.

Interstate Highway 70 through Glenwood Canyon Project

Properties:

$H := 16\text{-ft}$ $H_q := 15\text{-ft}$ Height of Surcharge
 $\phi := 35\text{-deg}$ $\gamma_q := 130 \frac{\text{lb}}{\text{ft}^3}$ Assumed unit weight of surcharge
 $\gamma := 130 \frac{\text{lb}}{\text{ft}^3}$ $q := H_q \cdot \gamma_q$ $q = 1.95 \cdot 10^3 \cdot \text{lb} \cdot \text{ft}^{-2}$

Average lateral forces for each group with same reinforcement strength:

$K_a := \tan\left(45\text{-deg} - \frac{\phi}{2}\right)^2$ Number of layers and reinforcement each group:
 $K_a = 0.27$ $n_1 := 9$ $n_2 := 5$ $n_3 := 3$

Group 1:

$FH_1 := K_a \cdot [0.5 \cdot \gamma \cdot (9.5\text{-ft})^2 + q \cdot (9.5\text{-ft})]$

$FH_{1\text{avg}} := \frac{FH_1}{n_1}$

$FH_{1\text{avg}} = 734.42 \cdot \text{lb} \cdot \text{ft}^{-1}$

Average Lateral force
for group 1

Group 2:

$FH_2 := FH_1 + K_a \cdot [0.5 \cdot \gamma \cdot (4.3\text{-ft})^2 + q \cdot (4.3\text{-ft})]$

$FH_{2\text{avg}} := \frac{FH_2}{n_2}$

$FH_2 = 9.21 \cdot 10^3 \cdot \text{lb} \cdot \text{ft}^{-1}$

Average Lateral force
for group 2

Group 3:

$FH_3 := FH_2 + K_a \cdot [0.5 \cdot \gamma \cdot (2.2\text{-ft})^2 + q \cdot (2.2\text{-ft})]$

$FH_{3\text{avg}} := \frac{FH_3}{n_3}$

$FH_{3\text{avg}} = 3.49 \cdot 10^3 \cdot \text{lb} \cdot \text{ft}^{-1}$

Average Lateral force
for group 3

NOTE: SECTION 8
WORST CASE.
SEE APPENDIX A

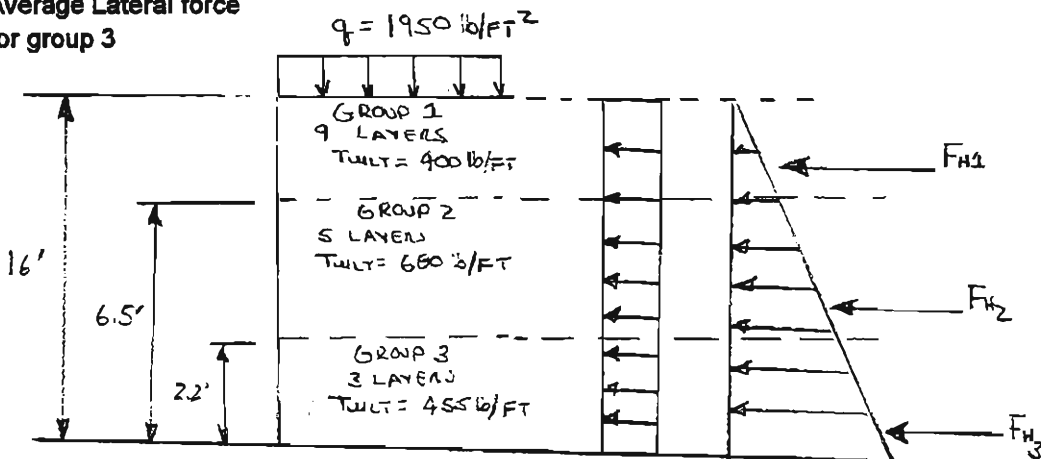

Conservatism index for each group

Reinforcement strength for each group:

$$T_{ult1} := 400 \cdot \frac{\text{lb}}{\text{ft}} \quad T_{ult2} := 680 \cdot \frac{\text{lb}}{\text{ft}}$$

$$CI1 := \frac{T_{ult1}}{FH1_{avg}} \quad CI1 = 0.54$$

$$CI2 := \frac{T_{ult2}}{FH2_{avg}} \quad CI2 = 0.37$$

$$T_{ult3} := 455 \cdot \frac{\text{lb}}{\text{ft}}$$

$$CI3 := \frac{T_{ult3}}{FH3_{avg}} \quad CI3 = 0.13$$

Weighted CI value

$$CI := \frac{9.5 \cdot \text{ft}}{16 \cdot \text{ft}} \cdot CI1 + \frac{4.3 \cdot \text{ft}}{16 \cdot \text{ft}} \cdot CI2 + \frac{2.2 \cdot \text{ft}}{16 \cdot \text{ft}} \cdot CI3$$

CI = 0.44 CI = 0.44 for Interstate Highway 70 through Glenwood Canyon Project

Tanque Verde - Wrightstown - Pantano - Roads

Project Wall Panel 26-30

Properties:

$$\phi := 34 \cdot \text{deg} \quad T_{ult} := 5400 \cdot \frac{\text{lb}}{\text{ft}}$$

$$\gamma := 122.5 \cdot \frac{\text{lb}}{\text{ft}^3} \quad q := 359 \cdot \frac{\text{lb}}{\text{ft}^2}$$

Average lateral forces for each group with same reinforcement strength:

$$K_a := \tan \left(45 \cdot \text{deg} - \frac{\phi}{2} \right)^2$$

Number of layers and reinforcement each group:

$$n1 := 5 \quad n2 := 5$$

$$K_a = 0.28$$

$$FH1 := K_a \cdot \left[0.5 \cdot \gamma \cdot (10.1 \cdot \text{ft})^2 + q \cdot (10.1 \cdot \text{ft}) \right]$$

$$FH1_{avg} := \frac{FH1}{n1}$$

$$FH1_{avg} = 558.31 \cdot \text{lb} \cdot \text{ft}^{-1}$$

Average Lateral force
for group 1

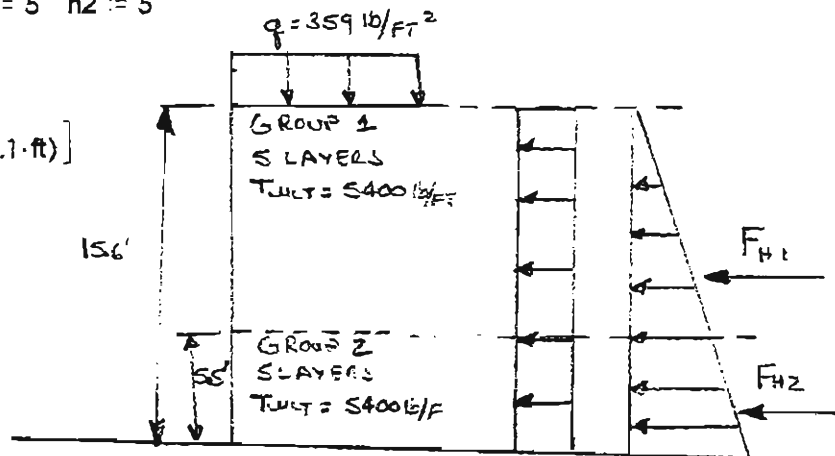

Group 2:

$$FH2 := FH1 + Ka \cdot [0.5 \cdot \gamma \cdot (5.5 \cdot ft)^2 + q \cdot (5.5 \cdot ft)]$$

$$FH2_{avg} := \frac{FH2}{n2}$$

$$FH2 = 3.87 \cdot 10^3 \cdot lb \cdot ft^{-1}$$

Average Lateral force
for group 2

Conservatism index for each group

$$CI1 := \frac{T_{ult}}{FH1_{avg}} \quad CI1 = 9.67$$

$$CI2 := \frac{T_{ult}}{FH2_{avg}} \quad CI2 = 6.97$$

Weighted CI value

$$CI := \frac{10.1 \cdot ft}{15.6 \cdot ft} \cdot CI1 + \frac{5.5 \cdot ft}{15.6 \cdot ft} \cdot CI2$$

CI = 8.72 CI = 8.72 for the Tanque Verde - Wrightstown - Pantano Roads Project
Wall Panel 26-30

Tanque Verde - Wrightstown - Pantano - Roads
Project Wall Panel 26-32

$$FH1 := Ka \cdot [0.5 \cdot \gamma \cdot (10.6 \cdot ft)^2 + q \cdot (10.6 \cdot ft)]$$

$$FH1_{avg} := \frac{FH1}{n1}$$

$$FH1_{avg} = 604.3 \cdot lb \cdot ft^{-1}$$

Average Lateral force
for group 1

$$FH2 := FH1 + Ka \cdot [0.5 \cdot \gamma \cdot (5.5 \cdot ft)^2 + q \cdot (5.5 \cdot ft)]$$

$$FH2_{avg} := \frac{FH2}{n2}$$

Average Lateral force
for group 2

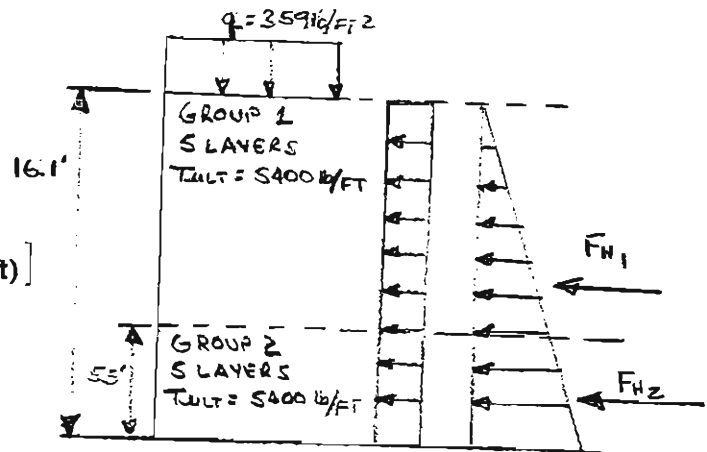

$$CI1 := \frac{Tult}{FH1avg} \quad CI1 = 8.94$$

$$CI2 := \frac{Tult}{FH2avg}$$

Weighted CI value

$$CI := \frac{10.1 \cdot ft}{15.6 \cdot ft} \cdot CI1 + \frac{5.5 \cdot ft}{15.6 \cdot ft} \cdot CI2$$

CI = 8.11 **CI = 8.1 for the Tanque Verde - Wrightstown - Pantano Roads Project Wall Panel 26-32**

Norwegian Geotechnical Institute Project Section 'N'

Properties:

$$\begin{aligned} \phi &:= 38 \text{-deg} & Tult &:= 3600 \cdot \frac{lb}{ft} & B &:= 26.6 \text{-deg} & \text{Sloped face} \\ \gamma &:= 108.8 \cdot \frac{lb}{ft^3} & q &:= 1044 \cdot \frac{lb}{ft^2} & n &:= 7 & \text{Reinforced layers spaced evenly} \end{aligned}$$

Average lateral forces for each group with same reinforcement strength:

$$Ka := \frac{\cos(\phi - B)^2}{\cos(B)^2 \cdot \cos(B) \cdot \left[1 + \left(\frac{\sin(\phi) \cdot \sin(\phi)}{\cos(B) \cdot \cos(B)} \right)^{.5} \right]^2} \quad Ka = 0.47$$

$$FH1 := Ka \cdot \left[.5 \cdot \gamma \cdot (15.7 \cdot ft)^2 + q \cdot (15.7 \cdot ft) \right]$$

$$FH1avg := \frac{FH1}{n}$$

$$FH1avg = 2.01 \cdot 10^3 \cdot lb \cdot ft^{-1}$$

Average Lateral force

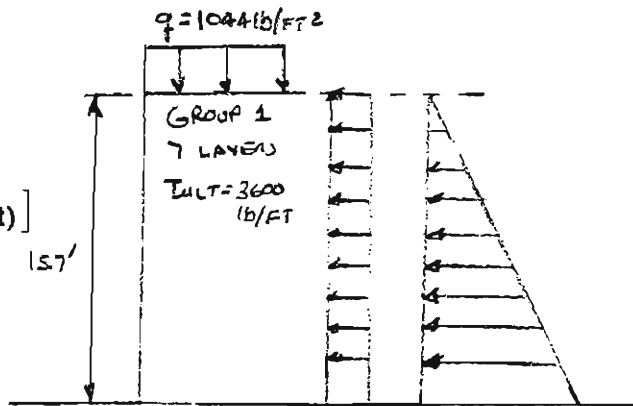

Conservatism index

$$CI := \frac{Tult}{FH1avg} \quad CI = 1.79$$

CI = 1.8 for the Norwegian Geotechnical Institute Project Section 'N'

Properties:

$$\phi := 38\text{-deg} \quad T_{ult} := 3600 \cdot \frac{\text{lb}}{\text{ft}} \quad B := 26.6\text{-deg} \quad \text{Sloped face}$$

$$\gamma := 108.8 \cdot \frac{\text{lb}}{\text{ft}^3} \quad q := 1044 \cdot \frac{\text{lb}}{\text{ft}^2}$$

Average lateral forces for each group with same reinforcement strength:

$$K_a := \frac{\cos(\phi - B)^2}{\cos(B)^2 \cdot \cos(B) \cdot \left[1 + \left(\frac{\sin(\phi) \cdot \sin(\phi)}{\cos(B) \cdot \cos(B)} \right)^{.5} \right]^2} \quad K_a = 0.47$$

n1 := 2 reinforcement layers in group 1

n2 := 2 reinforcement layers in group 2

$$FH1 := K_a \cdot \left[.5 \cdot \gamma \cdot (11.2 \cdot \text{ft})^2 + q \cdot (11.2 \cdot \text{ft}) \right]$$

$$FH1_{avg} := \frac{FH1}{n1}$$

$FH1_{avg} = 4.36 \cdot 10^3 \cdot \text{lb} \cdot \text{ft}^{-1}$ Average Lateral force for group 1

$$FH2 := FH1 + K_a \cdot \left[.5 \cdot \gamma \cdot (4.5 \cdot \text{ft})^2 + q \cdot (4.5 \cdot \text{ft}) \right]$$

$$FH2_{avg} := \frac{FH2}{n2}$$

$FH1_{avg} = 4.36 \cdot 10^3 \cdot \text{lb} \cdot \text{ft}^{-1}$ Average Lateral force for group 2

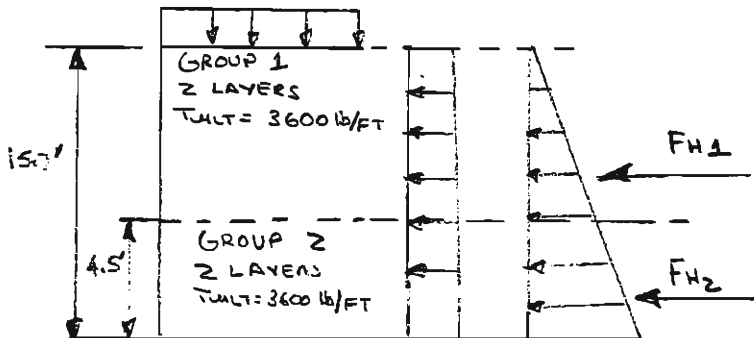

Weighted CI value

$$CI1 := \frac{Tult}{FH1} \quad CI1 = 0.41 \quad CI2 := \frac{Tult}{FH2} \quad CI2 = 0.31$$

$$CI := \frac{11.2 \cdot ft}{15.7 \cdot ft} \cdot CI1 + \frac{4.5 \cdot ft}{15.7 \cdot ft} \cdot CI2$$

CI = 0.38 **CI = .4 for the Norwegian Geotechnical Institute Project Wall Section 'N'**

Japanese Railway Test Embankment Project

Properties:

$$\phi := 35 \cdot \text{deg} \quad \text{Assumed} \quad Tult := 1880 \cdot \frac{lb}{ft}$$

$$\gamma := 93.2 \cdot \frac{lb}{ft^3} \quad n := 16 \text{ Reinforced layers spaced evenly}$$

Average lateral forces for each group with same reinforcement strength:

$$Ka := \tan \left(45 \cdot \text{deg} - \frac{\phi}{2} \right)^2$$

$$Ka = 0.27$$

$$FH := Ka \cdot \left[.5 \cdot \gamma \cdot (16.4 \cdot ft)^2 \right]$$

$$FH_{avg} := \frac{FH}{n}$$

$$FH_{avg} = 545.6 \cdot lb \cdot ft^{-1}$$

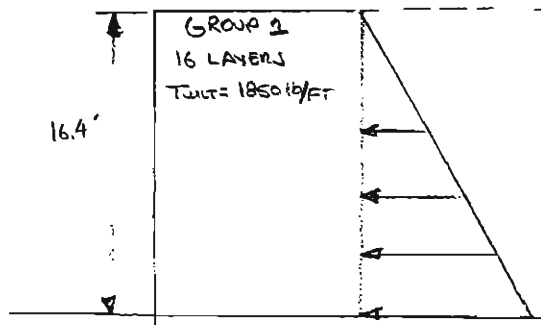

CI Value

$$CI := \frac{Tult}{FH_{avg}} \quad CI = 3.45 \quad \text{CI} = 3.5 \text{ for the Japanese Railway Test Embankment Project}$$

Highbury Avenue Project

Properties:

$$\phi := 35 \cdot \text{deg} \quad Tult := 2000 \cdot \frac{lb}{ft}$$

$$\gamma := 125 \cdot \frac{lb}{ft^3} \quad \text{Assumed}$$

LATERAL FORCES

$$K_a := \tan \left(45 \cdot \text{deg} - \frac{\phi}{2} \right)^2$$

$$K_a = 0.27$$

Number of layers and reinforcement each group:

n1 := 5 Number of reinforcement layers in group 1

n2 := 4 Number of reinforcement layers in group 2

$$FH1 := K_a \cdot [0.5 \cdot \gamma \cdot (16.3 \cdot \text{ft})^2]$$

$$FH1_{\text{avg}} := \frac{FH1}{n1}$$

FH1avg = 899.99 · lb · ft⁻¹ Average Lateral force for group 1

Group 2:

$$FH2 := FH1 + K_a \cdot [0.5 \cdot \gamma \cdot (7 \cdot \text{ft})^2]$$

$$FH2_{\text{avg}} := \frac{FH2}{n2}$$

$$FH2_{\text{avg}} = 1.33 \cdot 10^3 \cdot \text{lb} \cdot \text{ft}^{-1}$$

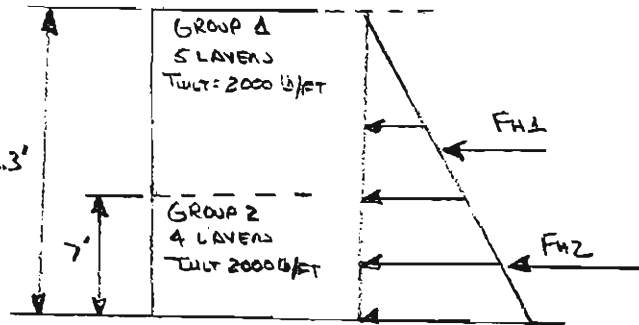

Weighted CI value

$$CI := \frac{16.3 \cdot \text{ft}}{23.3 \cdot \text{ft}} \cdot CI1 + \frac{7 \cdot \text{ft}}{23.3 \cdot \text{ft}} \cdot CI2$$

CI = 8.23 CI = 8.2 for the Highway Avenue Project

Federal Highway Administration Research Project

Properties:

$$\phi := 39 \cdot \text{deg} \quad T_{ult} := 2604 \cdot \frac{\text{lb}}{\text{ft}} \quad \gamma_q := 105.6 \cdot \frac{\text{lb}}{\text{ft}^3} \quad \text{Unit weight of surcharge}$$

$$\gamma := 125.6 \cdot \frac{\text{lb}}{\text{ft}^3} \quad H_q := 6.9 \cdot \text{ft} \quad \text{Height of surcharge}$$

$$q := \gamma_q \cdot H_q \quad q = 728.64 \cdot \text{lb} \cdot \text{ft}^{-2} \quad \text{Surcharge}$$

LATERAL FORCES

$$K_a := \tan\left(45 \cdot \text{deg} - \frac{\phi}{2}\right)^2$$

$$K_a = 0.23$$

Number of layers and reinforcement each group:

$$n1 := 5$$

$$n2 := 3$$

Group 1:

$$FH1 := K_a \cdot [0.5 \cdot \gamma \cdot (11 \cdot \text{ft})^2 + q \cdot 11 \cdot \text{ft}]$$

$$FH1_{\text{avg}} := \frac{FH1}{n1}$$

$FH1_{\text{avg}} = 710.45 \cdot \text{lb} \cdot \text{ft}^{-1}$ Average Lateral force for group 1

Group 2:

$$FH2 := FH1 + K_a \cdot [0.5 \cdot \gamma \cdot (9 \cdot \text{ft})^2 + q \cdot 9 \cdot \text{ft}]$$

$$FH2_{\text{avg}} := \frac{FH2}{n2}$$

$$FH2_{\text{avg}} = 2.07 \cdot 10^3 \cdot \text{lb} \cdot \text{ft}^{-1}$$

Weighted CI value

$$CI := \frac{11 \cdot \text{ft}}{20 \cdot \text{ft}} \cdot CI1 + \frac{9 \cdot \text{ft}}{20 \cdot \text{ft}} \cdot CI2$$

$CI = 7.88$ $CI = 7.9$ for the Federal Highway Administration Project

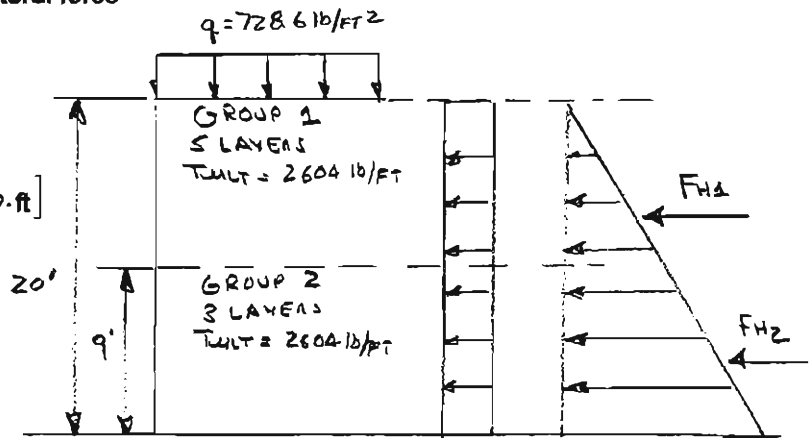

Seattle Preload Fill Project

Properties:

$$\phi := 36 \cdot \text{deg}$$

$$Hq := 17 \cdot \text{ft} \quad \text{Height of Surcharge}$$

$$\gamma := 130 \cdot \frac{\text{lb}}{\text{ft}^3}$$

$$\gamma q := 130 \cdot \frac{\text{lb}}{\text{ft}^3} \quad \text{Assumed unit weight of surcharge}$$

$$q := Hq \cdot \gamma q \quad q = 2.21 \cdot 10^3 \cdot \text{lb} \cdot \text{ft}^{-2}$$

Calculation Brief

Average lateral forces for each group with same reinforcement strength:

$$K_a := \tan\left(45\text{-deg} - \frac{\phi}{2}\right)^2$$

$$K_a = 0.26$$

Number of layers and reinforcement each group:

$$n_1 := 8 \quad n_2 := 9 \quad n_3 := 8 \quad n_4 := 8$$

Group 1:

$$FH_1 := K_a \cdot \left[0.5 \cdot \gamma \cdot (11.3\text{-ft})^2 + q \cdot (11.3\text{-ft}) \right]$$

$$FH_{1avg} := \frac{FH_1}{n_1}$$

$$FH_{1avg} = 1.08 \cdot 10^3 \cdot \text{lb} \cdot \text{ft}^{-1}$$

Average Lateral force
for group 1

Group 2:

$$FH_2 := FH_1 + K_a \cdot \left[0.5 \cdot \gamma \cdot (10\text{-ft})^2 + q \cdot (10\text{-ft}) \right]$$

$$FH_{2avg} := \frac{FH_2}{n_2}$$

$$FH_2 = 1.61 \cdot 10^4 \cdot \text{lb} \cdot \text{ft}^{-1}$$

Average Lateral force
for group 2

Group 3:

$$FH_3 := FH_2 + K_a \cdot \left[0.5 \cdot \gamma \cdot (10\text{-ft})^2 + q \cdot (10\text{-ft}) \right]$$

$$FH_{3avg} := \frac{FH_3}{n_3}$$

$$FH_{3avg} = 2.94 \cdot 10^3 \cdot \text{lb} \cdot \text{ft}^{-1}$$

Average Lateral force
for group 3

Group 4:

$$FH_4 := FH_2 + K_a \cdot \left[0.5 \cdot \gamma \cdot (10\text{-ft})^2 + q \cdot (10\text{-ft}) \right]$$

$$FH_{4avg} := \frac{FH_4}{n_4}$$

$$FH_{4avg} = 2.94 \cdot 10^3 \cdot \text{lb} \cdot \text{ft}^{-1}$$

Average Lateral force
for group 4

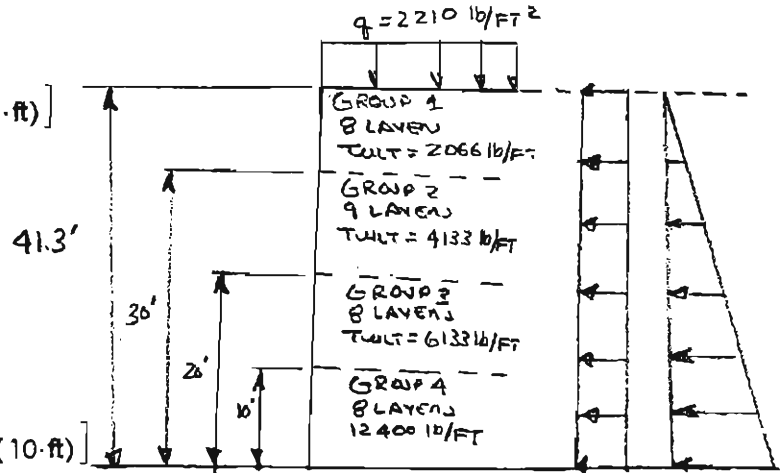

Reinforcement strength for each group:

$$Tult1 := 2066 \cdot \frac{\text{lb}}{\text{ft}} \quad Tult2 := 4133 \cdot \frac{\text{lb}}{\text{ft}} \quad Tult3 := 6133 \cdot \frac{\text{lb}}{\text{ft}} \quad Tult4 := 12400 \cdot \frac{\text{lb}}{\text{ft}}$$

$$CI1 := \frac{Tult1}{FH1avg} \quad CI1 = 1.91$$

$$CI2 := \frac{Tult2}{FH2avg} \quad CI2 = 2.32$$

$$CI3 := \frac{Tult3}{FH3avg} \quad CI3 = 2.09$$

$$CI4 := \frac{Tult4}{FH4avg} \quad CI4 = 4.22$$

Weighted CI value

$$CI := CI1 \cdot \frac{11.3 \cdot \text{ft}}{41.3 \cdot \text{ft}} + CI2 \cdot \frac{10 \cdot \text{ft}}{41.3 \cdot \text{ft}} + CI3 \cdot \frac{10 \cdot \text{ft}}{41.3 \cdot \text{ft}} + CI4 \cdot \frac{10 \cdot \text{ft}}{41.3 \cdot \text{ft}}$$

$$CI = 2.61 \quad CI = 2.6 \text{ for the Seattle Preload Fill Project}$$

Note: SEE APPENDIX A FOR PROJECT DESCRIPTIONS
AND REFERENCES.

Appendix C
Conservatism Index

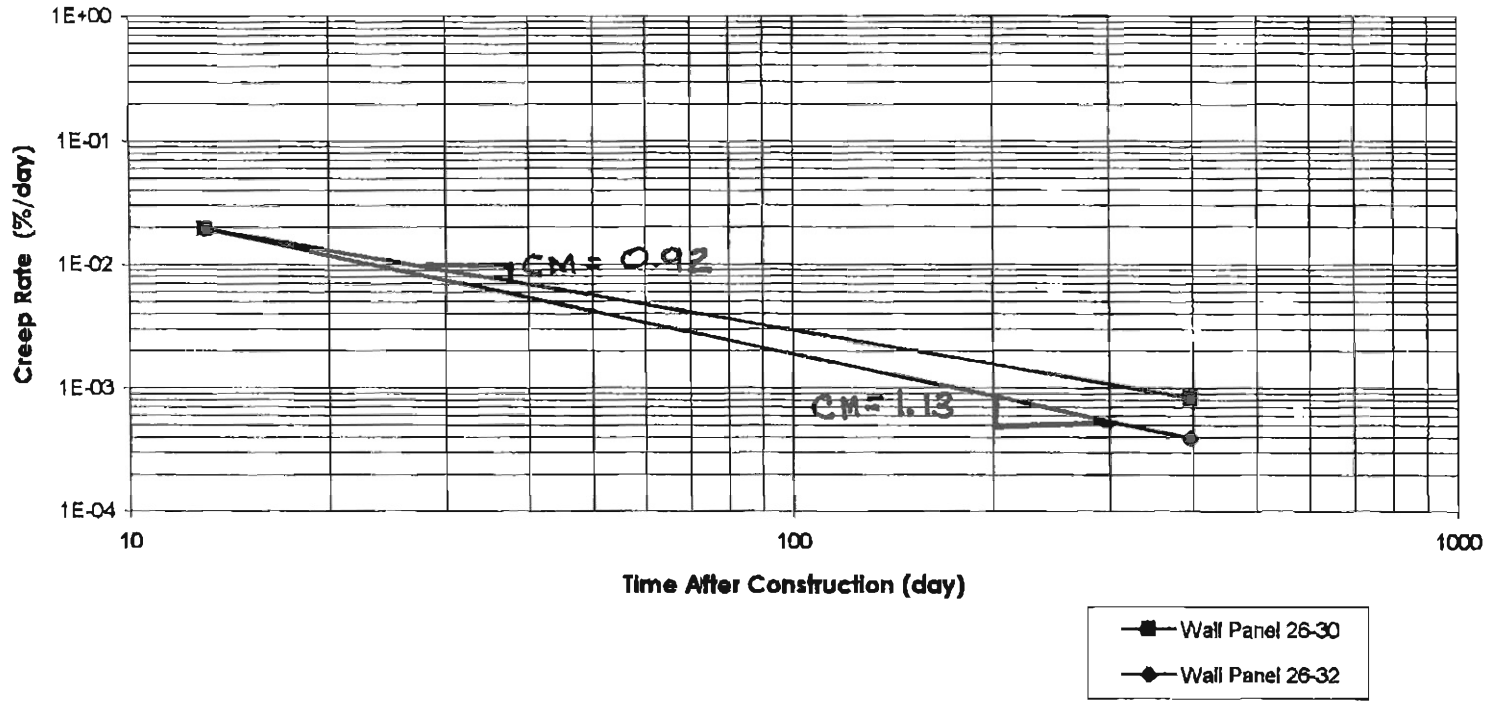

Figure C.1
Creep-Rate-Time Curve for the Tanque Verde - Wrightstown - Pantano Roads Project

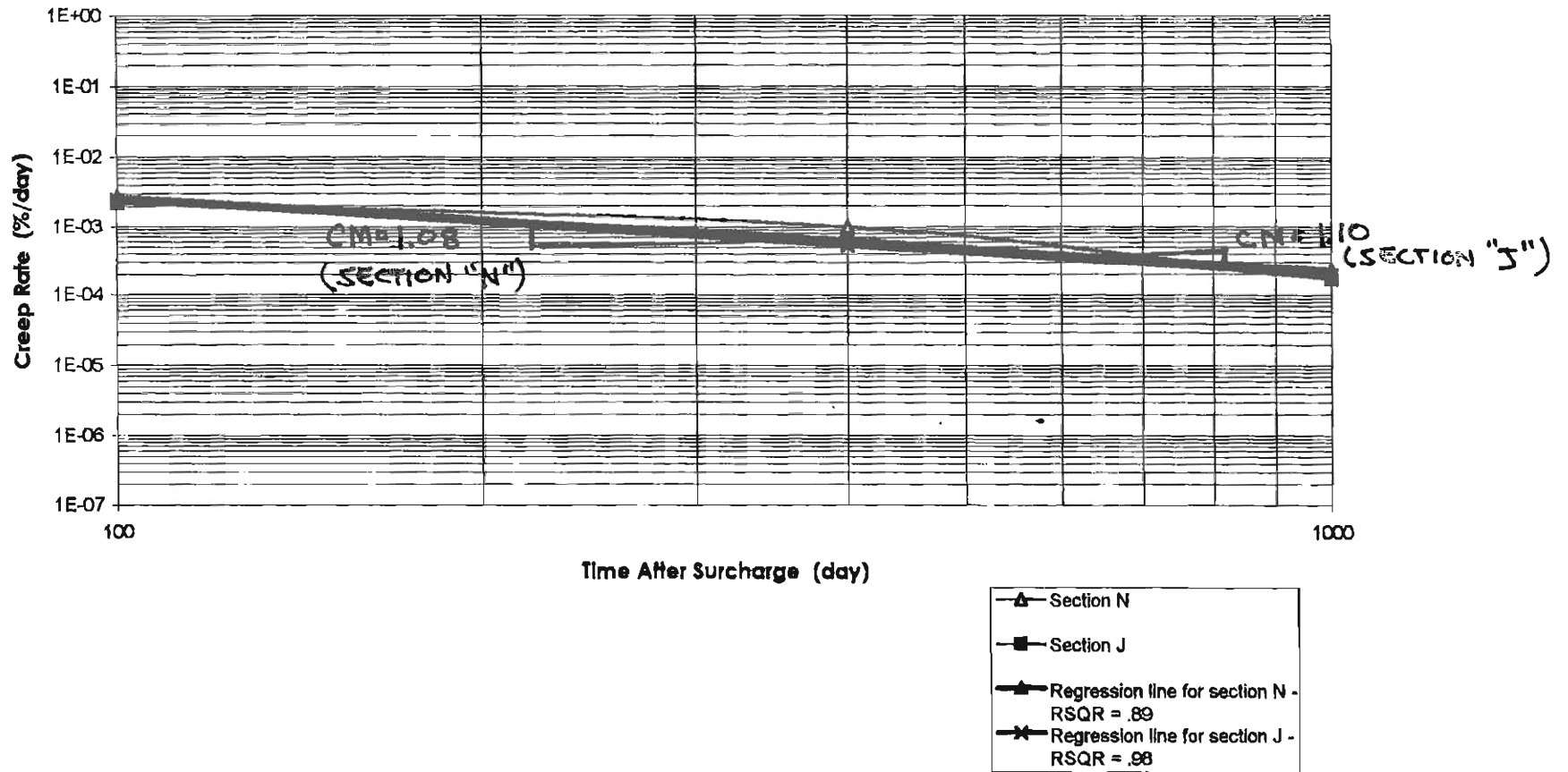

Figure C.2
Creep-Rate-Time Curve for the Nowegian Geotechnical Institute Project

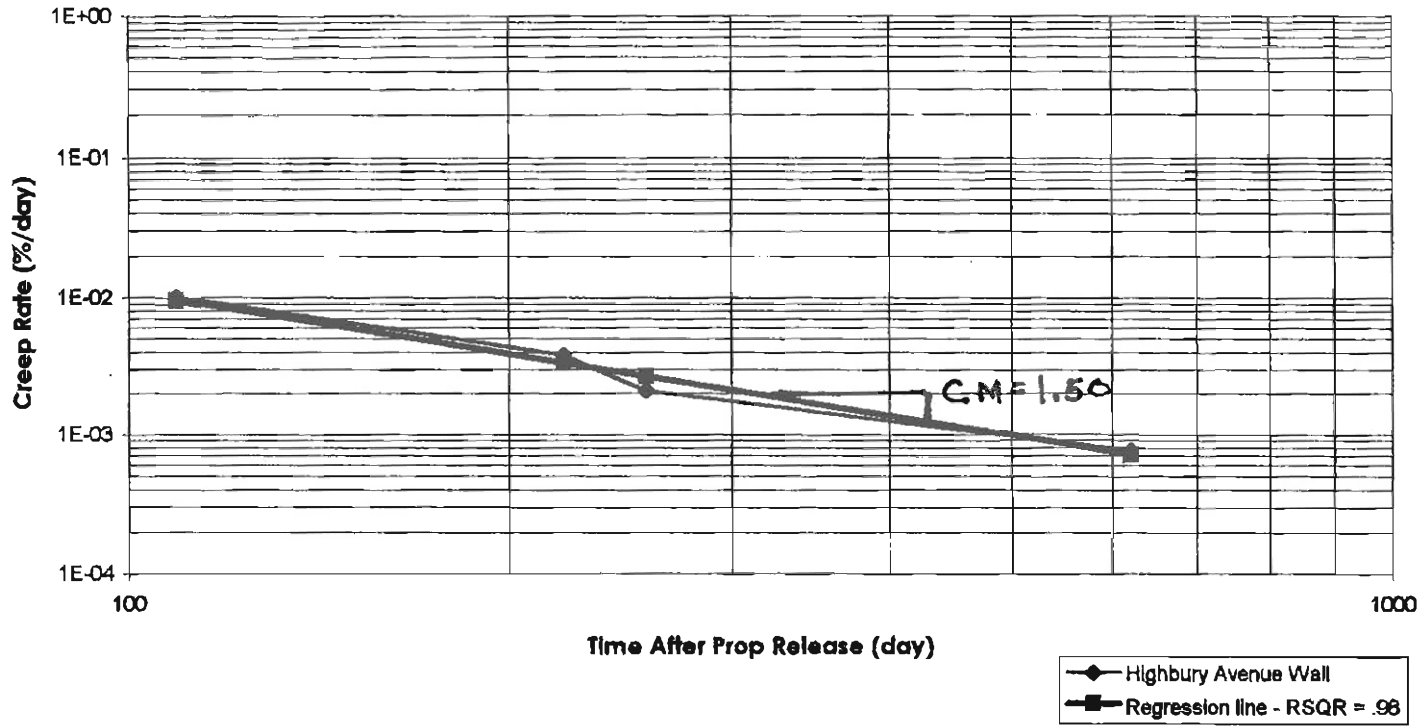

Figure C.3
Creep-Rate-Time Curve for the Highbury Avenue Project

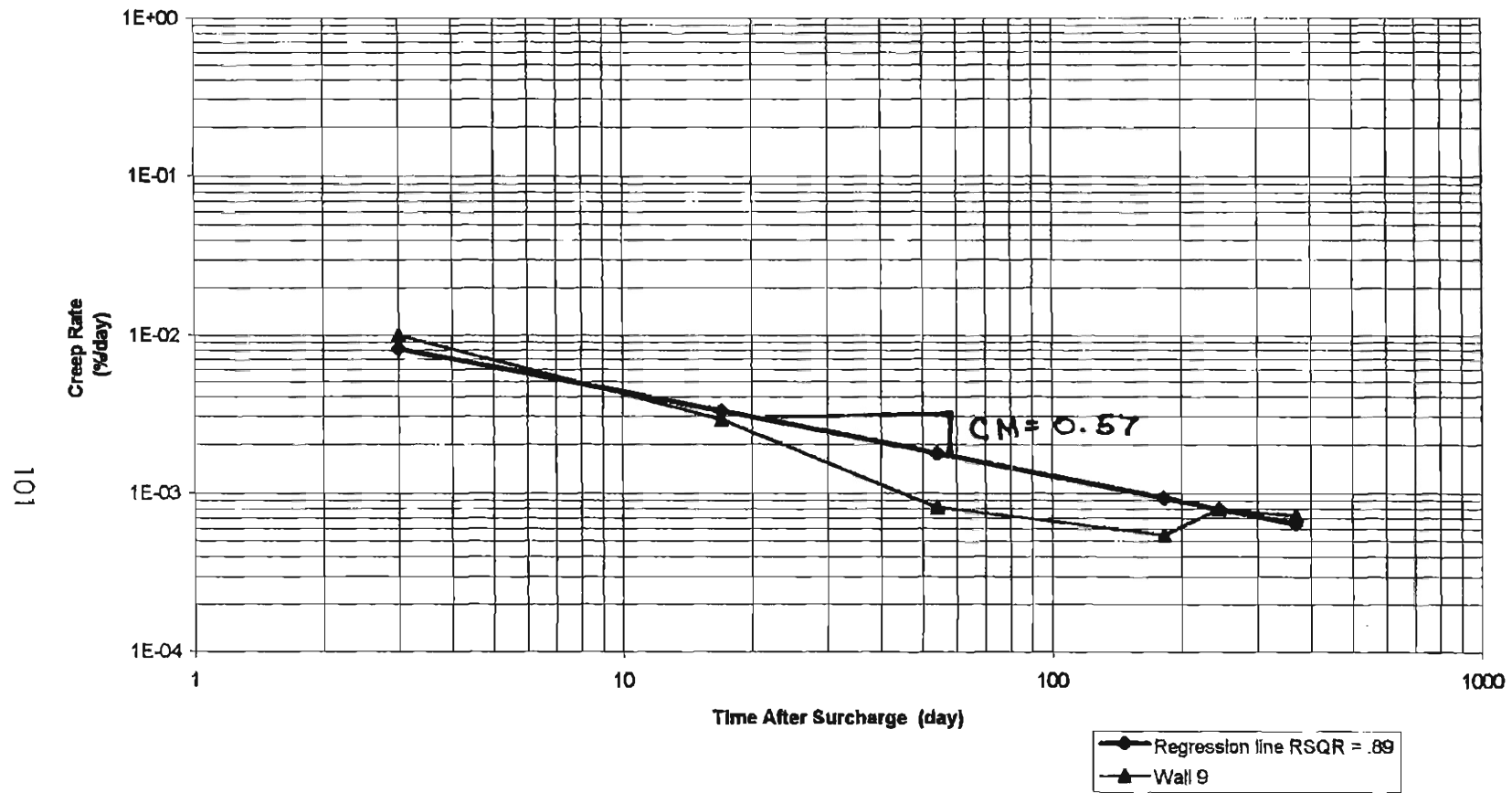

Figure C.4
Creep-Rate-Time Curve for the Federal Highway Administration Project

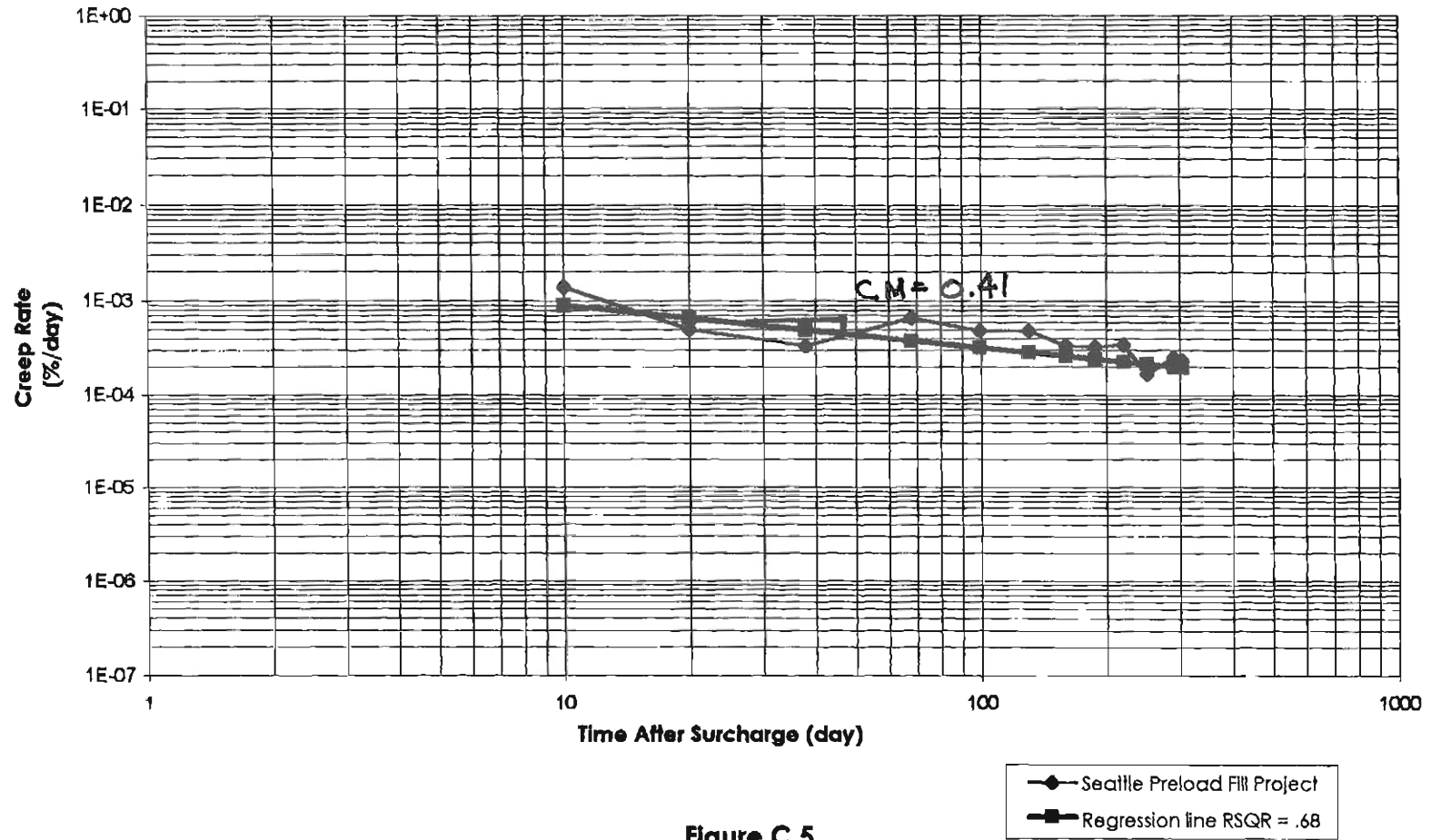

Figure C.5
Creep-Rate-Time Curve Seattle Preload Fill Project

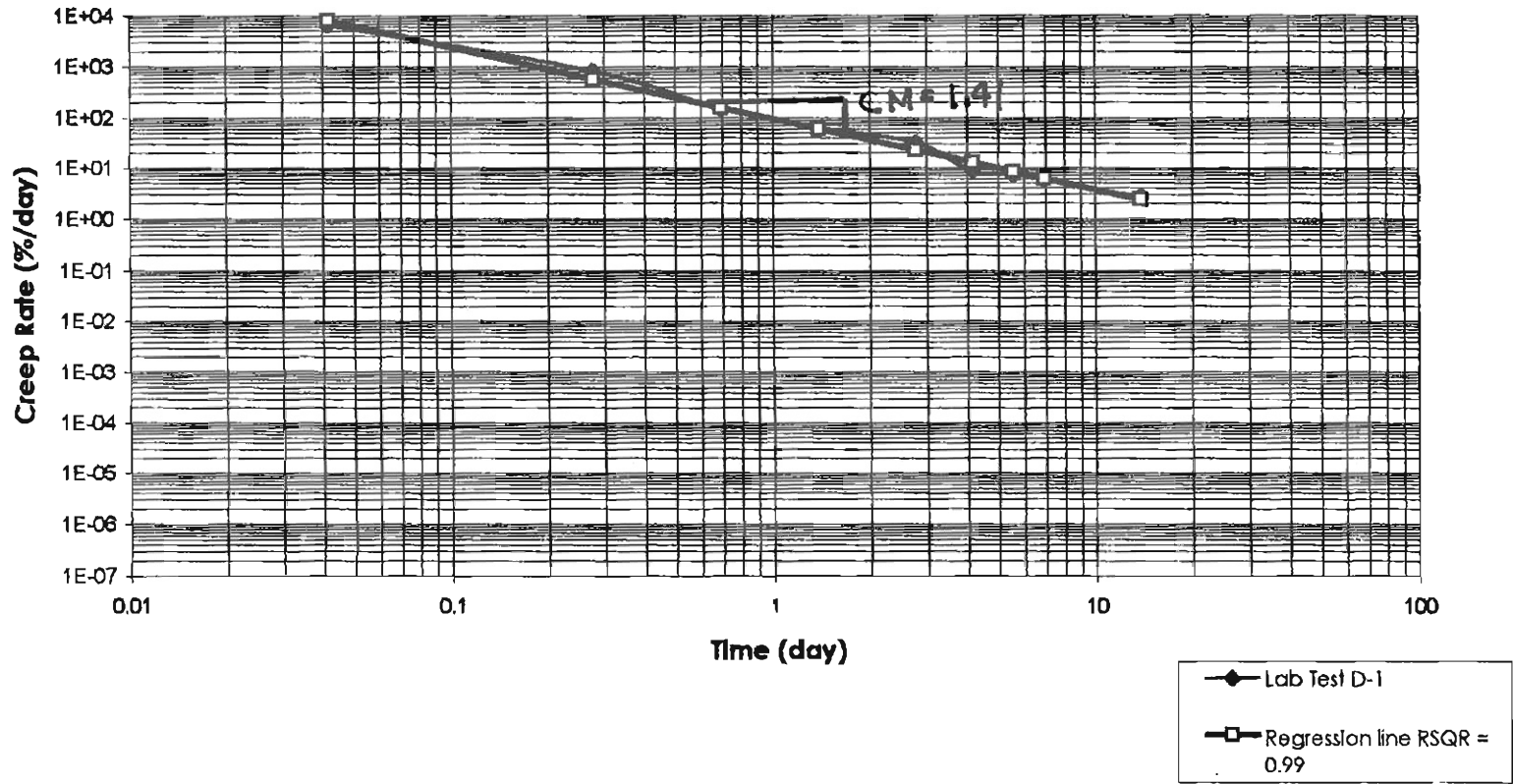

Figure C.6
Laboratory Creep Test D-1

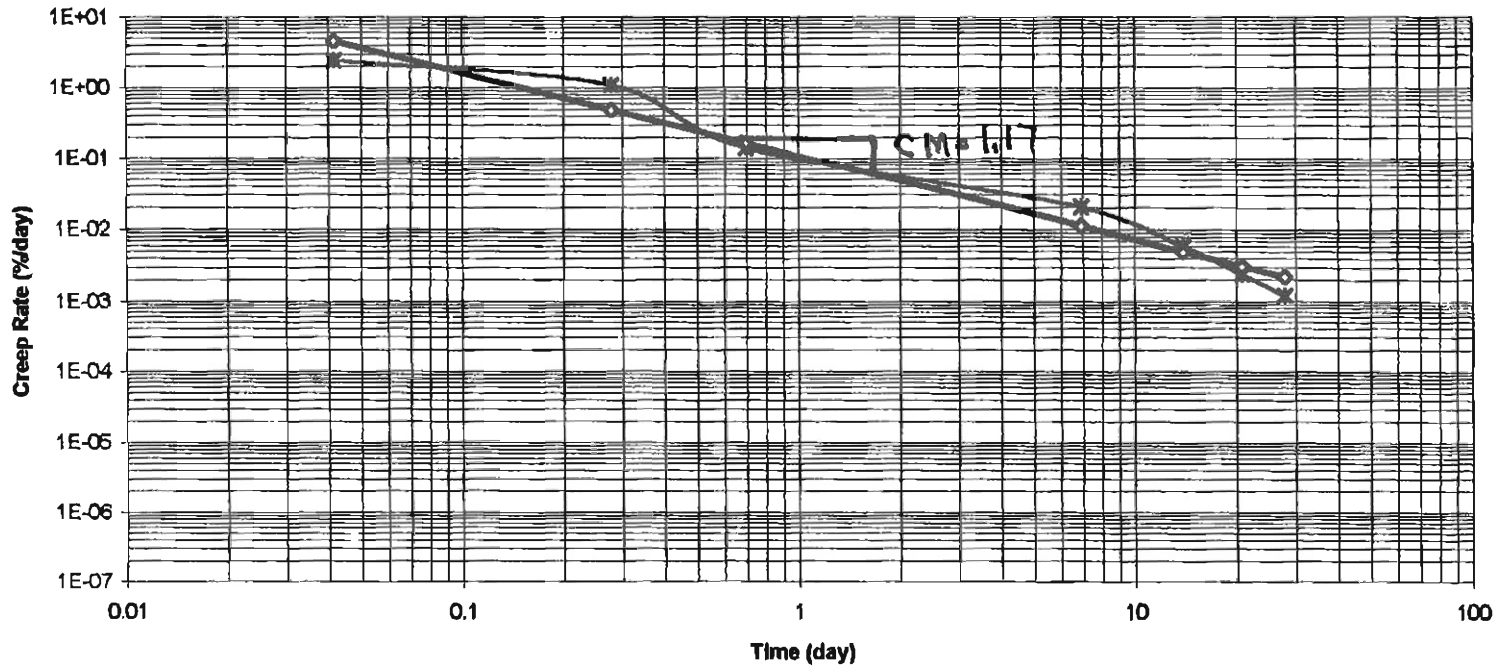
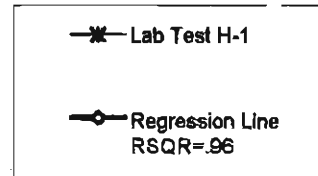

Figure C.7
Laboratory Creep Test H-1



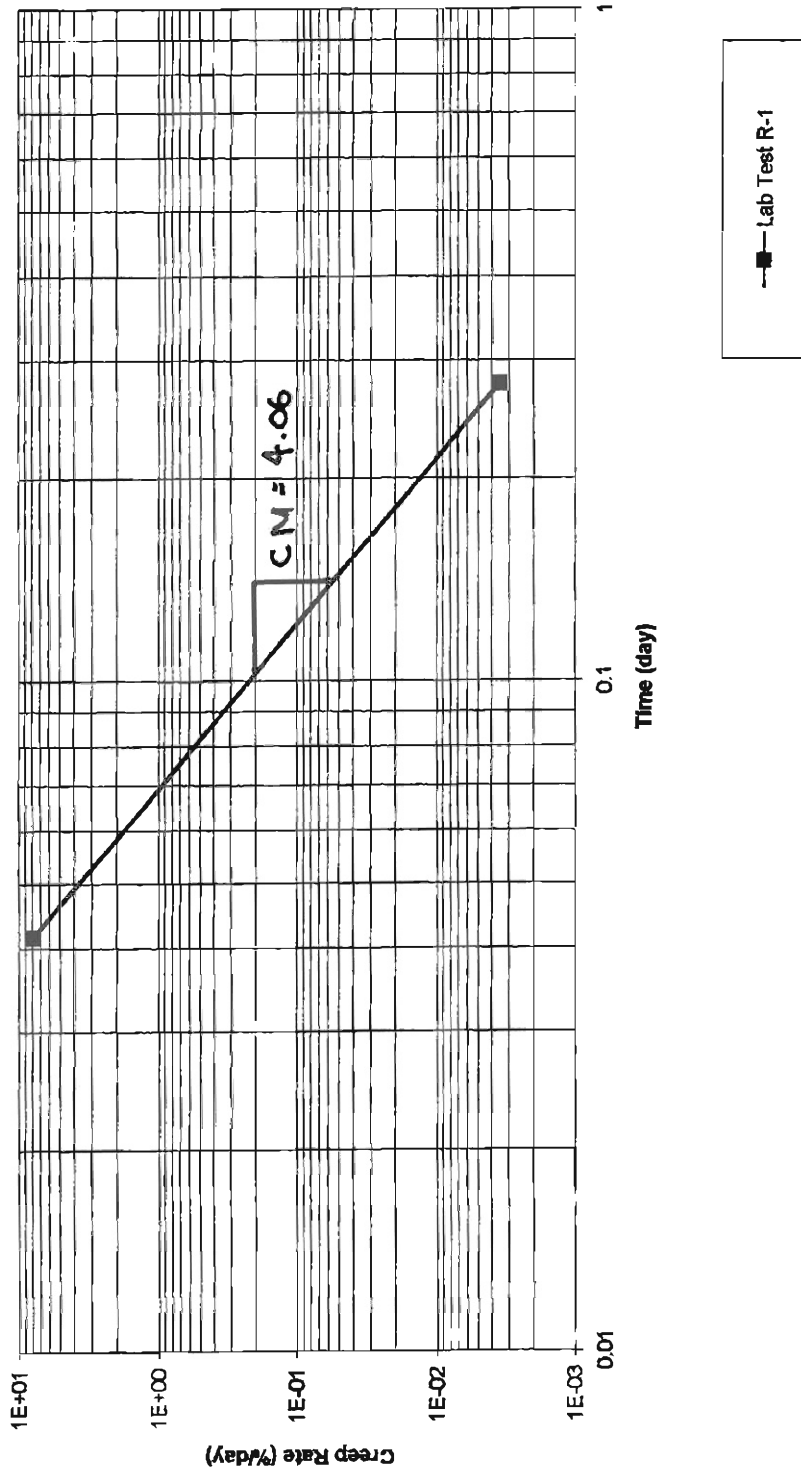

Figure C.8
Laboratory Creep Test R-1

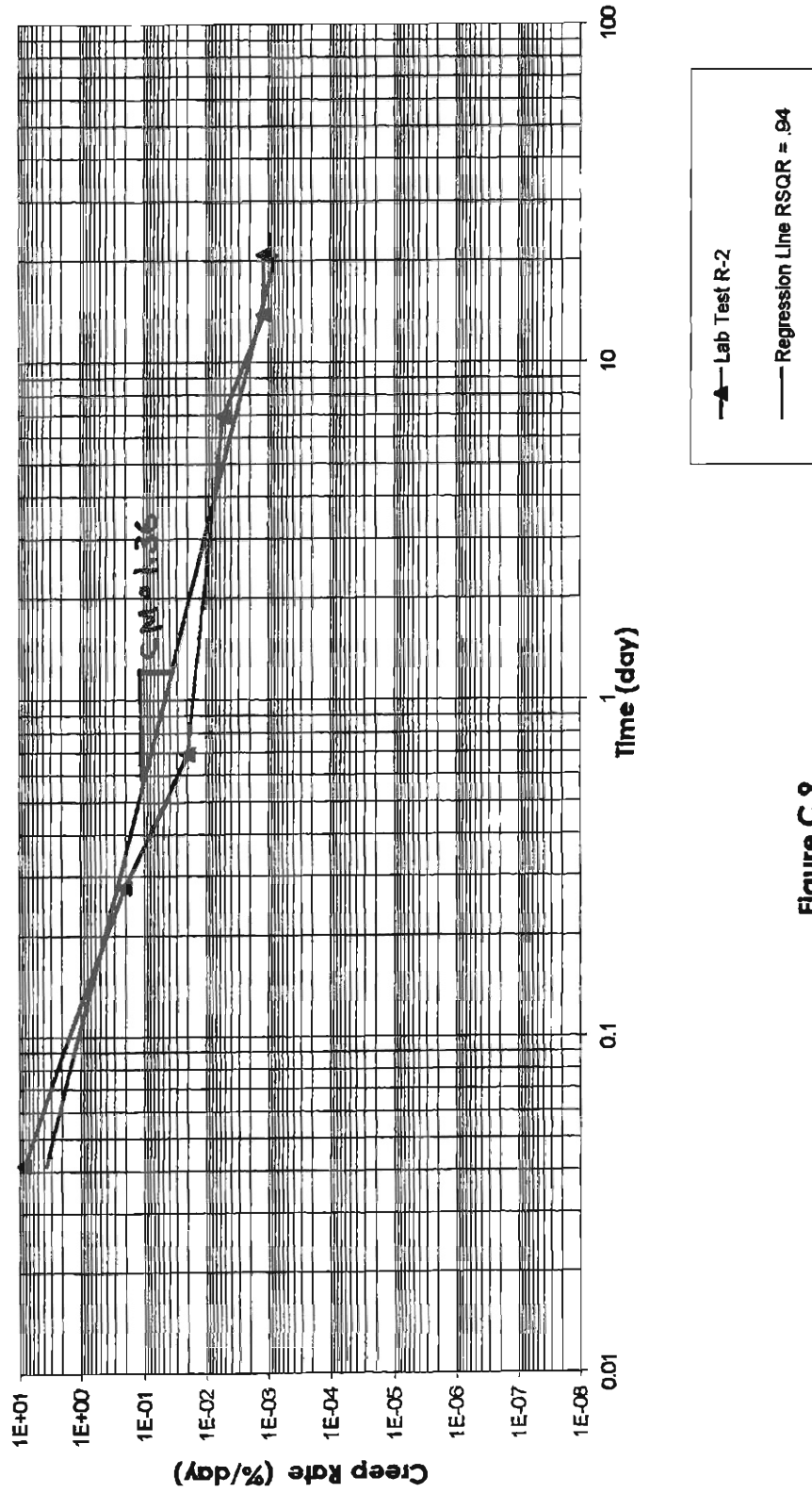

Figure C.9
Laboratory Test R-2

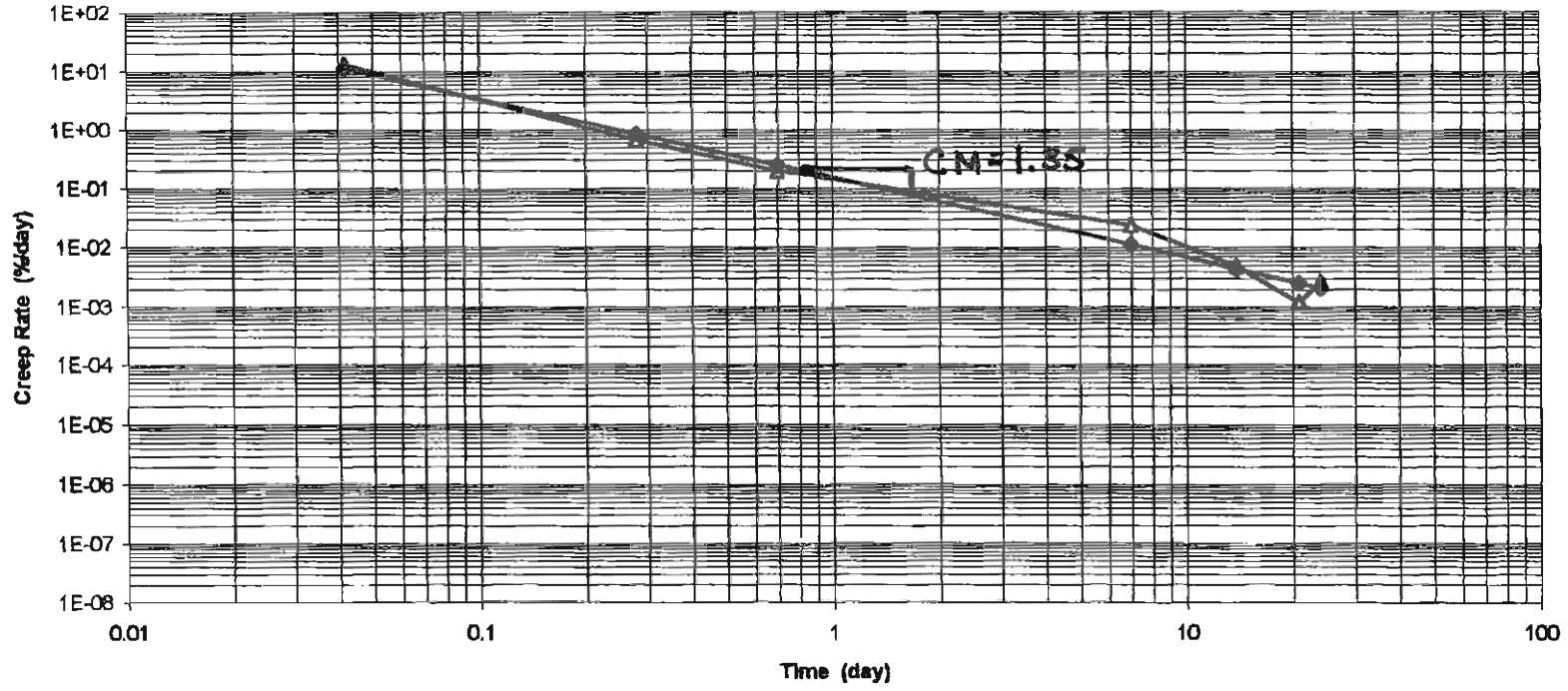
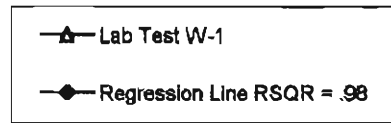

Figure C.10
Laboratory Creep Test W-1



References

- Allen T.M., Vinson T.S., and Bell, J.R. (1982). "Tensile Strength and Creep Behavior of Geotextiles in Cold Regions Applications", Proceedings of the 2nd International Conference on Geotextiles, Las Vegas, Vol. 3, August 1982, pp 775-780.
- Allen T.M., Christopher B.R., and Holtz R.D. (1992). "Performance of a 12.6 m High Geotextile Wall in Seattle, Washington", Geosynthetic-Reinforced Soil Retaining Walls. Ed. Jonathan T.H. Wu. A.A. Balkema Publishers, Rotterdam, Netherlands, pp. 81-100.
- AASHTO (1990). "In Situ Soil Improvement Techniques", Report on Task Force 27, Joint Subcommittee Report of AASHTO-AGC-ARTBA. American Association of State Highway and Transportation Officials, Washington, D.C.
- AASHTO (1992). "Standard Specifications for Highway Bridges", 15th edition, AASHTO Subcommittee on Bridges and Structure.
- ASTM D 4595. "Tensile Properties of Geotextiles by the Wide Width Strip Method", American Society for Testing and Materials, Philadelphia, PA.

Bathurst, R.J., and Simac M.R. (1991). "Review of Three Instrumented Geogrid Reinforced Soil Retaining Walls", Geosynthetics: Design and Performance, Vancouver Geotechnical Society - 6' th Annual, One Day Symposium, May.

Bathurst, R.J. (1992). "Case Study of a Monitored Propped Panel Wall", Geosynthetic-Reinforced Soil Retaining Walls. Ed. Jonathan T.H. Wu. A.A. Balkema Publishers, Rotterdam, Netherlands, pp. 159-166

Bell, J.R., Barrett, R.K. and Ruckman, A.C. (1983), "Geotextile Earth-Reinforced Retaining Wall Test: Glenwood Canyon, Colorado", Transportation Research Record 916, National Academy Press, Washington, D.C., pp. 59-69.

Bell, J.R. and Barrett, R.K. (1994) "Survivability and Durability of Geotextiles Buried in Glenwood Canyon Wall", Transportation Research Board Meeting Paper, Washington, D.C. January, 1994

Berg, R.R., Bonaparte, R., Anerson, R.P, and Chouery, V.E. (1986). "Design, Construction and Performance of Two Geogrid Reinforced Soil Retaining Walls", Proceedings from the Third International Conference on Geotextiles, Vienna, Austria, pp. 401-406.

Bright, D.G., Collins, C.G., and Berg, R.R. (1994). "Durability of Geosynthetic Soil Reinforcement Elements in Tanque Verde Retaining Wall Structures", Transportation Research Record No. 1439, National Academy Press, Washington, D.C., pp 46-54.

Christopher B.R., Bonczkiewicz C, and Holtz R.D. (1992). "Design, Construction and Monitoring of Full Scale Test of Reinforced Soil Walls and Slopes", Recent Case Histories of Permanent Geosynthetic-Reinforced Soil Retaining Walls. Ed. Fumio Tatsuoka and Dov Leshchinsky, Balkema Publishers, Rotterdam, Netherlands, pp. 45-60.

Claybourn A.F. and Wu, J.T.H. (1993). " Geosynthetic-Reinforced Soil Wall Design," Geotextiles and Geomembranes, Vol. 12, pp. 707-724.

Collin C.G., Bright, D.G., and Berg, R.R. (1994). "Performance Summary of the Tanque Verde Project-Geogrid Reinforced Soil Retaining Walls", Proceedings, Earth Retaining Session, ASCE National Convention, Atlanta, GA

Derakhashandeh, M. and Barrett, R.K. (1986). "Evaluation of Fabric Reinforced Earth Wall", Federal Highway Administration Report No. CDOH-DTP-R-86-16, Lakewood, CO, September.

Fannin, R.J. and Hermann, S. (1990). "Performance Data for a Sloped Reinforced Soil Wall", Canadian Geotechnical Journal, Volume 27, Number 5, pp. 676-686.

Fannin, R.J. and Hermann, S. (1992). "Geosynthetic Strength - Ultimate and Serviceability Limit State Design", Proceedings of the ASCE Specialty Conference on Stability and Performance of Slopes & Embankments II, University of California, Berkeley, Ca., pp. 1411-1426.

FHWA (1989), "Tensar Geogrid-Reinforced Soil Wall", Federal Highway Administration Report No. FHWA-EP-90-001-005, Washington, D.C., January.

Fishman, K.L., Desai, C.S., and Sogge, R.L. (1993). "Field Behavior of Instrumented Geogrid Soil Reinforced Wall" Journal of Geotechnical Engineering, Vol 119, No. 3, August 1993, pp 1293-1307.

Ketchart K. and Wu, J.T.H. (1996). "Long-Term Performance Tests of Soil-Geosynthetic Composites", CDOT-CIT-96-1, Colorado Department of Transportation, Denver, CO.

McGown A., Andrawes K.Z., Yeo K.C., and DuBois D. (1984). "The Load-strain-time behaviour of Tensar Geogrids", Proceedings, Symposium on Polymer Grid Reinforcement in Civil Engineering, London, England, pp 11-17.

Simac, M.R., Christopher, B.R., and Bonczkiewicz, C. (1990). "Instrumented Field Performance of a 6 m Geogrid Soil Wall", Geotextiles, Geomembranes and Related Products . Ed. by Den Hoedt, Balkema Publishers, Rotterdam, Netherlands, pp. 53-59.

San, K. and Matsui, T (____). "1G Self Weight Failure Test and Simulation of a Geosynthetic Reinforced Retaining Wall" submitted to ASCE Geotechnical Journal for publication review.

Tatsuoka F., Tateyama M., Tamura Y., and Yamauchi, H. (____), "Lessons Learned from the Failure of a Series of Full-Scale Geosynthetic-Reinforced Soil Retaining Walls", Nonpublished.

Tatsuoka F., Murata O., and Tateyama M. (1992). "Permanent geosynthetic-reinforced soil retaining walls used for railway embankments in Japan", Geosynthetic-Reinforced Soil Retaining Walls. Ed. Jonathan T.H. Wu. A.A. Balkema Publishers, Brookfield, VT, pp. 101-130.

Vidal H. (1966). "La terre armee", *Annls L'intn. Techn. de Batiment et des Travaux Publics, Serie Materiaux* 30, Supplement no. 223-4, July-August

Wu J.T.H. and Tatsuka F (1992). "Laboratory Model Study on Geosynthetic Reinforced Soil Retaining Walls", Discussion, Journal of Geotechnical Engineering, American Society of Civil Engineers, Vol. 118, No. 3, pp. 496-498.

Wu, J.T.H. (1994a). "Long-Term Creep Behavior," Recent Case Histories of Permanent Geosynthetic-Reinforced Soil Retaining Walls, Ed. Fumio Tatsuoka and Dov Leshchinsky, Balkema Publishers, Brookfield, VT, pp. 343-344.

Wu, J.T.H. (1994b). "Design and Construction of Low Cost Retaining Walls: the Next Generation in Technology", CTI-UCD-1-94, Colorado Transportation Institute, Denver, CO.

Wu, J.T.H. and Helwany, S.M.B. (1996). "A Performance Test for Assessment of Long-Term Creep Behavior of Soil-Geosynthetic Composites," Geosynthetic international, Journal of International Geotextile Society, Vol. 3, No. 1, pp 107-124.