

**Report No. CDOT-DTD-R-2006-2
Final Report**

**FLOWFILL AND MSE BRIDGE APPROACHES:
PERFORMANCE, COST, AND RECOMMENDATIONS
FOR IMPROVEMENTS**

Naser Abu-Hejleh

Dennis Hanneman

David J. White

Trever Wang

Ilyess Ksouri



February 2006

**COLORADO DEPARTMENT OF TRANSPORTATION RESEARCH
BRANCH**

The contents of this report reflect the views of the author(s), who is (are) responsible for the facts and accuracy of the data presented herein. The contents do not necessarily reflect the official views of the Colorado Department of Transportation or the Federal Highway Administration. This report does not constitute a standard, specification, or regulation. Use of the information contained in the report is at the sole discretion of the designer.

Technical Report Documentation Page

1. Report No. CDOT-DTD-R-2006-2		2. Government Accession No.		3. Recipient's Catalog No.	
4. Title and Subtitle FLOWFILL AND MSE BRIDGE APPROACHES: PERFORMANCE, COST, AND RECOMMENDATIONS FOR IMPROVEMENTS			5. Report Date February 2006		
			6. Performing Organization Code		
7. Author(s) Naser Abu-Hejleh, Dennis Hanneman, David J. White, Trever Wang, and Ilyess Ksouri			8. Performing Organization Report No. CDOT-DTD-R-2006-2		
9. Performing Organization Name and Address Colorado Department of Transportation 4201 E. Arkansas Ave Denver, Colorado 80222			10. Work Unit No. (TRAIS)		
			11. Contract or Grant No.		
12. Sponsoring Agency Name and Address Colorado Department of Transportation - Research 4201 E. Arkansas Ave. Denver, CO 80222			13. Type of Report and Period Covered		
			14. Sponsoring Agency Code Study # 80.13		
15. Supplementary Notes Prepared in cooperation with the US Department of Transportation, Federal Highway Administration					
<p>16. Abstract: Construction of a typical Colorado DOT (CDOT) bridge approach structure includes placement of a high quality backfill material behind the abutment wall, and installation of a concrete approach slab supported by the bridge abutment wall at one end and the sleeper slab foundation at the roadway end. Since 1992, three new alternatives for the abutment backfill have been employed by CDOT: (1) relatively expensive flowfill; (2) lower cost mechanically stabilized earth (MSE) using granular, well-graded Class-1 Backfill, and (3) MSE using free draining Class B Filter soil. However, bridge bump problems at the sleeper slab are still occurring. In the Founders/Meadows bridge structure, both the bridge footings and approaches are supported by geosynthetic-reinforced soil (GRS) walls to minimize the uneven settlements between the bridge and its approaches (called "GRS Abutment"). Since this structure is unique, performance data from gauges embedded in the approaches and from smoothness tests were collected over five years. The objective of this study is to improve CDOT's current practice for bridge approaches (improve performance and reduce costs) based on the following information obtained in this study: 1) comments and suggestions collected from CDOT Staff and reported in the literature; 2) performance and cost-effectiveness of CDOT's MSE and flowfill bridge approaches and performance and design assessment of the Founders/Meadows GRS approaches; and 3) causes and sources of the bridge approach settlement problems observed in some of CDOT's MSE and flowfill bridge approaches.</p> <p>Implementation Statement: CDOT should use the lower cost MSE approaches with either Class B or Class 1 Backfill materials in its future projects. Flowfill should remain a viable alternative for certain field and construction scenarios that justify its higher costs. The use of an MSE or GRS abutment system should be considered as a viable alternative for all future bridges - it is the best system to alleviate the bridge bump problem. Additional recommendations are furnished to improve CDOT current practice and mitigate the bridge approach settlement problem in Colorado's new bridge approaches: 1) approach slab and roadway: select the appropriate construction elevation grades, and length of approach slab based on the projected post-construction settlements, warranty and smoothness requirements; 2) better support and drainage systems for the sleeper slab where the settlement problem occurs; 3) new and tightened construction requirements for the flowfill, Classes 1 and B Backfill materials; 4) suggestions for construction of tiered MSE wall around the bridge approaches; 5) suggestions for subsurface geotechnical investigation and settlement analysis of the fill and foundation soil layers; 6) design parameters for MSE approaches; and 7) recommendations for the bridge expansion devices and drainage measures. Finally, recommendations for the forensic investigation and repair of existing bridge approaches are presented.</p>					
17. Keywords bumps, approach slabs, abutments, backfill, cost-effectiveness, settlement, sleeper slabs, drainage, construction, repair, inspection, foundations, embankments, expansion devices, walls			18. Distribution Statement No restrictions. This document is available to the public through the National Technical Information Service, Springfield, VA 22161		
19. Security Classif. (of this report) Unclassified		20. Security Classif. (of this page) Unclassified		21. No. of Pages 236	22. Price

CONVERSION TABLE
 U. S. Customary System to SI to U. S. Customary System
 (multipliers are approximate)

Multiply (symbol)	by	To Get (symbol)	Multiply	by	To Get
LENGTH					
Inches (in)	25.4	millimeters (mm)	mm	0.039	in
Feet (ft)	0.305	meters (m)	m	3.28	ft
yards (yd)	10.914	meters (m)	m	1.09	yd
miles (mi)	1.61	kilometers (km)	m	0.621	mi
AREA					
square inches (in ²)	645.2	square millimeters (mm ²)	mm ²	0.0016	in ²
square feet (ft ²)	0.093	square meters (m ²)	m ²	10.764	ft ²
square yards (yd ²)	0.836	square meters (m ²)	m ²	1.195	yd ²
acres (ac)	0.405	hectares (ha)	ha	2.47	ac
square miles (mi ²)	2.59	square kilometers (km ²)	km ²	0.386	mi ²
VOLUME					
fluid ounces (fl oz)	29.57	milliliters (ml)	ml	0.034	fl oz
gallons (gal)	3.785	liters (l)	l	0.264	gal
cubic feet (ft ³)	0.028	cubic meters (m ³)	m ³	35.71	ft ³
cubic yards (yd ³)	0.765	cubic meters (m ³)	m ³	1.307	yd ³
MASS					
ounces (oz)	28.35	grams (g)	g	0.035	oz
pounds (lb)	0.454	kilograms (kg)	kg	2.202	lb
short tons (T)	0.907	megagrams (Mg)	Mg	1.103	T
<u>TEMPERATURE (EXACT)</u>					
Fahrenheit (°F)	$5(F-32)/9$ $(F-32)/1.8$	Celcius (° C)	° C	$1.8C+32$	° F
ILLUMINATION					
foot candles (fc)	10.76	lux (lx)	lx	0.0929	fc
foot-Lamberts (fl)	3.426	candela/m (cd/m)	cd/m	0.2919	fl
FORCE AND PRESSURE OR STRESS					
poundforce (lbf)	4.45	newtons (N)	N	.225	lbf
poundforce (psi)	6.89	kilopascals (kPa)	kPa	.0145	psi

FLOWFILL AND MSE BRIDGE APPROACHES: PERFORMANCE, COST, AND RECOMMENDATIONS FOR IMPROVEMENTS

by

Naser Abu-Hejleh, Ph.D., P.E., FHWA Resource Center
Dennis Hanneman, P.E., Kleinfelder, Inc.
David J. White, Ph.D., Iowa State University
Trever Wang, Ph.D., P.E., Colorado DOT (Bridge)
Ilyess Ksouri, Colorado DOT (Geotechnical Program)

Report No. CDOT-DTD-R-2006-2

Sponsored by the
Colorado Department of Transportation
In Cooperation with the
U.S. Department of Transportation
Federal Highway Administration

February 2006

Colorado Department of Transportation
Research Branch
4201 E. Arkansas Ave.
Denver, CO 80222
(303) 757-9506

ACKNOWLEDGEMENTS

The Colorado Department of Transportation and the Federal Highway Administration provided funding for this study. Thanks are extended to CDOT Maintenance Offices in Regions 1, 2, 4 and 6 who helped with collecting inspection records of the bridge approaches and to Steve White from CDOT Staff Bridge who provided valuable information on all bridges presented in this study. The CDOT Study Panel on this study and others provided in-depth technical review of this report and valuable comments from: Prof. George Hearn (University of Colorado at Boulder), Prof. Jorge G. Zornberg (University of Texas at Austin), Matt Greer (Colorado FHWA Division Office), Rich Griffin, Rene Valdez, Mike McMullen, Trever Wang, Cheng Su, Dennis Rhodes, Rene Valdez, Mike Gdovin, Aziz Khan, Skip Outcalt, Dean Sandoval, Tom Wrona, Corey Stewart, Mike Day, Pete Graham, Dick Osmun, and Alan Hotchkiss. Their knowledge and advice kindly offered in meetings, emails, telephone conversations, and field visits were essential to the successful completion of this report. Substantial help and support to this research were provided by Rich Griffin. Thank you all.

EXECUTIVE SUMMARY

The current typical Colorado DOT (CDOT) bridge approach system includes a foundation soil layer, an embankment fill soil layer, a high quality backfill material placed behind the abutment wall, a concrete approach slab supported by the bridge abutment wall at one end and the sleeper slab foundation at the roadway end (the sleeper slab is placed on the abutment backfill), a drainage system, and an expansion joint. Settlement at the sleeper slab leads to an abrupt change in elevation grade: a bump. Since 1992, three new alternatives for the abutment backfill have been used by CDOT: (1) relatively expensive flowfill (a low-strength concrete mix, 110 bridges, 1993-2001); (2) lower cost mechanically stabilized earth (MSE) (14 bridges, 1999-2003) with granular and well-graded Class-1 Backfill soil; and (3) MSE system with free draining Class B Filter soil (10 bridges, 2002 to 2005). Despite some performance improvements with these alternatives, the occurrence of significant approach settlement problems in flowfill and MSE approaches, resulting in high repair costs, is still being reported. In the Founders/Meadows bridge structure, both the bridge footings and approaches are supported by geosynthetic-reinforced soil (GRS) walls to minimize the uneven settlements between the bridge and its approaches (called “GRS Abutment”). Performance data from instrumentation embedded in the approaches and smoothness tests were collected periodically over five years.

The primary objective of this study is improve CDOT’s current practice for bridge approaches (improve performance and reduce costs) from results of the following tasks: 1) Document CDOT’s current practice for the geotechnical investigation, construction, and repair of bridge approaches and the comments and suggestions collected from CDOT Staff and reported in the literature to improve this practice; 2) Develop and apply a forensic investigation to determine the causes, sources, and time progression of the settlement problems experienced in CDOT’s MSE and flowfill bridge approaches; 3) Evaluate the performance of CDOT’s MSE and flowfill approaches and performance and design assessment of the Founders/Meadows bridge approaches; and 4) Estimate the total unit cost (construction and repair) needed to maintain acceptable performance of CDOT’s flowfill and MSE bridge approaches over their entire service life (for comparison between flowfill and MSE approaches).

Approach Settlement Problem in Colorado. There are four main causes of the observed bridge bump problems. First, the elevation grades of the as-built bridge and roadway approaches do not exactly match the design elevations leading to creation of a bump at the end of construction. The problem is worsened if the expansion joint is placed per the design elevation and not based on the as-built grades of the constructed bridge and approaching roadways. Second, failure of the installed drainage measures to keep surface and excess ground water from reaching the fill and foundation soil layers, which is a common factor in almost all the bridge approaches that experienced settlement problems. Water contributes to softening in soil zones between the granular soil layer and the underlying fine-grained soil layer. Third, settlement of the placed fill materials during or shortly after construction is completed can be due to lack of adequate compaction, construction during the cold season with frozen fill, and placement of fill materials dry of optimum leading to compression of the soil following subsequent wetting. And fourth, settlement of the compressible clay foundation soil layer that may not be detected or adequately addressed during design from the available subsurface investigation information. For example, water can soften the top of a clay foundation soil layer that derives apparent strength from desiccation.

Performance and Cost Results. Most of the flowfill and MSE bridge approaches constructed by CDOT since 1993 are performing well, with no settlement or cracking problems. Most of the settlement problems for the flowfill approaches are associated with the older bridge approaches constructed before 1994 when CDOT just started using flowfill. Out of 28 bridge approaches constructed with MSE Class-1 Backfill, 4 approaches failed due to poor construction operations. Performance/cost analyses indicate that the use of MSE Class 1 Backfill is more cost-effective than flowfill only if the rate of repair of MSE approaches will decline in the future. No problems are reported for the Class B Backfill approaches. The overall short- and long-term performance of the GRS approaches of the Founders/Meadows structure is excellent. Temperature has a significant effect on integral abutments, leading to continuous cyclic lateral movements of the MSE backfill with time (compression and expansion movement) and to cyclic lateral earth pressures (passive and active) against the abutment wall. Continuous expansion of the MSE backfill of approximately 1.5 to 2 mm every year was noticed. The presence of compressible polystyrene sheets behind abutment walls accommodated to a large extent (but not entirely) the

thermal expansion movement of the bridge superstructure and reduced the active lateral earth pressure to almost zero.

Implementation Statement: It is recommended that CDOT use the lower cost MSE approaches with either Class B or Class 1 Backfill materials in its future projects over the next few years and monitor their performance and document their repair costs. Flowfill should remain a viable alternative for certain field and construction scenarios that justify its higher costs. Warranty and smoothness requirements for bridge approaches are presented along with recommendations for construction of a tiered MSE wall system around the bridge approaches.

Two new supporting systems for the sleeper slab are suggested: the first system consists of placing most of the high quality MSE backfill under the sleeper slab rather than the approach slab (as currently employed by CDOT). The second supporting system consists of using driven piles to support the sleeper slab and using the much cheaper Class 2 Backfill material behind the abutments.

The length of approach slab (L) should be related to the projected long-term settlement (Δ) of the sleeper slab that would occur after the pavement structure is placed such that $\Delta/L < 0.005$. The study provides examples for computing the settlement of fill and foundation soil layers.

Replacement of the concrete approach and sleeper slabs with full depth asphalt approach slabs should be considered when the settlement is significant and occurring for a long period of time. Regular maintenance overlays will be needed.

The expansion device placed on top of the sleeper slab should be installed at an elevation that matches the as-constructed and surveyed grades of the bridge and approach roadway (minor adjustments from the design elevations), or even higher by up to one inch (for approach slab of 20 ft long) to compensate for the anticipated post-construction settlements (if pre-loading is not performed).

With regard to placement of backfill materials, it is suggested to add a construction requirement of vibration for the flowfill and compaction requirements as those established by CDOT for rocky embankments for Class B Filter soil. Further, it is recommended that CDOT's specifications for compaction of abutment and embankment fill soils be more rigorous, especially during the cold season, and for compaction of the top of a desiccated foundation soil layer that is susceptible to wetting induced softening. Compact granular fill soils wet of the optimum moisture and, after compaction is completed, consider dousing the soil with water to reduce the potential for future collapse.

For MSE approaches, the recommended design active and passive earth pressures should be considered with caution because they are based on limited data. It is recommended to use a softer (less dense) and thicker compressible (e.g., polystyrene) sheet in the upper zone of the abutment wall to minimize lateral earth pressures.

This study provides some criteria for selecting the appropriate location of test holes in the subsurface geotechnical investigation and suggests application of seasonal corrections to the measured SPT data if they are collected during the dry or cold seasons of the year. Three new measures are recommended to ensure that the joint placed above the sleeper slab does not allow water to seep into the soil under the sleeper slab. In addition it is recommended that drainage inlets at the end of a bridge deck to collect surface water before getting to the approach slab be adopted as standard design detail on all bridges. Current problems with drainage pipes, which seem not to work in many cases, should be corrected. It is recommended to place the expansion device over the abutment wall and not over the sleeper slab to prevent dragging of the approach slab which results in cracking. Finally, recommendations for forensic investigations and repair of bridge approaches are outlined.

TABLE OF CONTENTS

- 1.0 INTRODUCTION 1-1**
 - 1.1 Background 1-1
 - 1.2 CDOT’s Needs for Bridge Approaches 1-1
 - 1.3 Study Objectives and Overview of the Report 1-4
- 2.0 CDOT'S CURRENT PRACTICE FOR BRIDGE APPROACHES..... 2-1**
 - 2.1 Overview 2-1
 - 2.2 Abutment Walls, Foundations, and Wing Walls..... 2-1
 - 2.3 Concrete Approach Slab 2-2
 - 2.4 Abutment Backfill 2-3
 - 2.4.1 Conventional Granular Class 1 Structure Backfill..... 2-3
 - 2.4.2 Flowfill Structural Backfill 2-4
 - 2.4.3 Mechanically Stabilized Class-1 Backfill 2-5
 - 2.4.4 Mechanically Stabilized Class-B Filter Material 2-6
 - 2.5 GRS Abutment System 2-8
 - 2.6 Approach Embankment..... 2-8
 - 2.7 Bridge/Roadway Drainage System 2-10
 - 2.8 Bridge Deck Expansion..... 2-12
 - 2.9 Foundation Investigation at Bridge Approaches..... 2-13
 - 2.9.1 Subsurface Geotechnical Investigation 2-13
 - 2.9.2 Settlement Analysis..... 2-15
 - 2.9.3 Soil Improvement Techniques 2-17
 - 2.10 Repair of Colorado Bridge Approaches..... 2-17
 - 2.10.1 Overview 2-17
 - 2.10.2 Soil Stabilization Techniques..... 2-19
 - 2.11 Additional Recommendations from CDOT Staff to Improve Current Practice for Construction of Bridge Approaches..... 2-20
- 3.0 BRIDGE APPROACH SETTLEMENT PROBLEM: CAUSES AND FORENSIC INVESTIGATION 3-1**
 - 3.1 Overview 3-1
 - 3.2 Causes of the Soil Settlement at the Sleeper Slab..... 3-1

3.2.1	Influence of Moisture and Temperature Changes	3-4
3.3	The Forensic Investigation: Needed Information	3-6
3.3.1	Design, Materials, and Construction Records of the Bridge Approach Structure	3-7
3.3.2	Level, Location, and Time Progress of the Approach Settlement Problem.....	3-8
3.3.3	Subsurface Geotechnical Investigation	3-9
4.0	PERFORMANCE AND COST-EFFECTIVENESS ANALYSIS OF CDOT	
	 FLOWFILL AND MSE BRIDGE APPROACHES.....	4-1
4.1	Overview	4-1
4.2	Performance of Side by Side Bridge Flowfill and MSE Bridge Approaches	4-2
4.3	Procedure for Evaluation of Performance and Cost-Effectiveness of Flowfill and MSE Bridge Approaches.....	4-3
4.3.1	Performance from Records of CDOT's Bridge Management Section	4-4
4.3.2	Performance Based on Bridge Approach Settlement.....	4-5
4.3.3	Information on Applied and Required Repair Measures	4-6
4.3.4	Cost-Effectiveness Analysis of Flowfill and MSE Bridge Approaches	4-6
4.4	Region 6 Bridge Approaches	4-8
4.5	Region 4 Bridge Approaches	4-12
4.6	Region 1 Bridge Approaches	4-16
4.7	Region 2 Bridge Approaches	4-17
4.8	Performance and Cost-Effectiveness of Flowfill and MSE Bridge Approaches	4-18
5.0	INVESTIGATION OF BRIDGES WITH SEVERE BRIDGE APPROACH	
	 SETTLEMENT PROBLEMS.....	5-1
5.1	Objectives.....	5-1
5.2	Salt Creek (L-18-BD) (MSE Abutment Backfill)	5-2
5.2.1	Description of the Bridge Structure	5-2
5.2.2	Description of the Bridge Bump Problem.....	5-2
5.2.3	Review of the Construction Plans and Geotechnical Report	5-4
5.2.4	Results of the Subsurface Geotechnical Investigation.....	5-4
5.2.4.1	Backfill and Embankment Materials.....	5-4
5.2.4.2	Foundation Soils	5-6
5.2.5	Settlement Analysis and Results	5-7

5.2.6	Causes of the Approach Settlement Problem.....	5-10
5.2.7	Sources, Magnitude, and Timing of the Approach Settlement Problem.....	5-11
5.3	I-70/I-225 Interchange (Flowfill Abutment Backfill)	5-24
5.3.1	Overview of the Problem and Construction Plans	5-24
5.3.2	Results of Surface Inspection.....	5-25
5.3.3	Results of the Subsurface Geotechnical Investigation.....	5-27
5.3.4	Settlement Analysis and Results	5-28
5.3.5	Concluding Remarks and Recommendations	5-30
5.4	SH 287 Over Little Thompson River (C-16-DK) (Flowfill Abutment Backfill).....	5-39
5.4.1	Overview	5-39
5.4.2	Results of the Subsurface Geotechnical Investigation.....	5-40
5.4.2.1	Fill Materials	5-40
5.4.2.2	Foundation Soils	5-41
5.4.3	Settlement Analysis of the Sleeper Slab	5-42
5.4.4	Concluding Remarks.....	5-43
5.5	Structure E-19-Z on US 36 East of Bennett (MSE Abutment Backfill).....	5-49
5.5.1	Site Conditions and Observations of the Problem	5-49
5.5.2	Subsurface Geotechnical Investigation.....	5-50
5.5.3	Causes of the Approach Settlement Problem.....	5-50
5.5.4	Repair of Bridge Approaches.....	5-50
5.6	Structure E-17-PR at I-76 at 136 th Ave (Flowfill Abutment Backfill).....	5-52
5.6.1	Site Conditions.....	5-52
5.6.2	Subsurface Geotechnical Investigation.....	5-52
5.6.3	Causes of the Bridge Approach Settlement Problem.....	5-53
5.6.4	Recommendations.....	5-54
6.	PERFORMANCE OF THE FOUNDERS/MEADOWS MSE BRIDGE	
	APPROACHES OVER 5 YEARS	6-1
6.1	Introduction.....	6-1
6.2	Overview of the Study Investigation	6-1
6.3	Overall Performance of the Bridge Approaches	6-5
6.4	Moisture Changes in the MSE Abutment Backfill	6-9

6.5	Lateral Strains and Earth Pressures in the Abutment MSE Backfill.....	6-12
6.5.1	Measured Strains in the Reinforcements of the MSE Abutment Backfill	6-12
6.5.2	Horizontal Soil Pressure against the Abutment Back Wall	6-14
6.5.3	Design Implications of the Measured Results.....	6-17
7.	SUMMARY, STUDY FINDINGS AND RECOMMENDATIONS	7-1
7.1	Overview	7-1
7.2	Study Findings	7-4
7.2.1	CDOT's Current Practice for Bridge Approaches and Reported Suggestions For Improvement.....	7-5
7.2.2	Causes of the Bridge Approach Settlement Problem in Colorado.....	7-8
7.2.3	Performance of Different Systems Employed for Construction of Bridge Approaches	7-12
7.3	Recommendations	7-16
7.3.1	Systems for Construction of Bridge Approaches.....	7-16
7.3.2	General Recommendations	7-17
7.3.3	Better Support and Drainage Systems for the Sleeper Slab	7-17
7.3.4	Approach Slab.....	7-19
7.3.5	Flowfill Abutment Backfill	7-20
7.3.6	MSE with Class B Filter Material.....	7-21
7.3.7	MSE Backfill & Embankment	7-21
7.3.8	Influence of Temperature Changes on Integral Abutments	7-21
7.3.9	Foundation Investigation at Bridge Approaches.....	7-22
7.3.10	Bridge Expansion Device.....	7-23
7.3.11	Drainage Measures.....	7-23
7.3.12	Repair of Colorado Bridge Approaches.....	7-24
	REFERENCES.....	8-1
	APPENDIX A: CONSTRUCTION DETAILS OF CDOT'S BRIDGE APPROACHES. A-1	
	APPENDIX B: DETAILED PERFORMANCE DATA OF CDOT'S FLOWFILL AND MSE BRIDGE APPROACHES	B-1

**APPENDIX C: PHOTOS OF VARIOUS FLOWFILL AND MSE BRIDGE
APPROACHES IN COLORADO C-1**

LIST OF FIGURES

Figure 4.1	Measured Elevation Profiles for Structure C-15-U Where Side by Side Flowfill and MSE Approaches Were Constructed	4-3
Figure 4.2	Use of Caissons in the Repair of the Bridge Approach Settlement Problem at Structure E-17-PQ.....	4-11
Figure 5.1	A Section along the Front MSE Wall of the Salt Creek Bridge.....	5-15
Figure 5.2	A Section along the Upper and Lower MSE Walls of the Salt Creek Bridge.....	5-15
Figure 5.3	An Elevation Profile of the Bridge Approach along the Shoulder Line of the SW Corner of the Salt Creek Bridge Approaches.	5-16
Figure 5.4	A Settlement Profile of the Bridge Approach along the Shoulder Line of the SW Corner of the Salt Creek Bridge Approaches.	5-17
Figure 5.5	Elevation Profiles across the SW Corners of the Old (dashed line) and New (solid line) Bridge Approaches of the Salt Creek Bridge.	5-18
Figure 5.6	Boring Logs for the Salt Creek Bridge Approaches.....	5-20
Figure 5.7	Influence of Wetting on a Remolded Soil Sample of Loosely Compacted Class1 Backfill (Salt Creek Bridge Approaches)	5-21
Figure 5.8	Influence of Wetting on a Remolded Soil Sample of Well-Compacted Class1 Backfill (Salt Creek Bridge Approaches).	5-22
Figure 5.9	Predicted Settlements of the Sleeper Slab Due to Consolidation of the Foundation Clay Layer (Salt Creek Bridge Approaches).	5-23
Figure 5.10	Details of the Eastern Abutment of the WB I-70 to SB I-225 Bridge.....	5-33
Figure 5.11	Details of the CIP Retaining Wall Constructed along the Northern-Eastern Side of the I-70/I-225 Ramp.....	5-34
Figure 5.12	Elevation Profiles of the Eastern Approaches to the I-70/I-225 Structure.	5-35
Figure 5.13	Boring Log for the I70/I225 Bridge Structure.....	5-37
Figure 5.14	Predicted Sleeper Slab Consolidation Settlement of the I-70/I-225 Bridge Approaches	5-38
Figure 5.15	Boring Log for the SH 287 Structure	5-47
Figure 5.16	Predicted Settlement with Time at the Sleeper Slab of the SH 287 Bridge	5-48
Figure 5.17	Elevation Profile of the Approaches of Structure E-19-Z Before Repair.....	5-51

Figure 6.1	Typical Section through Front and Abutment GRS Walls of the Founders/Meadows Bridge Structure.....	6-4
Figure 6.2	Instrumentation Layout of Section 800 of the Founders/Meadows Bridge Approaches.	6-5
Figure 6.3	Locations of the Profiles Lines in the Founders/Meadows Bridge Structure.....	6-7
Figure 6.4	Measured Elevation Profiles Relative to the Bridge Abutment for Two Lines over the East Abutment along the Traffic Direction.....	6-8
Figure 6.5	Measured Elevation Profiles Relative to the Bridge Abutment for Two Lines over the West Abutment along the Traffic Direction.	6-9
Figure 6.6	Measured Changes in Soil Moisture Before and After Placement of the Drainage Protection System.	6-11
Figure 6.7	Measured Air Temperature below Girders of the Founders/Meadows Structure..	6-21
Figure 6.8	Measured Geogrid Tensile Strains at Various Times from Gages Placed in the MSE Abutment Backfill Behind the Abutment Wall as Shown in Figure 6.2.	6-22
Figure 6.9	Rough Estimate of the Expansion Lateral Movements of the MSE Abutment Backfill during Various Times.....	6-23
Figure 6.10	Measured Lateral Earth Pressure Against the Lower Portion of the Abutment Wall of the Founders/Meadows Bridge.	6-24
Figure 6.11	Measured Lateral Earth Pressure Against the Top Portion of the Abutment Wall of the Founders/Meadows Bridge (see Figure 6.2) during Various Times.....	6-25
Figure 7.1	The Driven Pile System Proposed for the 120 th Project Bridge Approaches	7-25
Figure 7.2	The MSE Wall System under the Sleeper Slab Proposed for the 120 th Project Bridge Approaches	7-26
Figure 7.3	The Most Economical Form of Drainage System Recommended for the Sleeper Slab	7-27

LIST OF TABLES

Table 2.1	CDOT Material and Construction Requirements for the Granular Class1 Backfill	2-4
Table 2.2	CDOT Material Requirements for Flowfill Backfill.....	2-4
Table 2.3	CDOT Specifications for Class B Filter Materials	2-7
Table 2.4	CDOT Description of Soils Based on SPT-N Values	2-14
Table 2.5	Typical CDOT Settlement Recommendations for Problematic Foundations Soils	2-16
Table 4.1	Ten Bridge Structures with Best Flowfill Approaches in Region 6.....	4-9
Table 4.2	Ten Bridge Structures with Worst Flowfill Approaches in Region 6	4-10
Table 4.3	Region 4 Problematic Flowfill Bridge Approaches	4-13
Table 4.4	Problematic Bridge Approaches in Region 2	4-17
Table 4.5	Performance of Flowfill and MSE Bridge Approaches	4-20
Table 4.6	Cost-Effectiveness Analysis of Flowfill and MSE Bridge Approaches.....	4-21
Table 5.1	Laboratory and Field Test Results for the Fill Material of the Salt Creek Bridge Approaches	5-6
Table 5.2	Laboratory and Field Test Results for the Foundation Soil of the Salt Creek Bridge Approaches	5-8
Table 5.3	Laboratory and Field Test Results for the Embankment Fill of the I-70/I-225 Interchange Approaches.....	5-29
Table 5.4	Laboratory and Field Test Results for the Embankment Material at the SH287 Bridge.....	5-41
Table 5.5	Laboratory and Field Test Results for the Foundation Soil of the SH287 Bridge	5-42
Table 6.1	Estimated Active, At Rest, and Passive Abutment Lateral Earth Pressures	6-15

1. INTRODUCTION

1. Background

A bump often develops at the end of a bridge near the interface between the abutment and the approaches. The main cause of uneven settlements in typical bridge foundation systems is the use of different foundation types. That is, while the approaching roadway structure is typically founded on compacted backfill soil, the bridge abutment is typically founded on much stronger soils or bedrock by deep foundations. Bridge bumps cause uncomfortable rides, create hazardous driving conditions, and require costly, frequent repairs with traffic delays. The problem affects 25% of the bridges in the United States, approximately 150,000 bridges, and the amount of maintenance required is estimated to be at least \$100 million every year (NCHRP Synthesis 234, 1997). The bump problem is a complex problem involving a number of components, including the natural foundation soil, the fill material, the foundation type used to support the abutment, the abutment type, the structure type, the bridge/roadway joints, the approach slab, roadway, and the construction methods. Numerous investigations have been undertaken during the past decades to identify the causes and minimize the differential settlements between the bridge abutments and their approaches. The most commonly reported causes of the bump in order of importance (NCHRP Synthesis 234, 1997) are:

1. Compression of the fill material
2. Settlement of the foundation soil
3. Poor construction practice
4. Poor drainage
5. Poor fill material
6. Loss of fill by erosion
7. Poor joints
8. Temperature cycles

1.2 CDOT's Needs for Bridge Approaches

Before 1992, the Colorado Department of Transportation's (CDOT's) measures to alleviate the bridge bump problem included the extension of wing walls along the roadway shoulders, and use of approach slabs and granular backfill (Class I Structural Backfill) behind the abutments. The approach slab is supported by the bridge abutment wall at one end and a sleeper slab foundation at the roadway end. The use of an approach slab allows a gradual distribution of any approach settlement and a smoother transition between the bridge and approaching roadway. CDOT began

using concrete approach slabs in the 1970s, and the majority of CDOT's bridge approaches built since 1990 have been constructed with the approach slab tied to the abutment wall.

Since 1992, CDOT has implemented several additional improvements to construction of bridge approaches in order to alleviate the bridge bump problem. Most of CDOT's new bridges are constructed with an integral abutment system where the abutment and the superstructure are rigidly connected to eliminate or reduce joints in the bridge superstructures. The integral end diaphragm type abutments are mostly supported by deep foundations. It is estimated that 10% of CDOT's bridge abutments are supported by shallow foundations, 50% by drilled shafts, and 40% by driven piles. Temperature cycles are more critical in integral abutments since the expansion and contraction of the bridge decks and girders lead to lateral displacement of the approach backfill. To overcome this problem, a very small gap or a compressible material (around 15 cm in thickness) is incorporated between the abutment fill and the bridge abutment. Four new systems for construction of bridge approaches have been implemented:

A. Flowfill Bridge Approaches. In November 1992, CDOT began using flowfill (a low-strength concrete mix) backfill behind the abutment wall to reduce the approach settlements. The self-leveling ability of flowfill allows it to flow, so no compaction is needed, and fill voids and hard-to-reach- zones (curved and cornered zones). Also, it experiences negligible settlements after curing. A total of 110 bridges were constructed with flowfill abutment backfill from 1993 to 2001 (none could be found in 2002 and 2003). Given the high cost of flowfill (\$76 per cubic yard in 2005) relative to conventional embankment material, the performance of existing installations should be studied to determine if this practice is worth continuing.

B. MSE Class 1 Backfill Bridge Approaches. The use of MSE (mechanically stabilized earth) Class-1 backfill behind abutments wall as a lower cost alternative to flowfill (\$37 /CY in 2005) has been a growing practice in Colorado. Standard details for MSE abutment Class-1 backfill were introduced in CDOT on May 21, 2000. A total of 14 bridges were constructed with MSE Class 1 Backfill between 1999 and 2003 (none before 1999). Most of the reinforcements in the MSE embankments are geofabric wrapped around the back face of the abutment, but geogrid (stiffer) reinforcements are considered in some situations to stiffen the backfill and further

reduce the approach settlements. The reinforced fill behind the abutment is used to build a vertical, self-contained wall capable of holding an approximately vertical shape and forming an air gap between the abutment and retained fill. By installing tensile reinforcements in the fill, it has been reported that a stiffer approach would be created. However, no field performance records are available for CDOT's MSE approaches with Class-1 Backfill.

C. MSE Class B (Porous) Backfill Bridge Approaches. In the last few years, Class B filter material has replaced the Class-1 Backfill in construction of 10 new MSE backfill bridges (cost \$57/CY in 2005). Class B filter material was selected because it is more free draining, is less susceptible to wetting induced softening/collapse, less erodible, has less fines for clogging drainage systems, and requires less compaction effort compared to Class-1 Backfill. Although these engineering properties are superior, performance information of the system was still needed.

Note that in Systems A, B, and C, the abutment walls were supported by deep foundations and this is not the case with System D presented next.

D. GRS Abutment System. In the Founders/Meadows bridge structure, constructed in 1999 near Denver, Colorado, geosynthetic-reinforced soil (GRS) walls were employed to support the shallow footings of a two-span bridge and the approaching roadway structures (see Chapter 6 for complete details, Abu-Hejleh et. al., 2000 and 2001 for references). The approaching roadway embankment and the bridge footing were integrated at the Founders/Meadows structure with an extended reinforced soil zone in order to minimize/alleviate the uneven settlements between the bridge abutment and approaching roadway (main cause of the bridge bump problem). This structure was considered experimental, and its approaches were instrumented during construction with moisture gages, strain gages, and pressure cells and profilometer tests were conducted to evaluate the smoothness of the approaches. Monitored performance data were periodically collected from beginning of construction through five years of service. There is a need to document and evaluate these data and summarize the lessons that are learned from this unique structure.

1.3 Study Objectives and Overview of the Report

But significant settlement at the sleeper slab in flowfill and MSE approaches still occurs, causing an abrupt change in elevation grade at the sleeper slab, resulting in high repair costs. Performance information on the recent systems and measures employed by CDOT to alleviate the bridge bump problem are needed. CDOT engineers need to know if their current practice is worth continuing or how it can be improved. In particular, the causes and sources of the approach settlement problem in Colorado bridges must be identified so that best practices can be implemented. This study was proposed to address all these needs.

The objective of this study is to provide recommendations to improve CDOT's current practice for construction of bridge approaches (improve performance and reduce costs). Several tasks were performed to meet this objective:

1. Summarize CDOT's current practice that has evolved since 1993 for the geotechnical investigation, construction, and repair of bridge approaches and the comments and suggestions collected from CDOT Staff and reported in the literature to improve this practice (Chapter 2 and Appendix A). The current typical CDOT bridge approach system includes a foundation soil layer where subsurface geotechnical investigation is performed followed by performing settlement analysis, an embankment fill soil layer placed on top of the foundation soil layer, a high quality backfill material (flowfill or MSE Backfill) placed behind the abutment wall and beneath the approach and sleeper slabs (described before), surface and internal drainage systems, and expansion joint device typically placed on top of the sleeper slab.
2. Provide detailed descriptions of *all* possible causes of the bridge approach settlement problem at the sleeper slab and the information needed in a forensic investigation to identify the causes and sources of this problem and determine if the settlement problem has more or less ended or if significant settlement potential remains in the future (Chapter 3). The causes include compression and creep movements of the fill and foundation soil materials (due to compressible soil layers, and applied static and dynamic loads), thermal movements of the bridge superstructure (of more concern with integral abutments), lateral movement of side walls (MSE

walls must laterally move to mobilize the tensile resistance of its reinforcements) problems in the geotechnical investigation, problems encountered during construction, and inadequate performance of the expansion joints and the drainage systems. A detailed description of the influence of moisture and temperature on soil settlements is presented. The information needed in a forensic investigation is: design, materials, and construction records of the bridge approach; structure, level, location, and time progression of the settlement problem; and information from a comprehensive subsurface geotechnical investigation that is described. Chapters 3, 4 and 5 present the procedure to collect and analyze this information for bridge approaches that experienced approach settlement problems.

3. Evaluate and compare the field performance and cost-effectiveness of bridge approaches constructed by CDOT with flowfill and MSE backfill materials (Chapter 4, Appendices B and C). Performance of side by side flowfill and MSE bridge approaches is presented for two bridges in Region 4. A procedure was developed and applied to: 1) evaluate the performance of MSE and flowfill bridge approaches, and 2) Estimate the total unit cost (construction and repair) needed to maintain acceptable performance of CDOT's flowfill and MSE bridge approaches over their entire service life (for comparison between flowfill and MSE approaches). The performance and cost (construction and repair costs) information were obtained from records collected by the CDOT Bridge Management Section, input from CDOT's Regional Maintenance Offices, and field visits, and from information published by the CDOT Engineering Estimates & Market Analysis Unit. Performance ratings for bridge approaches reflected the range of settlement experienced by the bridge approaches at the sleeper slab and the traffic speed (significant to moderate to slight bump problems).

4. Conduct a forensic investigation (including short- and long-term settlement analyses) on the MSE and flowfill bridge approaches that experienced significant settlement problems. The purpose is to determine the causes and sources of the current settlement problem and if this settlement has more or less ended or if significant settlement potential remains in the future (Chapter 5 and Appendix C). This information is needed to develop an effective plan for repair and mitigation of the settlement problem. The investigation was performed on five bridge structures, with three thoroughly investigated:

- a) Salt Creek Bridge along SH 50 (L-18-BD, MSE Backfill) in Region 2.
- b) SH 287 Over Little Thompson River (C-16-DK, flowfill) in Region 4.
- c) I-70/I-225 Interchange in Region 6 (flowfill).

And two more were previously investigated by CDOT Soil and Foundation Units:

- d) Structure E-19-Z on US 36 East of Bennett in Region 1 (MSE Backfill).
- e) Structure E-17-PR @ I-76 at 136thAve in Region 6 (flowfill).

5. Compile and analyze the data collected over five years on the performance and design assessment of the measures employed in the Founders/Meadows Bridge to alleviate the bridge bump problem (Chapter 6). Analysis of these performance data also provides insight into the behavior and validity of some of the design assumptions for MSE and Flowfill bridge approaches.

6. Based on the results of previous tasks summarize the study findings and the recommendations learned to improve CDOT's current practice for bridge approaches (Chapter 7).

2. CDOT'S CURRENT PRACTICE FOR BRIDGE APPROACHES

2.1 Overview

The evolution of CDOT's practice since 1993 for construction of bridge approaches is described in this chapter. The bridge approach system includes the following components: approach slab, drainage system and expansion joints, abutment backfill, embankment fill, and foundation soil. The main details of the bridge approach system are listed in Appendix A (Figures A.1 to A.6). Currently, CDOT has standards for details of MSE or flowfill abutment backfill materials used with concrete approach slabs (See Figures A.1 and A.2.) or without approach slabs (with asphalt approach slabs, see Bridge Worksheet B-206-M2 at <http://internal/StaffBridge>). Most (estimated 95%) of CDOT's bridge structures built in the last 13 years (since 1992) were constructed with a concrete approach slab (see Figures A.3, A.4, and A.5 for details) and a bridge expansion device (Figure A.6) installed at the sleeper slab foundation. The main sources for the information presented in this chapter are the CDOT Bridge Web Page that can be accessed online at <http://internal/StaffBridge> and CDOT Standard Specifications that can be accessed online at <http://www.dot.state.co.us/DesignSupport/Construction/1999text.htm>.

2.2. Abutment Walls, Foundations, and Wing Walls

Most of CDOT's new bridges are constructed with an integral abutment system where the abutment and the superstructure (girders and decks) are rigidly connected (through steel reinforcement and monolithic pour of concrete) to eliminate or reduce joints in the bridge superstructures. The integral, end diaphragm type abutments are mostly supported by foundations. It is estimated that 10% of CDOT's bridge abutments are supported by shallow foundations, 50% by drilled shafts, and 40% by driven piles. The abutments are usually supported on deep foundations because of stipulations such as bridge scour, and cost and benefit of carrying heavy loads with the latter being more dominant. Deep foundations are the most efficient means of transferring heavy loads from superstructures to substructures and bearing materials without significant distress from excessive settlement.

It has been a common practice at CDOT to use wingwalls for U-type Abutments. Normally, a wing wall will be cantilevered off the abutment. When the required wingwall length exceeds a practical length, a retaining wall is recommended. The same foundation system is recommended for supporting both the retaining and abutment walls to reduce risk of the retaining wall settlement relative to the abutment. The wing wall could be replaced with MSE walls, especially if MSE walls are employed to support the soil beneath the abutment wall.

2.3 Concrete Approach Slab

Subsection 7.3 of the CDOT Bridge Design Manual reads as follows. “Approach slabs are used to alleviate problems with settlement of the bridge approaches relative to the bridge deck. The main causes of this settlement are movement of the abutment, settlement and live load compaction of the backfill, moisture, and erosion. Approach slabs shall be used under the following conditions:

1. Overall structure length greater than 250 feet.
2. Adjacent roadway is concrete.
3. Where high fills may result in approach settlement.
4. When the District requests them.
5. All post-tensioned structures.”

CDOT started using concrete approach slabs in the 1970s. Most (estimated 95%) of CDOT’s bridge structures built in the last 13 years (since 1992) were constructed with concrete approach slabs. Construction of a new approach concrete slab is also considered in the rehabilitation of old bridge approaches. The remaining 5% of bridge approaches are constructed with asphalt approaches. Use of asphalt approaches is considered with smaller span bridges, bridges with low traffic, and when an adjacent roadway is asphalt.

CDOT provides three different details for the use of concrete approach slabs:

1. Concrete approach slab overlaid by 3” hot bituminous pavement (HBP) over waterproofing membrane that extends to the bridge deck and approaching roadway (Figure A.5). In this case, an expansion device is not employed. This detail, with

minimum length for approach slab of 14 ft, should not be used when the bridge length exceeds 250 ft, on bridges with integral abutments, nor when the approach roadway is concrete.

2. Concrete approach slab overlaid by 3” hot bituminous pavement over waterproofing membrane that extends to the bridge deck (Figure A.4.). In this case, an expansion device is employed. In this and the next case, the minimum length of approach slab is 20 ft (length revised on February 29, 1999).
3. Concrete approach slab with Bridge Expansion Device. This is used primarily with bare concrete bridge deck and adjacent concrete roadways (Figure A.3).

When the adjacent roadway is concrete, an expansion device is required between the end of the roadway and end of approach slab. In all cases, the approach slab is anchored to the abutment. The length of concrete approach slab ranges from 14 ft to 30 ft with a constant thickness of 12 inches. All of CDOT concrete approach slabs have a sleeper slab (discussed later) placed directly on the abutment backfill.

Dr. Trever Wang from CDOT Bridge Staff suggested that the length of approach slab be related to the depth of abutment of the bridge. Note that a longer approach slab requires a structural design with possibly larger concrete thickness and amount of reinforcements.

2.4 Abutment Backfill

2.4.1 Conventional Granular Class 1 Structure Backfill

Before 1992, CDOT measures to alleviate the bridge bump problem included the extension of wing walls along the roadway shoulder, and use of approach slab and granular backfill (Class I Structural Backfill) behind the abutments. The materials and construction requirements for Class-1 Backfill are presented in Table 2.1. Lift thickness is limited to 6 inches before compaction.

Table 2.1. CDOT Material and Construction Requirements for the Granular Class 1 Backfill.

	Requirements
1. Gradation	
50 mm, (% Passing)	100
Sieve # 4 ((% Passing)	30-100
Sieve # 50 (% Passing)	10-60
Sieve # 200 (% Passing)	5-20
2. Liquid Limit (%)	<35
3. Plasticity Index (%)	<6
4. Dry Unit Weight (kN/m ³)	95% of AASHTO T-180

2.4.2 Flowfill Structural Backfill

In November 1992, a CDOT Bridge Structural Worksheet was created for the use of flowfill (a low-strength concrete mix) backfill behind the abutment wall. The material requirements for the flowfill backfill are listed in Table 2.2. The current details for flowfill approaches are shown in Figure A.1. This revision was introduced to reduce shallow approach settlements (those resulting from the backfill), to prevent softening/erosion of the fill even if water infiltrated through the joints, and to improve constructibility/compactability of the fill behind the walls and around corners.

Table 2.2. CDOT Material Requirements for Flowfill Backfill.

Ingredient	Lbs/C.Y
Cement	50
Water	325 (or as needed)
Coarse Aggregate (AASHTO N. 57 or 67)	1700
Fine Aggregate (AASHTO M 6)	1845

The maximum lift thickness for flowfill is 3 feet and placement of additional layers is not permitted until the flowfill has lost sufficient moisture to be walked on without indenting more than 2 inches. Vibration to consolidate flowfill as in regular concrete is not required in CDOT construction specifications for flowfill. Some CDOT construction engineers argued that vibration

of the flowfill would further help alleviate the bridge bump problem (vibration-induced settlements of flow fill up to 2” were reported) and would stiffen the flowfill and allow it to set faster.

Before May, 31, 2000, the fill was placed on 1:1 slope (not the 2:1 slope as shown in Figure A.1). The construction of a 1:1 embankment slope with adequate compaction is difficult. The 2:1 slope also provides a smoother transition in stiffness from the abutment backfill to the adjacent embankment, further reducing the potential for approach settlement. This change in the slope, however, increased the quantities for flowfill especially in structures with deep abutments.

2.4.3 Mechanically Stabilized Class-1 Backfill

Details for MSE abutment Class-1 backfill instead of flowfill were introduced in CDOT on May 21, 2000 (Figure A.2). Most of the reinforcements in the MSE embankments are geofabric wrapped around at the abutment, but geogrid (stiffer) are considered in some situations to stiffen the backfill and reduce settlements. The reinforced fill behind the abutment is used to build a vertical, self-contained wall capable of holding an approximately vertical shape and forming an air gap between the abutment and retained fill (Figure A.2).

Thermal expansion and contraction of the bridge superstructure (decks and girders) cause lateral displacement of the approach backfill. This is a more critical factor with the use of integral abutment bridges, where abutment walls are strongly attached to the superstructure without joints. To overcome this problem, a system was developed where a very small gap (around 15 cm) is incorporated between the reinforced fill and the bridge abutment (Reid et al. 1998). It is hypothesized that the gap behind the abutment would allow for the thermally-induced movements of the integral abutment without affecting the backfill, thus reducing the applied passive stresses on the backfill soil to near zero. At the same time, this system would help to mobilize the shear strength of the retained approach fill and tensile resistance of the reinforcement, thus reducing the horizontal active soil pressure on the abutment wall. In later CDOT details, this gap was filled with 3” thick “compressible” low-density polystyrene or “collapsible” cardboard (Figure A.2) and it is also employed with flowfill approaches (Figure

A.1). This feature was incorporated in the Founders/Meadows structure and performance results of this feature will be presented in Chapter 6.

Since 1999, the use of MSE backfill behind abutment walls as a cost-effective alternative (unit cost is \$37 in 2005) to flowfill (\$76 in 2005) has been a growing practice in Colorado. In 1999 CDOT spent \$1,220,000 on flowfill. Due to the change in practice to MSE backfill, this dropped to \$300,000 in 2000. 2003 data suggest that 80% of new bridges are constructed with MSE backfill and 20% with flowfill backfill. Although the main advantage of MSE backfill is cost savings, the MSE technology may also provide several options for optimizing the abutment and wingwall design including:

- Replacing long cantilever wingwalls with MSE walls.
- Replacing the bottom portion of tall abutment with MSE wall,
- Reliably and economically removing earth pressures from the abutment/wingwalls.

As flowfill does, MSE backfill will also reduce shallow settlement effects, and with fabric wrap, provide superior retention of fines, but for less cost than flowfill. However, no field performance records are available for approaches constructed with MSE backfill. The MSE backfill will not, however, be as quick or as easy to construct as flowfill. Consequently flowfill will remain an option for projects where these advantages warrant the additional costs; e.g., a project where the excavation presents a deep awkward hole to fill in a minimum amount of time.

2.4.4. Mechanically Stabilized Class-B Filter Material

Since 2001, 5 bridges in Region 6 and 5 bridges in Region 4 were constructed with Class B filter material (see Table 2.3 for specifications) in lieu of Class 1 material for the abutment MSE backfill (see Table B.2 in Appendix B for the locations of these bridges). Most of the details of the bridge approaches were similar to those described for Class 1 backfill. In structures D-17-DN and D-17-DM in Region 4, the expansion devices were placed at the abutment wall, which according to Dick Osmun from CDOT Staff Bridge, is to prevent dragging of the approach slab due to the expansion and contraction of the bridge superstructure. This dragging may cause cracking. In structures D-17-CR and C-17-T in region 4, the drainage details were different from those of CDOT standards. The specifications required that the reinforced structure backfill resist

the loads carried by the sleeper slab with settlement less than 1% of the backfill height in order to minimize significant settlement or rotation of the approach slab. The specifications also required compacting the backfill to 95% of the maximum density as determined by AASHTO T-99. However, there is currently no quality control test procedure to ensure this compaction requirement is fulfilled. This created a problem for the field project engineers. To ensure appropriate compaction level for this backfill material, using compaction specifications similar to those established for the rocky embankments (Section 2.6) could be adopted.

It seems that Class B Filter Material has been considered by some CDOT engineers for the following reasons:

1. The water will not soften or collapse the backfill, all possible with Class 1 backfill as demonstrated later in this report.
2. Preserve the backfill behind the abutments and wingwalls without loss of materials due to erosion, water intrusion, or surface and subsurface drainage.
3. It will not cause clogging of the internal drainage systems.
4. *It is more free draining than Class 1 Backfill. This will prevent the possible buildup of a pressure head in the backfill and the soil beneath.*
5. Minimal compaction efforts are needed.

Table 2.3. CDOT Specifications for Class B Filter Materials.

703.09 Filter Material. Filter material shall consist of free draining sand, gravel, slag, or crushed stone. The grading requirements are set forth in Table 703-7.

**Table 703-7
GRADATION SPECIFICATIONS FOR FILTER MATERIAL**

Sieve Size	Mass Percent Passing Square Mesh Sieves		
	Class A	Class B	Class C
75 mm (3")	100		
37.5 mm (1½")		100	
19.0 mm (¾")	20-90		100
4.75 mm (No. 4)	0-20	20-60	60-100
1.18 µm (No. 16)		10-30	
300 µm (No. 50)		0-10	10-30
150 µm (No. 100)			0-10
75 µm (No. 200)	0-3	0-3	0-3

2.5 GRS Abutment System

In the Founders/Meadows bridge structure, constructed in 1989 near Denver, Colorado, geosynthetic-reinforced soil (GRS) walls were employed to support the shallow footings of a two-span bridge and the approaching roadway structures. This system is referred to as GRS Abutment (see Chapter 6 for complete details, Abu-Hejleh et. al., 2000 and 2001 for references).

The main cause of uneven settlements in typical bridge foundation systems is the use of foundation type for the bridge abutment different than for the approach roadway. That is, while the approaching roadway structure is typically founded on compacted backfill soil, the bridge abutment is typically founded by deep foundations on stronger soil and bedrock. To overcome this problem in the Founders/Meadows structure, the approaching roadway embankment and the bridge footing were integrated with an extended reinforced soil zone in order to minimize/alleviate the uneven settlements between the bridge abutment and approaching roadway. Several measures were also implemented in this project to prevent surface water and groundwater from reaching the reinforced soil mass and the bedrock at the base of the fill. A compressible 75 mm thick low-density expanded polystyrene sheet was placed between the reinforced backfill and the abutment walls to accommodate the thermal cyclic movements of the integral abutment walls. This structure was considered experimental, and its approaches were instrumented during construction with moisture gages, strain gages, and pressure cells and profilometer tests were conducted to evaluate the smoothness of the approaches. Monitored performance data were collected from beginning of construction through five years of service. As presented later in Chapter 6, the collected performance data provide insight into the behavior and validity of some of the design assumptions of CDOT MSE and Flowfill bridge approaches.

2.6 Approach Embankment

Compacted roadway embankments are needed between the abutment backfill and existing ground (i.e., not needed behind the abutment backfill for bridges in cut as seen in Figures A.1 and A.2).

Section 203 of CDOT Standard Specifications provides details for the material and construction requirements of embankment materials. Embankment material shall consist of approved material acquired from excavations, hauled and placed in embankment. Section 203 states that frozen materials shall not be used in construction of embankment. Embankments shall not be constructed entirely of large rock but shall be constructed in a manner that provides a dense, well-graded, earthen mass. Rocks having any dimensions greater than 4" shall not be placed in the top two feet of embankment. Approval for the embankment material will be contingent on the material having a resistance value specified in the project when tested by Hveem Stabilometer, or equivalent resilient modulus, of at least that specified in the contract, and a maximum dry density of not less than 90 pounds per cubic foot. The material must be stable when tested in accordance with Colorado Procedure L-3102. Embankment materials include soil embankment, rock embankment, and rock fill.

Soil Embankment (materials smaller than 4.75 mm) shall be constructed with moisture density control. Maximum dry density and optimum moisture content of all soil types is determined in accordance with AASHTO T 99 or T 180. For A-1, A-3, A-2-4 and A-2-5 granular soils, placed loosely in horizontal layers not exceeding 8", the minimum relative compaction is 100% following T-99 or 95% following T-180. All other finer soils should be compacted to a minimum relative compaction of 95% of the maximum dry density as determined in accordance with T 99 or 90% with T 180. The amount of water to be used in compacting A-2-6, A-2-7, A-4, A-6, and A-7 (fine soils) shall not deviate from optimum on the dry side by more than two percentage points. A-4 soils that are unstable at the above moisture content shall be compacted at a lower moisture to the specified density. The amount of water used in compacting all other soils shall be as required to obtain the required percent relative compaction. Some CDOT Project Special Provisions (not standards for all projects) read as "Embankment material containing primarily soils shall be moisture conditioned to +2 percent of optimum moisture content based on AASHTO T 180 compaction criteria. "

Rock Embankment (materials with 50% or more by mass, at field moisture content, larger than 4.75 mm and smaller than 150 mm). Rock embankment shall be constructed without moisture density control. Each layer of rock embankment shall not be covered by another layer until the

engineer is satisfied that adequate compaction has been obtained. Rock embankments are largely used by CDOT in the mountain areas where more specific requirements for the construction of rock embankments are developed and incorporated into project special provisions. Some of these specifications are as follows. Rock embankment shall be sprayed with 20 gallons of water per cubic yard of rock fill prior to compaction. Heavy vibratory compactors with weights of at least 15 tons and vibratory frequency of 30 hertz shall be used for compaction of all embankments. The presence of water will ease compaction of the fill especially with the use of heavy vibrator rollers. It becomes easier for the fill soil materials to move to a denser configuration: the finer soil particles fill the voids between the large soil particles. The Contractor shall incorporate test fills in the work including rock embankment to establish and demonstrate methods and procedures to moisten and compact fill materials to specified conditions. Based on the results of test fills, the minimum number of passes of each type of compactor shall be chosen which consistently produces the minimum specified relative compaction. Each subsequent layer of fill shall be compacted with the minimum number of passes developed above. Additional compactor coverages shall be made as needed to obtain the minimum specified relative compaction.

2.7 Bridge/Roadway Drainage Systems

One of the important means of maintaining the strength and avoiding water-induced backfill distress or even failure of embankment and backfill is to prevent surface and ground water from entering the fill and embankment. Cracks in concrete pavement are often noticed close to the expansion joint. Water leaking through faulty joints and cracked concrete seems to soften the fill and cause internal erosion as the fines are washed out. This can create voids beneath the approach slab (the influence of water is presented in great detail in Chapter 4). To provide an adequate internal drainage system behind the abutment and wingwalls, a layer of Class-B filter-material is constructed before placement of the backfill. A six-inch diameter perforated pipe is installed at the bottom to collect excess water. This water, in turn, is then carried by a non-perforated pipe which daylights through the wing walls. Other drainage systems were incorporated in Structure E-17-PQ (see Figure 4.3) and in the Founders/Meadow structures (Chapter 6). It is a standard in CDOT guidelines to place an impervious membrane with collector pipes at the top of the MSE wall, but it is not standard for MSE backfills for bridge approaches.

It is recommended to place similar membrane details in CDOT bridge approaches that are constructed with MSE Class 1 backfill.

On November 1, 1999, changes were made to Subsection 16.1 of CDOT Bridge Design Manual titled "Bridge Drainage." A complete Bridge drainage system consists of:

1. The Bridge Deck Drainage System (BDS) includes all drains located on the bridge decks and the means used to convey the water collected by them. Based on the hydraulic recommendations and structural design of the bridge, appropriate locations for deck drains are selected. Use of curb cuts for deck drains is discouraged. Pipes are attached to the deck drain. Revisions of Section 513 provide a description of the material and construction requirements for pipes and downspout pipes for bridge drains.
2. The Bridge End Drainage System (BEDS) intercepts drainage immediately upslope or down slope of the bridge and daylights between 6" and 1' above the toe of the fill or the rip-rap at that location.

On February 29, 1999, new revisions were made for placement of bridge rails on approach slabs instead of wingwalls (rail and approach slab are rigidly connected as in the details shown in Figures A.3 to A.5). This important revision eliminated the joint between the rail and approach slab, thus reducing the infiltration of surface water through joints to the fill. Also, drainage inlets are now placed in the approach slab, or end of deck, to collect the bridge surface water before it reaches the expansion joints. This helped in preventing the water from infiltrating into the backfill beneath the approach slab.

Mr. Rene Valdez recommended making it standard, not a designer choice; to place a drainage inlet at the end of a bridge deck before getting to the approach slab. It seems that the calculated bridge camber usually does not work out right, and water is retained at the abutments and many times the pier locations as well. Installing drains on the bridge near the abutment would improve the standing water problem at the bridge ends that contribute to the approach settlement problem.

2.8 Bridge Deck Expansion

Bridge decks experience translation movements due to thermal changes. As the temperature rises, the deck expands in length and as the temperature decreases, the deck contracts. Creep, shrinkage, and prestressing of concrete also cause permanent span length changes over time (growth of span). All these actions led in the past to damage to the abutment walls, especially when concrete roadway pavement is placed next to the bridge. To address this issue, bridge deck expansion joints are placed on sleeper slabs and/or the abutment wall. Bridge deck expansion joints are not recommended when the superstructure and substructure can be economically designed to accommodate the resulting thermal, creep, and shrinkage deformations and forces. Expectations from the bridge expansion device are to: 1) allow for expansion and contraction of bridge structures, 2) seal the sleeper slab to prevent water, salt, and other roadway contaminants associated with deck and roadway runoff from entering the fill, and 3) provide a smooth, quiet roadway surface.

The bridge expansion joint is often moved from the abutment wall to the sleeper slab. If the expansion joint is not properly maintained, the problem (water leakage) is then moved to the roadway end of the bridge approach. Contraction is restrained by ground friction on the lower surface of the approach slab, which could lead to open cracks.

According to Section 15.1 of CDOT Bridge Design Manual, the armored elastic strip seal joints (Figure A.6) had the best long-term performance and are recommended for use on all new construction, at the end of approach slabs, and at any joint with anticipated movement normal to the joint of 4" or less. Strip seal joints consist of a premolded gland of neoprene rigidly attached to a metal facing on both sides of the joint. On May 18, of 2001, the armor-angles were removed and replaced with two armor legs to protect the surrounding concrete. Modular expansion devices that consist of multiple strip seals are recommended when the range of movements exceeds 4 inches. The new type bridge expansion device has two armored legs and is expected to have better performance than the old type. For replacement of failed joints where the movement at the joint is 2 inches or less, plug expansion devices are recommended.

The expansion device was extended in 1994 to the curb and bridge rail (Figure A.3 and A.4). The lack of expansion devices in these locations led in the past to drop, shift, and break up of the bridge rails due to the expansion movement of the bridge and approaches.

Lessons learned from NCHRP Synthesis 319 Report on bridge joints published in 2003.

- Several states include performance standards for new joint seals, with new requirements to ensure the joint doesn't leak.
- Lessons to maximize the joint seal service life are provided.
- Most bridge owners favored the premolded strip seal joints for short-to moderate spans. This type of joint is best used when the movement rating is beyond the capacity of compression seal and for larger skews.
- For longer spans, the preferred joints were the finger joint and the modular system joint. For those who give cost a high priority, the finger joint (open joint) was preferred, with a trough to collect material passing through the opening. For those who demanded watertightness, the modular system was the choice.

2.9 Foundation Investigation at Bridge Approaches

2.9.1. Subsurface Geotechnical Investigation

Approach embankments require more detailed geotechnical exploration than other embankment areas. Typically, test borings (drill holes) for the approach embankment are located at the proposed abutment locations to serve a dual function. The depth of the boring will usually be determined by criteria established for the structure design (see AASHTO Manual on subsurface investigation, 1988; and Abu-Hejleh et al., 2003). In all cases, a boring will extend a distance into competent soil or rock of suitable bearing capacity or to a depth where added stresses due to estimated footing load is less than 10% of the existing effective soil overburden stress, whichever is the greater (AASHTO, 2002). Additional shallow explorations are commonly taken to a depth of twice the embankment height, or based on experience with local geologic conditions. The objective of these borings is to obtain information and samples necessary to define soil and rock foundation subsurface conditions for the approaches.

Test holes are advanced using a 7 1/2-inch diameter hollow stem auger (HSA) or 4-inch diameter continuous flight power auger. The most common field sampling and penetration testing procedures used in Colorado are the standard penetration test (SPT) method in accordance with ASTM D1586 and the California Sampler (see Abu-Hejleh et. al., 2003 for complete details of these techniques). CDOT drill rigs have automatic hammers via a chain mechanism that ensures the appropriate drop height for each blow. With these two techniques, driving resistances (N-value or # of blows to drive 12”) of the soil at different depths of the same hole are obtained and samples are recovered for visual inspection in the field and subsequent laboratory testing. Laboratory testing includes gradation (e.g., % of gravel, % of sand, and % of fines: silt and clay) and Atterberg Limits (LL for liquid limit and PI for plasticity index) and insitu water content. These results are used to classify the soil by both AASHTO classification (e.g., A-7, A-6) and the Unified Classification System (e.g., CH and CL). From the soil samples recovered with the California sampler, information on the in situ soil unit weight (γ) can also be measured. For faster testing and when there is no need to recover soil samples, the Continuous Penetration Test according to Colorado Procedure CP-L 3201 is performed to get a rough estimate of the penetration resistance of soil layers. Measured driving resistance values (N-values) are employed to describe the relative density of granular soils and consistency of cohesive soils per Table 2.4. PVC piezometers are installed in borings to monitor groundwater conditions.

The generated logs summarize the description of the soil layers encountered, locations and types of recovered soil samples, results of the driving resistance values (N-values) at various depths, and locations of the Groundwater Table (GWT). Occasionally, as needs arise, consolidation tests (AASHTO T 216) may be performed on undisturbed cohesive soil samples obtained with either the Shelby tubes (pushed in relatively softer soils) or the California Sampler.

Table 2.4. Colorado’s Description of Soils Based on SPT-N Values.

Cohesionless Soils		Cohesive Soils	
Penetration Resistance (Blows/ft)	Description	Penetration Resistance (Blows/ft)	Description
0-4	Very loose	0-2	Very Soft
4-10	Loose	2-4	Soft
10-30	Medium Dense	4-8	Medium Stiff
30-50	Dense	8-16	Stiff
Above 50	Very Dense	16-30	Very Stiff

2.9.2 Settlement Analysis

The approach settlement can be attributed to two major sources: settlement of the new compacted fill (abutment fill and embankment fill) and settlement of the foundation soils, thus the settlement must be assessed *for both* sources (see more comprehensive discussion in Chapter 4).

No routine settlement analysis is performed for fill materials, expected to be stiff or dense once compacted per CDOT compaction requirements (as presented before). Settlement for properly compacted backfill material is roughly estimated to be 1% of the total fill height (some consulting firms assume 0.5%). When the compacted fill is granular soil, the settlements take place almost instantly and are easier to evaluate and resolve (correctable). It is often reported that the wall's granular backfill will consolidate during and after construction and this settlement is related to the depth of the fill, the degree of compaction, the moisture content, and type of fill. *This assumption is evaluated later in this study.* When compacted clay fill is employed for construction of embankments around the abutment fill, the settlement becomes time dependent and the investigation requires information on the consolidation characteristics of the placed fill. *No guidelines are available to estimate the magnitude and timing of settlement of clayey embankment fill materials placed around the abutment fill material.*

The foundation soils for bridge approaches must be considered excellent (before or after improvement) with low compressibility: produces little (or tolerable) settlement under the weight of the new fill and traffic loads. When the foundation soil is granular and/or properly compacted, the settlement is usually not problematic. When granular or clayey foundation soils are judged problematic, their properties must be improved through appropriate soil improvement techniques, until their compressibility is judged acceptable.

Various factors control the level of foundation settlement analysis performed by CDOT (this paragraph is based on personal communications with Dr. Aziz Khan from CDOT Geotechnical Office), including height of the new fill and thicknesses and types of the foundation soil layers. Rigorous settlement analysis for foundation soil may not be needed if the foundation soil is very

stiff clay, and/or if the height of the embankment fill is small with stiff foundation clay. If the foundation soil is described as soft clay, then detailed settlement analysis is performed using the results of consolidation tests performed on representative soil samples. For many cases, the coefficients of consolidation (for clayey soils) and the stress-strain modulus (for clayey and granular soils) are roughly estimated through correlations with description of soils from design charts available in geotechnical engineering literature (e.g., Foundation Engineering by Bowles) or from design manuals (e.g., NAVFAC). Typical examples of CDOT settlement recommendations are:

- “Negligible” amount of settlements.
- It is anticipated that the bearing pressures imposed by the new embankment fill on the clayey soils will result in time-dependent settlements of approximately 4 inches. It is recommended that the new embankments be constructed as early as possible to minimize the potential impact of differential settlement. The minimum period of preloading should be three months.
- The bearing pressures imposed by the retaining walls on the fully saturated soils will result in time-dependent settlements as shown in Table 2.5. If these settlements are deemed unacceptable, ground improvement methods can be implemented to minimize the impact of settlements. It is our understanding that preloading and/or surcharge loads are being considered to improve the soft foundation materials.

Table 2.5. Typical CDOT Settlement Recommendations for Problematic Foundation Soils.

Thickness of Silty Clay Layer (ft)	Estimated Settlement (inches)			Settlement Time (months)	
	<i>24-Foot Embankment</i>	<i>18-Foot Embankment</i>	<i>12-Foot Embankment</i>	50% of Estimated Settlement	90% of Estimated Settlement
12	6-8	4-6	2-4	12	48
8	4-6	2-4	1-2	6	24
4	2-3	1-2	1	3	12

Mike McMullen (An ex Senior CDOT Bridge Engineer) wrote on 9/8/03 the following: “I think a useful internal process change would be to always get quantitative (rather than qualitative) short term and long term settlement estimates for the soil under the embankment at the abutment as a part of the foundation report for structures, keeping in mind that the estimates are probably

off by a factor of two one way or the other. Current geotechnical recommendations can usually be separated into two recommendations, "no problem" and "big problem", as opposed to the typical reality of 1/2 to 4" inches of settlement of the embankment after pavement placement. Keep in mind that we need data on the existing structures with a true "no problem" to characterize what works as well as locating the problems.”

2.9.3 Soil Improvement Techniques

When soils with undesirable properties occur in the foundation, some strategic measures will have to be taken to remove or improve the bad soils. Many improvement techniques are available to improve the soils depending on the soil types. Loose granular soil improvement measures include surcharge, dynamic compaction, compaction piles, grouting, gravel columns, etc. The improvement techniques for non-granular soil include preloading, surcharge, and installation of wick drains, dynamic compaction, excavation and re-compaction, stone columns, lime treatment and grouting. For the specifics of each technology, readers are advised to refer to the FHWA manual on ground improvements.

Depending on site conditions, CDOT Geotechnical office can recommend excavating and replacing clayey material, preloading, and surcharging loads. In addition, the CDOT designer can choose various ground improvement methods (wick drain, stone columns, compaction grouting).

2.10 Repair of Colorado Bridge Approaches

2.10.1 Overview

The conditions of CDOT bridge approaches are monitored continuously by CDOT maintenance and bridge inspection personnel as will be discussed in the next chapter.

With no signs of deterioration to the approach slab other than superficial surface cracks or minor break-up, crack sealing and patching with asphalt are performed by CDOT Maintenance forces. An approach settlement problem is noticed by CDOT Maintenance from snowplow operations, clear drop of sleeper slab more than 1”, rideability, or from visual inspection by CDOT

maintenance or bridge inspectors. When a low approach or a bridge bump problem is first noticed, a leveling asphalt layer, either hot or cold depending on outdoor temperature, may be applied on the approach slab and adjacent roadway and bridge deck to smoothen the transition area. If the application of asphalt course is not feasible (approach roadways and bridge decks are bare concrete), one of the stabilization techniques presented below may be considered to raise the sleeper slab. If a concrete slab is in bad shape, CDOT maintenance may replace the damaged slab sections with the use of high-early strength roadway concrete.

If the approach settlement problem is excessive or the approach slab continues to drop with time (after multiple applications of asphalt overlay), this may warrant a geotechnical subsurface investigation to determine the causes of the continued approach settlement and pavement distress and to provide recommendations for one of two remedial measures:

- Application of one of the stabilization techniques presented in the next section to stabilize the fill. In most cases, the stabilization technique is also employed to smoothen the approaches by raising the sleeper slab and approaches, especially if application of an asphalt layer is not feasible, as when adjacent roadways and bridge are concrete.
- Removal and replacement of the approach slab and abutment backfill. This alternative is very costly and is considered only when it is believed that the problem is in the upper soil layers close to the ground surface. Any damaged expansion joint or rail may be replaced in this case.

A comprehensive repair project will also offer a chance to improve the surface drainage measures and any other details and bring them up to meet CDOT current requirements. For example, in the repair of Bridge structure E-17-PQ, 4 new bridge deck drains were installed near the abutments, at the four corners of the bridge deck. Also, for old bridge rails that could not be replaced to meet current requirements, gaps are now cut in the bridge rails at the expansion joint location and cover plates are added over the gaps. This is performed to prevent the shift and/or break up of the Type 4 rail walls due to the expansion of the bridge and approaches.

2.10.2 Soil Stabilization Techniques

- ❑ **Pressure grouting under slab.** CDOT Region 6 hires a local company to perform this technique for stabilizing the soil and filling the voids beneath the approach slab through injection of flowable grout (not to raise the slab). The presence of voids beneath the approach slab leads to instability, cracking, sinking and ponding problems. The grout mix has 94 pounds of cement, 70 pound of fly ash, 15 gallons of water, and it is optional to include 10 pounds of lime. In this procedure, 1 7/8" holes are drilled through the concrete or asphalt approaches using a rectangular spacing. The depth is determined by the ease of driving the stinger or outlet tube, which is pounded into the hole. A fence post pounder is used to hammer the stinger and extension pieces into the soil. As the stinger is pounded down, one can tell if the soil is loose or soft and if there are voids. In Region 6, this technique has helped to arrest the settling in some problematic bridge approaches.

- ❑ **Slab jacking or mudjacking technique.** This has an additional objective to raise or lift the slab and in this case the grout mix is thicker than in the previous case. Precautionary measures should be taken if this technique was applied near to side retaining walls and abutment walls.

- ❑ **The Urettek Method** (see <http://www.stableconcrete.com/uretek.html> for more details). It involves the precise liquid injection of high-density polyurethane plastic through small (5/8") holes drilled in the sagging concrete slab. Once in place, the material expands to lift and stabilize the slab, while filling voids in the underlying soil and under sealing the existing concrete. According to the owner of this patent technology, this technology is simple, rapid, and leads to permanent solutions (resists erosion and compression over time).

- ❑ **Compaction or High Pressure Grouting.** For stabilization of both shallow- and deep-seated soft layers, the high pressure grouting (or compaction grouting) can be employed to densify the embankment soil and to lift and level the approach slab and adjacent roadways (FHWA, 1998). Section 211 of CDOT Standard Specifications describes the materials and construction requirements for this procedure. Compaction grouting features the use of low

slump, low mobility grout of high internal friction. In weak or loose soils, the grout typically forms a coherent “bulb” at the tip of the injection pipe thus compacting and/or densifying the surrounding soil. This technique is effective in all relatively free draining soils including gravel, sands, and coarse silts. FHWA (1988) reported the use of this technique in Glenwood Canyon to decrease the settlement potential of retaining walls and strengthen the soil against the effect of water wetting, believed the cause for the settlements problem there.

Any reported comments on the performance of the following techniques are presented in Chapter 4.

2.11 Additional Recommendations from CDOT Staff to Improve Current Practice for Construction of Bridge Approaches

This section summarizes reported recommendations for improvement of CDOT current practice for bridge approaches that were not presented in the previous sections. These were obtained from comments provided by various CDOT staff.

Mr. Dennis Rhodes from CDOT Region 6 wrote: “The best approaches are those constructed long ago 1950-1970 because construction timing was longer, allowing for more settlement and densification of the foundation and fill soil, and better deck surface drainage systems were installed to keep the water off the approach slab.” He recommended tighter backfill compaction specifications close to the walls, and better surface and internal drainage measures. Dennis also recommended a warranty by the contractor for bridge approaches in the first year of service.

Mr. Rene Valdez from Region 6 recommended requiring smoothness requirements around the bridge expansion joints. No such requirements are available within 25 ft of each joint.

Mr. Tom Wrona, Region 2 South Program Engineer provided valuable comments for improvements of CDOT current practice. He wrote:

“The South Program Area of Region 2 has experienced their share of bridge approach settlement problems. MSE and flowfill backfill have not been a cure-all. It is frustrating to Region Engineering and Maintenance to have to deal with these settlement problems immediately after accepting a new project and sometimes during construction before the project is accepted.

Mudjacking and urethane foam won't work to correct the problem in many situations such as MSE Wall unconfined bridge approaches. We should probably consider using CIP reinforced concrete wingwalls in the approach areas to provide the confinement that you could pressure grout against to raise the slab. It is very costly and inconvenient to the traveling public to completely remove the approach slab, reconstruct the embankment at the approach, then replace the slab. Maybe we should just eliminate the approach slabs altogether then the repairs to the approaches could be made more cost effectively when the settlement occurs.

I agree with your idea that we should include bridge drains at all four corners of all bridges, assuming a crown section, unless it is a sag bridge. It seems that the calculated bridge camber never works out right and we always hold water at the abutments and many times the pier locations as well. The drains located on the bridge near the abutment would improve the standing water problem at the bridge ends that contribute to the approach settlement problem once started. Perhaps another foundation type for the sleeper slab should be used since it appears that the settlement occurs at this location or would this just move the problem further from the bridge?”

Mr. Dean Sandoval from Region 2 indicated that a bump could be created at end of construction if the expansion joint is placed per the plan grades not based on grades of the constructed bridge and approaching roadways. Dean Sandoval wrote:

“I believe that the special provisions or plans should state that the contractor "shall install the devices at an elevation to be determined in the field" or "by the Engineer". My reasoning is due to my field experience and encountering several instances where the contractor built the bridge, then paved (asphalt or concrete) to within approx. 50' +/- of the bridge and then

installed the expansion device according to the plan specified elevation. The problem is that the bridge never seems to be exactly the grade specified and neither does the approach asphalt/concrete. I feel that prior to installing the expansion device, the contractor should be required to report as built grades to the Engineer and an elevation of the device determined from that data. In addition, I feel that the device should be installed at an elevation higher than a "straight" grade elevation between the two points mentioned to allow for some settlement.....say **at least** once inch as they always settle.....always! Vertical curves and roadway geometry create other obstacles, but in general that specification would be beneficial. Obviously the amount we raise the device would be evaluated so as not to create a severe bump. Another issue that makes this topic a little more complicated is when you throw in MSE walls and their potential settlement. I believe the Panel Facing is a better construction practice, easier to build and achieve compaction, and is more stable than the Block Facing in deep fill areas.”

3. BRIDGE APPROACH SETTLEMENT PROBLEM: CAUSES AND FORENSIC INVESTIGATION

3.1 Overview

The main cause of uneven settlements in typical bridge foundation systems is the use of different foundation types. That is, while the approaching roadway structure is typically founded on compacted backfill soil, the bridge abutment is typically founded on stronger materials by deep foundations that often experience minimal settlements. Hence, the approach settlement problem at the sleeper slab (approach slab expansion joint) is the main cause of the bridge bump problem. The settlement of the sleeper slab results from the settlements of: abutment backfill (usually four feet), embankment soil and foundation soil. This chapter provides detailed descriptions of various causes of the bridge approach settlement problem at the sleeper slab and the information needed in the forensic investigation to identify the causes and sources of this problem. Discussion is presented to aid in determining if the settlement problem has more or less ended or if significant settlement potential remains.

3.2 Causes of Soil Settlement at the Sleeper Slab

Causes of the bridge approach settlement problem are:

- I. Compression (settlement and lateral movements) of the fill material. Significant compression of the placed fill material occurs due to the presence of
 - a. Compressible fill material (e.g., very loose to medium dense granular soil layer, very soft to medium stiff clay layer). Soft fill can result from placement of a loose fill material not meeting the construction requirements for compaction (construction problem, see construction timing discussed next) and/or from excess water infiltrating into the fill that may cause softening, collapsing, and erosion of the soil (discussed later).
 - b. The loads applied on top of the fill (e.g., traffic load and dead load of the pavement).
 - c. Continuous expansion or elongation and contraction of the bridge decks and girders due to daily and seasonal changes in air and superstructure temperatures. This is a more

critical factor with the use of integral abutment bridges, where abutment walls are rigidly attached to the superstructure without joints. This issue will be covered in great details in Chapter 6 for the Founders/Meadows structure.

- d. Design problems of the wall leading to lateral facing movement of the side walls (sliding, overturning, bearing capacity, or slope stability problems). Lateral movements of the reinforced soil mass in MSE walls are needed to mobilize the tensile resistance of the tensile reinforcements. Additional facing movements in MSE walls may occur due to internal design problems of the facing and reinforcement.
- II. Settlement of the foundation soil layer due to the presence of compressible soil layers (e.g., very soft to medium stiff clay layer), and the load applied on the foundation soil layer. The load includes the additional fill placed above the original ground level and the load applied on the fill (e.g., pavement dead load and live load from traffic). The presence of a compressible foundation soil layer may not be detected in the subsurface geotechnical investigation (location and timing of subsurface investigation are important as discussed in this chapter and in Chapter 5), or if detected, not properly accounted for in the settlement predictions. Introducing excess water to the foundation soil layer can also soften the foundation soil layers as will be discussed later.
 - III. Creep with time under constant load. Under constant applied loads, some materials continue to creep, the process is also called secondary consolidation. Organic and clay soils are more vulnerable to creep than granular soils. Loose granular materials with uniform shape particles have a tendency to creep.
 - IV. A granular fill supporting the sleeper slab may also be susceptible to vibration-induced settlements that are time dependent, especially if the granular fill is loose and uniformly-graded. Vibration and pounding due to the truck traffic over a bridge approach having a bump could densify the granular fill placed immediately beneath the sleeper slab. Repairing the damage and restoring the roadway surface to its original grade would help to alleviate dynamic loading of the approach embankment/fill.
 - V. Construction problems in the elevation grades of the bridge deck and approaching roadways. A bridge bump would be generated at the end of construction if the elevations of the as

constructed bridge and approach roadway deviate from the plan elevations. This major cause was addressed in the previous chapter (Section 2.11).

VI. Problems with bridge expansion joints and surface and internal drainage systems. Joints allow for infiltration of water to fill soil under the sleeper slab. Also, closed joints are often encountered in our bridges that cause the crushing and cracking of neighboring concrete, which allows for leakage of water. Cracks are often noticed close to the expansion joint. There is some evidence that the concrete roadway creeps and grows with time and may close the typical 0-4" Bridge Expansion Joint often employed above the sleeper slab (see Chapter 2 and Figure A.6, see also the last section of Chapter 6). This may explain why some joints are closed even during the winter season. CDOT Region 6 maintenance spent annually around \$500, 000 to replace the old type of bridge expansion devices that has service duration of less than 15 yrs.

Surface water leaking through joints and cracks softens the soil under the pavement. Once present in the soil, it may find a way to exit and usually takes fill material (especially fines) to the sides, leading to loss of fill and erosion problems. This also creates voids under the approach and roadway slab. On some bridge approaches there are no drains present. The water will drain off the approach on the shoulder of the road and may start to erode the soil. This in turn undermines the approaching roadway. Some drains become plugged because the openings are too small. *In many cases, we do not see water coming from the drainage pipes, which is indicative of some problems with these pipes.*

Dennis Rhodes from R6 Maintenance Office summarizes his opinion of possible causes for the continued bridge bump problem in bridge approaches constructed before and after 1993. He wrote "I believe that most of the problem is associated with compaction well below the concrete slabs, but sometime it is erosion caused by cracks and water leaking through, plus poor drainage" and "The higher the fill the more the settlement problems."

3.2.1 Influence of Moisture and Temperatures Changes

During the wet season in Colorado, additional water is introduced to the soil mass (fill and foundation). Surface water can penetrate through poor joints and cracks to the lower soil layers and groundwater can rise in the upper soil layers. Several surface and subsurface drainage control measures are often implemented in the construction project to collect and drain this water. The failure of these measures will result in an increase of the soil moisture content and possibly rise of the GWT. In retaining walls, this increases the lateral earth loads and decreases the soil strength (due to decrease of the soil effective stresses). This will reduce the overall factor of safety against stability and increase movement of the wall. *This is a very important factor in MSE walls* because the excess water will also reduce the friction resistance between the soil and reinforcements, which is the primary source for stability of MSE walls. Large fluctuations in groundwater levels could induce settlements in foundation soils as often reported in the literature.

Increase of excess water in soils will lead to settlement of soils either by

- Erosion or loss of fines from the fill and embankments material via surface water intrusion.
- Softening (decrease of stiffness) or collapse of the soil. This will be discussed next.

Unsaturated silty and clayey soils derive part of their strength from the presence of soil suction (increased level of effective stresses) that leads to apparent soil cohesion and stiffness. This apparent cohesion is highest under the dry state. Dried silty and clayey foundation and fill soil materials will look stiff and this will even be reflected in the test results like the standard penetration test for foundation soils and the nuclear density test for fill soils. As soil moisture increases, the apparent cohesion and stiffness of the soil will decrease (soil effective stress decrease) and the apparent cohesion dissipates completely when full saturated conditions are reached. This will soften the soil material. This is also valid to a lesser extent for granular soils. Compaction of clayey or silty soil fill materials produces high negative pore water pressures (suction) that later may dissipate. In a research study concluded recently by CDOT (Nusairat et al., 2004), it was found that saturation of cohesive compacted soil samples resulted in reduction

of shear strength of the soil by almost 50%, when compared to the shear strength obtained from the partially saturated soil samples. The increase in water content will soften the soil and in most cases will exaggerate the soil settlement problem. In highly plastic natural and compacted clayey soils (CH) located at shallower depth, the soil may expand when wet and subsequent drying of such soils could lead to shrinkage and settlement problems.

Seasonal and temperature changes have a great influence on the induced movements of earth structures. Abu-Hejleh et. al. (2001) found that the front Founders/Meadows MSE wall constructed during the fall/winter season experienced a rigid response during the cold/dry season, and flexible response with relatively large deformations during the warm, wetting, and thawing seasons (April to June in Colorado). For an embankment constructed during the winter season along SH 36, CDOT Maintenance observed sudden and rapid settlement of the newly constructed embankment once the ground thawed in late spring. This was attributed by Allen (2004) to localized consolidation of the embankment materials. According to Allen (2004), an apparent cohesion developed in a soil mass with frozen ice under very cold temperatures that temporarily increases the strength and stiffness of the soil mass. Mr. Mike McMullen wrote “.....as a point of interest we did a repair last year of a moderately severe settlement problem on US 6 that geology attributed to placement of frozen fill.” The presence of ice lenses in the soil mass also leads to false and low soil density readings taken with the nuclear density gages. This apparent cohesion goes away when temperatures rise and ice melts. Also, Abu-Hejleh et al. (2001) attributed the excessive deformation of an MSE earth pier to construction of the pier during the cold season with a lower fill compaction level that led to significant softening of the fill during the subsequent spring season when the temperatures rose and the soil was exposed to excess water from heavy rain and ice melting.

Collapsible soils consist predominately of fine sand and silt size particles arranged in a loose structure (honeycomb with voids) and held together by cementing agents such as clay to calcium carbonate (Coduto, 2001). As long as the soil remains dry, these cements produce a strong soil that can support large loads. However, if the soil becomes wet, these cementing agents weaken and the honeycomb structures collapse (referred to in the literature as hydroconsolidation or hydrocompression). These are mostly naturally occurring soils: alluvial, colluvial, and aeolian

soils. To mitigate the collapsible problem in natural soils, it is recommended to wet or compact the collapsible soil. Coduto (2001) also reported that very loose fill soils will collapse upon wetting even at low normal stresses, but denser soils will be collapsible only at higher stresses. Coduto (2001) also reported the collapse of deep compacted fills even when they have been compacted to traditional standards. Coduto indicated that this phenomenon is likely to occur in soils that are naturally dry and compacted at moisture contents equal to or less than the optimum moisture content. This problem can be reduced by compacting the fill to a higher dry unit weight at moisture content greater than the optimum moisture content.

In summary, both granular- and fine-grained soils can (fill and foundation soils) experience settlements under an increase of their water contents and temperatures. Such settlements will cease or be reduced significantly after the soil moisture and temperature are increased to relatively high values. Therefore, for fill soils with potential for softening/collapsible and even swelling/shrinkage as a result of changes in moisture changes, it is often recommended in the literature to compact the soil wet of the optimum or even to soak the soil with water. For foundation soils), the influence of fluctuations in groundwater levels should be accounted for in the foundation settlement analysis. The conventional consolidation test can be used to assess the soil potential for softening/collapsible/swelling under changes of moisture content as will be demonstrated later.

3.3. The Forensic Investigation: Needed Information

The purpose of the forensic investigations performed in this study is to identify the causes and sources of the significant approach settlement problem and determine if this settlement has more or less ended or has significant settlement potential in the future. The results of this investigation can then be employed to develop an effective plan for repair and mitigation of the settlement problem.

This section presents the three categories of information collected in the forensic investigation *performed in this study* (results are in Chapter 5). Results of the forensic investigations for bridge

structures that experienced significant approach settlement problems are presented in Chapters 4 and 5.

3.3.1 Design, Materials, and Construction Records of the Bridge Approach Structure

Most, if not all, of the following information can be obtained from the construction plans and foundation report for the bridge structure under investigation.

1. Age of the bridge.
2. Location of the bridge (this covers the environmental factors like temperature cycles and intensity of rainstorms, and field factors).
3. Traffic load, truck load, and speed limit.
4. Is the bridge a new or a replacement of an older bridge? If the bridge replaced an older bridge, was the bridge widened? What is the height and location of any added fill above the level of original ground? If the fill height could not be obtained, the study attempted to get information on the bridge height above the level below (roadway or creek).
5. Location of the flowline.
6. Types of abutment backfill material. Construction requirements and construction timing for placement of the fill materials. Timing of the subsurface geotechnical investigation and information on the foundation soils.
7. Length of approach slab. Is the approach slab on a horizontal or vertical curve? Is it on a steep gradient? Type of foundation system supporting the abutment (pile or shaft). Type of the abutment (integral or not), girders, approach joints, and external and internal drainage system.

The construction plans and the geotechnical reports for the bridge should be reviewed to: 1) locate some, if not all, of the information listed above and 2) plan efficiently the geotechnical subsurface investigation. For example, information on the location and thickness of added new fill soil and on the location and conditions of the foundation soil layers can be easily collected from these two resources. Any relevant information listed in the geotechnical report should be

presented. The study also attempted to collect information on the construction timing of the fill material and timing of the field geotechnical investigation. These two are important factors as will be discussed later.

3.3.2 Level, Location, and Time progress of the Approach Settlement Problem

- Location, magnitude, and time progression of the settlement (or bump) problem. A digital road profiler was used in this study to draw current elevation profiles of the transition section from bridge deck to approaching roadway. When these profiles are compared with the design or as-constructed elevation profiles, the level and location of the approach settlement problem were identified.
 - Is the problem limited to one or two sides (east or west, north or south) of the bridge?
 - Is the problem more along the flow line of the bridge?
 - Is there any correlation between the location of the approach settlement problem and height of the added fill and height of the bridge?
 - Is the problem uniform or does it change across the approach slab: is it more severe at one side or at center of the bridge than at other locations?
 - The time progression of the settlement problem since it was first noted. For example, was the settlement problem noticed within a year after construction and then stopped, or have the settlements continued to occur with time.
- Condition of the sidewalls resting above and below the approach slab and approach roadway (settlement, lateral deformations, and damage to the sidewalls). Any available information on the location of the problem and changes of its level with time is obtained.
- Condition of the approach slab (cracking, breaking) and joints located on the approach slab.
- Condition of the bridge external and internal drainage system, drainage inlets, and any signs of erosion around the approach slab, bridge abutment, and embankment slopes.
- Digital picture showing the settlement problem.

It is important to find out if the settlement is a continuous (time-dependent) settlement that will grow in the future, or to a lesser extent, is developed within a year after construction and then ceased. If the problem developed within one year of construction and arrested after that, it should not be of concern, and can be attributed to:

- Short-term settlement of sleeper slab due to traffic load, due to seasonal changes, and due to presence of some silty materials in the foundation soils, or limited fluctuation in the groundwater table.
- Construction problems like lack of adequate compaction, or construction timing, like placement of backfill during the winter season, or other construction issues. For example, when one side of the bridge settles and the other does not, and if both sides have similar field and loading conditions, then the problem can be attributed to construction problems.

3.3.3 Subsurface Geotechnical Investigation

The purpose of the subsurface geotechnical investigation performed in this study (see chapter 5) was to determine the location, classification, strength, compressibility, and moisture content of fill (abutment and embankment soils) and foundation soil layers.

Overview. Based on the results of the previous task, the bridge side with the most severe settlement problem should be identified and selected to conduct the geotechnical investigation. Two test holes were drilled around the sleeper slab that experienced settlement: one in the approach slab toward the bridge, and the other on the roadway side. Test holes were advanced using a 7-1/2-inch diameter hollow stem auger (HSA) or 4-inch diameter continuous flight power auger. The most common field sampling and testing procedures used in Colorado are the standard penetration test (SPT) method in accordance with ASTM D1586 and the California Sampler (see Abu-Hejleh et. al., 2003 for complete details of these techniques). With these two techniques, driving resistances (N-value or # of blows to drive 12”) of the soil at different depths of the same hole were obtained and samples were recovered for visual inspection and lab testing. Laboratory testing results included gradation (e.g., % of gravel, % of sand, and % of fines: silt and clay) and Atterberg Limits (LL for liquid limit and PI for plasticity index). These results were used to classify the geomaterial by both AASHTO classification (e.g., A-7, A-6) and the

Unified Classification System (e.g., CH and CL). From the soil samples recovered with the California sampler, measured data on the insitu soil dry density (γ_d) and moisture content (w) were measured. The presented logs summarize the locations and types of recovered soil samples, locations and results of the driving resistance values (e.g. N-values from SPT), and locations of the GWT. Measured driving resistance values (N-values) and measured density values are employed to describe the relative density of granular soils and consistency of cohesive soils as per CDOT guidelines described in a previous chapter.

Problematic soil layers in the fill and foundation soil layers. They are identified as those with N-values less than 10 bpf for granular soils (described as loose to very loose) and those with N-values less than 8 bpf for cohesive soils (described as very soft, to soft to medium stiff). One interesting way to find out if a compressible soil layer exists immediately below the sleeper slab is to visually note any detectible movements of the sleeper slab when a truck leaves the bridge or the roadway and drops onto the approach slab.

In the problematic fill layers, the required and placed compaction levels were determined. Auger cuttings for materials recovered from these layers were used to develop moisture-density curves from Proctor testing in accordance with AASHTO T-99 (standard Proctor test) or AASHTO T-180 (Modified proctor test). For the granular soils, information on the uniformity of the gradation (e.g., well-graded or poorly graded) and if the soil particles are uniform or crushed were determined. Note that it is reported that loose granular materials with uniform shape particles have a tendency to creep. Natural dry unit weights and moisture contents measured from the California and Shelby tube soil samples were compared with the required density values and the optimum moisture content measured from the moisture-density curves. Note that the measured soil dry density levels reflect the conditions after some level of densification occurred over time and not necessarily the placed density levels immediately after construction completion.

Consolidation characteristics of the problematic soil layers were also investigated. In most cases, Shelby tubes were pushed into the soft soil layers to retrieve undisturbed soil samples. Laboratory consolidation tests (AASHTO T 216) were performed on the recovered soil samples. The compressibility of soils can be estimated through the ratio of $C_c/(1+e_0)$, where C_c is the

consolidation compression index, measured as the slope of the virgin consolidation curve (void ratio vs. log vertical effective stress) and e_0 is the initial void ratio. The coefficients of consolidation, C_v , and coefficients of secondary compression or creep, C_α , were also measured at different ranges of effective stresses. In most cases, water is added at the beginning of the consolidation test to saturate the samples and allow for testing under the worst possible field scenarios- water softens the soil and increases its compressibility and/or causes it to collapse. Then, the predicted consolidation settlement will reflect the total settlement resulting from the increased applied vertical load and from increases of soil moisture content to 100% saturation level and from an increase of temperatures, if the soil in the field was placed under very cold conditions. However, the time rate of settlement in the field may not be as predicted using the coefficient of consolidation, C_v , measured in the consolidation test but could be delayed until the soil is subjected to 100% saturation conditions and normal warm temperatures. Initial saturation of the sample also allows for measuring the swelling potential under the lowest top surcharge effective stress.

Judgment and evaluation of the measured field soil moisture contents, saturation levels, optimum water contents, and relative compaction levels were employed to determine if there is any potential for future softening or collapse of the problematic soil layers. If the bridge structure with settlement problems has been in service for several years, then most likely the underlying soil (fill and foundation) layers were subjected to their highest possible water content (and temperatures) and chances for further softening or collapse are minimal. When future soil collapse or softening potential are suspected, the soil specimen was tested in the consolidation test under its current in-situ moisture to a vertical effective stress equal to or slightly higher than that which occurred in the field (Coduto , 2001). Then, the sample was inundated to measure the resulting hydrocompression strain for this overburden stress (Coduto, 2001). Once the hydroconsolidation ceased, additional stress increments were applied as in the conventional consolidation test procedure.

4. PERFORMANCE AND COST-EFFECTIVENESS ANALYSIS OF CDOT'S FLOWFILL AND MSE BRIDGE APPROACHES

4.1 Overview

This chapter presents results for the evaluation and comparison of the performance and cost-effectiveness of bridge approaches constructed by CDOT with abutment flowfill backfill and abutment MSE backfill (Class-1 and Class B Filter materials). In these bridge structures, the abutment walls were supported by deep foundations (not like the Founders/Meadows structure discussed in Chapter 6). This chapter also presents common features of the excellent and problematic approaches and possible causes and sources of the settlement problem in the problematic approaches (per the guidelines established in Chapter 3). The performance and cost information furnished in this chapter were obtained from: inspection records collected by the CDOT Bridge Management Section, input from CDOT's Regional Maintenance Offices, and field visits. Detailed investigations of the causes and sources of significant approach settlement problems encountered in five bridge structures constructed with abutment flowfill and MSE backfill material are presented in the next chapter.

The best way to compare the performance of MSE and flowfill backfill materials is to construct them side by side at the same bridge. In this manner, causes of the settlement problem discussed in the previous chapter, except the abutment backfill, will be similar. Only two CDOT bridge structures with side-by-side flowfill and MSE approaches could be found in this investigation and their performance is discussed in Section 4.2. All other CDOT bridges were constructed with either flowfill or MSE backfill materials under different field and loading conditions. The study evaluated the performance and cost of: 1) a large number of approaches constructed with flowfill backfill, and 2) a large number of approaches constructed with MSE backfill. It is assumed that the use of sufficiently large number of MSE and flowfill approaches will balance all other factors that influence the performance, except those related to the abutment backfill, thus allowing for comparison of the performance and cost of MSE backfill vs. flowfill backfill. The study procedure for evaluation and comparison of the performance and cost of bridge approaches

constructed with flowfill and MSE backfill materials is described in Section 4.3, and the investigation results are presented in the remaining sections.

4.2 Performance of Side by Side Bridge Flowfill and MSE Bridge Approaches

In the Big Thompson Canyon in Region 4, construction of two new bridges, C-15-O (MP 68.75) and C-15-U (MP 70.58), was completed in May of 2002 (see Figure C.16). These bridges are located along SH 34 that runs east-west between Loveland and Estes Park. These two structures were built in two phases. In Phase 1, the northern sides of the two bridges were constructed using MSE abutment backfill. In Phase 2, the southern sides of the two bridges were constructed using flowfill abutment backfill. So, each abutment of the two bridges has both types of backfill side by side. Mr. Pete Graham was the CDOT Project Engineer for the construction project.

The two bridges were inspected on May 24, 2004; almost two years after the bridges had been in service. Pictures of the approaches were taken (Figure C.16). The development of differential settlement along the east side of C-15-U bridge was evaluated using a digital road profiler. Digital profiling data were collected (Figure 4.1) along two lines located along the north side of the bridge (where flowfill abutment backfill was used) and the south side of the bridge (where MSE abutment backfill was used). Note that the profiled lines are located on a horizontal curve (i.e., the bridge abutment is not perpendicular to the bridge centerline), so the two profiles should *not be expected to match*.

The visual observations and the results shown in Figure 4.1 suggest that the transition between the bridge and approaching roadway after almost two years in service is smooth and shows no signs of developing a bridge bump problem. Thus, we can conclude that the two systems of abutment backfill are performing well so far with comparable performance.

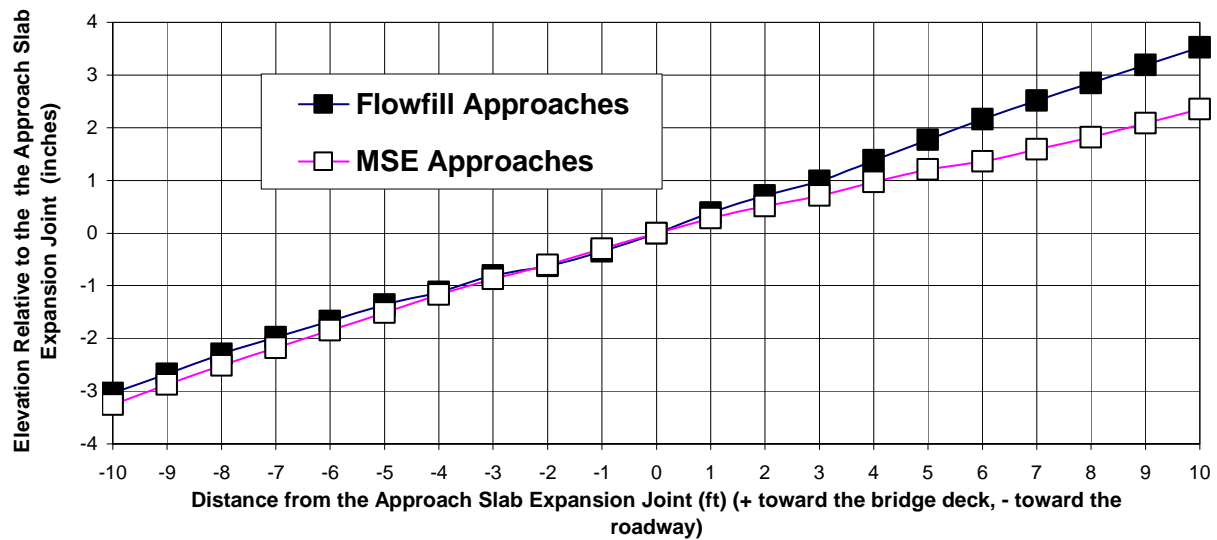

Figure 4.1. Measured Elevation Profiles for Structure C-15-U Where Side by Side Flowfill and MSE Approaches Were Constructed.

4.3. Procedure for Evaluation of Performance and Cost-Effectiveness of Flowfill and MSE Bridge Approaches

A list of all CDOT new bridge approaches constructed with concrete approach slabs since 1990 were obtained from the Bridge Management Section. From the information published by CDOT Engineering Estimates & Market Analysis Unit, projects that included the use of flowfill and MSE abutment backfill materials were identified. By merging the information collected from both sources, CDOT bridge approaches constructed with a concrete approach slab and either flowfill abutment backfill (Table B.1) or MSE backfill (Table B.2) were identified. A total of 110 bridges were constructed with flowfill abutment backfill from 1993 to 2001 (none could be found in 2002 and 2003). A total of 23 bridges were constructed with MSE abutment backfill (Class 1 and Class B) from 1999 to 2003 (none could be found before 1999). The bridges in Tables B.1 and B.2 are sorted based on the time of completion of bridge construction. Other Information obtained from the Bridge Section included the bridge log number, location of the bridge, name of the designer and contractor, name and number of the construction project, number of spans and type of girders, and number of bridges in every project. Information obtained from the Engineering Estimates & Market Analysis Unit included the bid date, quantity,

cost, and total costs of flowfill or MSE backfill used in the project. Some (not all) of this information is listed in Tables B.1 and B.2. Colorado is divided into six regions and most of the bridges in Tables B.1 and B.2 are located in Regions 1, 2, 4, and 6, so the study focused on bridges constructed in these regions. The 10 bridges with the worst approaches are listed in Table B.3. It is clear from this table that most of the worst bridge approaches are located in Region 6 that includes Metropolitan Denver. This is expected since Region 6 carries most of the state traffic load.

For MSE and flowfill bridge approaches, the study collected information on their performance and cost (construction and expended repair costs). For existing bridge approaches with less than satisfactory performance, the study attempted to collect information on the possible causes of the settlement problem and any required repair costs to bring their performance to an acceptable level.

4.3.1 Performance from Records of CDOT's Bridge Management Section

CDOT's Bridge inspectors perform inspection of all components of the bridges including approaches and rate them following Pontis Bridge Inspection Coding Guide that can be accessed online at <http://www.dot.state.co.us/Bridge/Pontis/pontiscovers.pdf>. CDOT's Bridge inspectors inspect the bridge approaches every two years. Element 321 is for inspection of concrete approach slab that may or may not have an asphalt overlay, placed either during construction of the bridge or applied later for repair purposes (to smoothen the approach when there is a settlement problem). The Bridge Inspectors assess the overall condition of the bridge concrete slabs. This provides insight into the approach settlement problem. Four condition states are used by CDOT's Bridge Inspectors to describe the condition of the concrete slabs:

- Condition State 1. The slab has not settled and shows no sign of deterioration other than superficial surface cracks or minor break-up. This condition state is categorized as the best.
- Condition State 2. Minor cracking, spalls may be present but they do not affect the ability of the slab to carry traffic. Settlement may be occurring which increases the traffic impact on the bridge.

- ❑ Condition State 3. Cracks may extend completely through the slab cross-section, but the slab does not act if it is broken. Spalls may be heavy but they do not affect the structural integrity of the slab. Settlement may be occurring which increases the traffic impact on the bridge.
- ❑ Condition State 4. The slab is broken or rocks under traffic loads. Settlement is excessive and cannot be corrected without increasing the size or replacing the slab.

4.3.2 Performance Based on Bridge Approach Settlement

Ratings for different bridge approaches were developed in this study to reflect the range of settlement experienced by the bridge approaches *at the expansion joint (or sleeper slab if no joint was employed)*. Three states are used in this study to rank the bridge approaches in accordance with the following rating system:

1. No to very slight bump problem (smooth approach, the best rating). The sleeper slab (or approach slab expansion joint) has experienced a minimal settlement less than a tolerable settlement of 1 inch. Note that NCHRP Synthesis Report (1997) indicates that a change in the slope of the approach slab of 1/200 is tolerable and for an approach longer than 15 ft, this corresponds to a settlement at the expansion joint (or sleeper slab) larger than 0.9". This rating is categorized as the best.
2. Slight to moderate bump problem. The sleeper slab has settled more than 1 inch and less than 2 inches. This condition is categorized as a slight problem for relatively long approach slabs (>25 ft) and/or when the speed limit is low (<40 mph) to a moderate problem for relatively short approach slabs (<20 ft) and/or when the speed limit is high (>50 mph). If one side of the bridge is rated 1 and the other side is rated 2, the overall rating of the bridges approaches is taken as 1.5.
3. Significant to large bump problem. The sleeper slab has settled more than 2 inches. This rating is categorized as a safety hazard if the settlement is larger than 3 inches.

For structures ranked 2 and 3, the study attempted to obtain information on the location and extent of the approach settlement at each end of the structure and if the settlement is a continuous

(time-dependent) settlement that will grow in the future or developed within a year after construction completion and then ceased.

4.3.3 Information on Applied and Required Repair Measures

When a low approach or a bridge bump is first noticed by maintenance forces, a leveling asphalt layer, either hot or cold depending on outdoor temperature, is often applied on the approach slab and adjacent roadway and bridge deck to smoothen the transition area. If this was not effective, and depending on the condition and rating of the approach slab and the assessment of CDOT Maintenance, Bridge, and Geotechnical Offices, one of the following two methods are often undertaken:

1. Removal and replacement of approach slab and in some cases the backfill material supporting the slab (Most expensive).
2. Stabilizing the soil and raising the sleeper slab using either mud jacking method (just stabilizing the soil), high-pressure compaction grouting, or the Uretek “foam” method. These methods are described in Chapter 2.

The inspection and rating results presented in this chapter, based on the criteria presented in the previous two subsections, are for the current conditions of the approach slabs that may or may not have been repaired. Repair of the bridge approaches will improve the conditions, and thus the rating of the bridge approaches. If repair measures were applied on any bridge approach, the study attempted to acquire information on the type, timing, and cost (most important) of these repair measures. Any available information on the performance of these repair measures is also documented. For bridge approaches that need repair, rough estimate of the required repair costs to produce a smooth approach that could be rated 1 are also obtained and documented.

4.3.4 Cost-Effectiveness Analysis of Flowfill and MSE Bridge Approaches

The cost-effectiveness of bridge approaches constructed with flowfill and MSE backfill were evaluated in accordance with the following procedure:

- I. Determination of the 2005 construction costs of bridge approaches. The 2005 average unit construction cost of the abutment backfill materials (Class 1, flowfill, or Class B) was employed to represent the unit cost of the approaches.
- II. The volume of placed abutment flowfill and MSE backfill materials were obtained. It was not clear if the reported quantities in Appendix B for the backfill materials under item 206 were only placed behind the abutment as abutment backfill or also used for other purposes. To be more accurate, it was assumed that 200 CY were placed for each approach or 400 CY for a bridge with two approaches. This value is believed to represent a very good average value.
- III. The average number of years of service for bridge approaches constructed with flowfill and MSE (Class 1 or Class B) backfill was obtained. Service life for a bridge is often assumed as 75 years, but for bridge approaches the service life is very much related to the life of the joint. Dr. Trever Wang of Staff Bridge suggested a service life of 40 years for the bridge approaches. A ratio between 40 years, assumed to be service design life, and the average number of service years was then calculated.
- IV. Expended 2005 costs to repair the bridge approaches constructed with flowfill and MSE backfill were obtained.
- V. Any required 2005 expenses to repair the MSE and flowfill bridge approaches and smoothen them (so they could be rated as good) were also estimated.
- VI. The total 2005 repair costs from the previous two items were added. This total repair cost was divided by the amount of placed backfill determined in Step 2 to calculate the 2005 unit repair cost that was added to the unit construction cost to determine the *current total* 2005 unit cost of the backfill. This total 2005 unit cost represents **a lower limit estimate of the unit cost** over the entire design life of the structure if no repair will occur in the remaining service life of the structure.
- VII. Assuming that the same rate (or trend) of repair costs incurred in the past will be incurred in the remaining service life, the current total 2005 unit repair cost estimated in the previous step was multiplied by the ratio determined in Step III. This represents the 2005 unit repair cost of the bridge approaches over their entire design life of 40 years. This unit repair cost was added to unit construction cost determined in Step 1 to obtain the total

(construction and repair) 2005 unit cost of backfill over their entire design life. **This total unit cost could represent an upper limit of the total unit cost of backfill** over their entire design life if the rate of future repair costs will not exceed the current rate of expended and required repair costs.

The two unit costs evaluated in the last two steps allow comparing the cost of bridge approaches constructed with flowfill and MSE backfill materials having equal performance. With more structures constructed with MSE backfill and with longer service life, a more sound and scientific comparison of the two systems could be made and the range between the two total unit costs in subsequent years (e.g., 2010) is expected to narrow down.

4.4 Region 6 Bridge Approaches

In Region 6, a total of 37 bridges were constructed with flowfill backfill materials (76 approaches), 2 with MSE Class 1 backfill, and 5 with MSE Class B backfill. A list of these bridges and detailed performance inspection results for each structure are given in Table B.4. The 10 bridge structures that have best approaches and the 10 bridge structures that have worst approaches are, respectively, listed in Tables 4.1 and 4.2. For the 10 bridge structures with worst approaches, Table 4.2 summarizes location of the bridge, type and cost of any placed repair measure, and cost of any required repair work to bring the performance of the approach to an acceptable level. It was noticed that most of the problematic bridge approaches are located in the north central and north east zones of Region 6 (Along I-76 around and north of the I-70/I-25/SH36 Intersections) where the traffic load is very high. In addition, a landfill was present there with very soft foundation soils that may have been used in the construction of the fill for bridges and roadways. Also, most of the problems occurred to the older bridge approaches constructed in 1994 when CDOT started using the flowfill.

Table 4.1. The Ten Bridges with Best Flowfill Approaches in Region 6.

Rating	Bridge	Hiway	Mile Pt.	Built	Hiway carried	Location
1	E-16-PM	70	269.45	1995	I 70 ML WBND	ARVADA
1	F-16-RY	285	257.19	1995	US 285 ML	0.65 MI E OF SH 95
1	E-17-VT	224	0.49	1998	I25 NBND TO SH224	I 25 NBND & SH 224
1	F-17-MG	25	202.64	1998	I 25 ML	IN DENVER
1	E-16-NF	93	6.95	1999	SH 93 ML	0.6 MI S. OF JCT. SH 72
1	E-16-PY	6	271.68	1999	US 6 ML	IN GOLDEN
1	E-17-MX	2	18.70	1999	SH 2 ML	0.3 MI S. OF JCT I 76
1	E-17-UH	2	18.83	1999	SH 2 ML	.2 MI S OF JCT I76
1	E-17-UQ	70	274.71	2001	RAMP TO I 70 EBND	DENVER
1	E-17-WP	266	3.308	2000	SH 265 ML	COMMERCE CITY

Table 4.2. The Ten Bridge Structures with the Worst Flowfill Approaches in Region 6.

Bridge	HW	Mile Pt.	Built	Location	Rating	Date, Type and Cost of any Repair	Approximate Required repair costs
E-17-PQ	76	19.2	1994	Buckley over I-76	2	1998, Replace approach slab and use of drilled shafts, \$172,000	\$20000
E-17-PR	76	19.7	1994	136 th over I-76.	3	Mudjacking, \$10,000	\$172,000 (remove and replace)
E-17-SW	225	12	1994	Denver	3	\$24,000 for Urettek repair of departure approaches.	\$50,000 for Urettek repair of arrival approaches.
E-17-PS	76	20.9	1994	3.5 mile of JCT 51	1	Mudjacking, \$10,000	Roughly \$40,000 for Urettek repair
E-17-PT	76	20.9	1994	3.5 mile of JCT 51	1		Roughly \$40,000
E-17-VR	44	1.08	1996	104 th over I-76	2	\$1000 for adding asphalt in 2005.	Urettek to stabilize the fill only, \$30,000.
E-17-QA	270	0.01	1994	INT. 36 & 25	2		\$30,000 for the east side only.
E-17-QO	270	0.04	1998	0.3 mile east of I-25	2		\$60000 for repairing two sides of the bridge.
E-16-RB	36	55.9	2001	Westminster	1		
F-16-LZ	70	263	1996	0.9 mile of Jct US 40	1		

Structure E-17-PQ (Figure C.7) was constructed in 1994 using flowfill abutment backfill. This structure experienced a significant approach settlement problem especially along Abutment 1 (south side). A construction project was completed in 1998 to fix the settlement problem that included complete removal of the approach slab and removal of parts of the flowfill at Abutment 1 that were replaced with a new approach slab and Class 1 backfill. Also, the slope paving was repaired and 4 new bridge drains were installed. As illustrated in Figure 4.2, a drainage layer with drain pipe was placed beneath the sleeper slab. As also shown in this figure, nine drilled

shafts (600 mm in diameter) spaced 3.145 m and embedded into the embankment to a depth of 7.5 m were used to provide support to the sleeper slab. Total costs of this repair project were \$171,681.98. Inspection of the bridge in 2004 revealed the existence of a noticeable bridge bump problem (See Figure C.7). After talking to Mr. Rene Valdez from Region 6, it was concluded that this problem was left at end of construction and that the repair was effective in preventing further approach settlement. By looking carefully through the photo presented in Figure C.7, it is clear that the elevation grades of the approach bridge and approach roadway are not on a straight line (they do not have the same slope) and that the approach slab was placed to connect these two sections. The approach roadway should have been built to match the as constructed grades of the bridge by using string lines that extend to the bridge. It is also suspected that Structures E-17-UZ and E-17-UH were built in similar way with a bridge bump problem left at end of construction. It was also strange that the roadway was high for both structures E-17-UJ and E-17-WZ, this could also be due to a problem left at end of construction.

In the 58th avenue bridge over I-25 bridge (constructed without the use of MSE or flowfill approaches), drilled shafts were employed to support the sleeper slab and repair the approaches. This bridge was inspected on October 23, 2003 and found to function well.

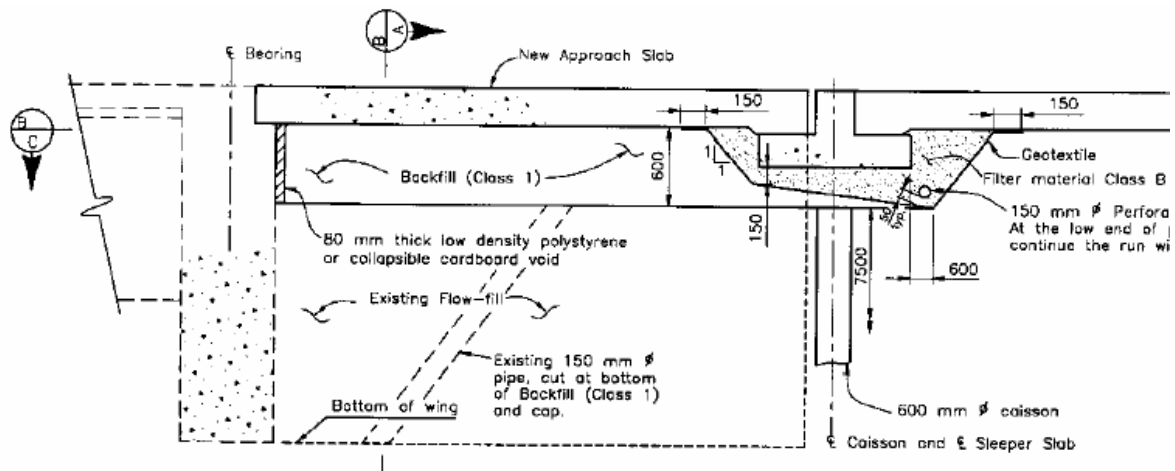

Figure 4.2. Use of Caissons in the Repair of the Bridge Approach Settlement Problem at Structure E-17-PQ.

Structures E-17-PR (Figure C.8) and E-17-SW (Figures C.2 to C.5): for these two bridge structures with approaches ranked the worst, a detailed investigation to identify the causes of the problem was performed and the results are summarized in the next chapter. The approaches for structure E-17-PR were mud jacked for \$10,000. A field visit for the E-17-SW structure indicated that the wall's drainage pipes are clogged (not functioning) as the investigation suggests. The Uretex method was employed to fix the departure approaches of E-17-SW late 2004 and will be used to fix the arrival approaches in the Spring of 2005. For these two structures, the recommendations for repair (see next chapter) included drainage improvements and the use of compaction grouting or polyurethane deep injection.

E-17-PS (Figure C.9) and E-17-PT: The approaches for structure E-17-PS were mud jacked for \$10,000. It seems the mudjacking stabilized the backfill. However, repair may still be needed to straighten the approach slab along this busy and high speed section of I-76. The same is true for the neighboring E-17-PT Bridge.

Structure E-17-VR (Figure C.10): A major settlement problem of the approach roadway (not sleeper slab) was noticed (around or larger than 2") on the western side of the structure. The approach slab is short, around 7' which worsens the problem. This bridge was rated 2 because of very low traffic volume and relatively low speed. Major repair work is needed; perhaps as the Buckley Rd.

Structure E-17-QA (Figure C.11) and E-17-QO (Figure C.12): for these two neighboring structures the east sleeper slab dropped around 2". For Structure E-17-QO, it was noticed though a later visit (February 2005) that the west sleeper had also settled. For Structure E-17-QO, the flow line is located along the north side of the structure and this may explain why the problem was more severe on that side. For structure E-17-QA, it is suspected the bridge bump problem was created at the end of construction as previously discussed.

4.5 Region 4 Bridge Approaches

In Region 4, a total of 24 bridges were constructed with flowfill backfill materials (50 approaches), 2 with MSE Class 1 backfill (4 approaches), and 5 with MSE abutment Class B backfill (10 approaches). A list of these bridges and detailed performance results for each

structure are given in Table B.5. A list of the bridge approaches that were repaired or need repair with information or repair costs are listed in Table 4.3.

Table 4.3. The Region 4 Problematic Flowfill Bridge Approaches.

Bridge	HW	Mile Pt.	Built	Rating	Date, Type and cost of any Repair	Required Repair Costs
C-22-BT	71	181.5	1995	1.5	1" settlement in 1998 to 2" in 2004, (only south side). 1998, Asphalt, \$2000	\$2000
C-21-BM	34	159	1995	1	2" settlement, Corrected with foam in 2002, and it is still in good condition. \$20,000	
C-16-DK	287	323.6	1999	3	\$22,500 (Foam)	\$60,000 (compaction grouting)

B-24-AS, B-24-AT, B-23-A, C-23-AO, and A-27-P: These bridges are located in the northeast section of Colorado and all are rated as 1 or excellent. Mr. Dough Kettelson from CDOT maintenance office indicated that all these bridges replaced older bridges, they are low approaches (I-76 may be the highest), and were constructed by good contractors.

Structure C-22-BT (Figure C.13): Construction for this structure began late winter and finished in the summer of 1995 with a height of 22 ft and a width of 40 ft. The south approach settled 1" by 1998 so asphalt was applied to smoothen the approach. There currently no signs of bulging or soil erosion. North side of bridge in good condition with no problems, so this bridge was rated 1.5.

Structure C-21-BM (Figure C.13) Construction for this structure began in the Spring and finished late summer/early fall of 1995. The approaches had settled about 2". No asphalt overlays were added to fix this problem. The approach slabs on both ends of bridge were repaired in 2002 using the Uretex Method with laser surveying tools to monitor the generated movements. Currently, the bridge approaches look good and this is why they are rated 1 (based

on current conditions). Foam was selected over grouting because upon installation smaller holes have to be drilled to inject foam, and because it is water proof. Ray Terrones from R4 Maintenance Office added “We had several other jobs that were using foam at other locations during the same time. We have had good luck with the foam and are very happy with the results.” This opinion was also shared by Mr. Mike Day from R4 CDOT Maintenance Office who stated: “placing of foam will not only fill the voids but also under seal the area under the slab and prevent further deterioration of the concrete approach slabs. Cost of replacing the slabs is \$75 k to \$100 K, but the foam will cost around \$20 K.” A project engineer in Region 4 wrote: “I don't trust Uretek; they haven't been able to get full support as advertised.” Therefore, there are mixed opinions on the use of this technology and its future evaluation is warranted.

Observations for Structures C-22-BT and C-21-BM

1. *Both bridges experienced settlement within one year of construction.*
2. Both have asphalt approaches, no signs of erosion.
3. All joints are in good conditions.
4. The drainage system is in good condition.
5. For structure C-22-BT, there are no differences between the two approaches to explain the difference in performance (similar height of embankment and exposure to the Creek running water). Hence, the inadequate performance of the south approach is believed to be attributed to construction problems (inadequate compaction or construction during the cold season).

For Structure C-21-BM, the settlement problem could be caused by construction problems as presented for Structure C-22-BT or due to presence of slightly compressible foundation soil.

Structure C-16-DK (Figure C. 6) along SH 287: This structure experienced significant settlement in all four lanes and therefore was ranked 3. There is a severe bridge bump problem (see break in the yellow line of the picture shown in Figure C.6) at this site. This problem is magnified by the high speed limit of 55 MPH. For this structure, with approaches ranked the worst, a detailed investigation to identify the causes of the problem was performed and the results are summarized in the next chapter. It was determined that a soft soil layer is located at a depth of 10 ft and is the main cause of the problem. During the summer of 2004, CDOT

Maintenance tried the Uretex method (or foam) for the deep stabilization of the fill, but it did not work because of the presence of water. CDOT Maintenance will consider compaction grouting for this structure and the repair costs are roughly estimated at \$60,000.

Bridges with Approaches Constructed with Class B Filter Material: D-17-DN, D-17-DM, D-17-CR, D-17-CT, D-17-DY.

Several bridges (listed above) were constructed in 2004 along I-25 north of Denver near the exit to the City of Lafayette. The approaches for these structures were constructed with Class B Filter Material instead of Class 1 Backfill. Other details of the bridge approaches were similar to those for Class 1 except for those listed next. *Expansion Device was placed at the abutment wall which, according to Dick Osmun, is to prevent dragging of the approach slab that could cause the slab to crack. In structures D-17-CR and C-17-T, the drainage details were different than those of CDOT standards.*

Construction personnel complained of the lack of quality assurance methods for placement of the Class B Filter Material because no compaction tests were required for this material as per CDOT construction standard for this material. They reported some settlement possibly due to the use of Class B Filter Material. On May 24 of 2005, these structures were inspected. The PI did not see any solid evidence of major approach settlement problems in these bridges. In the first two bridges, the approach slab at the expansion joint is resting on the bridge abutment, so any settlement there has nothing to do with the backfill or embankment settlement. In structure D-17-DY, the pattern of settlement suggests that the bump was created at the end of construction as discussed before. Recent observations reported early in 2005 suggest some settlement at the four corners of this bridge. *It is recommended in the future to monitor the performance of these structures and to develop a more robust method for the quality assurance of Class B filter materials placed as abutment backfill material. Some suggestions for quality control of Class B Filter Material were furnished in Chapter 2.*

4.6 Region 1 Bridge Approaches

In Region 1, a total of 21 bridges were constructed with flowfill backfill materials (44 approaches), and 2 with MSE Class 1 backfill (4 approaches). A list of these bridges and detailed performance results for each structure are listed in Table B.6.

The Founders/Meadows Bridge over I-25: although constructed with MSE Abutment backfill, is singled out because the abutment was supported by MSE walls not by deep foundations as is the case for other bridges. The performance of this structure is rated as excellent and more detailed discussion on the performance of this structure is presented in a subsequent chapter.

Structure G-22-BX (Figure C.14): no settlement or cracking was noticed along the north end of this structure. The south end settled approximately 2" with about a 1" gap in the joint. The speed limit is low because of approaching an intersection just down the road. The 2" settlement is significant; however it is spread over approx 24 feet in length of approach slab. The approach rides fair because of the low speed and large length of the approach slab. The height of the structure above the creek is around 10 feet. There is one crack opened up about an inch wide in the approach slab, and CDOT Maintenance plans on filling it to keep water out of the base.

According to Mr. Terry Hubbell from CDOT Maintenance the settlement happened shortly after the structure was built and it does not appear to have settled any more for the last year or so. And because the problem occurred on one side, it is expected that construction problems caused the problem as discussed before structure C-22-BT.

According to Mr. Hubbell also, the approach and the structure are concrete so asphalt was not recommended for repair because it is hard to get the asphalt to adhere to the concrete (i.e., it seems to always have a problem with asphalt raveling). He is thinking of using a foam to raise the slab and the expected cost is \$10,000.

E-19-Z (Figure C.15): This structure was constructed in year 2000 with MSE abutment backfill. This structure has significant settlement in all four lanes and therefore was ranked 3. For this structure with approaches ranked the worst, a detailed investigation to identify the causes of the problem was performed and the results are summarized in the next chapter. This structure

was repaired using compaction grouting in June of 2004. The total repair cost was \$68,000. The roadway appeared fine 6 months after the work was completed. Another year or two would give a *much better indication of the performance of compaction grouting.*

4.7 Region 2 Bridge Approaches

In Region 2, a total of 16 bridges were constructed with flowfill backfill materials (32 approaches), and 8 with MSE Class 1 backfill (16 approaches). A list of these bridges and detailed performance results for each structure are given in Table B.7. Region 2 has the largest number of Bridge Structures constructed with MSE Abutment Backfill. Six photos of these structures are provided in Figure C.17. Except for Structure L-18-BD, it seems that the performance of these structures is acceptable. A list of the bridge approaches that were repaired or need repair with information on repair costs are given in Table 4.4.

Table 4.4 The Problematic Bridge Approaches in Region 2 (They all ranked 1 based on their current conditions except Structure L-18-BD ranked 3)

Bridge	Maintenance Comments	Expended Repair Costs
Approaches Constructed with MSE Abutment Backfill- See Figures C.1 and C.17		
J-18-AI	Dropped an inch -- patched – south end only.	\$500
K-18-GG	Problem was fixed during construction	0
L-20-A	Patched- all sides	\$1000
L-18-BD	Ranked 3 and is the only structure that still needs to be repaired in Region 2. Significant Repair costs are expected.	\$50,000
Approaches Constructed with Flowfill Abutment Backfill		
L-21-DA	Repaired twice. First, by roto milling close to the joint. Later a sliding plate was placed on the expansion joint, and plug joint was placed raising the top grade by around 4”.	\$1500
L-21-DB	Settlement of 2” on west side and 1” on side. See details below.	\$1000
I-17-KZ	Added mix once-North end	\$500

Possible Causes of the Bridge Bump Problems for Structures L-21-DA and K-18-GG:

According to Mr. Dean Sandoval from Region 2, a bump was created at end of construction because the expansion joint was placed per the plan grades not based on grades of the constructed bridge and approaching roadways (see Section 2.11 for more details).

L-21-DB (Figure C.1): The bridge was constructed in 1997 in the fall and shortly after construction was completed the west end of the bridge at the approaches settled. It was fixed with 1" of asphalt overlay in 1999. In 2003, both sides were fixed again with 1" of asphalt overlay with costs approximately \$500. No significant settlement since last year so it was ranked 1. Fill height of this structure is around 30 ft. The bridge is new (location is different from the older bridge). There are no sidewalls, no expansion device, no drainage inlets, and there were no sign of erosion to the side embankment. The bridge and approaching roadway are covered with asphalt which allow for cost effective repair for the settlement problem when compared to bare concrete approaches. There is cracking at the joint and approximately 30' from the joint across both lanes. The length of approach slab is around 15 ft. Maintenance could not find any reason for the settlement at this structure and for the differences in settlement between the east side and west side (both have the same fill height) except for possible construction settlement from lack of compaction. However, the fact that settlement continues to occur with time (4 years after fixed the 1st time) may suggest the presence of a compressible foundation soil layer. Also it should be noted that the bridge is new and did not replace an older bridge. This bridge should be monitored in the future if settlement continues to progress with time.

L-18-BD (Figure C.1): This structure was constructed in 2003 with MSE abutment backfill. During and shortly after construction was completed, significant approach settlement and wall bulging problems were noticed. For this structure with approaches ranked the worst, a detailed investigation to identify the causes of the problem was performed and the results are summarized in the next chapter. The repair costs that will be paid by CDOT are estimated as \$50,000.

4.8 Performance and Cost-Effectiveness of Flowfill and MSE Bridge Approaches

The performance and cost-effectiveness data presented in Tables 4.5 and 4.6 are based on limited number of data and service years for MSE approaches and therefore should be considered with precaution. In addition, the performance and repair of approaches are not only controlled by abutment backfill but more related to drainage, construction workmanship, embankment, and foundation soil, as will be discussed in Chapter 5.

The number of bridges considered in the evaluation are 98 bridges constructed with flowfill backfill material (202 approaches), 14 with MSE Class 1 backfill (28 approaches), and 10 with MSE Class B Backfill (20 approaches). A list of these bridges and detailed performance results for each structure are given in Tables B.4 through Table B.7. Performance results for these approaches are briefly summarized in Table 4.5. Results of the cost-effectiveness analysis are summarized in Table 4.6. Findings are:

- ❑ Most of the flowfill and MSE bridge approaches constructed by CDOT since 1993 are performing well, with no settlement or cracking problems.

- ❑ Most of the settlement problems for the flowfill approaches occurred to the older bridge approaches constructed in 1994 when CDOT just started using the flowfill. The 2005 unit construction cost for flowfill is \$76/CY. The estimated total 2005 unit cost of flowfill over their service life of 40 years ranges from \$95/CY if no additional repair costs will not be needed in the future to \$176/CY if repair will be needed in the future (assuming that past and future repair rates are identical). If flowfill approaches constructed before 1994 were not considered in the cost-effectiveness analysis, the unit cost of the flowfill over the entire design life would drop to around \$80/CY. This suggests that that the costly flowfill backfill should remain a viable alternative in special applications because it has an outstanding performance.

- ❑ Out of 28 bridge approaches constructed with MSE Class-1 backfill, 4 approaches at two bridge structures failed. Pure construction problems caused the failure of the MSE approaches that could be avoided in the future with better and tighter construction specifications for the backfill and embankment materials. These failures would not be eliminated if flowfill backfill was employed because the primary sources of the settlement problem were the embankment and foundation soils, not the 4-ft thick backfill placed beneath the sleeper slab. However, it is possible that the extent of these failures would be reduced with flowfill because construction problems in MSE backfill, like lack of compaction or construction timing, will not be of concern with flowfill. Generally, MSE backfill is more sensitive to construction problems than flowfill.

□ The use of MSE Class 1 backfill is cost effective ONLY if the rate of repair of MSE approaches will decline significantly in the future. In this case, the unit cost of MSE approaches over their entire service life would be much less than that for flowfill and comparable to approaches constructed with MSE Class B. However, if the past rate of repair of these approaches would continue in the future, the unit cost will much be higher because: 1) the repair costs of the four failed MSE Class-1 Backfill approaches were significant, 2) the limited number of constructed MSE approaches, 3) and the relatively short service period of MSE approaches.

□ The MSE Class B filter material as abutment backfill has the lowest cost. This is because no repair was reported for the MSE Class B approaches and their current performance is adequate. A more scientific evaluation on the performance and cost-effectiveness of the MSE Class B Backfill material should be made after five or 10 years when both number and average service life of MSE Class B approaches have increased.

Based on the above, the study recommends that CDOT continues to use of MSE approaches with both Class B and Class 1 backfills over the next few years and to monitor and document their performance and repair costs. Then, a cost-effective analysis of various abutment backfill materials (flowfill, MSE class-1, MSE Class B) should be performed as described in this study to determine the abutment backfill material that has the lowest cost for an acceptable performance over the entire service life of 40 years.

Table 4.5. Performance of Flowfill and MSE Bridge Approaches.

Type of Abutment Backfill	Flowfill	MSE Class 1 Backfill	MSE Class B Filter Material
Number of bridge approaches (# of bridges)	202 (98)	28 (14)	20 (10)
Rating based on approach slab settlement			
With no or minimal bridge bump problem	183	24	20
With slight to moderate bridge bump problem	13		
With severe Bridge Bump Problem	6	4	
Rating based on inspection records of CDOT Staff Bridge			
Good	182	26	20
Fair	20		
Poor		2	

Table 4.6. Cost-Effectiveness Analysis of Flowfill and MSE Bridge Approaches.

Type of Abutment Backfill	Flowfill	MSE Class 1 Backfill	MSE Class B Filter Material
Number of bridge approaches (# of bridges)	202	28	20
The 2005 Unit Construction Cost of the Approaches per CY, \$	76	37	57.5
Volume of Placed Backfill (CY)	40400	5600	4000
Average Number of Service Years until 2005	7.69	3.99	2
2005 Expended Total Repair Costs (\$)	264500	69500	0
2005 Required Total Repair Costs (\$)	514000	50000	0
2005 Total Repair Costs (\$)	778500	119500	0
2005 Unit Repair Cost (\$) per CY of the Backfill	19.27	21.34	0
2005 Unit Cost (\$) per CY-Lower Limit	95.27	58.34	57.5
2005 Unit Repair Cost over the Service Life of 40 Years Per CY (\$)	100.23	214.16	
Total 2005 Unit Cost (\$) Over the Entire Service Life of 40 years Per CY- upper limit	176.23	251.16	57.5

5. INVESTIGATION OF BRIDGES WITH SEVERE BRIDGE APPROACH SETTLEMENT PROBLEMS

5.1 Objectives

This chapter presents the causes and sources of the current bridge approach settlement problem at the sleeper slab for five bridge structures that experienced significant approach settlement problem (ranked 3, see previous chapter). Evaluations were made to determine if this settlement has more or less ended or had significant settlement potential remaining. It is important to identify the sources, causes, magnitude, and timing of current and future settlements to develop an effective plan for repair and mitigation of the settlement problem.

The investigation described in subsequent sections focused on five bridge structures that were ranked 3 in the previous chapter. Three of these bridges thoroughly investigated in this study are:

1. Salt Creek Bridge along SH 50 (L-18-BD) in Region 2. This structure was constructed with MSE abutment backfill.
2. SH 287 Over Little Thompson River (C-16-DK) in Region 4. This structure was constructed with flowfill abutment backfill.
3. I-70/I-225 Interchange in Region 6. This structure was constructed with flowfill abutment backfill.

And two more structures were previously investigated by CDOT Soil and Foundation Units and they are:

4. Structure E-19-Z on US 36 East of Bennett in Region 1. This structure was constructed with MSE abutment backfill.
5. Structure E-17-PR @ I-76 at 136th Ave in Region 6. This structure was constructed with flowfill abutment backfill.

The investigations performed on these structures are based on the materials presented in Chapter 3.

5.2. Salt Creek (L-18-BD) (MSE Abutment Backfill)

5.2.1 Description of the Bridge Structure

The new Salt Creek Bridge (Structure L-18-BD), located in Pueblo, Colorado, carries SH 50 C over Salt Creek. The sides of the bridge and approaching roadways are supported by MSE walls. The front MSE wall supports the bridge abutment, which extends around a 90-degree curve into a “lower MSE wall” supporting a second tier, “upper MSE wall”. A section through the front MSE and abutment walls and a section through the upper and lower MSE walls are shown, respectively, in Figures 5.1 and 5.2. It is unfortunate that the reinforcements of the lower MSE walls do not extend below the leveling pad of the upper MSE walls (Figure 5.2) for better integration of the two MSE walls (so that the two wall bodies act as one body). This would increase the overall stability of the two MSE structures and alleviate the potential for development of a weak zone or a gap between the two walls. Note that continuous tension cracks were found at the concrete pavement between upper and lower tiered MSE walls. In addition, placement of reinforcement layers in the foundation soil below the leveling pad of the upper MSE wall will strengthen that foundation. *It is recommended that in the future the reinforcements of the lower wall be extended beyond the leveling pad of the upper MSE wall and the length of reinforcements of these walls be increased on a one to one slope as was performed for the front MSE wall (see Figure 5.1). Also, it is recommended that the reinforcements placed in the upper MSE wall be wrapped around as was performed for the reinforcements placed behind the abutment wall.*

5.2.2. Description of the Bridge Bump Problem

The study investigation of the bridge bump problem focused on the SW corner of the Salt Creek Bridge (see Figure C.1), where the problem was thought to be the worst.

Sharon Wilson from CDOT Staff Bridge wrote on December 2, 2003: “At all four abutment corners, there is evidence of settlement of the MSE backfill and the upper tier walls and bridge approach slabs. At the SW corner of Structure L-18-BD, the settlement is far more pronounced and the upper tier wall has displaced laterally immediately behind the abutment. At this location, the

settlement and displacement have become more pronounced than at the time of an earlier visit September 13, 2003.” And wrote on another occasion “Because we do not know if the movement here has stabilized or is continuing, and we do not know entirely the cause of the movement, a permanent repair may be premature. Staff Bridge understands that the Region would like to have the original contractor complete permanent repairs, but we recommend that the drainage be corrected first and the walls surveyed to establish bench-mark measurements for future monitoring. To correct the drainage, the bridge approaches should be repaved and any cracks in the asphalt between the approach slab and the roadway should be sealed with crack sealant.”

Sharon also wrote on November 3, 2003: “Also the settlement appears to be only near the abutments, and is not evident midway between the two bridges. Two possibilities I had considered was potential saturation of the fill near the abutment due to intrusion of water causing loss of bond, and potential collapsing soil in the foundation material. I do not know what the condition of the original structure was and whether there was an indication of collapsible foundation material. There were several weep drains along the wall and they all appeared to be functioning along the north side. On the south side, there is a large drain from inlets that are about midway between the two bridges, but the weep drain closest to the SW abutment of the river bridge did not appear to be working. However, there was evidence of drainage coming through some of the separations between blocks and the open joint in the slope pavement.”

A digital road profiler was used to draw elevation profiles of the transition section from the bridge deck to the approaching roadway (see Abu-Hejleh et. al., 2001 for more on this technique). The measured and design elevation profiles along the shoulder line of the southwest corner of the bridge-roadway zone are shown in Figure 5.3. The construction plans indicate that the final design elevation of the top surface of the pavement in that zone drops at a rate of 0.06 inch/ft in the direction going west to east. Based on the measured and design elevation profiles, the settlement profile along the bridge approach was developed (Figure 5.4). At the sleeper slab, the settlement was estimated at 4.32 inches. Across the bridge, the design slope was 0.02 ft/ft. The measured average slope was 0.029 ft/ft. Assuming that the median did not settle, this suggests a settlement of around 4.5 inches at the sleeper slab by the shoulder line. This is close to the settlement estimated from the longitudinal elevation profile.

5.2.3. Review of the Construction Plans and Geotechnical Report

Review of the construction plans revealed that the new bridge and approaching roadways with side MSE walls replaced an older bridge with side sloped embankments. The new bridge and roadway structures were only extended on the sides. The boundaries of the old and new bridges at the SW corner of the bridge are illustrated in Figure 5.5. A granular fill was used for construction of the front, lower and upper MSE walls as shown in Figures 5.1 and 5.2. Part of this fill was to replace old embankment soil that was removed and additional fill was placed above the original ground level mainly for the lower and upper MSE wall (beneath the sidewalk and part of the shoulder, see Figure 5.5).

5.2.4 Results of the Subsurface Geotechnical Investigation

Two borings were drilled. Boring 1 was located in the approach slab, about 6' from the bridge abutment and 6' from edge of the sidewalk. Boring 2 was located 3.5 ft from the sleeper slab joint toward the roadway and 3.5 ft from edge of the sidewalk. For these borings, Figure 5.6 shows a log of subsurface materials encountered, driving test results in term of N-values collected from the SPT and California Samplers, and locations and types of all collected soil samples. According to Boring 1, the depth of the abutment and embankment fill materials is around 35 ft and the thickness of the foundation soil layer is 35 ft. Rock was encountered at a depth of 70 ft. The log results suggest that the N-values obtained from SPT and the California Sampler are comparable.

5.2.4.1 Backfill and Embankment Materials

Table 5.1 and Figure 5.6 list all the laboratory and field test results on the abutment and embankment fill materials. The granular backfill is described as medium dense in Boring 1 (N-values from 13 to 14), and loose in Boring 2 (around the sleeper slab). The tabulated results suggest that the backfill materials of Boring 1 nearly met the requirements for gradation, compaction, and Atterberg limits (measured PI of 8 is close to the required value of 6) for Class 1 structure backfill. However, the compaction requirements were not met for the backfill placed in Boring 2 (Table 5.1) for a depth that extends up to 20 ft. Both the field and laboratory test results

suggest that the applied compaction for the backfill was not uniform and the backfill of Boring 2 was poorly compacted.

The measured water content for the granular backfill was above the optimum water contents. *This suggests that the drainage measures, employed in the project to prevent surface water from reaching the fill, have failed.* The degree of saturation of the granular backfill was roughly estimated as 70% for the medium dense backfill of Boring 1 and 45% for the loose granular backfill of Boring 2. Based on these results, there is a need to explore the potential future settlement of the loose granular backfill due to increase in the moisture content of the backfill, assuming that the soil moisture content did not increase in the past above the level measured in this study. Two samples from the Class 1 granular backfill material (see Table 5.1) were remolded in the consolidation test cell at loose compaction conditions (relative compaction around 82%) as measured in Boring 2. For the 1st sample, the initial water content was 3.3% (dry of the optimum), and for the other sample the initial water content was 8% (wet of the optimum, close to the measured moisture in Boring 2). These samples were consolidated to a vertical stress of 1 ksf. Then, the samples were inundated to measure the resulting hydrocompression strain over 24 hours (Coduto, 2001). Last, additional stress increments were applied as in the conventional consolidation test procedure. Results of the two tests are shown in *Figure 5.7 and they demonstrate the compression of the samples upon wetting, especially when the fill is placed on the dry side of optimum. Similar results for two well-compacted granular samples are shown in Figure 5.8. The results suggest that compression of a well-compacted class 1 backfill upon wetting remains of concern if the placed moisture content is on the wet side of the optimum.*

For SM-SC granular soils, it is recommended in the literature to use a value for $C_c/(1+e_0)$ of 0.02 for the very loose state and a value of 0.01 for the medium dense granular soils. These consolidation characteristics were assumed in the settlement analyses.

Table 5.1. Laboratory and Field Test Results for the Fill Material of the Salt Creek Bridge Approaches

Modified proctor test results for the granular backfill, AASHTO T-180, two tests:										
1. Maximum dry density values 136.3 pcf and 137.7 with average of 137 pcf (required dry density is 95% of 137.7 = 130 pcf).										
2. Optimum moisture contents are 4.9% and 5.6% with average of 5.3%.										
Depth (ft)	N-(bpf)	γ_d (pcf)	w (%)	% gravel	% sand	% Fines	LL (%)	PI (I)	Consistency	Classification & Description
Requirements for Class 1 Backfill used in this Project										
		130		0-30	0-95	5-20	<35	<6		
Boring # 1										
7	19	127	7.4						Medium Dense	
7	19	128	7.1							
17	19		7.2							
17	19		7.1							
27	23	130	7.7							
27	23	131	7.9							
Boring # 2										
4	7	112	7.4						Loose	SC, A-2-4(0)
5	7	115	9.1	13	68	19	23	8		
5	7	116	7.2							
10	7	116	9.4	20	65	15	21	6		

5.2.4.2 Foundation Soils

Table 5.2 and Figure 5.6 list all the laboratory and field test results on the foundation soil. The pockets of granular materials encountered between the compressible clay layers can be described as medium dense silty sand with gravel (SM and A-1-b). Most of the foundation soil layers can be described as medium stiff sandy lean clay (swelling potential is very low). In terms of compressibility, it can be described as “*slightly compressible.*” The initial degree of saturation of the foundation was high (80% to 90%, potential for softening in the future due to water intrusion is low). Water was added at the beginning of the consolidation test. This will take care of any settlement that could occur in the future due to an increase in the soil moisture content. The measured creep index values (0.002 to 0.005) are relatively small.

Before construction of the new Salt Creek Bridge, several test holes were drilled during the subsurface geotechnical investigation. Test hole F-9 was drilled in the approach slab close to the CENTER of the old bridge (west side). A clay layer was encountered in Boring F-9 as in Boring 1

but with much higher SPT N values ranging from 14 to 28 blows per foot compared to values of 6 and 7 obtained in Boring 1 of this study. The clay foundation layer was described in the construction plans as very stiff, but medium stiff clay was encountered in Boring # 1. This significant difference is hard to explain. One possible reason is that the foundation clay layer encountered in Test Hole F-9, placed close to the center of the old bridge, was allowed to consolidate under the fill of the old bridge for more than 40 yrs, and this was not the case for the clay layer of Boring 1 located near the edge of the old bridge. Another reason is that the old SPT data of Boring F-9 were collected during the dry time of the year when the foundation soil may have been stiffer and the GWT was at its deepest elevation. The SPT data of Boring 1 were collected during the wetting season in Colorado (April to June). *Hence, seasonal corrections of the SPT data collected during the dry season should be made based on the expected highest soil moisture contents during the wet season. The study recommendations for location of test holes are:*

- *Shallowest location close to the foundation soil layer (location of lowest consolidation potential).*
- *Locations where the fill height above the original ground level is expected to be the highest.*

5.2.5 Settlement Analysis and Results

The assumptions employed in the settlement analysis are:

- Height of the fill that replaced the embankment material of the old bridge is 25 ft for the upper MSE wall and 15 ft for the lower MSE wall. On top of this fill, it is assumed that an additional 10 ft of fill was placed per unit length of the wall over a width of 25 ft that extends (perpendicular to the wall) from the facing of the lower MSE wall to 9 ft behind the facing of the upper MSE wall (minimal additional fill load was added in the zone around the center of the new bridge). Wall loads are assumed to be applied like in continuous footing foundations.
- The compressible medium stiff clay layer is assumed to extend 35 ft (see the log in Figure 6.6), to have $C_c/(1+e_0)$ of 0.08, coefficient of consolidation C_v (ft²/day) of 0.26 ft²/day, and a creep compression index, C_α of 0.004.

Table 5.2. Laboratory and Field Test Results for the Foundation Soil of the Salt Creek Bridge Approaches.

Depth (ft)	N- (bpf)	γ_d (pcf)	w (%)	% gravel	% sand	% fines	LL (%)	PI (I)	Consistency	Classification & Description
37	6	106	17.3						Medium Stiff	Sandy lean clay, CL, A-4-2 to A-4-3
37	6	105	17.4	0	43	57	23	15		
38.5	6	103	18.1	0	32	68	25	8		
56.5	6	105	20.1	15	21	64	32	20		Sandy lean clay with gravel to lean clay, CL, A-6 (10)- (20)
62	7					90	37	14		
Consolidation Test Results										
Water was added at the start of the test to fully saturate the samples, swelling is negligible										
Test 1 for Specimen collected from Depth of 38.5 ft (see above description)										
Saturation level increased from 84% to 100%, specific gravity is assumed 2.7, $e_o = 0.634$										
C_c	$C_c / (1+e_o)$	Load (ksf):	0.4	0.8	1.6	3.2	6.4	12.8		
0.09	0.06	C_v (ft ² /day):	0.06	0.08	0.21	0.29	0.31	0.71		
		C_α	0.002	0.002	0.0003	0.002	0.002	0.001		
Test 2 for Specimen collected from Depth of 56.5 ft (see above description)										
Saturation level increased from 91% to 100%, specific gravity is assumed 2.7, $e_o = 0.599$										
C_c	$C_c / (1+e_o)$	Load (ksf):	1	2	4	8	16			
0.13	0.08	C_v (ft ² /day):	0.15	0.26	0.12	0.29	0.21			
		C_α	0.003		0.005	0.005	0.004			

- A $C_c/1+e_o$ of 0.02 was assumed for the loose granular backfill and 0.01 for the medium dense granular fill material. It is assumed in this analysis that all the soil layers are normally consolidated, except the upper 4 ft assumed to be overconsolidated with a preconsolidation pressure of 250 psf for the loose fill material and 500 psf for the medium dense fill soil layers.

Four causes of settlement were investigated:

- The time dependent consolidation settlement of the clayey foundation layer under the influence of newly added 10 ft of fill load.

Results: settlement of the foundation clay layer below the lower MSE walls was calculated to be 2.4", settlement of the foundation clay layer below the upper MSE walls was calculated to be 1.4", and settlement of the foundation clay layer below the center of the new bridge was negligible because very small fill load was added.

- Collapse of the granular fill upon wetting (or increase of its moisture content after construction was completed, see Figures 5.7 and 5.8). An estimate of the generated and future collapsible type of settlements requires information on the maximum fill moisture contents before and after construction was completed and the maximum future moisture content. Assume an initial fill moisture content of 5.3% (optimum) and a maximum fill moisture content of 8% (Table 5.2, Boring 2). Based on the results of Figure 5.7, the wetting settlement that occurred in the past in the 20 ft loose granular backfill (Boring 2) is estimated at 4.8" (occurred during and after construction) and the future wetting settlement of that layer is estimated at 1.2". Based on the results of Figure 5.8, the wetting settlement that occurred in the past in the 25 ft medium dense granular backfill (Boring 1) is estimated at 1.5" (occurred during and after construction) and the future wetting settlement of that layer is expected to be minimal.

- The self-weight consolidation settlement of the 35 ft of fill layer (upper MSE wall only, assumed to be fully saturated). This settlement occurs within the fill materials after compaction is completed due to the weight of the overlying soil layers. Though granular soils typically experience their self-weight consolidation settlement during or shortly after construction, some of these settlements may be delayed until the thawing and wetting season is over, that is until the soil is subjected to its highest water content so any softening responses will surface up. Therefore, within a year of construction completion, after the soil is subjected to the cycle of thawing/wetting season, it is expected that most of the self-weight consolidation settlement in the granular fill would occur.

Results: Total settlement of 2.4" around Boring 1 (close to abutment wall, medium dense fill layer), and 5.6" around Boring 2 (near to the sleeper slab, 20 ft loose fill and 15 ft medium dense fill).

Note: It is often reported that the wall's granular backfill will consolidate during and after construction and this settlement is related to the depth of the fill, the degree of compaction, the moisture content, and type of fill. Settlement for properly compacted backfill material is roughly estimated to be 1% of the total fill height ($0.01 \times 35 = 0.35 \text{ ft} = 4.2''$). *This approximation seems to be on the conservative side (estimated here 2.4'')*.

- Settlement of the sleeper slab placed on the loose granular fill due to the dead and live loads carried by the approach slab. This load is assumed to generate a bearing pressure of 900 psf under the 4ft wide sleeper slab.

Results: Total settlement of 1'', 0.9'' in the fill and embankment granular soil layers, and 0.1'' in the foundation clay layer. If the granular fill was compacted well, the settlement will drop to 0.5'' (reduce by 50%).

- Creep or long-term time dependent settlement under constant load. In the clay layer, this settlement would be less than 0.5'' over 10 years after construction was completed.

5.2.6 Causes of the Approach Settlement Problem

The approach settlement problem at the Salt Creek Bridge Structure appears to have been caused by three mechanisms

- Settlements of the foundation clay layer due to new fill placed above the original ground level in the lower MSE wall and upper MSE wall. This settlement occurred along the sides of the structure: lower MSE wall and within 10 ft behind the facing of the upper MSE wall. At a distance of about 10 ft from the facing of the upper MSE wall, the added fill load was very small (no observed settlement). *The non uniformity of the applied fill loads resulted in the observed differential settlements pattern across the approaches:* the approach settlements are only concentrated behind the abutment and upper MSE walls, and is not evident close to the median of the bridge. Also, the settlement of the foundation layer below the lower MSE wall (2.4'') was larger than the settlement of the foundation layer below the upper MSE wall (1.4'')

because the lower MSE wall is closer to the compressible foundation layer (smaller distance for the fill loads of the lower MSE wall to dissipate with depth). The differential settlement between the lower and upper MSE walls could explain the gap or tensile cracks developed between the upper and lower MSE walls and between the lower MSE wall and the abutment. The presence of tensile cracks in that zone could also be an evidence of lateral displacement of the lower MSE wall.

- ❑ Settlement of the loose granular fill material placed below the sleeper slab to a depth of 20 ft. This granular fill was poorly compacted, possibly because it was placed during the winter season. Most likely this problem is concentrated within 30 ft from the sleeper slab toward the roadway (based on Figure 5.4). The fill between the sleeper slab and the abutment wall appears to have been well compacted.
- ❑ Failure of the drainage measures placed to keep the surface water from reaching the fill layer and possibly the foundation layer. This softens the soil layers.

5.2.7 Sources, Magnitude, and Timing of the Approach Settlement Problem

Field observations and measurements suggest settlement problems was severe in two zones

1) The zone located behind both the upper MSE wall and the abutment wall. The settlement in this zone was noticed because the end of the approach slab is supported by the abutment wall that did not settle, so a gap developed between the approach slab and the settling soil beneath it. This is also true for the observed settlement of the lower MSE wall relative to the abutment wall. Most likely, this kind of settlement occurred to the upper and lower MSE walls located on the roadway side of the sleeper slab but was not noticed because the roadway settled with the soil beneath it. The profiling data presented in Figure 5.4 suggest so. In that zone, the placed backfill was well compacted so most likely the settlement problem occurred due only to the compressible foundation soil layer. Some of the settlement in that zone could also be attributed to the lateral displacement of the facing blocks discussed later.

Sources and Magnitude of the Settlement. The consolidation settlement analysis suggests total settlement of 1.4” in the foundation clay layer and wetting settlement up to 1.5” in the well-compacted granular fill layer. Creep and self-weight consolidation settlements are discussed next.

Timing of the Settlement Problem. The structure has been in service for two years since construction was completed.

It is estimated that 80% of the consolidation settlement of the clay layer has occurred over the last two years (1.1”) and 0.3” is expected to occur in the next two years. In addition, creep settlement of the foundation layer is estimated to be an additional 0.5” over a long time period of 10 years. *Because the structure has been in service for more than two years, future settlements due to wetting and self-weight consolidation of the well-compacted granular soils are expected to be minimal.*

2) The zone below the sleeper slab. Causes of settlement in this zone are the presence of loose fill soil, the dead load and live loads carried by the approach slab and supported by the sleeper slab, and the new added fill behind the facing of the upper MSE wall. All these factors make the zone under the sleeper slab and behind the upper MSE wall the most critical zone as noticed in the field observations.

Sources and Magnitude of the Settlement Problem. The consolidation settlement analysis suggests a settlement of 1.5” in the foundation clay layer and more than 7” of settlement in the poorly compacted granular fill layer. Creep settlements are discussed next.

Timing of the Settlement Problem. Most of the consolidation settlements of the clay layer (1.5”) will occur after placement of the sleeper slab. Around 50% of this settlement should have been completed within one year after placement of the sleeper slab and 80% (1.2”) within two years. The settlement-time curve of the sleeper slab due to consolidation of the foundation clay layer is presented in Figure 5.9 and it is clear that the long-term settlement of the foundation clay layer after two years (the structure has been in service for two years) is small.

Of the 7” settlement in the fill, 1” will occur after placement of the sleeper slab due to the live and dead loads carried by the approach slab and transferred to the sleeper slab. The remaining 6” are due to wetting of the granular soil with up to 1.2” settlement is expected in the future. Because the structure has been in service for more than two years, only minor self-weight consolidation settlement in the granular fill layer should be expected.

Creep soil settlement in the foundation clay layer up to 0.5” is expected to occur within 10 years after construction is completed. *Continued settlement in the loose granular backfill could remain of concern in the future because loose granular soil has the potential to creep under constant loads and the chances are even higher when it is subjected to continuous dynamic loading due to vibration and pounding of the bumpy sleeper slab due to truck traffic.*

3) Lateral displacements of the facing blocks of the MSE walls (see Figure C.1, facing settlement in the upper MSE wall and some facing lateral displacement in the lower MSE wall). Lateral displacements of the facing blocks can occur when the applied lateral loads on the facing blocks exceed the in service block-to-block connection capacity of the blocks, so a lateral displacement problem would occur due to increased lateral earth loads on the blocks and reduced block-to-block capacity. The weight of the rail coping was not felt in this zone beneath the approach slab. This reduced the block-to-block connection capacity and increased the chances for lateral displacement of blocks in this zone. The weight of the rail coping was felt by the blocks of the upper MSE from the sleeper slab toward the roadway where no bulging problem was noticed.

The facing distress problem seems to be severe for the facing blocks located below the sleeper slab along the high areas of the upper and lower MSE walls. The facing problem is aggravated in this zone by the surcharge load applied on the sleeper slab that induces high vertical and lateral loads on the facing blocks. The influence of these high surcharge loads is magnified by the low compaction level of the granular fill in that zone which will increase the lateral earth pressures on the facing. Settlement of the fill relative to the wall facing may have resulted in the transfer of some of the vertical earth loads to the facing. Finally, the block-to-block connection capacity is

relatively low in the upper zones of the lower and upper MSE walls because part of that capacity is derived from the weight of the overlying blocks, which is relatively smaller in the upper zones.

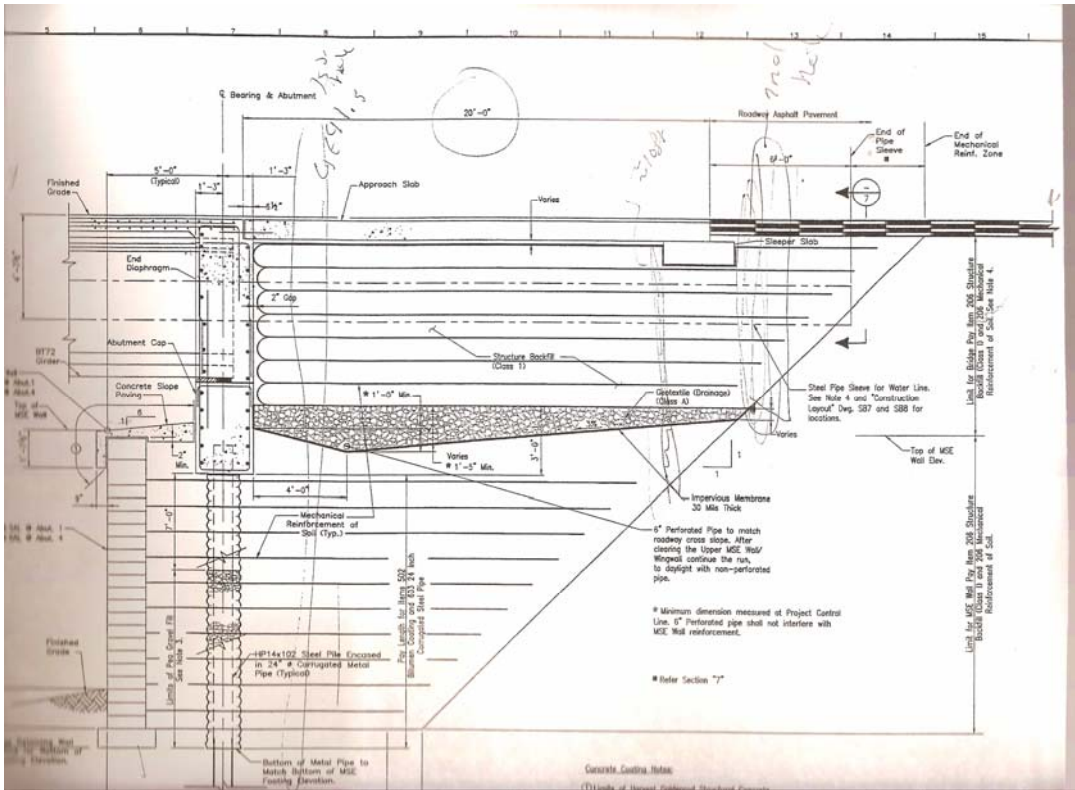

Figure 5.1. A Section along the Front MSE Wall of the Salt Creek Bridge.

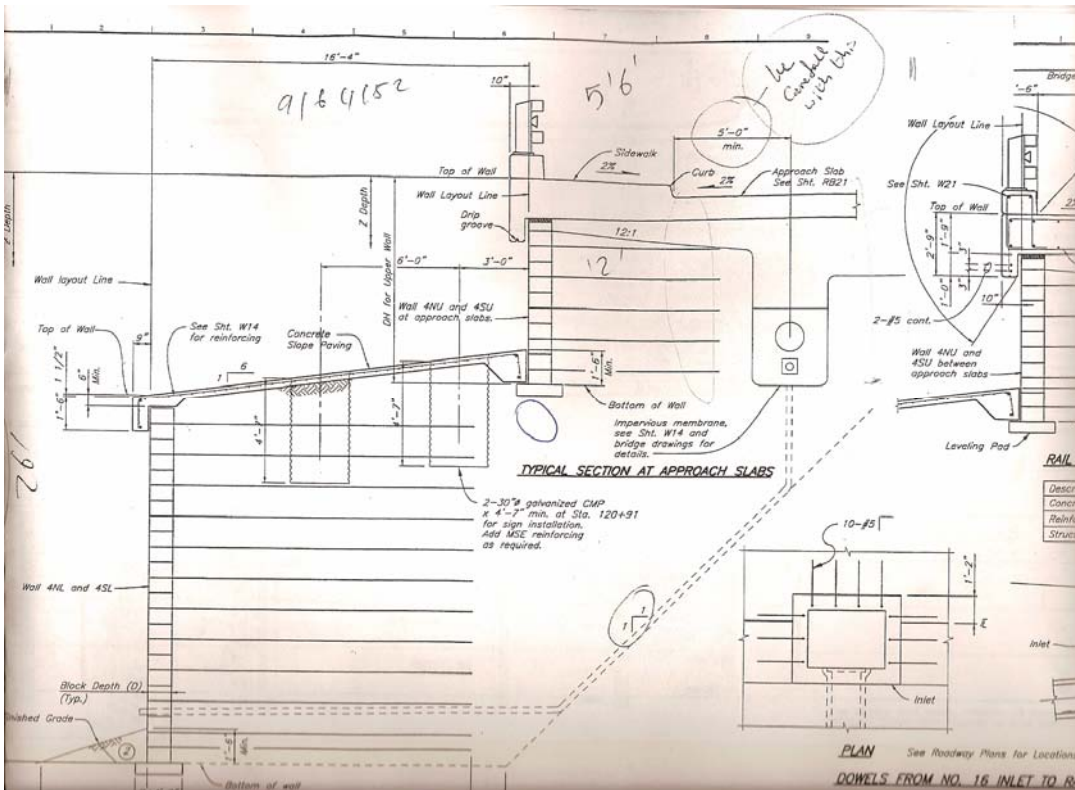

Figure 5.2. A Section along the Upper and Lower MSE Walls of the Salt Creek Bridge.

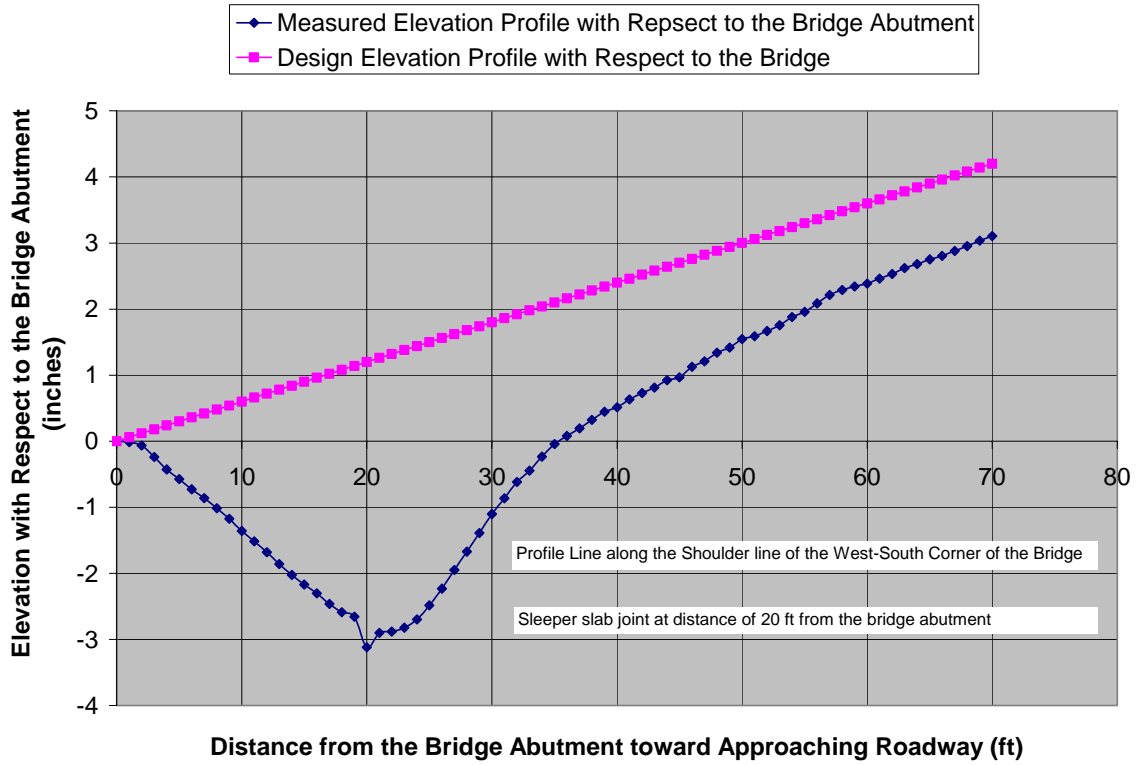

Figure 5.3. An Elevation Profile of the Bridge Approach along the Shoulder Line of the SW Corner of the Salt Creek Bridge Approaches.

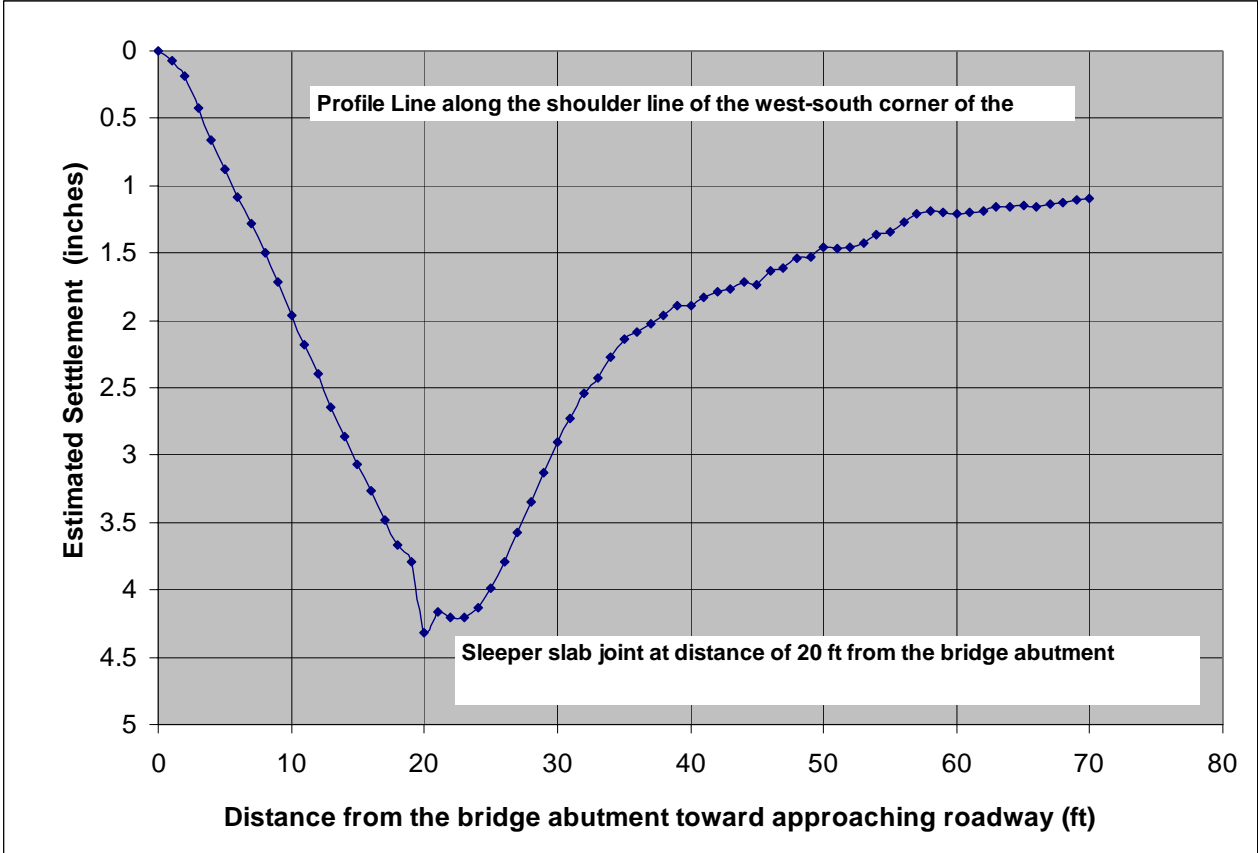

Figure 5.4. A Settlement Profile of the Bridge Approach along the Shoulder Line of the SW Corner of the Salt Creek Bridge Approaches.

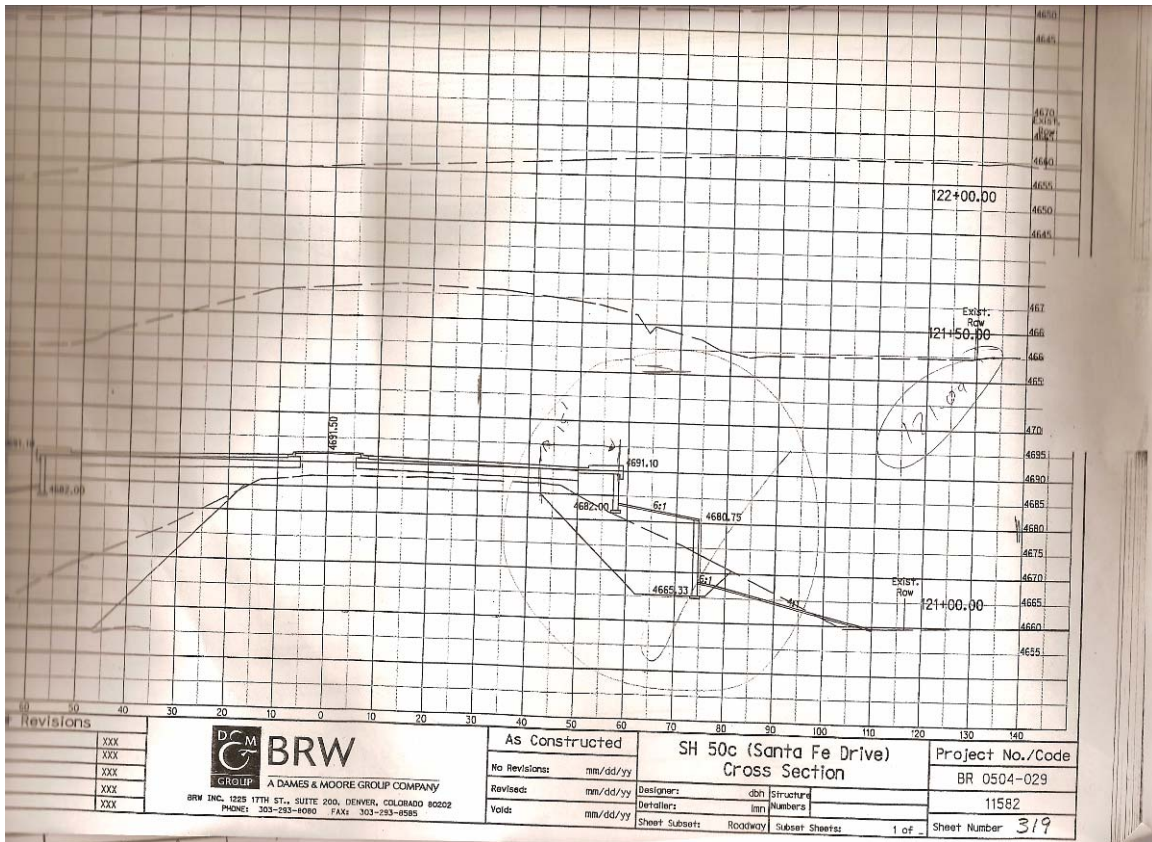
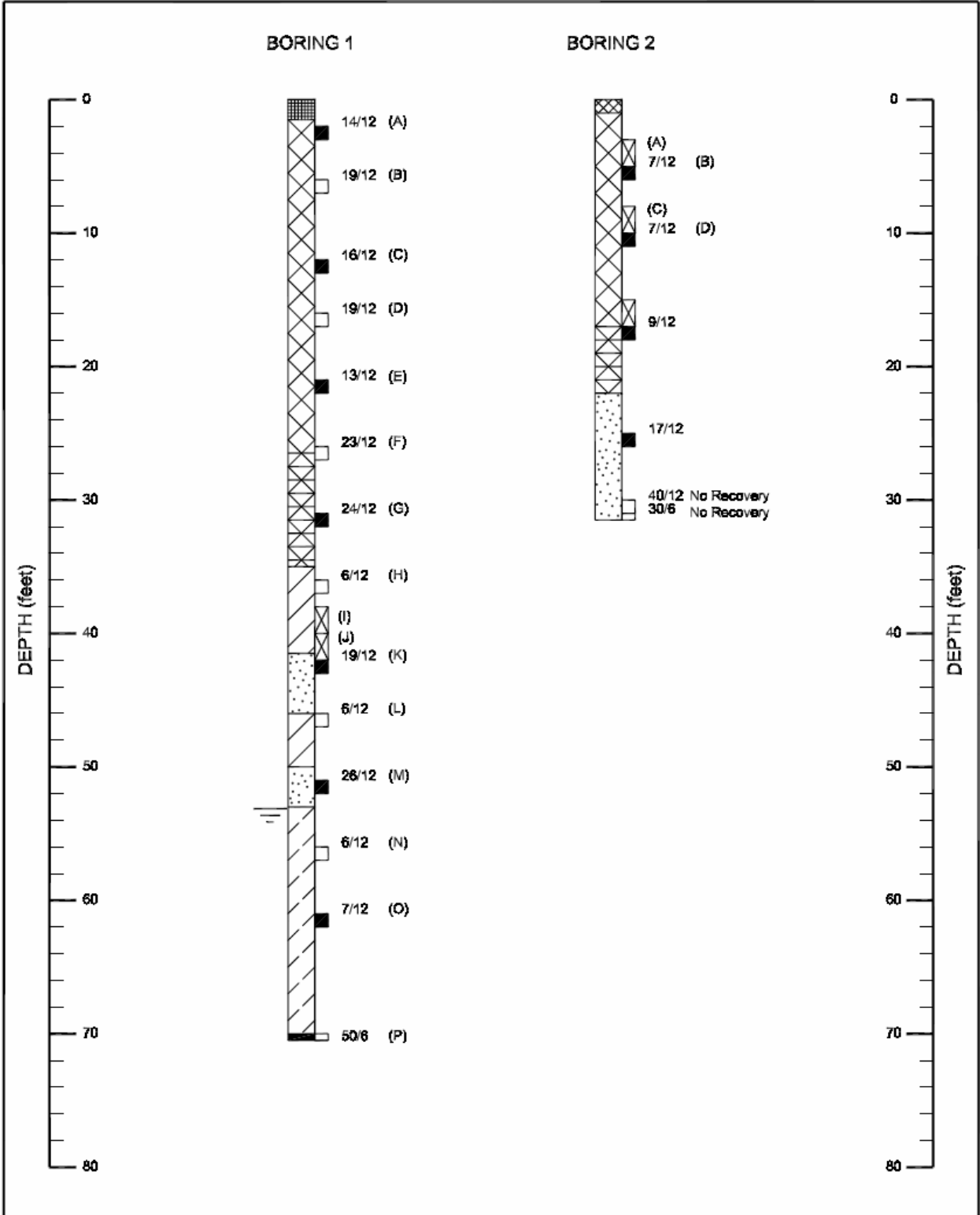













Figure 5.5. Elevation Profiles across the SW Corners of the Old (dashed line) and New (solid line) Bridge Approaches of the Salt Creek Bridge.



LEGEND

-  CONCRETE PAVEMENT
-  ASPHALT PAVEMENT
-  FILL - SAND, gravelly, silty to clayey, loose to medium dense, moist to wet, brown. Material is believed to be CDOT Class 1 Structural Fill placed during bridge reconstruction project in 2000.
-  FILL - CLAY, sandy to very sandy, silty, stiff to very stiff, moist, dark brown. Material is believed to be old fill placed during the original bridge construction decades ago.
-  SAND, gravelly to very gravelly, slightly silty to silty, medium dense, moist to wet, brown.
-  SILT, sandy, trace clays, loose, very moist, brown.
-  CLAY, silty to very silty, medium stiff, wet, brown.
-  CLAYSTONE BEDROCK, very hard.

- (A) Denotes sample identification.
- $14/12$ Drive sample blow count, Indicates that 14 blows of a 140-pound hammer falling 30 inches were required to drive the California or SPT sampler 12 inches.
-  Indicates drive sample, 2-inch I.D. California liner sample.
-  Indicates drive sample, Standard Penetration Test, 1 $\frac{3}{8}$ -inch I.D. split spoon sample.
-  Indicates shelby tube sample.
-  Indicates measured ground water level.

NOTES

1. Borings were drilled and logged by CDOT on May 4, 2004 with a truck mounted CME-75 equipped with continuous flight augers.
2. The lines between strata represent approximate boundaries between material types. Transitions between materials may actually be gradual.

Figure 5.6. Boring Logs for the Salt Creek Bridge Approaches

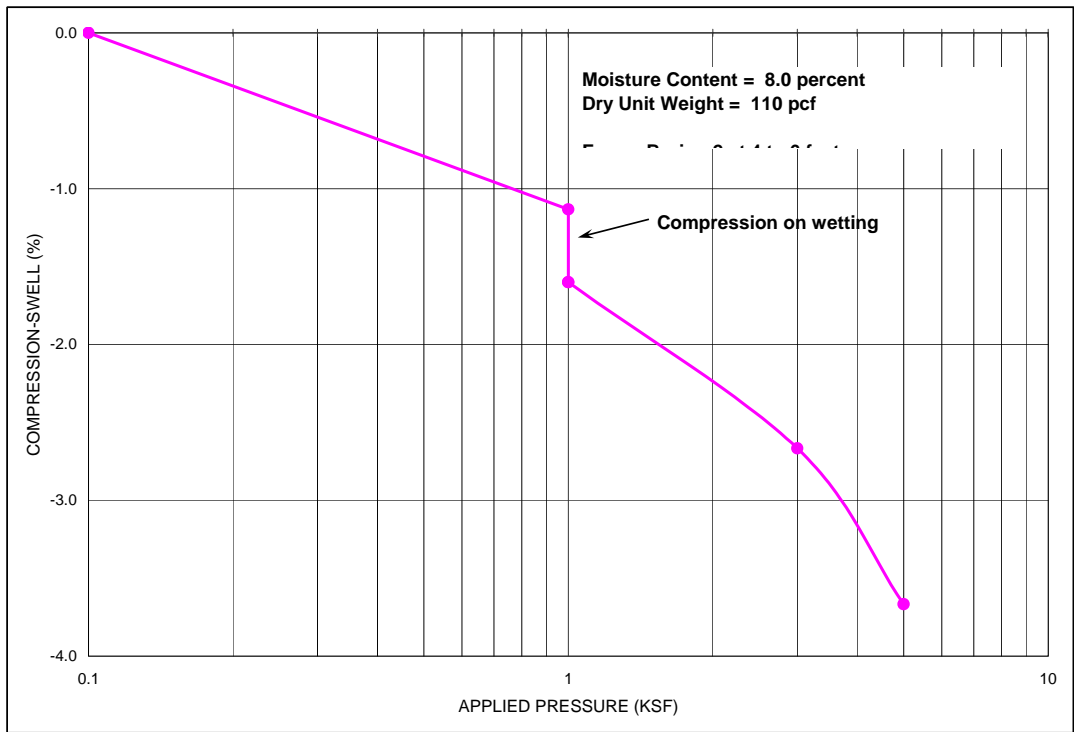
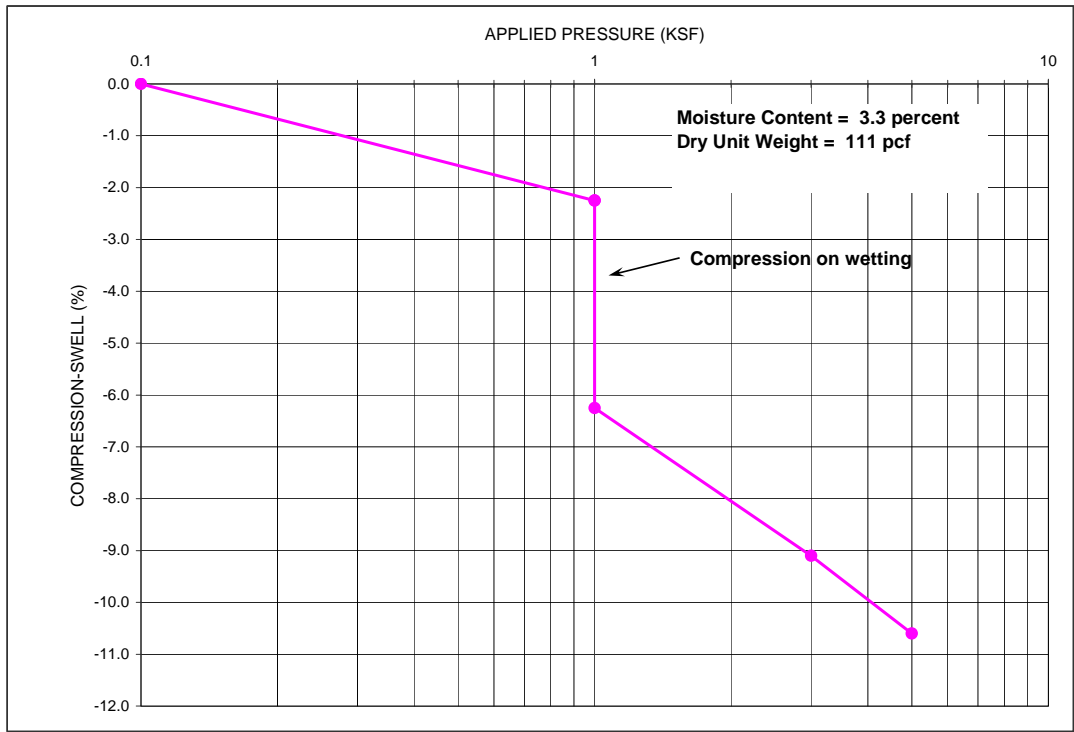

Figure 5.7. Influence of Wetting on a Remolded Soil Sample of Loosely Compacted Class 1 Backfill (Salt Creek Bridge Approaches).

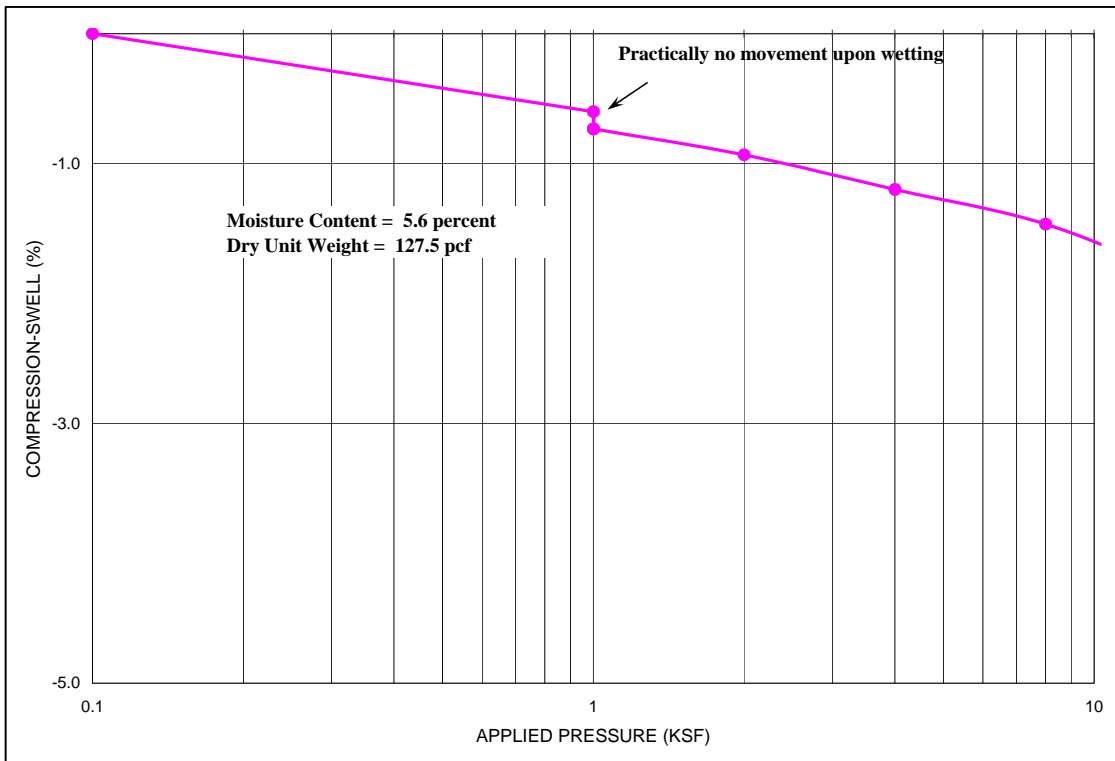
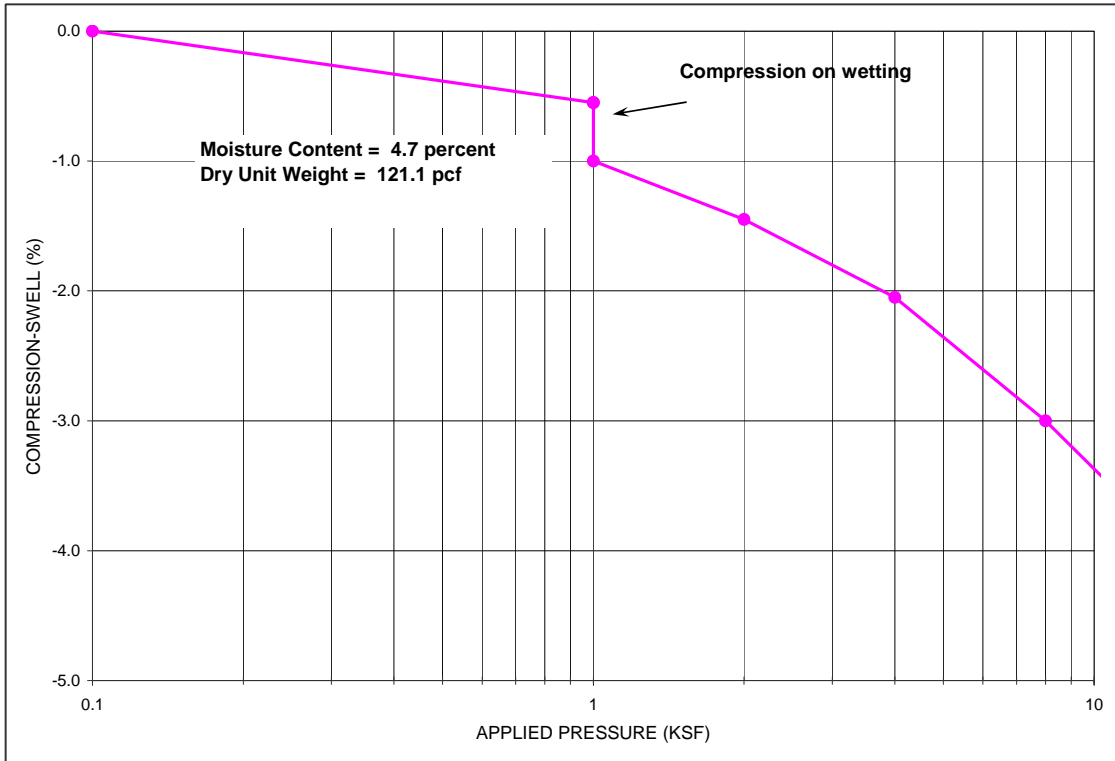

Figure 5.8. Influence of Wetting on a Remolded Soil Sample of Well-Compacted Class 1 Backfill (Salt Creek Bridge Approaches).

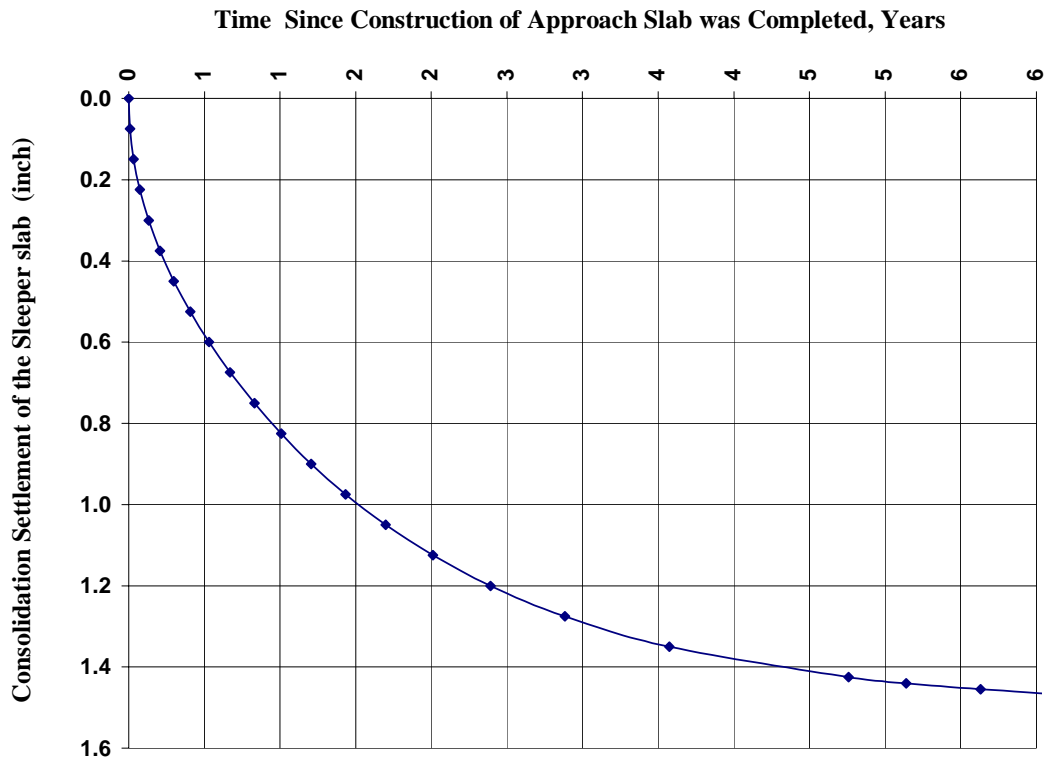

Figure 5.9. Predicted Settlements of the Sleeper Slab Due to Consolidation of the Foundation Clay Layer (Salt Creek Bridge Approaches).

5.3 I-70/I-225 Interchange (Flowfill Abutment Backfill)

5.3.1 Overview of the Problem and Construction Plans

Construction for the ramp that connects I-70 WB to SB I-225 was completed in 1994. The 34 ft wide ramp has two lanes (24') with two shoulders (each 6' wide). Immediately after construction was completed, bridge bump problems were noticed along the roadway approaches, especially on the eastern side of the interchange (*the focus of this study*) as seen in Figures C.2 to C.5. Review of the construction plans revealed that the fill was *higher for the eastern side of the interchange than for the western side and this could explain why the approach settlement problem was more severe along the eastern side of the interchange*. Relative settlement up to 6" was noticed between the roadway and the bridge concrete rail on the northeastern side of the bridge as seen in Figure C.5. No repair was applied except for a thin layer of asphalt placed east of the expansion joint (see Figure C.2).

Review of the construction plans revealed that that the tall abutment and wing walls (~ 30 ft) are supported by one continuous spread footing foundation that is supported by two rows of caissons as shown in Figure 5.10. Flowfill was placed behind the abutment wall as shown in Figure 5.10. Past the wing wall, a 60 ft long cast in place (CIP) cantilever wall (~ 20 ft high) was constructed that is supported through spread footing foundation by end-bearing H-piles (Figure 5.11). The plans required the placement of compacted Class 2 Backfill material behind the wall as shown in Figure 5.11. The base of the cantilever wall extends about 8 ft from the back facing of the wall. From the ends of the CIP cantilever walls, MSE walls were constructed without the support of driven piles. It was required in the construction plans to place the spread footing foundations for all CIP and MSE walls on a 10 ft (minimum) layer of compacted Class 2 structural backfill. A drainage layer of permeable base course material was placed behind the stem of the wall. A 4" inch perforated PVC pipe was placed along the wall at the bottom of this drainage layer (depth of around 17 ft). Along the wall, non-perforated 4" drain pipes were placed 20 ft apart to carry the water from the perforated pipes to daylight (to top of the finished ground grade in front of the wall). Note that the original ground level was raised from a depth of 33 ft below top of the wall to a depth of 18 ft. The construction plans also indicate that the roadway approaches near the eastern

abutment are located along a vertical curve with a design vertical slope of around 0.04 and along a horizontal curve with a cross-sectional slope of 0.08 (superlevated where the north side is higher than the southern side by $34 \times 0.08 = 2.72$ ft).

5.3.2. Results of Surface Inspection

The roadway approaches east of the east abutment (Abutment 9) were examined. No signs of bulging to the side walls was noticed. The bridge concrete rail is connected to the wall, not the roadway as in CDOT current design details. This allowed for a joint between the wall/rail and the roadway which facilitates the passage of water into the soil of the roadway approaches. It was noticed that this joint is open and wide on the north side of the approach roadway (high side) and seems to be closed on the south side (lower side). A digital road profiler was used to draw elevation profiles of the transition section from the bridge deck to the roadway approaches. The measured and design elevation profiles along a line located 2 ft north of the centerline are shown in Figure 5.12.

The observations for different segments of the roadway approaches, starting from Abutment 9 **going east** are:

1. From the bridge expansion joint to the sleeper slab joint (17 ft). The longitudinal and cross-slope are smooth and consistent with the grades for the nearby bridge side as can be seen in Figures C.4 and 5.12. This could be attributed to the presence of a very deep flowfill (very stiff) layer beneath the approach slab.
2. The sleeper slab expansion joint. At the center of the roadway, the eastern side of the expansion device (armored steel plate) settled 1" relative to the western side. The settlement of the roadway relative to the bridge rail at the expansion joint is 1". The expansion joint is in bad condition and should be replaced in the future.

It seems that the approach settlement problems begins at the eastern side of the expansion joint and worsen as you go east.

3. Within 7 ft east of the sleeper slab expansion joint. Significant drop of almost 2” to 3” was noticed in that zone (Figures C.2 to C.4 and 5.12). *This is where the bridge bump is most severe and felt by the drivers. Driving the roadway before and after this zone is tolerable. This is where a thin layer of asphalt was added.*

4. The zone from 7 ft to 37 ft east of the sleeper slab expansion joint. In that zone, the settlement increased gradually from approximately 2.5” to 5.5” (see Figure 5.12). Although this change in settlement causes discomfort to the drivers, most likely it is tolerable. It seems the roadway edge next to the northern bridge rail settled more than the roadway edge next to the southern bridge rail by 2” to 3”, although the flow line for water is located along the southern side. *It seems also that the centerline of the roadway settled more than the edge of the roadway.* This resulted in a deflected cross-section for the roadway as seen in Illustration “a” below not super elevated with a slope of 0.08 as required in the construction plans (see Illustration “b” below).

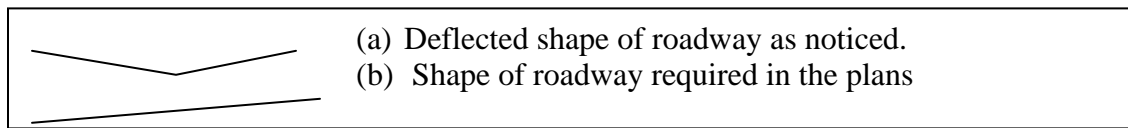

Note: settlement of the roadway relative to the CIP wall (which is supported by deep foundations) is indicative of the settlement of the soil layer (almost 20 ft high) existing between the roadway and base of the CIP wall. But outside the CIP wall base, the soil rests on the original ground layer. Therefore, settlement of the centerline of the roadway resulted from settlement of the fill layer (31 ft) and original ground. This could be the reason for the sinking of the soil at the middle of the approach roadway relative to the sides of the roadway.

5. The zone from 37 ft to 65 ft east of the sleeper slab expansion joint. The observed settlement of the north side of the roadway relative to the bridge rail barrier remained constant at around 6”. At a distance of 43 ft east from the sleeper slab joint, the CIP wall ended and the MSE wall started.

6. The zone from 65 ft to 120 ft east of the expansion joint. The observed settlement of the north side of the roadway relative to the bridge rail barrier reduced gradually in this zone from around 6" at 65' to zero at 120'.

Most likely, there was settlement of the roadway in this zone and east of that zone that is not noticed in this investigation because the roadway settled with the soil beneath it.

5.3.3 Results of the Subsurface Geotechnical Investigation

Two borings were drilled along the eastern roadway approaches 9 ft from the northern side (north eastern corner of the I-70/I-225 interchange). Both holes were advanced, respectively, 6 ft and 35 ft east from the sleeper slab expansion joint. For these two borings, Figure 5.13 shows a log of subsurface materials encountered, driving resistance results in term of N-values collected from the SPT and California Sampler, and locations and types of all collected samples.

Subsurface materials encountered in the two borings generally consists of 0 to 3.5 feet of flowfill underlain by embankment fill material to a depth of 31 ft (26 ft in Boring 2), underlain by native materials. The flowfill is medium dense gravelly sand material. The native material is loose to medium dense silty sand to clayey sand. The GWT was not encountered in this investigation and according to the construction plans is located at a depth of 65 ft.

The source of any current or future approach settlement is the *embankment soil layer* which is the focus of this investigation. Table 5.3 and Figure 5.12 list all the laboratory and field test results, and construction requirements for the embankment. According to the construction plans, it was required that the embankment meet the requirements for Class 2 Structural Backfill (see Figure 5.11). The embankment fill is composed of loose medium dense silty to clayey sand (Embankment Layer 1) underlain by very soft to medium stiff sandy lean clay (Embankment Layer 2).

Measurements of low dry density values and N- values in the embankment indicate that the construction compaction requirements for the embankment fill were not met (see Table 5.3), especially for the clayey layer (Embankment layer 2) that was poorly compacted. The measured

water content (up to 22.1 %) for Embankment layer 2 was way above the optimum (saturation is around 75%) suggesting that the surface and subsurface drainage measures failed to keep water away from this layer. Driving resistance of zero was encountered at a depth between 17 ft and 19.5 ft in Boring 1 (Embankment Layer 2) suggesting the presence of very soft-like slurry- soil layer at that depth. At that depth, the perforated and non-perforated drainage pipes were placed and any drainage problem at that depth will affect the surrounding soil. It is unlikely that Embankment Layer 2 was placed during construction as soft as was measured herein because such a soft layer would not be able to carry the construction equipment. *Most likely, surface water seeped through the relatively permeable overlying top granular soil layer and from the bottom of the drainage layer placed behind the facing of the CIP wall, to Embankment Layer 2 and softened it.*

Table 5.3 also lists the consolidation test results for the two embankment soil layers. The initial degree of saturation was 65% for the 1st embankment layer and 75% for the 2nd embankment layer. Water was added at the beginning of the consolidation test to account for any settlement that could occur in the future due to increase of moisture content. A slight amount of swell was observed that is very minor and insignificant, especially considering the light load at inundation. In terms of compressibility, Embankment layer 1 is described as “*slightly compressible*” and Embankment layer 2 is described as “*slightly to moderately compressible.*”

5.3.4 Settlement Analysis and Results

The settlement analysis focused on the settlement below the sleeper slab using the soil profile obtained from Boring 1. For the consolidation settlement analysis, a $C_c/(1+e_0)$ of 0.01 was assumed for the 3.5 ft flowfill, 0.066 for the 12.5 ft Embankment Layer 1 and 0.11 for the 15 ft thick Embankment Layer 2. The coefficient of consolidation of the two embankment layers was taken as 0.33 ft²/day and the length of the longest drainage path was taken as 7 ft. It is assumed that the construction time for Embankment layer 1 and the approach slab is 1 month.

Table 5.3. Laboratory and Field Test Results for the Embankment Fill of the I-70/I-225 Interchange Approaches.

Depth (ft)	N- (bpf)	γ_d (pcf)	W (%)	% gravel	% sand	% Fines	LL (%)	PI (I)	Consistency	Classification & Description
Embankment Layer 1:										
Proctor test results per AASHTO T-99, Maximum dry density values 117.3 pcf with optimum moisture content of 12.8%. Classification results are listed below at depth of 8 ft.										
Consolidation test result: $C_c = 0.107$ and $C_c/(1+e_o) = 0.066$.										
Requirements for Embankment Layer 1										
		> 111.4	>10.8							
Boring # 1										
5.5	11	106.4	14.5	0	68	32	23	6	Loose to medium dense	Silty, clayey sand, A-2- 4(0)
8	14			2	74	24	32	21		Clayey sand, A-2-6 (1)
11.5	20						23	10		Clayey sand
Embankment Layer 2:										
Proctor test results per AASHTO T-99: Maximum dry density values 114.8 pcf with optimum moisture content of 13.5 %. Classification results are listed below at depth of 23 ft, Boring 2.										
Consolidation Test Results: C_c of 0.186, $e_o = 0.642$, $C_c/(1+e_o) = 0.113$, C_v of 0.34 ft ² /day, and $C_\alpha = 0.002$, and $\sigma'_c = 2.1$ ksf.										
Requirements for Embankment Layer 2										
		> 109.6	> 11.5							
Boring 1										
16.5	3	103.7	13.6	0	45	55			Very soft to medium stiff	Sandy lean clay, A-6-6
18	0						29	18		Lean clay w/sand A-6 (17)
21		106.9	18.7	0	21	79	38	24		
23	11	104.5	19	0	26	74	39	26		
Boring 2										
20	8		17.2	0	26	74	40	25	Very soft to medium stiff	Lean clay with sand, A-6 (10)
23	10			1	43	56	36	26		Sandy lean clay A-6(10)

The sources of settlement of the sleeper slab after construction was completed (see Figure 5.14 for the time progress results) are:

- The time dependent consolidation settlement of Embankment Layer 2 due to the load of Embankment layer 1.

Results: settlements of 3.4". Most of this settlement will occur within 6 months after construction is completed.

- The time dependent consolidation settlement of the two embankment layers due to the dead and live loads carried by the approach slab and transferred to the sleeper slab.

Results: Total settlement of 1.54". Most of this settlement will occur within 6 months after construction is completed.

Note: since the embankment layers were not fully saturated as assumed in the settlement analysis, it is possible some of the settlements predicted above will be delayed and show up later when the soil is fully saturated. Since the bridge has been in service for more than 10 years, it is expected that the soil was subjected to its worst wetting conditions, and no future consolidation settlement should occur.

- Creep or long-term time dependent settlement under constant load. This settlement would be less than 0.5" over 10 years since construction was completed. This settlement can be ignored after that.

5.3.5 Concluding Remarks and Recommendations

I. *Settlement at the I-70/I-225 interchange appears to have been caused by poorly compacted Class 2 Structural Backfill that was not placed as required per CDOT construction specifications. Natural dry unit weights measured on California liner and Shelby tube samples extracted from this embankment material indicated variable degrees of compaction ranging from approximately 82% to 94% (95% required) of the maximum standard Proctor density.*

II. *Settlement analysis concluded that most of the consolidation settlement (around 5") of the sleeper slab should be completed within one year after construction was completed, by 1995 or*

1996 at the most. *The settlement of the sleeper slab is controlled by the embankment materials, not the abutment fill.*

III. The presence of a very soft (almost like slurry) clayey soil layer with high water content is noticed at a depth of 17 to 23 ft from top of the wall. It is unlikely that this layer was placed in this form during construction because such a soft layer would not be able to carry the construction equipment. At a depth of approximately 16 ft, perforated and non-perforated drainage pipes were placed behind the wall facing and any failure of these pipes would affect the surrounding soil. *Most likely, surface water seeped through the relatively permeable top embankment layer and away from any clogged drainage pipes to this clayey soil layer (depth of 17 ft) and softened its upper zone. A field visit in February 2005 indicated that many of the wall's drainage pipes are clogged.* It is suspected that any major approach settlement after 1996 occurred because of the presence of this very soft clayey soil layer with high water content. *The existence and growth of this very soft clayey soil layer could still lead to approach settlement problems in the future.* Any future repair measures should include measures to drain out the water accumulated at the top of this layer. *This repair work can be performed from the ground level in front of the wall located at approximately 18 ft below the top of the wall. The roadway surface can be smoothed by using any simple surface treatment method described before (asphalt overlay or raising the slab). There is no need to stabilize the soil layer located directly beneath the pavement.*

IV. Settlement of the I-70/I-225 roadway approaches within 65 ft east from the east abutment was very noticeable because of the

- Longitudinal sharp variations in the stiffness of the foundation systems that support the walls and fill materials. The spread footing foundations that carry the very high abutment walls, wing walls (~ 5 ft long), and CIP walls (extends 60 ft from the wing walls) are all supported by very stiff deep foundation systems that allow for very small settlement of the facing of these walls. This resulted in the creation of significant differential settlement up to 6" between the edge of the roadway and the CIP wall. MSE side walls extend from the CIP walls with no support from deep foundations. Most likely, large settlement of the MSE

roadway approaches occurred but was not noticed because the roadway settled with the soil beneath it.

- Longitudinal and transverse sharp variations in the stiffness of the foundation systems that support the fill materials. A very deep flowfill layer (up to 35 ft deep) was placed below the approach slab but a Class 2 backfill was placed for the remainder of the approach roadway. The longitudinal change in the stiffness of the two materials was mostly noted at the sleeper slab (20 ft from abutment, see Figure 5.12). The base of the CIP walls extend about 8 ft from the back face of the wall providing stiffer support to the soil in this zone than to soil near the middle of the approach roadways. This resulted in sinking of the soil in the middle of the approach roadway relative to the sides of the roadway. The design and current deflected shapes of the roadway cross-sections were presented earlier in this section.

To avoid the problems presented above in the future, it is important that the designer ensures uniform or gradual change in the stiffness of the foundation systems supporting the approach roadways, both parallel and across the roadway. Also, high quality granular soil material should be placed beneath the sleeper slab and adequate drainage measures should be placed in that zone to collect and drain any excess water before it reaches and softens the underlying silty or clayey soil layers.

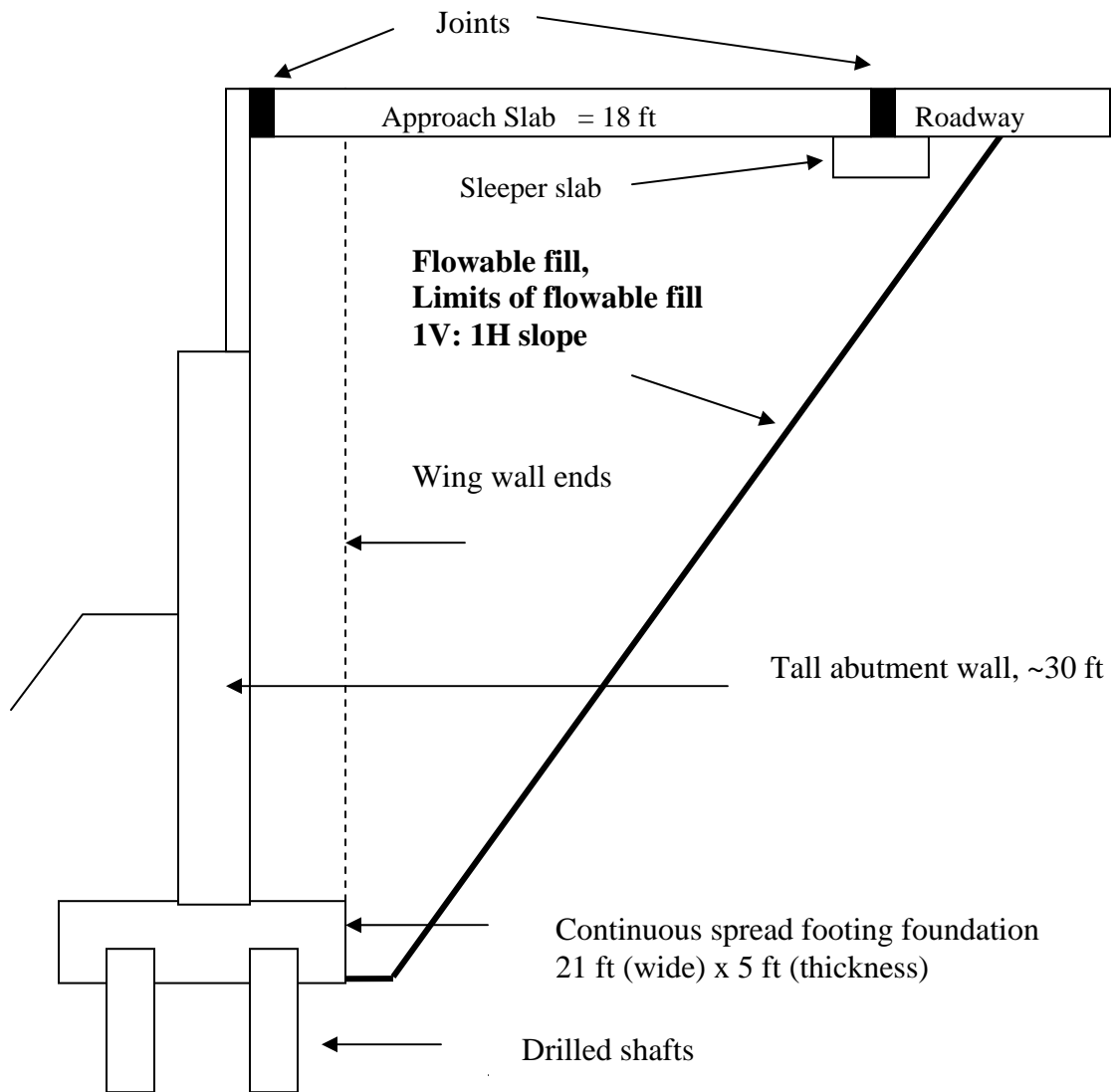

Figure 5.10. Details of the Eastern Abutment of the WB I-70 to SB I-225 Bridge.

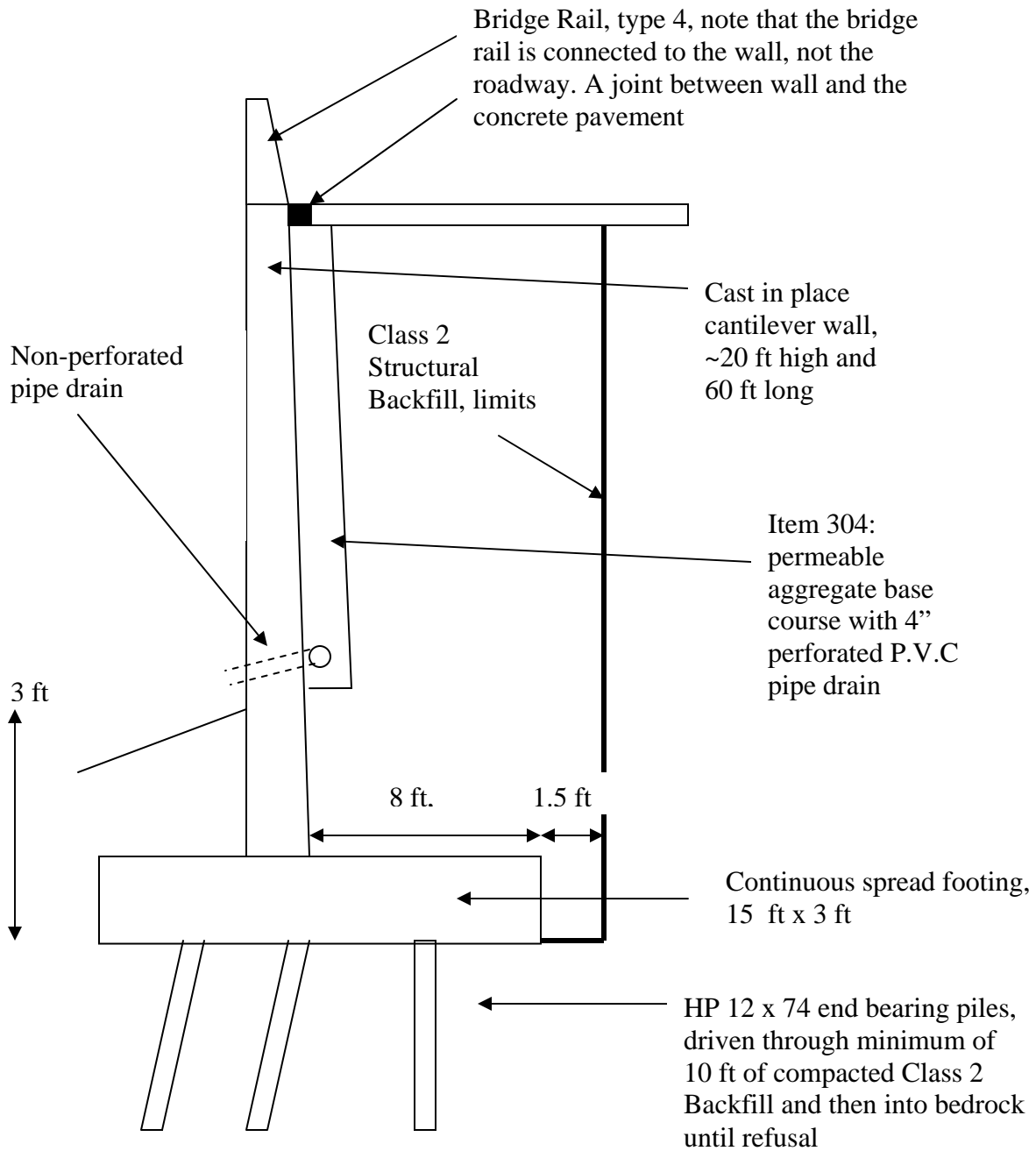

Figure 5.11. Details of the CIP Retaining Wall Constructed along the Northern-Eastern Side of the I-70/I-225 Ramp.

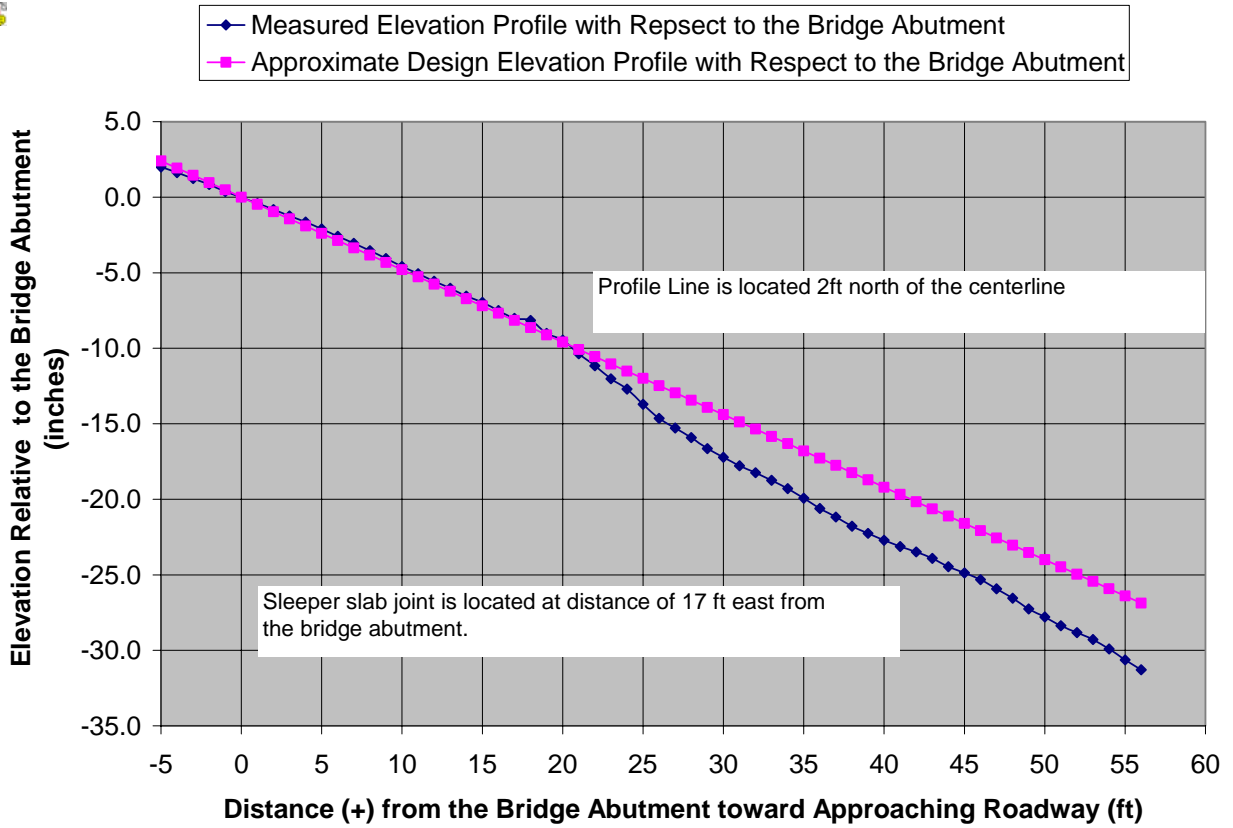
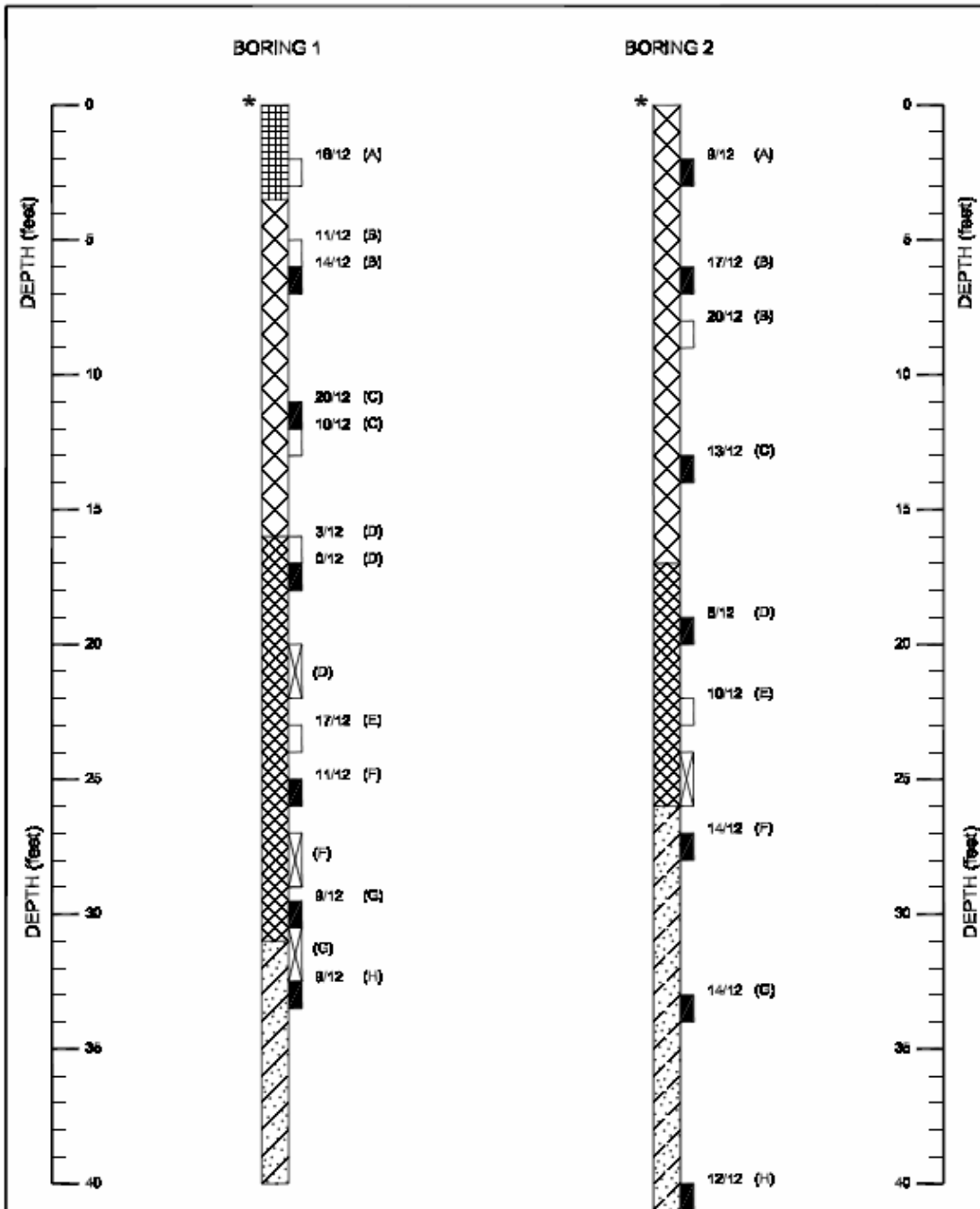

Figure 5.12. Elevation Profiles of the Eastern Approaches to the I-70/I-225 Structure.



* Note: 2' of Concrete above logged portion on both borings.

M03.0831.005	GEOCAL, INC.	BRIDGE ABUTMENT BUMP RESEARCH I-225 & I-70 BORING LOGS	FIGURE 1
--------------	--------------	---	----------

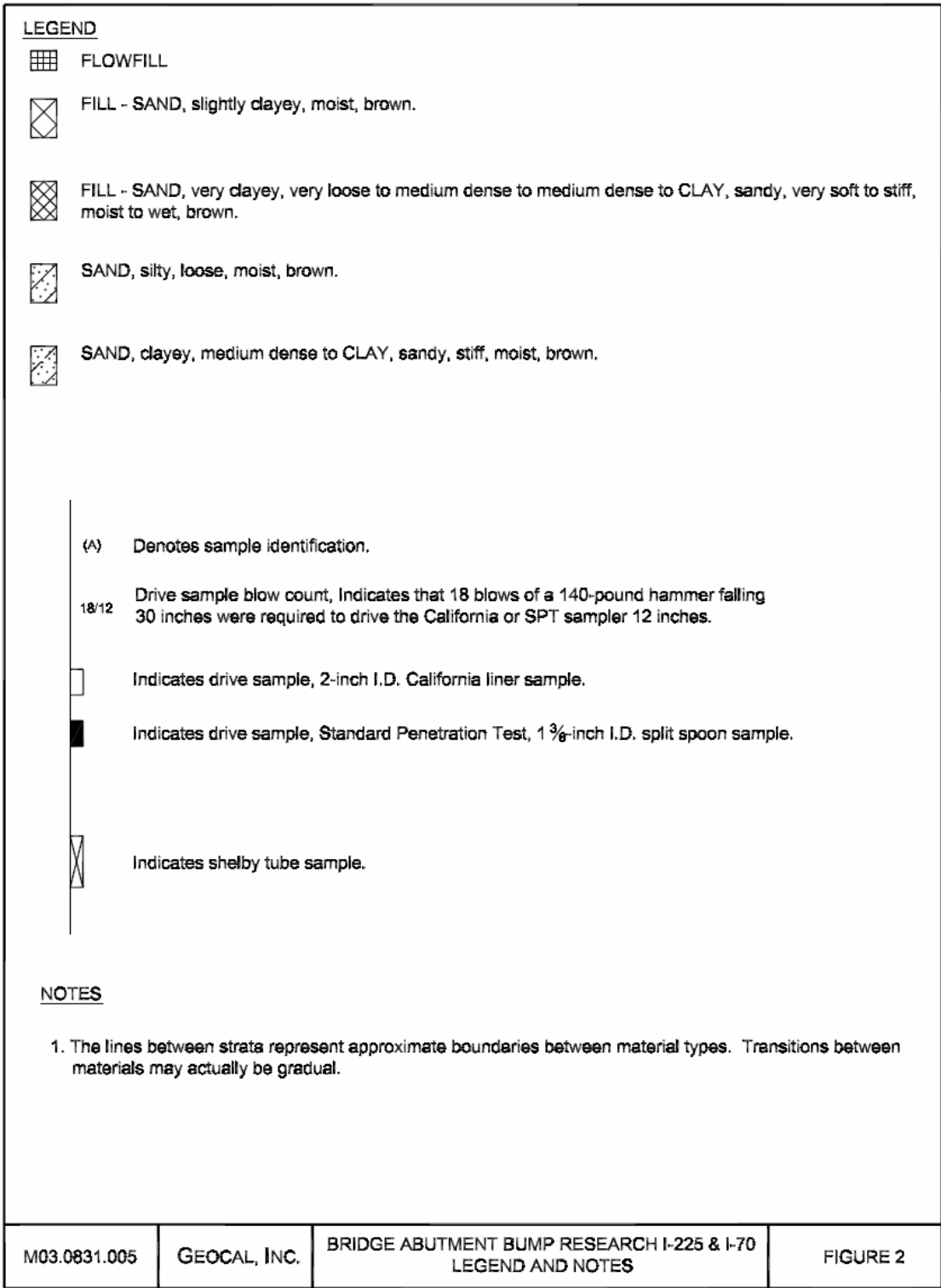

Figure 5.13. Boring Log for the I70/I225 Bridge Structure

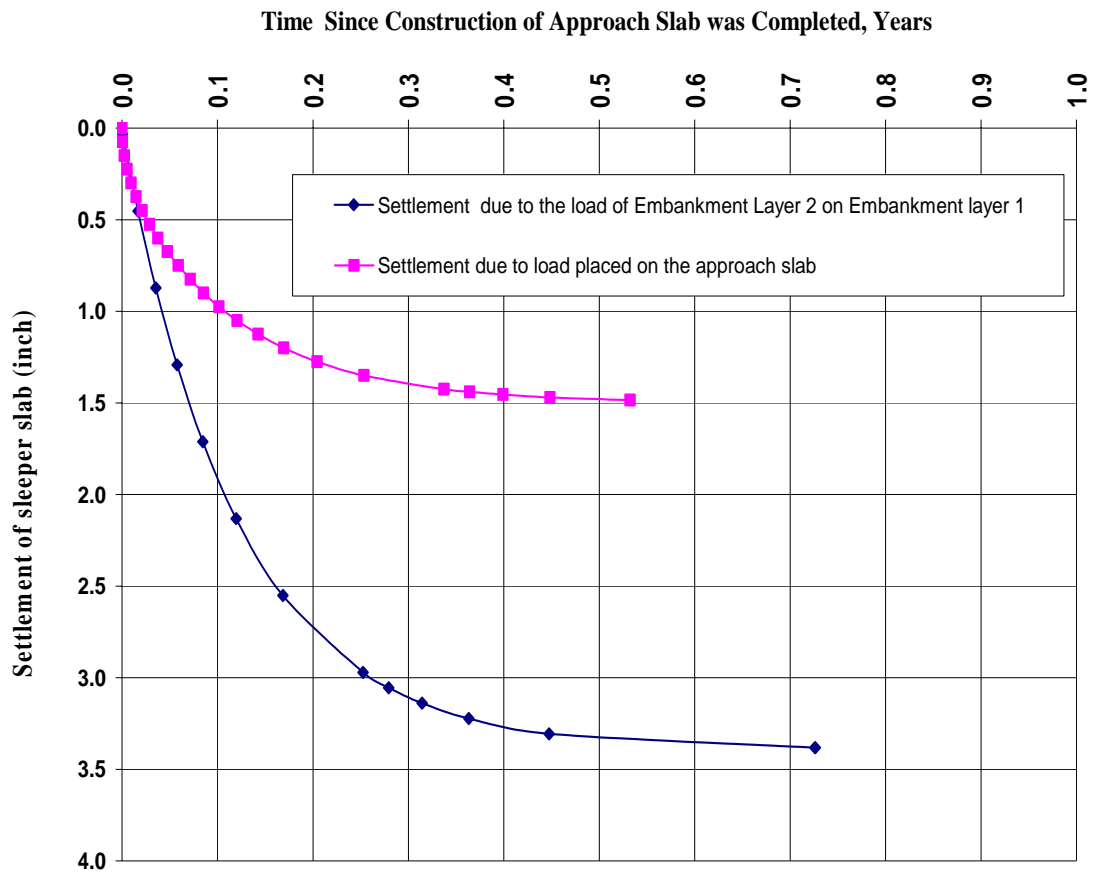

Figure 5.14. Predicted Sleeper Slab Consolidation Settlement of the I-70/I-225 Bridge Approaches.

5.4. SH 287 Over Little Thompson River (C-16-DK) (Flowfill Abutment Backfill)

5.4.1 Overview

The current SH 287 Bridge Structure over Little Thompson River (C-16-DK) is 93 ft wide, 14 ft high above water, and has four lanes. It replaced an older and a smaller bridge (Str. C-16-C, 30 ft wide, two lanes). This bridge is located 4 miles north of Longmont along SH 287. H-piles are employed to support the bridge abutment. Flowfill was selected for construction of the abutment backfill *because it is easier to place around an embankment slope.*

The severe bridge bump problem experienced at this bridge is clear in the break of the yellow line of the picture shown in Figure C.6. This severe bump and the high speed limit of 55 MPH cause uncomfortable rides for motorists. Field examination of the problem revealed no signs of bulging to the side walls or erosion. The Approach slabs (15' long), joints, and drainage systems all seem to be in good condition. Mr. Mike Day from Region 4 Maintenance wrote describing the bridge bump problem at this bridge: "All four lanes have a bump, and the north bound right lane is severe enough that the vehicles are leaving oil drops off the vehicles on the Bridge. The south bound side has some cracking but not sure if it is through both asphalt and concrete." *Mike also indicated that water is not effectively drained across the bridge (water accumulates).* According to Mike, the bridge bump problem started after completion of construction and it has been getting worse since then. The project engineer for this project, Mr. Larry Feuerstein, indicated that the sleeper slab settled 2" to 3" and that time of construction had nothing to do with this problem. *The problem, according to Larry, has to do with compaction of the embankment edges of the slope placed next to the flowfill. It is very hard to construct firm and well compacted sloped sides.* To ensure adequate compaction for edges of the embankment fill, it was required in the construction plan to build (place and compact) the embankment along 2H: 1V slope a minimum of 2 ft above the planned bottom level of the flowfill and then to remove it to the planned bottom level of the flowfill. *Another alternative would be to construct the slope in steps that would also reduce the need to use flowfill.*

The study investigation of the bridge bump problem focused on the southeast corner of the bridge where the problem was the worst. *Most of the new bridge was constructed east of the old bridge*

(alignment was changed) and this could explain why the problem was more severe on the east side of the bridge. The construction plans also revealed that 10 ft of new fill was added above the grade of the original ground of the south side. Much smaller fill was added on the north side of the bridge above the original existing ground and this may explain why the settlement problem was more severe on the south side than the north side. According to the design engineer for this project, Mr. Johnny Olson from Region 4, construction of the east side of the bridge took place during the summer of 2000 and lasted for approximately two months.

5.4.2 Results of the Subsurface Geotechnical Investigation

Along the southwest side of the structure, two borings were drilled 4 ft from the edge of the shoulder (shoulder is 10 ft wide). Boring 1 was located in the approach roadway about 4 ft from the sleeper slab joint. Boring 2 was located in the approach slab 4 ft from the sleeper slab joint. For these two borings, Figure 5.15 shows a log of the encountered subsurface materials, driving resistance results in term of N-values collected from the SPT and California Samplers, and locations and types of all collected samples. The foundation soil was encountered at a depth of 10 ft. Above that depth, flowfill was encountered in Boring 2 and flowfill and embankment material were encountered in Boring 1. The log results suggest that the N-values obtained from SPT and the California Sampler are comparable.

5.4.2.1 Fill Materials

The flowfill encountered in Boring 1 was very stiff and dense as reflected in the high N-values (72 to more than 100). Near the sleeper slab on the roadway side, the flowfill was much weaker and can be described as medium dense based on the measured N-values (14). *This suggests that the placed flowfill was not uniform and was of lower quality in some areas. It is also possible that water penetrated the flowfill around the sleeper slab and degraded it.*

Table 5.4 and Figure 5.15 list all the laboratory and field test results on the embankment material. The embankment material is described as a medium stiff A-4 soil ranging from sandy silt to silty

clayey sand to sandy lean clay. The measured density values and the relatively low N-values suggest that the compaction requirements for the embankment material were not met.

The measured water contents of the embankment material were above the optimum water content and very high. *This suggests failure of the drainage measures employed in the project to prevent surface and ground water from reaching the fill.* The degree of saturation ranged from 84% at a depth of 3.5 ft to 88% at a depth of 9.5 ft. These high degrees of saturation level and the fairly long period since construction was completed (4 years) suggest that the chances of further softening or settlement to the embankment in the future due to increase of moisture content are minimal.

Table 5.4. Laboratory and Field Test Results for the Embankment Material at the SH 287 Bridge.

Modified proctor test results for the embankment material, AASHTO T-99 are: Maximum dry density values 119.5 pcf with optimum moisture content of 12.3%. See the results for the sample at depth of 8 ft.										
Depth (ft)	N-(bpf)	γ_d (pcf)	w (%)	% gravel	% sand	% Fines	LL (%)	PI (I)	Consistency	Classification & Description
Requirements for the Embankment Fill Used in this Project										
		>113.5	>10.3							
Test Results from Boring # 1										
3.5	7	113.2	15.7	1	40	59			Medium Stiff	A-4 (0), Sandy Silt (ML)
8	6		14.4	1	58	41	23	6		A-4 (0), Silty Clayey sand (SC-SM)
9.5	6	109.9	17.8	1	49	50	25	9		A-4 (2), Sandy Lean Clay (CL)

5.4.2.2 Foundation Soil

Table 5.5 and Figure 5.12 list all the laboratory and field test results on the foundation clayey soil layer. The pocket of granular material encountered between the compressible clay layers can be described as medium dense well graded sand with silt. Most of the foundation soil layer can be described as very soft to soft sandy lean clay. In term of compressibility, it can be described as “*slightly to moderately compressible.*” The initial degree of saturation of the foundation clayey soil was 75% and water was added at the beginning of the consolidation test to saturate it. This

procedure accounts for any settlement that could occur in the future due to increase of moisture content. Very small creep index values were measured for the foundation clayey soil layer.

At the transition between the flowfill and the foundation soil and between the embankment and the foundation soils, very wet and soft soil conditions were encountered, so soft that a sample could not be collected.

Table 5.5. Laboratory and Field Test Results for the Foundation Soil of the SH 287 Bridge.

Depth (ft)	N-(bpf)	γ_d (pcf)	W (%)	% gravel	% sand	% fines	LL (%)	PI (I)	Consistency	Classification & Description
14		96	21.3	0	42	52	34	19		Sandy lean clay, A-6 (8), CL
15.5		99	21.9	0	32	68	35	18		Sandy lean clay, A-6 (10), CL.
17.5			27.8	0	18	82	35	23		Lean clay w/sand, A-6 (17), CL
Consolidation Test Results on Specimen collected from Depth of 14 ft (see description above)										
Water was added at the start of the test to fully saturate the samples, swelling is negligible.										
Saturation level increased from 75.2% to 100%, specific gravity is assumed 2.72, $e_0=0.769$										
C_c	$C_c/(1+e_0)$	σ'_c (ksf)	Load (ksf):	1	2	4	8	16		
0.235	0.13	1.81	C_v (ft ² /day):	0.07	0.14	0.11	1.41	0.08		
			C_α	0.003	0.003	0.008	0.006	0.005		

5.4.3 Settlement Analysis of the Sleeper Slab

For the consolidation settlement analysis, a $C_c/(1+e_0)$ value of 0.02 was assumed for the 4 ft flowfill, 0.05 for the 6 ft embankment layer, and 0.13 for the clayey foundation soil layer (total length 16 ft) and 0.02 for the sandy foundation soil layer that extends to a depth of 38 ft (see the log of Boring 1 in Figure 5.15 for the extent of all these layers). The coefficient of consolidation of the foundation clayey layer was assumed 0.14 ft²/day and the length of the longest drainage path was taken as 8 ft. Consolidation of other soil layers is assumed to occur instantly upon application

of the load. It is assumed that the construction time for the entire approach slab system (embankment and fill, approach slab roadway) was 2 months.

The sources of settlement of the sleeper slab after construction was completed are:

- The time dependent consolidation settlement of the clayey foundation soil layer due to the 10 ft fill load.

Results: settlements of 4.3". Most of this settlement will occur during the first 18 months after construction is completed (Figure 5.16).

- The time dependent consolidation settlement of the fill and foundation soil layers due to the dead and live loads carried by the approach slab and transferred to the sleeper slab. This load is assumed to generate a bearing pressure of 700 psf under the 4 ft wide sleeper slab.

Results: Total settlement of 1.09" (0.54" in the fill and 0.54" in the foundation). If the granular fill was well compacted, the settlement in the fill would drop by 50%. Most of this settlement will occur during the first 18 months after construction is completed (Figure 5.16).

- Creep or long-term time dependent settlement under constant load. In the clay layer, this settlement would be less than 0.5" over 10 years since construction was completed.

5.4.4 Concluding Remarks

Settlement at the SH 287 structure appears to have been caused by two mechanisms:

- *Settlement of the foundation clay layer due to new fill placed above the original ground level. Very soft to soft compressible clay soils with a low blow count (<3) were encountered below the fill, and this is believed to be the primary cause of the observed settlement problem at the site. The presence of this soft clay layer was not reported in the foundation report, possibly*

because the geotechnical investigation may have been performed when the foundation soil was dry.

- ❑ Settlement of embankment fill that was poorly compacted. Evidence for this comes from somewhat lower blow counts than would be expected for well-compacted embankment materials and from the measured compaction level (measured 92% to 95%, 95% is required) on some recovered soil samples. But the settlement from embankment materials is small (only 0.5”) compared with the actual settlement observed at the sleeper slab.
- ❑ Failure of the placed drainage measures to keep the surface water from reaching the fill and the foundation soil layers and/or the rise of the GWT. *The excess water softened the silty-clayey portion of the embankment soil layer and the upper portion of the foundation clayey soil layer. The top surface of the foundation clayey soil layer was found to be very soft and wet, so soft and wet that a sample could not be collected.* It is unlikely that the top of the foundation soil layer was as soft during construction as measured here, because then the foundation soil would not be able to carry the construction equipment. *Most likely, the top layer of the foundation soil layer desiccated under surface drying that made the project personnel think it was firm as required in CDOT construction specifications.* Then, as was the case for the I-70/I-225 project, the water infiltrated through the permeable embankment material, accumulated on top of the relatively impermeable clayey foundation soil layer, and softened the dried foundation soil layer. *It is also possible that softening of foundation clay layer resulted from the rise of the GWT which is located at relatively shallow depth. Accumulation of water on the top of a soil layer may soften it if it is well compacted but will significantly soften it if it is dried and not compacted. Some drainage should be installed from the sides of the structure to remove the water from the interface zone between the embankment and foundation.* This is especially important for the zone below and around the sleeper slab where the approach settlement problem occurs (e.g., place a stiff drainage layer below the sleeper slab).

Other important conclusions:

- ❑ *The time to complete most of the consolidation settlement was relatively short (1.5 years) because: 1) the clay foundation layer is only 16 ft thick, and 2) the presence of intermediate and bottom drainage sandy layers that reduced the length of the drainage path during*

consolidation of the foundation clay layer. The measured preconsolidation pressure, σ'_c , is very close to the vertical earth pressure calculated under normally consolidated conditions. This is strong evidence that most, if not all, the consolidation settlements have occurred.

- Settlement of the sleeper slab is controlled by the embankment material and the foundation soil layers placed beneath the sleeper slab, not the abutment fill layer. This is because the abutment fill extends just 4 ft below the sleeper slab. If this 4 ft layer was Class 1 backfill it would be compacted and considered overconsolidated with relatively high stiffness value, not much less than the stiffness of the flowfill. To reduce the potential for approach settlements, more of the high quality abutment fill should be placed around and below the sleeper slab.*

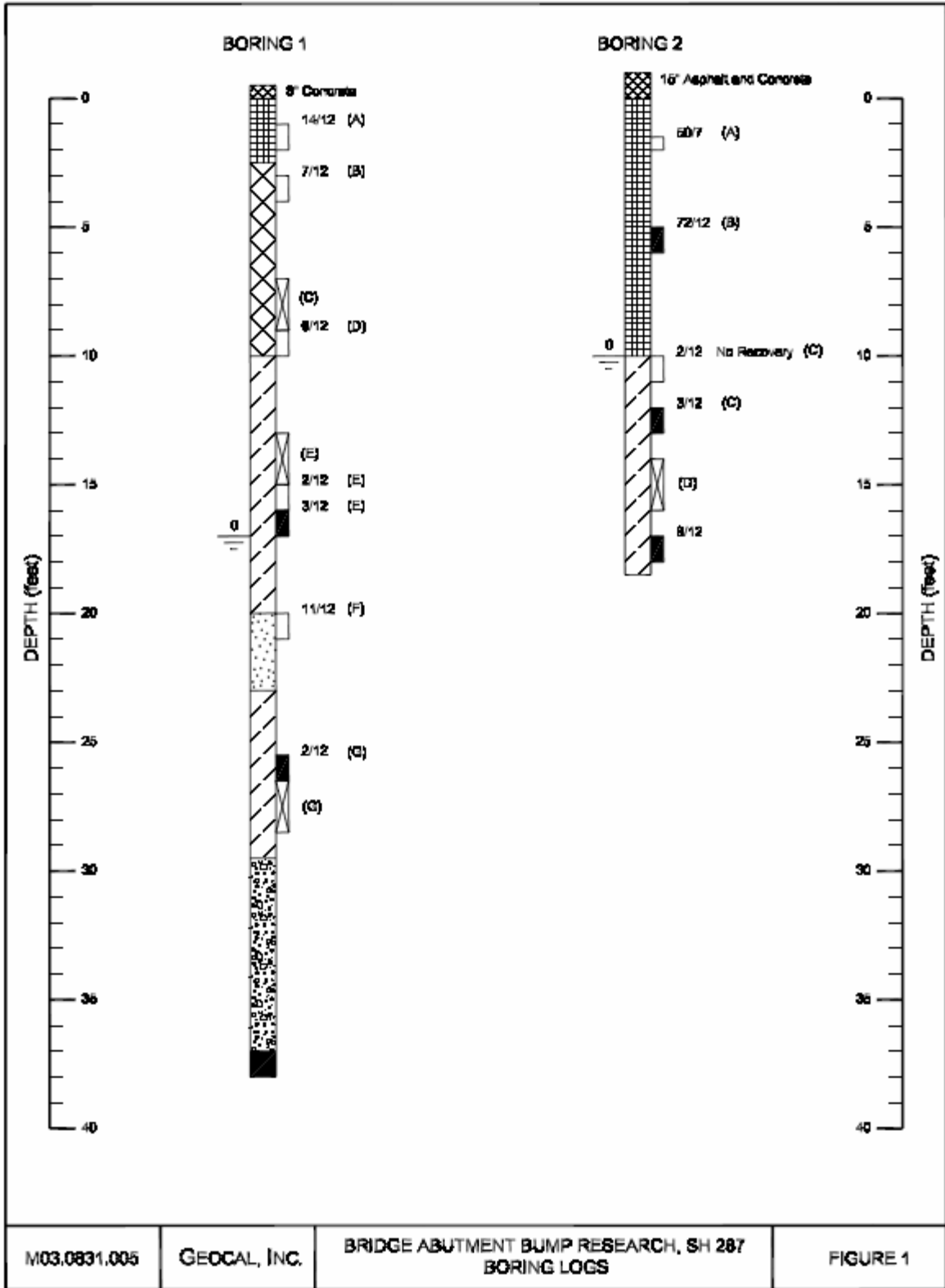

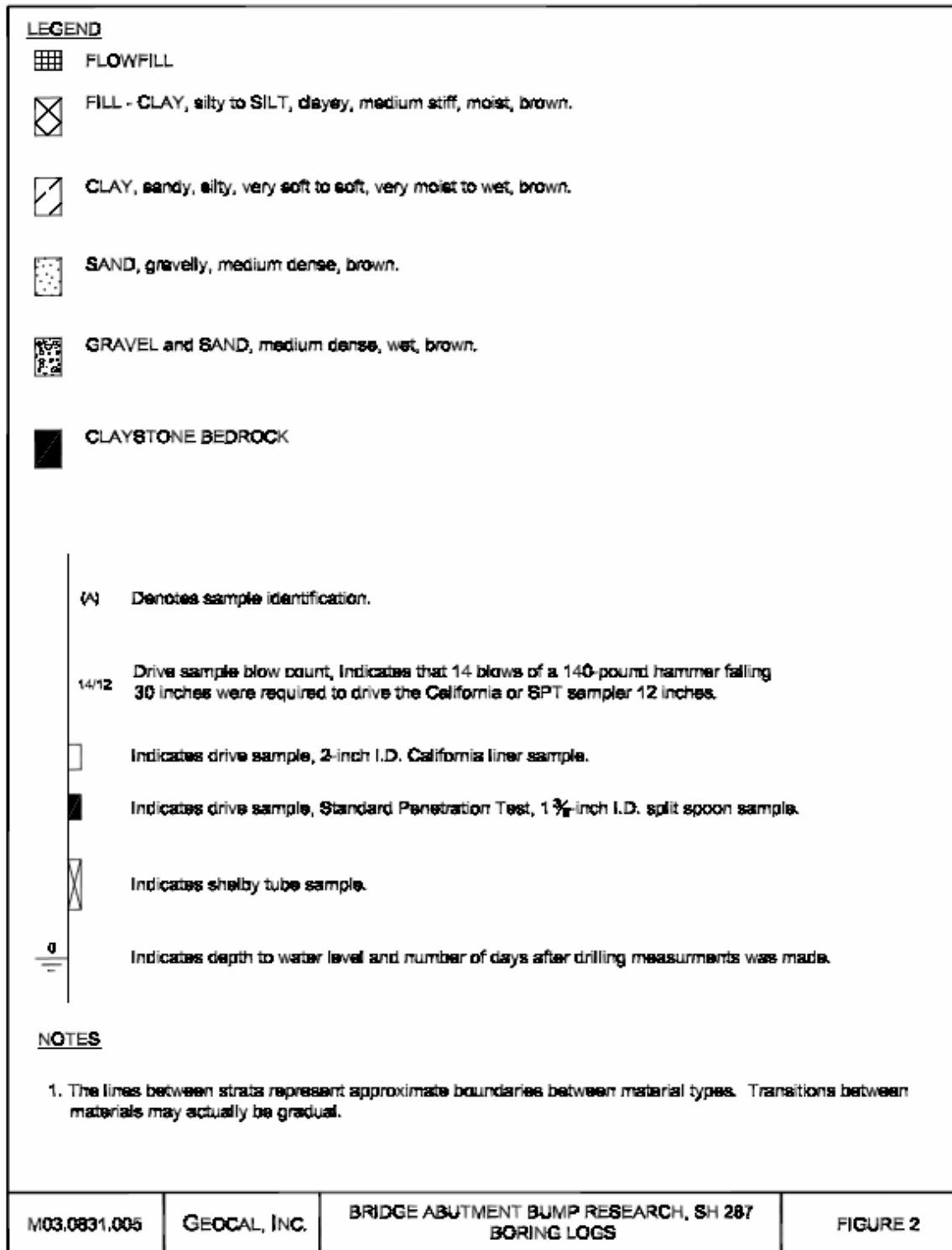

Figure 5.15. Boring Log for the SH 287 Structure

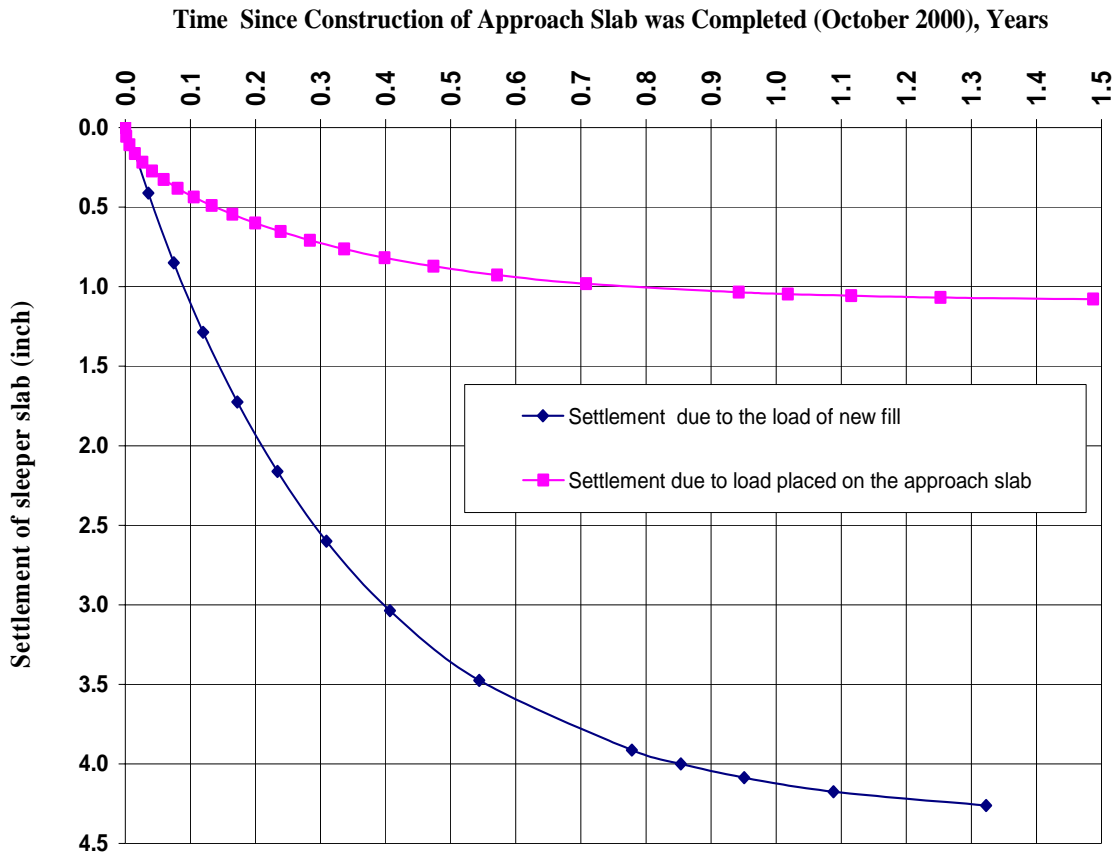

Figure 5.16. Predicted Settlement with Time at the Sleeper Slab of the SH 287 Bridge.

5.5. Structure E-19-Z on US 36 East of Bennett (MSE Abutment Backfill)

Mr. Alan Hotchkiss from CDOT Soils and Foundation Office completed a subsurface investigation on both sides of structure E-19-Z on US 36 at Milepost 90.2, East of Bennett. Hotchkiss (2004) wrote a report documenting this work and the possible causes of the approach settlement problem. This report was reviewed by Mr. C.K. Su from CDOT Soil and Foundation office. The materials presented next are extracted from that report, unless otherwise stated.

5.5.1 Site Conditions and Observations of the Problem

The construction for this structure was completed in 2000. The structure spans the terraced river bottom of Kiowa Creek. The new roadway is built on a previously engineered embankment of age greater than 40 years. This area receives low moisture but heavy afternoon thunderstorms in the warmer weather that creates high water flows on the structure for short time periods. Asphalt curb runs continuously from approximately 40 feet east and west of the structure to an asphalt drop structure (drain) designed to move water off the roadway and structure to the river terrace. The two drains are located on the **north** side of the structure. Both were filled with sand, gravel, and weeds rendering them virtually useless (Figure C.15). *After initial settlement of the sleeper slab made it impossible to move water off the roadway and structure, CDOT Maintenance cut out slots in the asphalt curb at the ends of the wing walls to facilitate water removal.* The wing walls show separation and movement away from the approach slab at some locations. No indication of a wash out of the fill was observed.

The settlement was observed at the sleeper slab (14 ft from the abutment) on the east side (2 inches) and west side (3 inches). Settlement is more pronounced on the northwest corner of the structure (Figure C.15). Mr. Roman Jauregui from CDOT Region 1 collected approach elevation profiles at all corners of the structure. The results for the NW corner, documented in Figure 5.17, suggest a settlement of 3 inches at the sleeper slab.

5.5.2 Subsurface Geotechnical Investigation

The Creek bed was dry at the time of drilling. Four test borings were drilled within 3 feet of the sleeper slab. The ground water table was encountered at 25 feet below the roadway surface during the drilling.

The encountered aggregate base coarse (fine, sandy gravel) is *moist and very loose to loose at depths of 1 to 3 feet*. The embankment fill consists of medium brown, sandy clay reinforced by a geotextile wrap, ranging in depth from 3 to 17 feet. The fill was moist and medium stiff to stiff. Some undisturbed claystone nodules were noticed in the fill. No voids were encountered in the fill but the material was loosely compacted. The majority of the fill had been removed, stored on the creek terrace, and then re-compacted with geotextile using a “burrito wrap” method back into the embankment. The underlying native sand and gravel (foundation) was very moist to wet and loose to medium dense at 16 to 25 feet.

5.5.3 Causes of the Approach Settlement Problem

Alan Hotchkiss (2004) believed that the settlement in the sleeper and approach spans are the result of localized consolidation of the embankment materials. The embankment was constructed during the winter months and maintenance personnel observed sudden and rapid settlement of the newly constructed embankment once the ground thawed in late spring. Continued settlement has occurred due to loss of fines via water intrusion into the embankment and the probable breakdown of intact claystone nodules found in the fill. This has occurred at the sleeper slab expansion joints and at the asphalt cutouts near the wing walls where water has flowed into and under the approach and sleeper slabs.

5.5.4. Repair of the Approaches

Based on the field test results, Alan Hotchkiss (2004) recommended the use of high pressure compaction grouting for this situation. Later in 2004, the bridge approaches were fixed with the compaction grouting. It is recommended that the long term performance of compaction grouting be monitored.

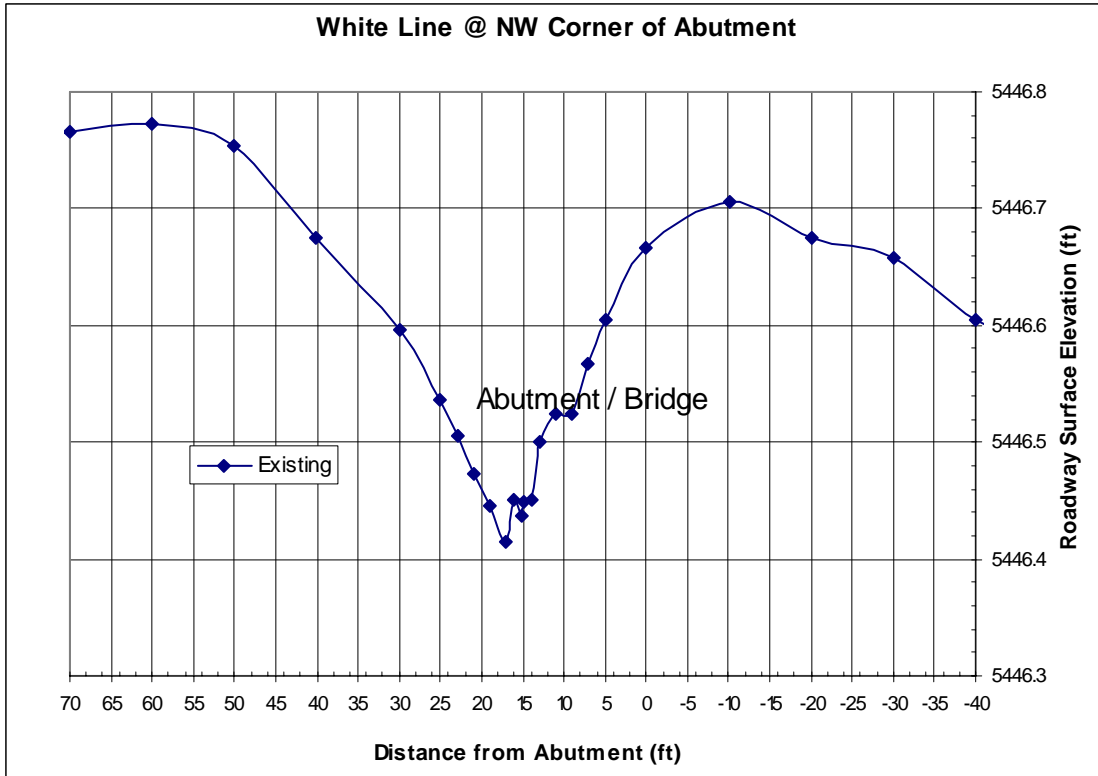

Figure 5.17. Elevation Profile of the Approaches of Structure E-19-Z Before It Was Repaired.

5.6 Structure E-17-PR @ I-76 at 136th Ave (Flowfill Abutment Backfill)

Mr. Ilyess Ksouri (2001) from CDOT Soil and Foundation office completed a subsurface geotechnical investigation at the east and west approaches of the subject structure. The purpose of the investigation was to identify causes of the approach slab settlement problems and to provide recommendations for remedial measures. The report prepared by Ksouri (2001) was reviewed by Mr. C.K. Su from CDOT Soil and Foundation office. The materials presented next are extracted from that report.

5.6.1 Site Conditions:

The Structure is a two span bridge at 136th Ave. and carries traffic over I-76. A site visit revealed that the approach and roadway concrete slabs and the slope paving settled quite noticeably at both sides of the bridge. The amount of damage is much more severe at the southeast (SE) bridge approach. The joint between the side walls and the approach roadway allowed water to get into the embankment materials. This resulted in localized erosion under the approach slab.

5.6.2 Subsurface Geotechnical Investigation

A total of six test holes were drilled at the east and west approaches.

At the west abutment, subsurface conditions in boring B2 at the approach slab consists of a 12-inch thick layer of reinforced concrete underlain by 8 feet of flowable fill (cemented gravelly sand material) and 10 feet of natural clayey sand material (foundation soil). The weathered claystone bedrock was encountered at a depth of 19 feet below grade. The clayey sand material (foundation soil) varies in density *from very loose to medium dense*, with a moisture *content varying from 19 to 22%* and a plasticity index varying from *23 to 26*. Drilled holes B1 and B6 at the roadway approach consist of a concrete slab varying in thickness from 12 to 14 inches, underlain by 8 feet of clayey sand fill material and 5 to 10 feet of natural sandy clay material. The weathered claystone bedrock was encountered at a depth of 19 feet below grade. The clayey sand fill material

is *very loose to loose*, and the sandy clay natural material (foundation) is *very moist* and plastic with moisture content varying from 22 to 25% and a plasticity index of 35.

At the east abutment, drilled hole B4 at the approach slab consists of a 12-inch reinforced concrete slab underlain by 8 feet of flowable fill and 7 feet of clayey sand fill material. Beneath the fill material, 17 feet of sandy clay to clayey sand natural materials were encountered. The weathered claystone bedrock was at a depth of 31 feet below grade at this location. *The fill material is loose to medium dense* with a moisture content of 13%. The sandy clay natural material (foundation soil) is medium stiff to stiff with moisture content of 21% and a plasticity index of 28. The clayey sand natural material (foundation soil) is *loose to medium dense*. At the roadway approach, drilled holes B3 and B5 consist of 3 feet of flowable fill underlain by 7 to 10 feet of clayey sand and sandy clay fill material. Twenty feet of sandy clay to clayey sand natural materials were underneath the fill material. The weathered claystone bedrock was encountered at a depth of 31 feet below grade. The fill material at the SE bridge approach is *soft to medium stiff* and *very moist* with a moisture content of 22% and a plasticity index of 26.

5.6.3 Causes of the Bridge Approach Settlement Problem

Ksouri (2001) indicated that the approach settlement resulted from the compression and erosion of the embankment fill, and consolidation of some of the foundation soil layers.

It is very common for water to infiltrate at the expansion joint and along the bridge wingwall into the embankment fill. The infiltration of water can have different degrees of effect on reducing strength and increasing deformability of the embankment materials. The lab results showed very soft and excessive moist embankment material at the SE bridge approach that gets stiffer and drier with depth. This indicates infiltration of water from the surface into the embankment materials. The combination of excessively moisture in the embankment and repetitive traffic loading, induced settlement of the embankment material.

Water from surface run off could also wash out the embankment material creating voids underneath the approach and roadway slabs. Localized erosion underneath the slab at the SE

wingwall area was observed during the site investigation. Erosion of the embankment material will lead to further settlement of the approach and roadway slabs.

The embankment fill material is predominantly clayey sand and sandy clay with SPT blow counts between 2 and 7 measured during the subsurface investigation. Ksouri (2001) stated that the relative low SPT blow counts (4 or below) of the embankment fill resulted from: 1) excessive moisture, and 2) varying and low degrees of compaction efforts at some locations of the embankment during construction.

5.6.4 Recommendations

Based on the above findings and the limited subsurface investigation, Ksouri (2001) suggested the following measures to be considered for solving the approach slab settlement problem:

(1) Drainage Improvement:

Deck drains to collect the water before it reaches the approach slabs should be installed. Water collected by the deck drains should be piped to the bottom of the embankment fill. The new drainage system should discharge water to the bottom of the concrete apron areas. All the gaps between the wingwall and the concrete pavement should be properly sealed to eliminate infiltration of the surface water into the embankment material.

(2) Compaction Grouting or Polyurethane Deep Injection described in Chapter 2.

6. PERFORMANCE OF THE FOUNDERS/MEADOWS MSE BRIDGE APPROACHES OVER 5 YEARS

6.1 Introduction

The construction of the unique Founders/Meadows structure was completed in 1999 near Denver, Colorado. It carries State Highway 86 over Interstate I-25. In the Founders/Meadows bridge structure, geosynthetic-reinforced soil (GRS) walls were employed (see Figure 6.1) to support the shallow footings of a two-span bridge and the approaching roadway structures. Figure 6.1 shows a typical cross-section through the “front GRS wall” and “abutment GRS wall.” The figure illustrates that the front GRS wall provides direct support for the bridge and approaching roadway structures. A short reinforced concrete abutment wall and two wing walls, resting on the spread foundation, confine the reinforced backfill soil behind the bridge abutment and support the bridge approach slab. The reinforced soil system not only provides bridge support, but it was also designed to alleviate the common bridge bump problem, as discussed later. This structure was considered experimental. Section 800 (Figure 6.2) was heavily instrumented to evaluate the performance and design procedure of this structure, including an assessment of CDOT design procedure to alleviate the bridge bump problem (Abu-Hejleh et. al., 2000). The study findings on the performance and design assessment of the front GRS wall supporting the bridge superstructure were presented by Abu-Hejleh et. al. (2001). This chapter will present and discuss the data collected on the performance and design assessment of the Founders/Meadows Bridge MSE approaches. This will provide insight into the behavior and validity of some of the design assumptions of CDOT MSE and Flowfill bridge approaches.

6.2 Overview of the Study Investigation

The main cause of uneven settlements in typical bridge foundation systems is the use of different foundation types. That is, while the approaching roadway structure is typically founded on compacted backfill soil, the bridge abutment is typically founded on stronger soils by deep foundations. To overcome this problem, the approaching roadway embankment and the bridge

footing were integrated at the Founders/Meadows structure with an extended reinforced soil zone in order to minimize uneven settlements between the bridge abutment and approaching roadway (Figure 6.1). Differential settlements can also be caused by erosion of fill material induced by surface water runoff. Several measures were implemented in this project to prevent that surface water and groundwater from reaching the reinforced soil mass and the bedrock at the base of the fill. This included placement of impervious membranes with collector pipes at the top of the MSE backfill beneath the approach slab (Figure 6.1). To further keep water away from the structural fill, at the interface of the backfill and the existing ground, a wick drain filtration and collection system was installed to intercept/divert the seepage and ground water from the reinforced soil mass (Figure 6.1).

Finally, differential settlements can also be caused by continuous expansion or elongation and contraction of the bridge superstructure (deck and girders) due to daily and seasonal changes in air and superstructures temperatures. This is a more critical factor with the use of integral abutment (IA) bridges, as in the Founders/Meadows structure, where abutment walls are strongly attached to the superstructure (deck and girders) without joints. The approach slabs are tied to the bridge deck at each end of the bridge. As reported in the literature (Hoppe and Gomez, 1996), the elimination of the bridge joint shifted some of the maintenance problems encountered in the bridge deck to the adjacent fill structure. As the integral bridge abutment wall moves due to the expansion and contraction of the bridge girders and deck, it alternately pushes into and pulls away from the backfill and approach slabs behind the abutment wall, leading to the development of a void near the abutment wall under the approach slab. This could lead to the development of a void under the approach slab that contributes to the differential settlement between bridge abutment and approach slab. To alleviate this cause of differential settlement in the Founders/Meadows structure, the following measures were incorporated:

- A bridge expansion device was placed on top of the sleeper slab, between the roadway and approach slab, to accommodate the approach slab movement.
- A reinforced fill behind the abutment wall was used to build a vertical, self-contained wall capable of holding an approximately vertical shape and forming a gap between the abutment and the reinforced retained fill (Figure 6.1). A compressible 75 mm thick low-density

expanded polystyrene sheet was placed between the reinforced backfill and the abutment walls (Figure 6.1) to allow for development of a gap. It was hypothesized that this system would accommodate the horizontal expansion movements of the bridge superstructure without affecting the backfill and will reduce the induced lateral passive soil pressures from a very high value to a small value that the abutment wall would be able to resist. At the same time, this system would allow for the free expansion of the MSE backfill, thus allowing for mobilization of the shear strength of the abutment backfill and tensile resistance of the reinforcement, thus reducing the horizontal active soil pressure on the abutment wall. Therefore, CDOT engineers expected that this system will also reduce the backfill active horizontal pressure on the facing of the abutment wall to half or less of those occurring with other conventional abutment systems.

In order to investigate the performance of the measures described above to alleviate the bridge bump problem in the Founders/Meadows structure, several instruments (moisture gages, strain gages, and pressure cells) were placed in the abutment MSE backfill (Figure 6.2) and profilometer tests across the approach slab from approaching roadway into the bridge deck were conducted. Monitored data were collected from beginning of construction through five years of service. A complete description of these instruments and tests, including installation, use, and interpretation of raw data are presented in CDOT Report # 2000-5 (Abu-Hejleh et. al., 2000). This chapter will present the collected data from these instruments and tests over five years, and the design implications of the analyzed data. Note that construction of the Founders/Meadows was completed June 30,1999, corresponding to 180 days or 0.5 year from Jan. 1, 1999.

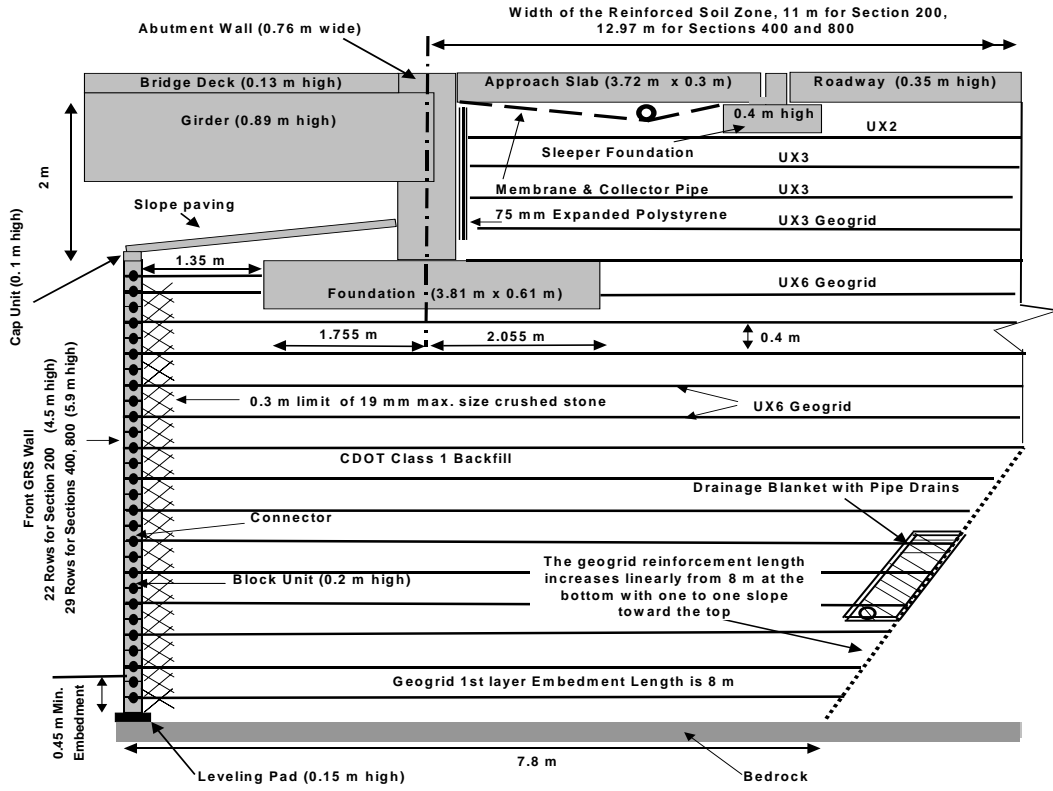

Figure 6.1. Typical Section through Front and Abutment GRS Walls of the Founders/Meadows Bridge Structure.

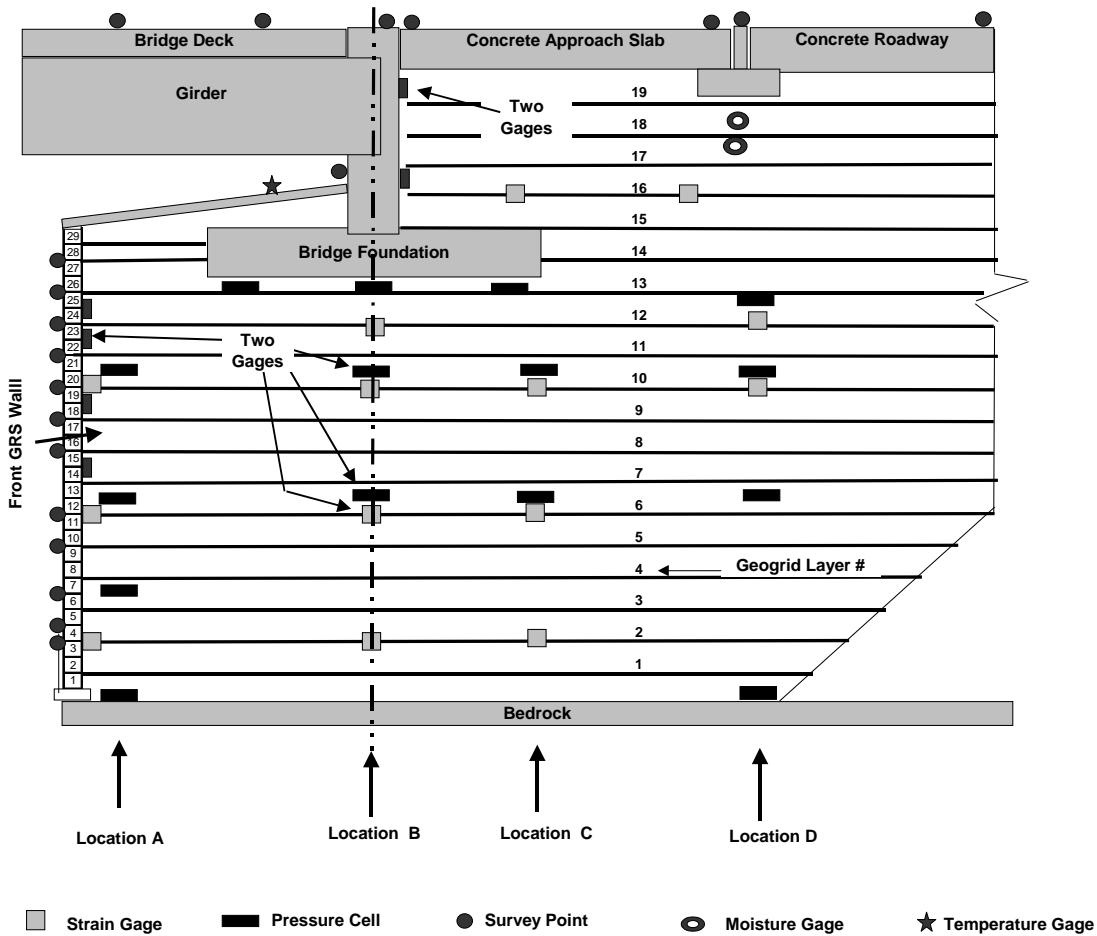

Figure 6.2. Instrumentation Layout of Section 800 of the Founders/Meadows Bridge Approaches.

6.3. Overall Performance of the Bridge Approaches

The Road Dipstick is a digital level with two pivoting feet that are 0.3 m apart, manufactured by Face Construction Technologies, Inc., of Norfolk Virginia. A digital readout shows the difference in elevation between the feet in increments of 1/1000th of an inch (0.025 mm). This digital profiler was used in this study to draw an accurate elevation profile relative to the elevation of the bridge abutment wall (assumed 0) of lines along the traffic direction located over and around the sleeper slab and approach slab (from bridge deck to approaching roadway) where the bridge bump problems often occur. Locations of the profile lines, covering the east and westbound traffic lanes of the east and west abutment walls (i.e. four edges of the bridge

superstructure), are shown in Figure 6.3. To check the development of the bridge bump problem with time, profiling data have been obtained several times (February 2000, August 2001, and March 2004) over the five service years since the bridge was opened to traffic. Figures 6.4 and 6.5 show relative elevation data collected along the four profiling lines. The elevation data are obtained in relation to the abutment wall, where the relative elevation is zero. Distances from the abutment wall to the approach slab are taken positive, while distances to the bridge deck are taken negative. Note that the bridge deck is lower than the approach slab across the east abutment wall and higher than the approach slab across the west abutment wall.

The results shown in Figures 6.4 and 6.5 indicate that the transition between the bridge and approaching roadway after five years in service is smooth and shows no signs of developing differential settlements between the bridge abutment and the approaching roadway (i.e. “bump at the bridge” problem). *The elevation profiles collected at different times essentially match each other, suggesting that settlements of the bridge superstructure and approaching roadway have been uniform.* That is, no evidence of differential settlement has been observed between the bridge superstructure and approaching roadway. *Thus, it could be concluded that the overall short- and long-term performance of the approaches of the Founders/Meadows structure is excellent because there is no evidence of the “bump at the bridge” problem after five years in service and even with no signs of structural distress to the approach slab and the bridge expansion device.*

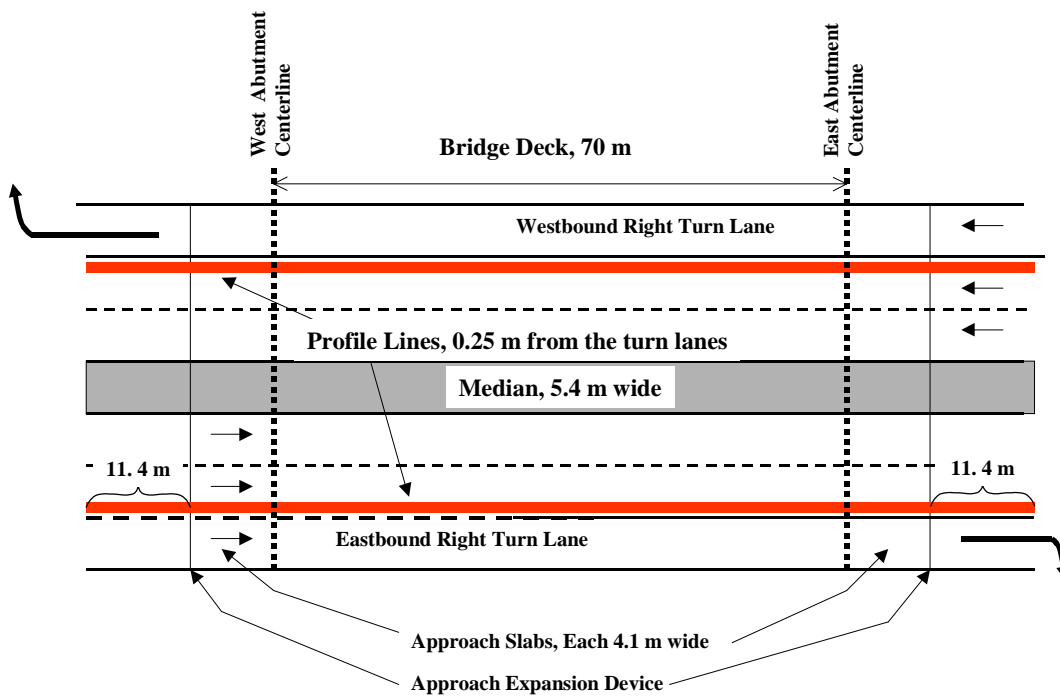

Figure 6.3: Locations of the Profiles Lines in the Founders/Meadows Bridge Structure.

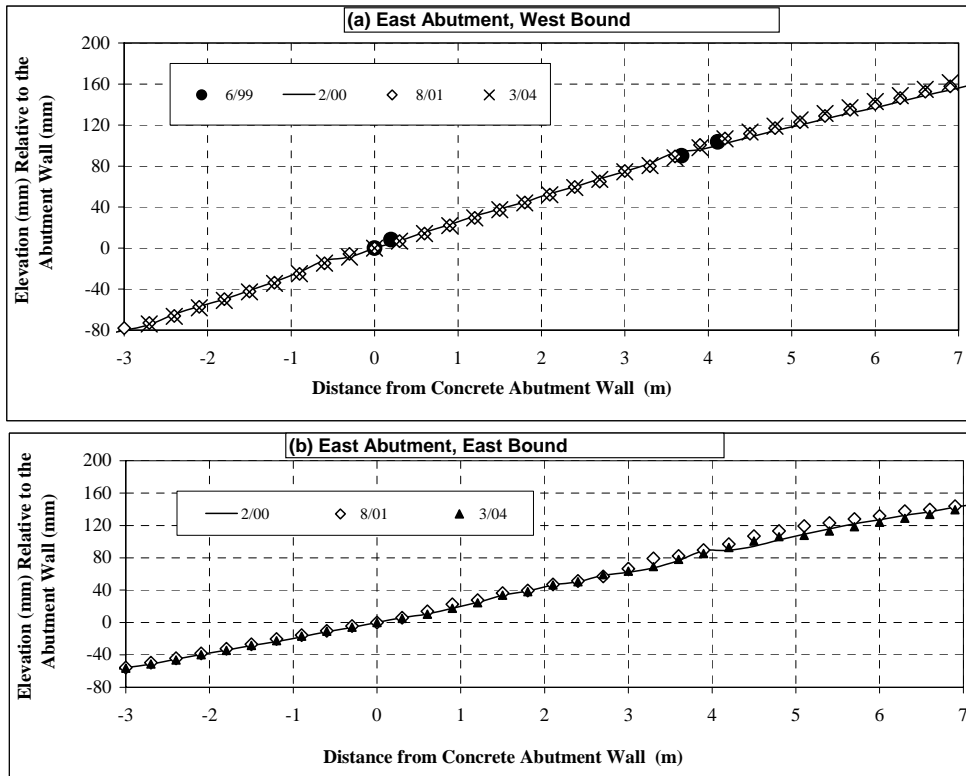

Figure 6.4: Measured Elevation Profiles Relative to the Bridge Abutment for Two Lines over the East Abutment along the Traffic Direction (Note: Distance from bridge abutment is + towards the approach slab and is - towards the bridge deck).

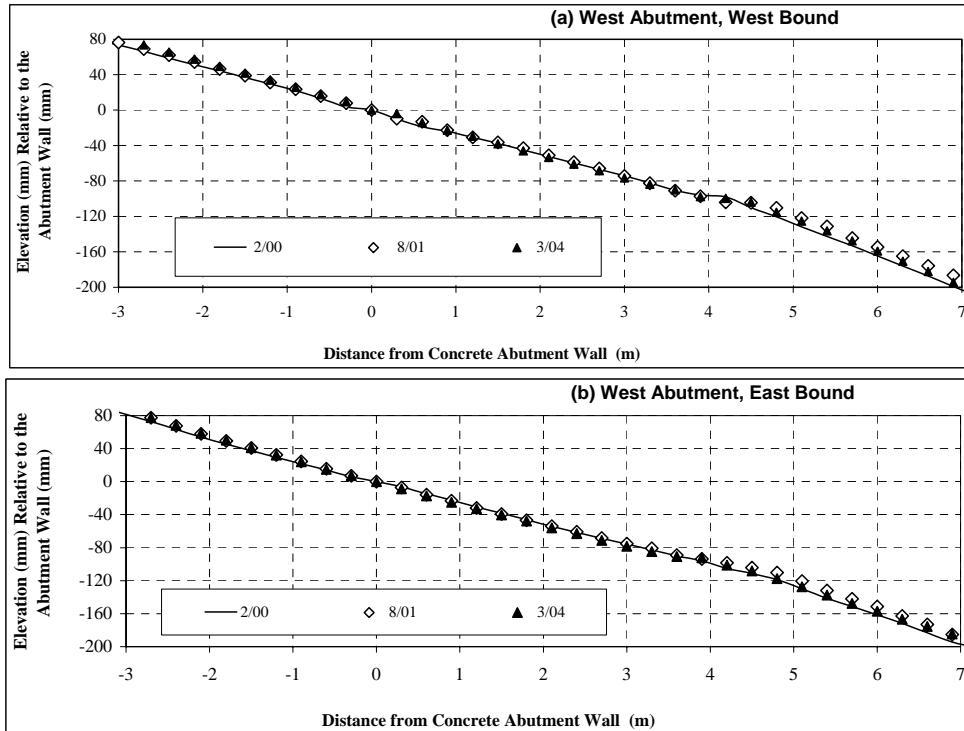

Figure 6.5: Measured Elevation Profiles Relative to the Bridge Abutment for Two Lines over the West Abutment along the Traffic Direction (Note: Distance from bridge abutment is + towards the approach slab and is - towards the bridge deck).

6.4. Moisture Changes in the MSE Abutment Backfill

Two moisture gages, manufactured by Campbell Scientific, Inc, were placed 0.1 m, and 0.5 m below the sleeper footing along Section 800 to measure soil moisture changes (Figure 6.2). Information obtained from these two gages was analyzed to determine the effectiveness of the design and construction measures implemented to prevent surface run-off and ground water from reaching the MSE abutment backfill. Data obtained from the moisture gages were in term of the volumetric water content, defined as volume of water over the entire volume. Figure 6.6 shows time records for measured changes in the soil volumetric water over five years. It is possible that the backfill placed over the moisture gage was not fully compacted in order to place and then protect the gages. Hence, the measured data should give an insight in the overall changes in soil moisture levels, not necessarily very accurate information on the typical volumetric water content that will be experienced in abutment backfill materials. The drainage protection system

(membrane and concrete pavement) was in place by June 30, 1999 (1/2 year from Jan.1, 1999). Before placement of the drainage protection system there were constant changes for soil moisture as seen in Figure 6.6. After placement of this system the changes in soil moisture at depth of 0.5 m seem to be more controlled.

The largest changes to soil moisture occur during the spring of each year (wetting and thawing season in Colorado, e.g. 1.25 to 1.5 year in Figure 6.6). This is the only season of the year where the build up of moisture occurs every year at depth of 0.5 m. In other times, the soil close to the surface at depth of 0.1 m felt the surface water, but the infiltrated water was drained out or distributed in the soil mass or dried out, because the wetting front did not reach the moisture gage placed 0.5 m below. For the soil at 0.1 m depth (closer to the surface) compared to the soil at 0.5 m depth, the presence of surface water during the wetting season was felt earlier, continuous fluctuations in the moisture level during all times of the years were observed, and the duration of the drying and wetting cycles were much shorter. The very large volumetric water contents measured at depth 0.1 m compared to those at depth 0.5 m may also suggest the soil at that depth is softer/looser. *All these results suggest that the surface water penetrated the upper zone of the reinforced soil mass below the sleeper slab through joints and cracks and the drainage protection system was not completely effective in preventing the surface water from reaching the abutment MSE backfill.*

At approximate depth 0.5 m, the soil moisture does not change and remain low during the winter season, increases during the spring time, and dries out during the summer and the fall seasons. The soil at depth 0.5 m seems to become fully saturated at the end of the spring season of every year (late June). *This seems to be the most critical time for design.* The maximum volumetric water measured late June of 2003 is higher than measured late June of 2001, which in turn is higher than measured late June of 2000. *This suggests gradual softening of the soil layer beneath the sleeper slab with time.*

Conclusions and Design Implications of the Measured Results

- ❑ Install temporary drainage protection measures during the construction stage before placement of the permanent drainage protection system.
- ❑ *The placed drainage protection system **was not** fully effective in preventing the surface water from reaching deep inside the reinforced soil mass. The backfill beneath the sleeper slab becomes fully saturated during late June of each year and should be designed for these conditions. Signs of gradual softening of the backfill placed beneath the sleeper slab with time due to increase of retained water by soil every year are noticed. This will lead to gradual backfill settlement with time.*
- ❑ The impervious membrane was placed just beneath the approach slab and was not extended to protect the soil beneath the sleeper slab where a joint is placed. This membrane should be extended to protect the backfill beneath sleeper slab.

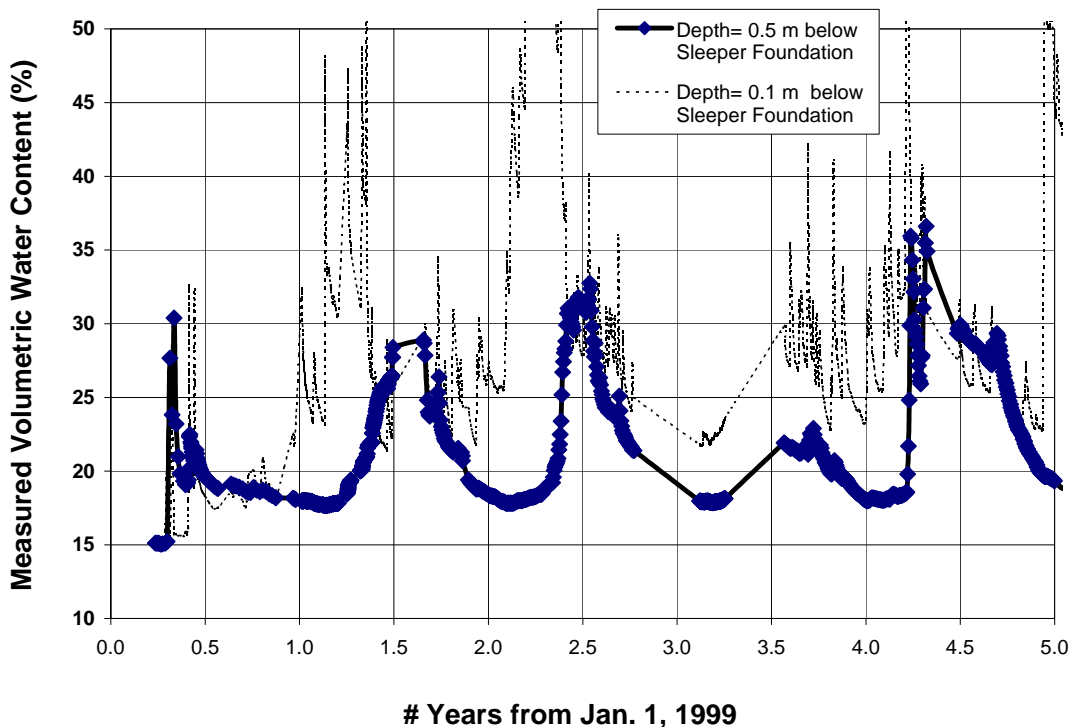

Figure 6.6. Measured Changes in Soil Moisture Before and After Placement of the Drainage Protection System.

6.5. Lateral Strains and Earth Pressures in the Abutment MSE Backfill

As discussed before, daily and seasonal changes of the temperatures have a great influence on the movements of the abutment wall, leading to influence on the measured reinforcement strains in the abutment MSE backfill and earth pressures behind the abutment wall. To record air temperature, one resistive temperature probe, manufactured by Geokon, was placed below the girders (Fig. 6.1), where the sun and precipitation could not reach it. The measured air temperatures from this gage over five years are presented in Figure 6.7. It is clear from this figure that the highest air temperatures occur around July of each year (e.g., 1.5 and 2.5 years from Jan. 1, 1999 in Figure 5.7), and the lowest air temperatures occur around January of each year (e.g., 2.0 and 4.0 years from Jan. 1, 1999 in Figure 6.7). The temperatures seem to rise up from March or May of every year (*warming season*, e.g., 2.15 to 2.4 years from Jan. 1, 1999 in all figures presented in this section), remain high around the summer time of every year from June to August (e.g., around 1.5, 2.5, 3.5, 4.5, and 5.5 years in the figures), decreased from September to November of every year (*cooling season*, e.g., 3.65 to 3.9 years in the figures), and remain low around the winter time from December to February (e.g., around 1, 2, 3, 4, and 5 years in the figures). The thermistors associated with each of the vibrating wire pressure cell and strain gages were used to measure backfill temperatures at the locations where these sensors were placed. Abu-Hejleh et. al. (2001) summarized and discussed the typical measured air temperatures, the soil temperatures at locations nearest the wall facing and farthest from the facing. Fluctuations between day and night temperatures are noticed for the air (Figure 6.7) and soil near the facing but disappeared for the soil far from the wall surface.

6.5.1 Measured Strains in the Reinforcements of the MSE Abutment Backfill

Two strain gages were attached to UX3 geogrid layer # 16 at 1.2 m (Location line C) and 3.4 m (Location line D) from the back of the abutment wall (Figure 6.2). Time records for the measured geogrid strain results during construction (completed 0.5 years from Jan 1, 1999) and after the bridge was placed into service during the following 4.5 years are shown in Figure 6.8. The fluctuations in the measured strains are due to the changes in temperatures from day to night. The response from the two strain gages is very similar and almost parallel, in support of

the consistency of the measured data. The long-term design strength or LTDS for UX 3 geogrid is 11 kN/m. *The maximum measured tensile strain is 0.3%, which corresponds to tensile stress of 3 kN/m. So there is adequate margin of safety against the breakage of these reinforcements.* A very rough estimate of the lateral expansion movement of the MSE abutment backfill toward the abutment wall at the level of the strain gages during various times is shown in Figure 6.9.

Figs. 6.8 and 6.9 indicate that the MSE backfill behind the abutment wall continued to stretch (expand, active state) during the first six months after opening the structure to traffic (from 0.5 to 1 year in the figure). The values of strains and movements experienced by the geogrid after bridge opening to traffic for three months (from 0.5 to 0.75 year from Jan 1, 1999) were almost close to those experienced during the previous construction stage. Possible cause for the straining of the geogrid during this period is traffic load. Figure 6.9 suggests that the first 12 mm of expansion movement of the MSE backfill (from 0 to around 0.75 years) occurs due to the presence of *compressible polystyrene layer between the bridge and the backfill.*

After 0.75 years from Jan 1, 1999, Figure 6.9 suggests that the MSE backfill experienced a cyclic lateral movement of 4 mm every year due to the seasonal changes in the temperatures of the superstructure. As the temperatures rise up every year during the warming season (defined before), the geogrid tensile strains decrease with time, and remained low around the summer time, suggesting that the MSE backfill is being compressed (passive state behavior). *This could be attributed to the expansion movements of the bridge superstructure (due to the continuous increase in air temperatures) that push the bridge abutment wall into the backfill behind the abutment wall.* As the temperatures fall down every year during the cooling season, the geogrid tensile strains increase with time, and remained high around the winter time, *suggesting that the MSE backfill is being stretched or expanded in the lateral direction (active state behavior).* *This could be attributed to the contraction movements of the bridge superstructure (due to the continuous decrease in air temperatures) that pull the abutment wall away from the MSE backfill.* Figure 6.9 suggests that the MSE backfill experienced a cyclic lateral movement of 4 mm every year due to the seasonal changes in the temperatures of the superstructure.

Figures 6.8 and 6.9 suggest an overall *continuous stretching of the MSE backfill over the five years of service, of approximately 1.5 to 2 mm every year. This behavior could lead to the settlement of the sleeper slab in the long-term and, if confirmed, should be minimized or prevented.* This response could be attributed to continuous shortening of the bridge or growth of the roadway. Continuous shortening of integral abutment bridges during years of service following construction was reported in the literature. Also, it is possible that this behavior is due to the continuous softening of the polystyrene sheets.

6.5.2 Horizontal Soil Pressure against the Abutment Back Wall

Three Geokon pressure cells, model 4810, were installed to measure the lateral earth pressures of the MSE abutment backfill (Figure 6.2). Gage 16H was inserted between the abutment wall and the polystyrene sheet near the bottom of the abutment wall, 1.5 m from the top of the soil layer. Gage 19HS was placed between the abutment wall and the backfill (the polystyrene was removed). Gage 19HN was placed against the polystyrene (between backfill and polystyrene). Gages 19HN and 19HS were placed 0.37 m below top surface of the soil layer.

Estimated active, at-rest, and passive lateral earth pressures at the level of gages assuming that polystyrene sheets are not placed and the backfill is not reinforced are listed in Table 6.1. The at-rest pressure corresponds to zero lateral strain in the soil. As the abutment backfill soil expanded in the lateral direction, the lateral earth pressure exerted by the backfill on the abutment wall decreases from the at-rest condition to a lowest active earth pressure value that corresponds to soil shear failure. As the abutment backfill soil compressed in the lateral direction by the abutment wall, the lateral earth pressure exerted by the abutment on the backfill increases from the at-rest condition to a highest passive earth pressure value that corresponds to soil shear failure.

Table 6.1. Estimated Active, At-Rest, and Passive Abutment Lateral Earth Pressures.

Gage #	Depth and Location	Active Earth Pressure (kPa)	At-Rest Earth Pressure (kPa)	Passive Earth Pressure (kPa)
16H	1.5 m, between abutment and polystyrene	7.2	12.3	153
19HN	0.37 m, between backfill and polystyrene, (against polystyrene)	1.8	3.1	38
19HS	0.37 m, between abutment and backfill (polystyrene was removed)	1.8	3.1	38

Part of the loads registered by Geokon hydraulic pressure cells placed against the abutment facing due to changes in temperatures are real stresses and some are not. The real stresses are owing to temperature effects on the soil and the structure (e.g., expansion of the bridge superstructure imposing horizontal earth pressure on the abutment backfill). For a confined hydraulic pressure cell, part of the measured stresses due to temperature changes are not real stresses that develop due to difference in the thermal and stiffness properties between the pressure cell and the surrounding environment. Several measures were taken to reduce the unreal stresses (see Abu-Hejleh et. al., 2000 for more details). Realistic measured lateral soil pressures behind the abutment wall are expected over a temperature range from 10 to 25°C (during late spring and early fall).

Time records for the measured lateral soil pressure results from the three gages during construction (completed 0.5 years from Jan 1, 1999) and after the bridge was placed into service are shown in Figures 6.10 and 6.11. Fluctuations in the measured pressure data are due to changes between day and night temperatures. The results suggests that the difference between the day and night measured horizontal earth pressures against the abutment wall can be as high as 15 kPa (Gage 16H), 25 kPa (Gage 19HN), and 35 kPa (Gage 19HS), respectively.

The graphical results indicate that in the overall the measured lateral earth pressure on the abutment wall are high around the summer time from June to August of every year (e.g., around 1.5, 2.5, 3.5, 4.5, and 5.5 years in the figures), decreased during the cooling season of every year, remained very small and negligible around the winter time (e.g., around 1, 2, 3, 4, and 5 years in the figures), and increased significantly during the warming season of every year. The significant seasonal and daily changes and large values in the measured lateral earth pressure on the abutment wall was not noticed in the measured lateral earth pressures on the front GRS below the bridge foundation. *Therefore, it can be concluded that the daily and seasonal fluctuations of air temperatures, causing the expansion and contraction movement of the bridge superstructure, are the primary cause for the fluctuation and large changes in the measured lateral earth pressures on the abutment wall.*

The results in Figures 6.9, 6.10, and 6.11 seem to suggest that the lateral earth pressure on the abutment wall was reduced to a round 2 kPa at all levels due to the compression of the polystyrene sheet (occurred at around 0.75 years from Jan. 1, 1999). This value is way below the active earth pressure estimated for Gage 16 H of 7.2 kPa (see Table 6.1). *Therefore, it can be concluded that the abutment MSE wall with flexible facing (due to presence of polystyrene sheets) allowed for mobilization of the friction resistance of the backfill and tensile resistance of the reinforcement, thus taking most of the lateral earth pressure load off the abutment facing.*

As the bridge abutment wall pulls away from the backfill behind abutment wall due to the contraction of the bridge superstructure, the contact between the abutment wall and soil reduces. This reduces significantly the measured lateral earth pressure against the abutment wall, even to zero when a void develops behind the abutment wall in the coldest times of the winter season (see Figures 6.10 and 6.11). On the low side of measured lateral earth pressures during the cold times, there is not noticeable difference between the measured data from Gages 19 HN and 19 HS, suggesting that voids would develop even without the placement of polystyrene sheets. *So low lateral active earth pressures should be expected due to presence of compressible polystyrene sheet even if the superstructure did not experience any contraction movement.*

The bridge abutment wall is pushed into the backfill behind abutment wall due to the expansion movements of the bridge superstructure. This led to exerting high lateral passive (or compression) earth pressure by the abutment wall on the reinforced soil mass as shown in Figures 6.10 and 6.11. The measured results of both geogrid tensile strains (Figure 6.8) and lateral earth pressures behind the abutment wall (Figures 6.10 and 6.11) indicate that the MSE backfill felt the thermal expansion of the bridge superstructure. *This suggests that the polystyrene placed behind the abutment wall and the reinforced fill either did not compress or “collapse” entirely to accommodate fully the expansion lateral movements of the bridge superstructure. However, Figure 6.11 indicates that the placement of polystyrene (gage 19HN compared with 19HS) reduced the maximum lateral earth pressures on the abutment wall by 10 kPa to 15 kPa. At depth of 1.5 m (Gage 16 H), the maximum measured lateral earth pressure behind the abutment wall was 20 kPa, way below the passive limit earth pressure of 135 kPa (Table 6.1). The measured lateral earth pressure from Gage 19HN was 35 kPa, very close to the corresponding passive earth pressure limit of 38 kPa. This means that the thermal expansion movements of the bridge superstructure will have significant influence on the upper zone of the abutment backfill but not the lower zone.*

6.5.3. Design Implications of the Measured Results

Design of the MSE abutment Backfill

- The design procedure significantly overestimates the loads carried by reinforcement behind the abutment wall by 3 to 4 times. This implies that the actual factor of safety against breakage and pullout failure of the reinforcement is 3 to 4 times higher than what is estimated in the design.
- The presence of compressible polystyrene sheets behind the abutment wall allowed for about 12 mm of free lateral expansion movement of the MSE backfill. This led to the mobilization of the friction resistance of the backfill and tensile resistance of the reinforcements in the MSE backfill, thus taking most of the lateral earth pressure load off the abutment facing. Therefore, it is very reasonable to assume in the design that the active

horizontal pressures exerted by the MSE backfill on the facing of the abutment wall as half of those calculated for the conventional retaining walls.

- Larger geogrid tensile strains and forces were experienced at location D beneath the sleeper slab (where traffic and approach slab loads are transferred to the soil mass) than at Location C. This finding suggests the location of the maximum tension line of the MSE system placed behind the abutment wall is located at or behind the back of the sleeper slab.
- An overall continuous stretching or expansion of the MSE backfill over the five years of service was noticed, of approximately 1.5 to 2 mm every year. *This behavior could lead to the settlement of the sleeper slab in the long-term and, if confirmed, should be minimized or prevented.* This response could be attributed to continuous shortening of the bridge or growth of the roadway (both reported in the literature). Also, it is possible that this behavior is due to the continuous softening of the polystyrene sheets.

Influence of Temperature Changes on Integral Abutments

The temperatures seem to rise up from March to May of every year (*warming season*), remain high around the summer time of every year from June to August, decrease from September to November of every year (*cooling season*), and remain low around the winter time from December to February. During the warm days and seasons, the Founders/Meadows superstructure expands, pushing the abutment into the backfill. During the cold days and seasons, the superstructure contracts, pulling the abutment away from the backfill. This led to the continuous cyclic lateral movements of the abutment wall with time (estimated at 4 mm). *It was concluded that the daily and seasonal fluctuations of air temperatures, causing the expansion and contraction movement of the bridge superstructure, are the primary cause for the fluctuation, cyclic, and large changes in the measured lateral earth pressures on the abutment wall and lateral movements of the abutment MSE backfill (and possibly the approach slab).*

- Each year, the bridge abutment wall pulls away from the backfill due to the contraction movements of the bridge superstructure during the cooling and winter times. This lead to the expansion of the MSE backfill (increase in the reinforcement tensile strains) and reduction of the lateral earth pressures on the abutment wall, even to zero when a void develops between

the backfill and the abutment wall during the coldest time of the winter season. Voids would develop between the MSE backfill and the abutment wall during the cold seasons and nights, with or without the presence of polystyrene sheets.

- ❑ Tensile strains should be expected in the approach slab during the colder nights and seasons of the year and should be designed accordingly to prevent creation of tension cracks.
- ❑ Each year, the bridge abutment wall is pushed into the backfill due to the expansion movements of the bridge superstructure during the warming and summer times. This lead to exerting high lateral passive earth pressure (or compression lateral strains) by the abutment wall on the reinforced soil mass (the MSE backfill felt the thermal expansion movement of the bridge superstructure).
- ❑ The presence of compressible polystyrene sheets accommodate to a large extent (but not entirely) the expansion thermal movement of the bridge superstructure.
 - The expansion lateral movements of the MSE fill due to the seasonal changes in temperatures were estimated around 4 mm. This is much less than the expected expansion lateral movement of the bridge superstructure of 100 mm.
 - At a depth of 1.35 m, Hoppe and Gomez (1996) reported a maximum passive earth pressure of 175 kPa behind an integral abutment where polystyrene sheet was not used and he backfill was not reinforced. At depth of 1.5 m, the maximum measured lateral earth pressure behind the abutment wall of the Founders/Meadows structure was 20 kPa, way below the limit passive earth pressure of 135 kPa.
 - In the upper zone of the abutment wall, although the presence of polystyrene reduced the lateral passive pressures by 10 kPa to 15 kPa, high passive lateral earth pressures of 35 kPa were exerted by the abutment on the MSE backfill. This means that the thermal expansion movements of the bridge superstructure will have significant influence on the upper zone of the abutment backfill during the summer time. This could lead to the fill settlement problem and should be avoided in the future. In the upper zone, it is recommended to use softer (less dense) from of polystyrene sheet.
- ❑ For the MSE abutment backfill systems as in the Founders/Meadows structure, the bridge abutment wall can designed safely for a relatively low and uniform passive earth pressure of 35 kPa (exerted during the summer time), not the passive earth pressure estimated for

conventional retaining walls with rigid facing and unreinforced soil backfill. The difference between the day and night measured horizontal earth pressures against the abutment wall can be as high as 25 kPa.

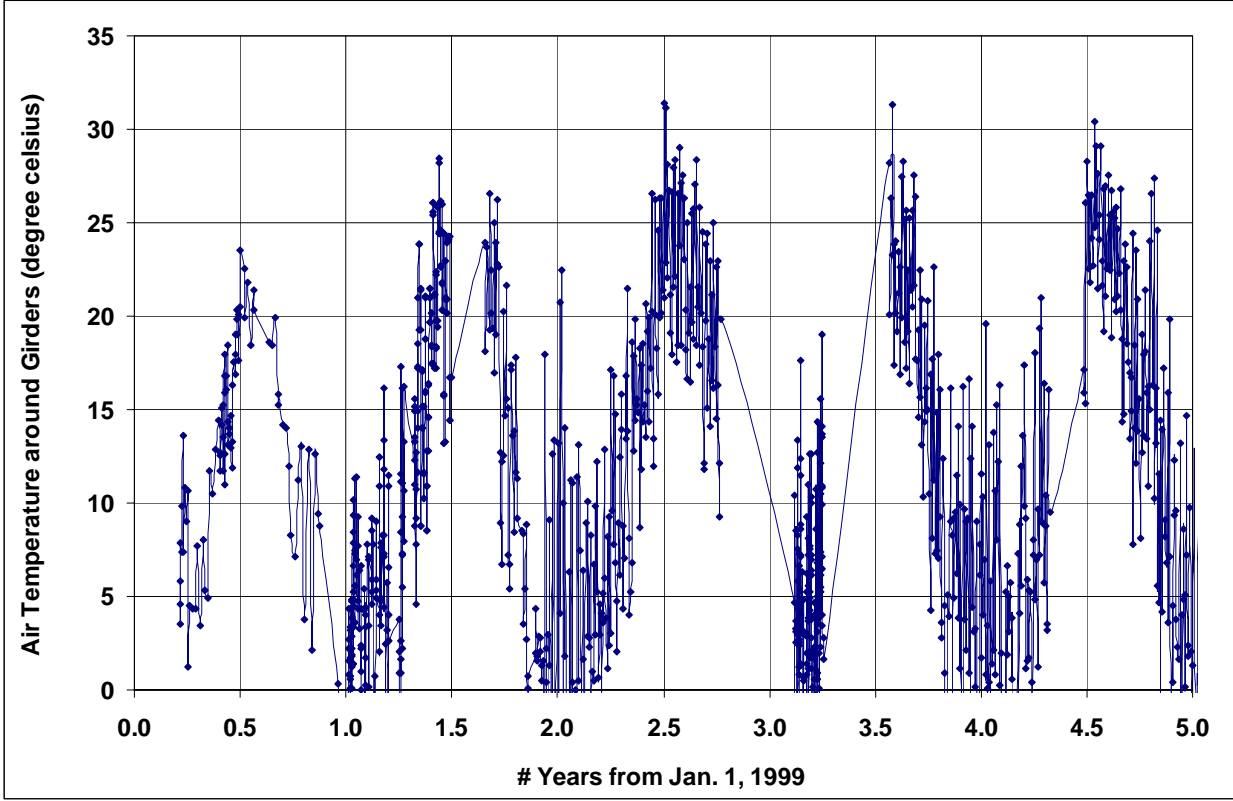

Figure 6.7. Measured Air Temperatures below Girders of the Founders/Meadows Structure.

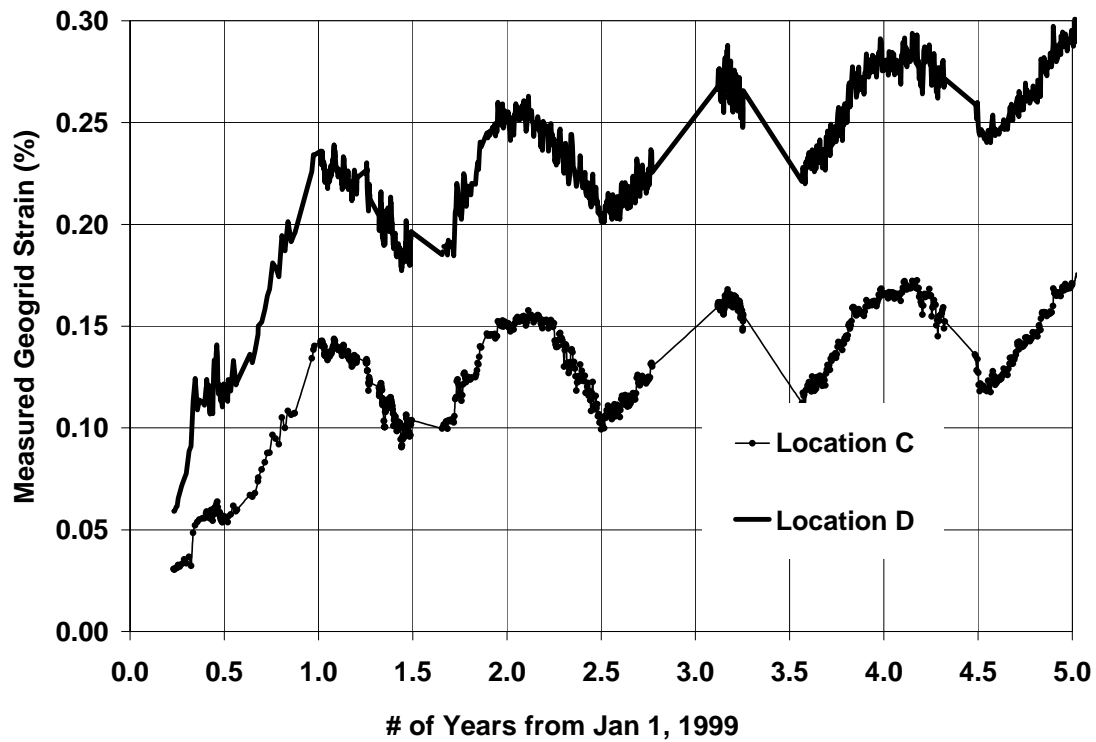

Figure 6.8. Measured Geogrid Tensile Strains at Various Times from Gages Placed in the MSE Abutment Backfill Behind the Abutment Wall as Shown in Figure 6.2 (Construction was completed 0.5 year from Jan. 1, 1999).

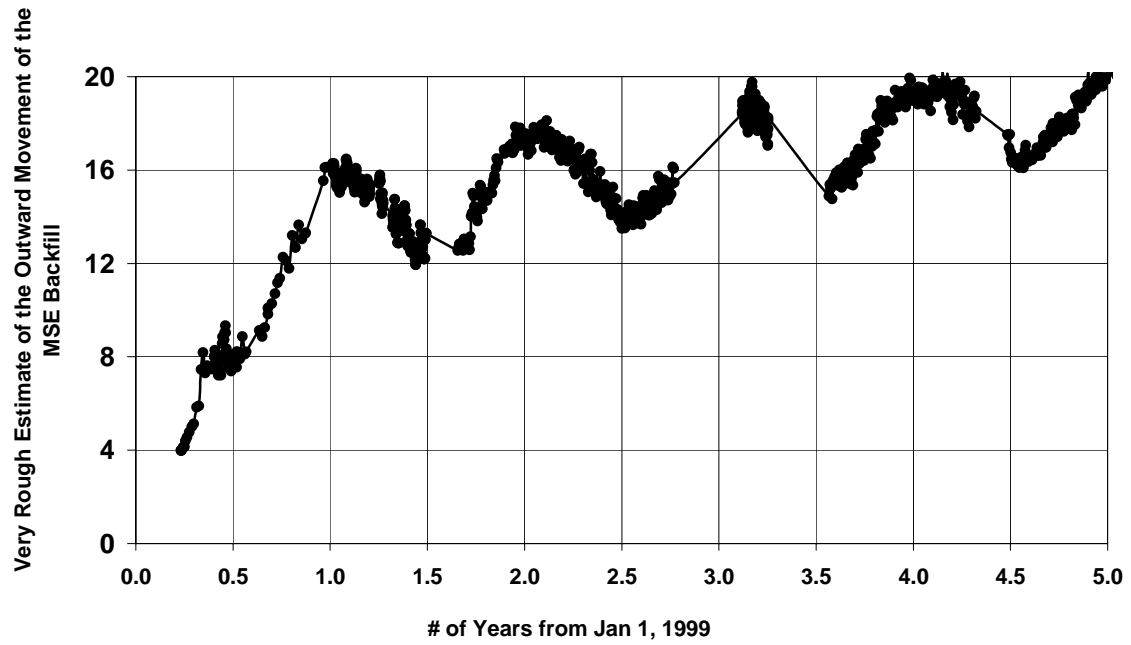

Figure 6.9. Rough Estimate of the Expansion Lateral Movements of the MSE Abutment Backfill during Various Times (Construction was completed 0.5 year from Jan. 1, 1999).

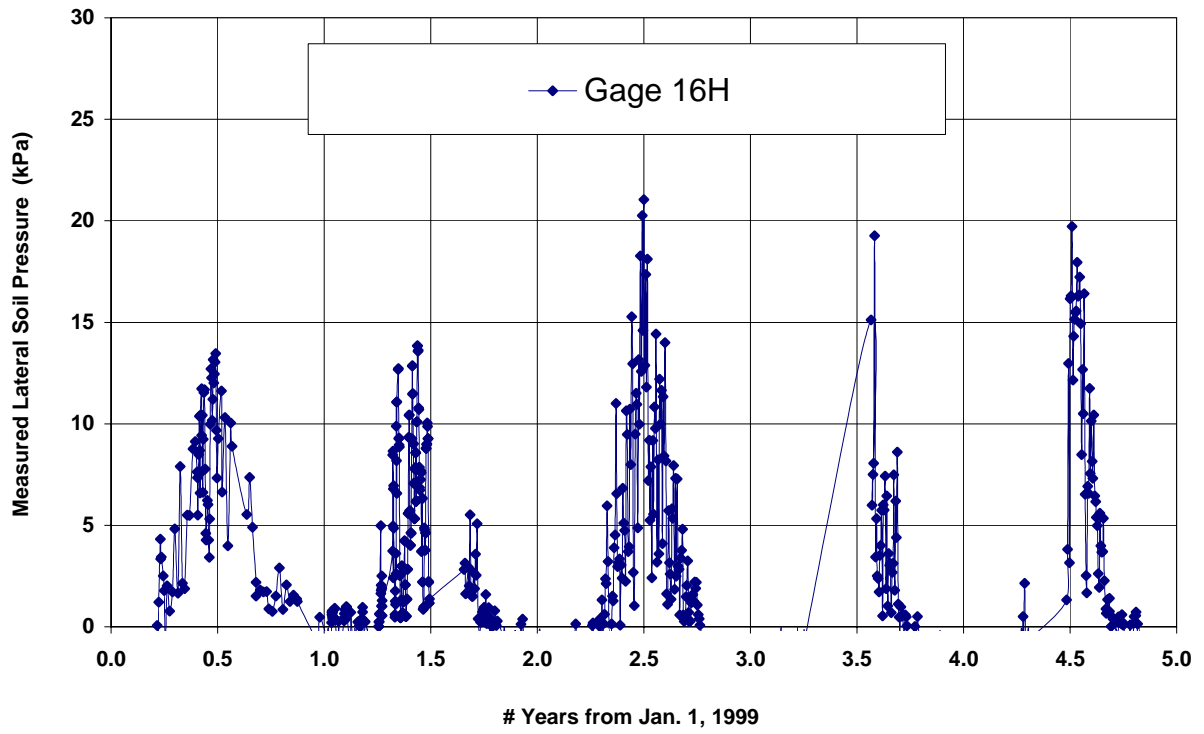

Figure 6.10. Measured Lateral Earth Pressure Against the Lower Portion of the Abutment Wall of the Founders/Meadows Bridge (see Figure 6.2) during Various Times.

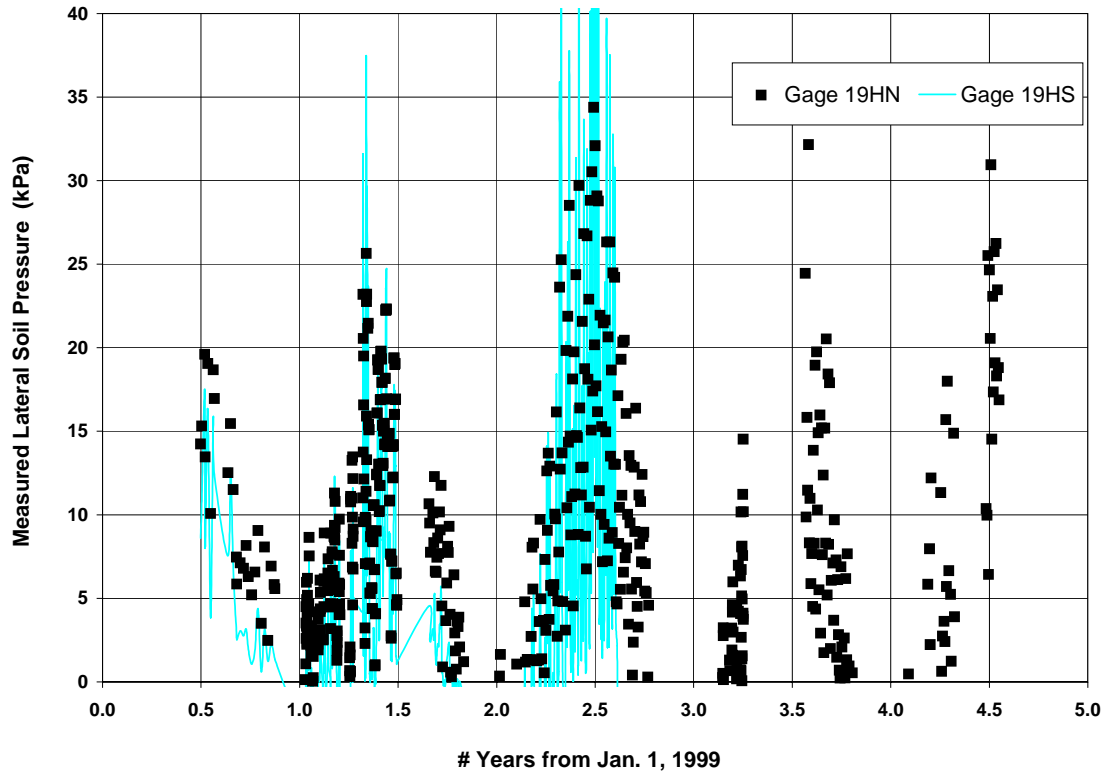

Figure 6.11. Measured Lateral Earth Pressure Against the Top Portion of the Abutment Wall of the Founders/Meadows Bridge (see Figure 6.2) during Various Times.

7. SUMMARY, STUDY FINDINGS AND RECOMMENDATIONS

7.1 Overview

Bridge approach bumps cause uncomfortable rides and can make it difficult to remove water from the roadway and structure. These problems create hazardous driving conditions, especially in the winter season, and require costly repairs with unnecessary traffic delays. Before 1992, the Colorado Department of Transportation's (CDOT's) measures to alleviate the bridge bump problem included the extension of wing walls along the roadway shoulder, and use of approach slab and granular backfill (Class I Structural Backfill) behind the abutments. The approach slab is supported by the bridge abutment wall at one end and a sleeper slab foundation at the roadway end. The concept of using of an approach slab is to provide a gradual distribution of the approach settlement and a smoother transition between the bridge and approaching roadway. However, the occurrence of the bridge bump problem through an abrupt change in grade at the sleeper slab has been observed at several sites. Since 1992, CDOT has implemented several additional improvements to construction of bridge approaches to alleviate the bridge approach bump problem. Four new systems for construction of bridge approaches have been implemented and were evaluated in this study:

A. Flowfill Bridge Approaches. In November 1992, CDOT began using flowfill backfill (a low-strength concrete mix) behind the abutment wall in an effort to reduce the approach settlements. The self-leveling ability of flowfill allows it to flow, so no compaction is needed, and fill voids and hard-to-reach-zones. Also, it experiences negligible settlements after curing. A total of 110 bridges were constructed with flowfill abutment backfill from 1993 to 2001 (none could be found in 2002 and 2003). Given the relatively high cost of flowfill (\$76 per cubic yard in 2005) relative to conventional embankment material, the performance of existing installations was studied to determine if this practice is worth continuing.

B. MSE Class 1 Backfill Bridge Approaches. The use of mechanically stabilized earth (MSE) Class-1 backfill behind abutment walls as a lower cost alternative (\$37 /CY in 2005) compared to flowfill has been a growing practice in Colorado. Standard details for MSE abutment Class-1 backfill were introduced in CDOT on May 21, 2000. A total of 14 bridges were constructed with

MSE Class 1 Backfill between 1999 and 2003 (none before 1999). Most of the reinforcements in the MSE embankments are geofabric wrapped around the back face of the abutment, but geogrid (stiffer) reinforcements are considered in some situations to stiffen the backfill and further reduce the approach settlements. The reinforced fill behind the abutment is used to build a vertical, self-contained wall capable of holding an approximately vertical shape and forming an air gap between the abutment and retained fill. By installing geofabric/geogrid tensile reinforcements in the fill, it becomes stiffer and stronger. However, no field performance records were available for CDOT MSE approaches with Class-1 Backfill prior to this study.

C. MSE Class B (Porous) Backfill Bridge Approaches. In the last few years, Class B filter material has replaced the Class-1 Backfill in construction of 10 new MSE backfill bridges (cost \$57/CY in 2005). Class B filter material was selected because it is more free draining, is less susceptible to wetting induced softening/collapse, less erodible, has less fines for clogging drainage systems, and requires less compaction effort compared to Class-1 Backfill. Although these engineering properties are superior, performance information of the system was still needed.

D. GRS Abutment System. The Founders/Meadows bridge structure was constructed in 1999 near Denver, Colorado using geosynthetic-reinforced soil (GRS) walls to provide the support for shallow foundations of the two-span bridge and the approaching roadway structures (note that this is in contrast to Systems A, B, and C described above where deep foundations supported the bridge abutment). The approaching roadway embankment and the bridge footing were integrated at this site with an extended reinforced soil zone to minimize/alleviate the uneven settlements between the bridge abutment and approaching roadway. This structure is considered experimental, and its approaches were instrumented during construction with moisture gauges, strain gages, and pressure cells and profilometer tests were conducted to evaluate the smoothness of the approaches. Field measurements were collected periodically from beginning of construction through five years of service. This report summarizes the data and the lessons that are learned from this unique structure.

But the occurrence of significant settlement at the sleeper slab in flowfill and MSE approaches

still occurs, causing an abrupt change in elevation grade at the sleeper slab, resulting in high repair costs. Performance information on the recent systems and measures employed by CDOT to alleviate bridge bump the problem are needed. In particular, the causes and sources of the approach settlement problem in Colorado bridges must be identified so that best practices can be implemented. This study was proposed to address all these needs.

The objective of this study is to provide recommendations to improve CDOT's current practice for construction of bridge approaches (improve performance and reduce costs). Several tasks were performed to meet this objective:

1. *Summarize CDOT's current practice that has evolved since 1993 the for the geotechnical investigation, construction, and repair of bridge approaches and the comments and suggestions collected from CDOT Staff and reported in the literature to improve this practice (see Chapter 2 and Appendix A).* The current typical CDOT bridge approach system includes a foundation soil layer where subsurface geotechnical investigation is performed followed by performing settlement analysis, an embankment fill soil layer placed on top of the foundation soil layer, a high quality backfill material (flowfill or MSE Backfill) placed behind the abutment wall and beneath the approach and sleeper slabs (described before), surface and internal drainage systems, and expansion joint device typically placed on top of the sleeper slab.

2. *Provide detailed descriptions of all possible causes of the bridge approach settlement problem at the sleeper slab and the information needed in a forensic investigation to identify the causes and sources of this problem and determine if the settlement problem has more or less ended or if significant settlement potential remains in the future (see Chapter 3).* The primary causes include: (1) compression and creep movements of the fill and foundation soil materials (due to compressible soil layers, and applied static and dynamic loads); (2) thermal movements of the bridge superstructure (of more concern with integral abutments); (3) lateral movement of side walls (MSE walls must laterally move to mobilize the tensile resistance of the reinforcement layers); (4) problems in the geotechnical investigation; (5) problems encountered during construction; and (6) inadequate performance of the expansion joints and the drainage systems. In addition, detailed description of the influence of moisture and temperature on soil settlements is presented. Key information identified to improve forensic investigations and documentation

include: (1) design, materials, and construction records of the bridge approach structure; (2) level, location, and time progression of the settlement problem; and (3) information from a comprehensive subsurface geotechnical investigation. Chapters 3, 4 and 5 present the detailed procedures to collect and analyze this information for bridge approaches that have experienced approach settlement problems.

3. *Evaluate and compare the field performance and cost-effectiveness of bridge approaches constructed by CDOT with flowfill and MSE backfill materials (see Chapter 4, Appendices B and C).* Performance of side by side flowfill and MSE bridge approaches is presented for two bridges in Region 4. A procedure was developed and applied to evaluate the performance of MSE and flowfill bridge approaches, and estimate the total unit cost (construction and repair) needed to maintain acceptable performance of these approaches over their entire service life. The performance and cost information were obtained from records collected by the CDOT Bridge Management Section, input from CDOT's Regional Maintenance Offices, and field visits, and from information published by the CDOT Engineering Estimates & Market Analysis Unit. Performance ratings for bridge approaches reflected the range of settlement experienced by the bridge approaches at the sleeper slab and the traffic speed (significant to moderate to slight bump problems).

4. *Conduct a forensic investigation (including short- and long-term settlement analyses) on the MSE and flowfill bridge approaches that experienced significant settlement problems.* The purpose was to determine the causes and sources of the current settlement problems and if this settlement has more or less ended or if settlement potential remains in the future (see Chapter 5 and Appendix C). This information is needed to develop an effective plan for repair and mitigation of the settlement problem. The investigation was performed on five bridge structures, with three thoroughly investigated per the guidelines presented in Task 2.

5. *Compile and analyze the data collected over five years on the performance and design assessment of the measures employed in the Founders/Meadows Bridge to alleviate the bridge bump problem (see Chapter 6).* Analysis of these performance data also provides insight into the

behavior and validity of some of the design assumptions for MSE and Flowfill bridge approaches.

6. *Based on the results of previous tasks summarize the study findings and the recommendations learned to improve CDOT current practice for bridge approaches. These results are presented in the next section.*

7.2 Study Findings

7.2.1 CDOT's Current Practice for Bridge Approaches and Reported Suggestions for Improvements

General:

- At several locations the calculated bridge camber does not work out correctly, leads to water accumulation at the abutments and in many instances the pier locations as well. Where present, drains located on the bridge near the abutment reduce the standing water problem at the bridge ends that contribute to the approach settlement problem.
- The best bridge approaches are those constructed decades ago (1950-1970) because construction timing was longer, allowing for more settlement and densification of the foundation and fill soil, and better deck surface drainage systems were installed to keep water away from the approach slab.
- Cast-in-place (CIP) reinforced concrete wing walls seem to perform better than MSE walls.

Fill Soils

- CDOT construction specifications require that frozen materials not be used in construction of embankment and fill, but this is not enforced in some cases.
- Both granular and fine-grained soils (fill and foundation soils) can experience settlements under an increase of their moisture contents and temperatures (if initially frozen). Such settlements will cease or be reduced significantly once the soil moisture has reached an equilibrium condition. Therefore, for fill soils with potential for softening/collapse and even

swelling/shrinkage as a result of changes in moisture content, it is often recommended in the literature to compact the soil wet of the optimum or even to soak the soil with water.

- Compression of granular soils upon wetting occurs and can be especially problematic when the fill is placed on the dry side of the optimum. The problem is worse if the soil is not well compacted. For granular soils, CDOT current specifications do not provide any guidelines on the placed water content relative to the optimum (such guidelines are provided only for the fine-grained soils).
- Class 1 Backfill prices depend on location (cost is relatively low in the eastern part of the state).
- Several project engineers recommended adding vibration of the flowfill to the construction specification to better consolidate the material and force out excess water. The end result is stiffened flowfill and a much faster set time. Vibration-induced settlement of 2 inches has been observed, which should help to alleviate the bridge bump problem.
- Construction personnel complained of the lack of compaction quality assurance methods for placement of the Class B filter material.
- The magnitude and timing of settlement of clayey embankment fill materials placed beneath the sleeper slab are not computed in the design phase. However, it is often reported that the wall's granular backfill consolidates during and after construction and this settlement is related to the depth of the fill, the degree of compaction, the moisture content, and type of fill. Settlement of properly compacted backfill material is roughly estimated to be 1% of the total fill height. The study found that this approximation is on the conservative side.

Approach slab

- Several CDOT personnel recommended increasing the support for the sleeper slab by: (1) consider a stiffer/higher capacity foundation system for the sleeper slab (e.g. driven piles); or (2) use thicker layers of flowfill and MSE backfill beneath the sleeper slab.
- NCHRP synthesis report (1997) indicates that a change in the slope of the approach slab of 1/200 is tolerable and for an approach longer than 15 ft, this corresponds to a settlement at the expansion joint (or sleeper slab) of 0.9”.

- NCHRP 234 report recommended offsetting (i.e. pre-cambering) the design elevation of the sleeper slab by 1 inch (or value less $1/200$ of the approach slab length) to compensate for the anticipated post-construction settlements. Some CDOT engineers believe that building the end of the approach slab high (since the fill seems to never be higher than the bridge) could be a suitable measure to mitigate the bridge bump problem. However, this requires a suitable analysis method to estimate settlements of the sleeper slab and may require additional monitoring of such structures in the future.

Expansion Joints

- Closed expansion joints are encountered in Colorado bridges even during the winter time. There is some evidence that the concrete roadway creeps and expands with time. This may be the cause of this closure.
- When expansion joints are placed on top of the sleeper slabs, cracking and crushing of the approach slab concrete may occur due to the closure of the expansion joints and dragging of the approach slab (note that contraction of approach slab is restrained by ground friction). Cracks are often noticed near to the expansion joint. These cracks facilitate the infiltration of water to the fill under the sleeper and approach slab.
- Important lessons learned from NCHRP Synthesis 319 project: (1) Most bridge owners favored the premolded strip seal joints for short-to-moderate spans. This type of joint is best used when the movement rating is beyond the capacity of compression seal and for larger skewes. (2) For longer spans, the preferred joints were the finger joint and the modular system joint. For those who give cost a high priority, the finger joint (open joint) was preferred, with a trough to collect material passing through the opening. For those who demanded water tightness, the modular system was the choice.

Drainage Details

- It is a standard in CDOT guidelines to place impervious membrane with collector pipes at the top of the MSE wall, but it is not standard for MSE approaches.

- In many field sites, no water coming from the drainage pipes was observed, which is indicative of problems with the drainage system. In many locations, the wall's drainage pipes were observed to be clogged.

Repair Methods for Bridge Approaches

- It is very costly and inconvenient to the traveling public to completely remove the approach slab, reconstruct the embankment at the approach, then replace the slab. Other repair methods (described in Chapter 2) are much more cost-effective.
- Bridge approaches that are covered with asphalt allow for cost effective repairs compared to reinforced concrete approaches. Eliminating the approach slab altogether would make any future repair of the approaches potentially more cost effective.
- When MSE wall is employed to construct wing walls, the soil stabilization techniques (pressure grouting or the Uretack Method) may not work because of the lack of lateral confinement (block face units push outward).
- Two bridge approaches were repaired using deep foundation: Structure E-17-PQ with driven piles and the 58th avenue with drilled shafts. They were both inspected and found to be functioning satisfactorily.

7.2.2 Causes of the Bridge Approach Settlement Problem in Colorado

The bridge bump problem is correlated mainly with the presence of high fills and often occurs where widening occurred. This is the new added fill on top of the original ground level. The problem is of more concern for new bridge locations than for site where replacement of an old bridge occurs. In a few structures, the problem was noticed in the side where the flowline is located.

It was noticed that most of the problematic bridge approaches occurred in the north central and north east zones of Region 6 (Along I-76 around and north of the I-70/I-25/SH36 Intersections) where the traffic load is high and soft foundation conditions are present.

Sources of the settlements. The sleeper slab, where settlements occur, is only supported by 4 ft of high quality flowfill or MSE backfill material, so the main sources of these settlements are the embankment fill and foundation soil layers. For large embankment fills and soft foundation conditions, the contribution of the 4 ft backfill placed beneath the sleeper slab to the approach settlement is minimal. This finding suggests the type of the abutment backfill (flowfill vs. MSE Class 1 backfill) should not have significant influence on the performance. The performance results presented in next section support this finding. Note that most of the high quality backfill is placed under the approach slab which does not transmit significant load to the underlying backfill (see Figures A.1 to A.2.).

Causes of the Settlement Problem

Drainage Problems. Failure of the installed drainage systems to keep the surface and ground water from reaching the fill and foundation soil layers is a common factor in almost all the bridge approaches that experienced settlement problems. It is very common for water to infiltrate into the embankment fill at the expansion joint and cracks. The infiltration of water can have different degrees of effect on reducing strength and increasing deformability of the embankment materials located under the sleeper slab. Water from surface runoff can wash out the embankment material creating voids underneath the approach and roadway slabs.

A bump at End of Construction. The elevation grades of the as built bridge and roadway approaches do not exactly match the design elevations creating a built-in bump at the end of construction (observed in Regions 2 and 6). The problem is worsened if the expansion joint is placed per the design grades not based on grades of the constructed bridge and approaching roadways.

Construction Problems of the Placed Abutment and Embankment Fill Materials. Most of the documented CDOT bridge approach settlement problems occur shortly after construction (within one year after accepting a new project) and sometimes during construction before the project is accepted. Construction problems of the placed fill material are the main causes of such “quick” settlement problems. Settlements of the placed fill materials during or shortly after construction is completed can be attributed to:

- Inadequate compaction of the fill. It is also difficult and hard to construct firm and well compacted slope sides for the embankment fill.
- Construction during the cold season leading to frozen fill (construction timing) and low compaction.
- Placement of compacted fill soils (especially granular) on the dry side leading to compression of the soil upon wetting.
- Softening of the fill soils (especially fine-grained soil) due to infiltration of surface water and accumulation in certain zones that become very soft-like slurry. This softening seems to occur at the interface between a granular soil layer and the underlying fine-grained soil layer.
- At one site, it was observed that the flowfill was not uniform and low quality. It is also possible that water penetrated the flowfill around the sleeper slab and degraded it.

Settlements of the Foundation Soil Layer

- Presence of a compressible clay foundation soil layer that may not be detected or adequately addressed during the subsurface investigation.
- Placement of a high fill load above the original ground level.
- Softening of the foundation soil layer due to either infiltration of surface water or rise of the GWT. If the top of the foundation soil layer is dried, CDOT project personnel may think it is firm enough and meet CDOT construction specifications. A subsurface geotechnical investigation may also show that that this layer is stiff if it was performed during the dry or the very cold season. Accumulation of water on the top of a foundation soil layer may soften it even if it is well compacted but will significantly soften it if it is dried and not well compacted. In other words, water can easily soften a soil material that derives its strength from desiccation, not from a mechanical compaction.

Salt Creek Bridge (SH 50, Pueblo). Settlement was attributed to the presence of loose fill soil (main reason), and presence of a slightly compressible sandy lean clay layer that supported high fill loads (up to 25 ft), lateral displacement of the upper MSE wall, and failure of the drainage

measures. The non-uniformity of the applied fill loads resulted in the observed differential settlement pattern across the approaches.

I-70/I-225 Bridge Approaches. Settlement appears to have been caused by poorly compacted class 2 structural backfill that was not compacted as required per CDOT construction specifications. In this backfill, a very soft (almost like slurry) clayey soil layer with high water content was found at a depth of 17 to 23 ft from top of the wall. It is unlikely that this layer was placed in this form during construction. Most likely, the surface water infiltrated the backfill and softened this zone. The variation in the longitudinal and transverse stiffness of the foundation systems resulted in the observed differential settlements pattern along and across the approaches.

SH 287 Bridge Approaches. Settlement is attributed to the presence of very soft clay soil layer that was not indicated in the foundation report, possibly because the geotechnical investigation and construction were performed when the top part of the foundation cohesive soil layer was desiccated under surface drying. Then, after construction was completed, surface water infiltrated through the permeable embankment material, accumulated on top of foundation soil layer, and softened it. It is also possible that softening of foundation clay layer resulted from the rise of the GWT which is located at a relatively shallow depth.

Structure E-19-Z Approaches (US 36, East of Bennett). The embankment was constructed during the winter months (the fill was frozen) and maintenance personnel observed sudden and rapid settlement of the newly constructed embankment once the ground thawed in late spring. Continued settlement has occurred due to loss of fines via water intrusion into the embankment and the probable breakdown of intact claystone nodules found in the fill. This has occurred at the sleeper slab expansion joints and at the asphalt cutouts near the wing walls where water has flowed into and under the approach and sleeper slabs.

Structure E-17-PR Approaches (I-76 @ 136 Ave). The lab results showed very soft and excessive moist embankment material at the SE bridge approach that gets stiffer and drier with depth. This indicates infiltration of water from the surface into the embankment materials. The combination of excessive moisture in the embankment and repetitive traffic loading induce

settlement of the embankment material. Localized erosion underneath the slab at the SE wing wall area was observed during the site investigation. Erosion of the embankment material will lead to further settlement of the approach and roadway slabs.

7.2.3 Performance of Different Systems Employed for Construction of Bridge Approaches

Performance and Cost-Effectiveness Analyses of Flowfill and MSE Approaches. In these analyses, a total of 98 bridges were constructed with flowfill backfill material (202 approaches), 14 with MSE Class 1 backfill (28 approaches), and 10 with MSE Class B Backfill (20 approaches). A list of these bridges and detailed performance results for each structure are given in Tables B.4 through Table B.7. Performance results for these approaches are briefly summarized in Table 4.5. Results of the cost-effectiveness analysis are summarized in Table 4.6. *The performance and cost-effectiveness data presented in Tables 4.5 and 6 are based on limited number of data and service years for MSE approaches and therefore should be considered with precaution. In addition, the performance and repair of approaches are not only controlled by abutment backfill but more related to drainage, construction workmanship, embankment, and foundation soil, as discussed before. Findings are*

- ❑ Most of the flowfill and MSE bridge approaches constructed by CDOT since 1993 are performing well, with no settlement or cracking problems.

- ❑ Most of the settlement problems for the flowfill approaches occurred with the older bridge approaches constructed in 1994 when CDOT initiated flowfill operations. The 2005 unit construction cost for flowfill is \$76/CY. The estimated total 2005 unit cost of flowfill approaches over their service life of 40 years ranges from \$95/CY if no additional repair costs will not be needed in the future to \$176/CY if repair will be needed in the future (assuming that past and future repair rates are identical). If flowfill approaches constructed before 1994 were not considered in the cost-effectiveness analysis, the unit cost of the flowfill over the entire design life would drop to around \$80/CY. This suggests that that the costly flowfill backfill should remain a viable alternative in special applications because it has outstanding performance.

❑ Out of 28 bridge approaches constructed with MSE Class-1 backfill, 4 approaches at two bridge structures failed. Pure construction problems caused the failure of the MSE approaches that could be avoided in the future with better and tighter construction specifications for the backfill and embankment materials. These failures would not be eliminated if flowfill backfill was employed because the primary sources of the settlement problem were the embankment and foundation soils, not the 4-ft thick backfill placed beneath the sleeper slab. However, it is possible that the extent of these failures would be reduced with flowfill because construction problems in MSE backfill, like lack of compaction or construction timing, will not be of concern with flowfill. Generally, MSE backfill is more sensitive to construction problems than flowfill.

❑ The use of MSE Class 1 backfill is cost effective ONLY if the rate of repair of MSE approaches will decline significantly in the future. In this case, the unit cost of MSE approaches over the entire service life would be much less than that for flowfill and comparable to approaches constructed with MSE Class B. However, if the past rate of repair continues in the future, the unit cost will be much higher because: 1) the repair costs of the four failed MSE Class-1 Backfill approaches were significant; 2) the limited number of constructed MSE approaches; 3) and the relatively short service period of MSE approaches.

❑ The MSE Class B filter material as abutment backfill has the lowest cost. This is because no repair was reported for the MSE Class B approaches and their current performance is adequate. A more scientific evaluation on the performance and cost-effectiveness of the MSE Class B Backfill material should be made after five or 10 years when both number and average service life of MSE Class B approaches have increased.

Performance of the Founders/Meadows MSE Approaches (Integral Abutment)

● The overall short- and long-term performance of the approaches of the Founders/Meadows structure is excellent because there is no evidence of the “bump at the bridge” problem after five years in service, and there are no signs of structural distress to the approach slab and the bridge expansion device.

Drainage measures included placement of impervious membranes with collector pipes at the top of the MSE backfill beneath the approach slab (was not extended beneath the sleeper slab) and a wick drain filtration and collection system at the interface of the backfill and the existing ground.

- The placed drainage protection system was not fully effective in preventing surface water from reaching deep inside the reinforced soil mass. The backfill beneath the sleeper slab becomes fully saturated during late June of each year. There are signs of gradual softening of the soil beneath the sleeper slab with time due to increase of retained soil moisture.
- The design procedure significantly overestimates the loads carried by reinforcement behind the abutment wall by 3 to 4 times. This implies that the actual factor of safety against breakage and pullout failure of the reinforcement is 3 to 4 times higher than what is estimated in the design.
- The largest measured horizontal geogrid tensile strains were experienced around the sleeper slab location (where traffic and approach slab loads are transferred to the soil mass).
 - An overall continuous stretching or expansion of the MSE backfill over the five years of service was noticed, of approximately 1.5 to 2 mm every year. This behavior could lead to the settlement of the sleeper slab in the long-term and, if confirmed, should be minimized or prevented. This response could be attributed to continuous shortening of the bridge or growth of the roadway (both reported in the literature). Also, it is possible that this behavior is due to the continuous softening of the polystyrene sheets.

A compressible 75 mm thick low-density expanded polystyrene sheet was placed between the reinforced backfill and the abutment walls to accommodate the horizontal expansion movements of the bridge superstructure without affecting the backfill (reduce passive earth pressures) and allow for the free expansion of the MSE backfill (reduce active lateral earth pressures).

- The presence of polystyrene sheets behind the abutment wall allowed for about 12 mm of free lateral expansion movement of the MSE backfill. This led to the mobilization of the friction resistance of the backfill and tensile resistance of the reinforcements in the MSE backfill, thus taking most of the lateral earth pressure load off the abutment facing.

Temperatures rise from March or May (*warming season*), remain high around the summer time from June to August, decrease from September to November (*cooling season*), and remain low around the winter time from December to February.

- Each year, the bridge abutment wall pulls away from the backfill due to thermal contraction movements of the bridge superstructure during the cooling and winter times. This leads to the expansion of the MSE backfill (increase in the reinforcement tensile strains) and reduction of the lateral earth pressures on the abutment wall, even to zero when a void develops between the backfill and the abutment wall during the coldest time of the winter season.
- Tensile horizontal strains should be expected in the approach slab during the colder nights and seasons of the year.
- Each year, the bridge abutment wall is pushed into the backfill due to the expansion movements of the bridge superstructure during the warming and summer times. This lead to exerting high lateral passive earth pressure (or compression lateral strains) by the abutment wall on the reinforced soil mass (the MSE backfill felt the thermal expansion movement of the bridge superstructure).
- The presence of compressible polystyrene sheets accommodate to a large extent (but not entirely) the expansion thermal movement of the bridge superstructure.
 - The expansion lateral movements of the MSE fill due to the seasonal changes in temperatures were estimated around 4 mm. This is much less than the expected expansion lateral movement of the bridge superstructure of 100 mm.
 - The measured passive lateral earth pressures were below those reported for integral abutments where polystyrene sheet was not used and the backfill was not reinforced.
 - In the upper zone of the abutment wall, although the presence of polystyrene reduced the lateral passive pressures by 10 kPa to 15 kPa, high passive lateral earth pressures of 35 kPa were exerted by the abutment on the MSE backfill. This indicates that the thermal expansion movements of the bridge superstructure would have significant influence on the upper zone of the abutment backfill during the summer time. This could lead to the fill settlement problem and should be avoided in the future.

7.3 Recommendations

These recommendations are valid for CDOT current practice for geotechnical investigation, construction, and repair of bridge approaches as presented in Chapter 2.

7.3.1 Systems for Construction of Bridge Approaches

□ Recommended that CDOT uses the lower cost MSE approaches with both Class B and Class 1 backfill materials in its future projects over the next few years and monitor and document the performance and repair of these structures. The QA procedure for the placed backfill material should be tightened and improved as suggested later. After a few years, when both number and average service life of MSE approaches are increased, an investigation such as the one performed in this study should be conducted to evaluate the performance and cost-effectiveness of various abutment backfill materials (flowfill, MSE class-1, MSE Class B) and decide if CDOT should reconsider the use of flowfill on a standard basis.

□ Flowfill should remain a viable alternative for certain field and construction scenarios although it is more costly. Flowfill is recommended in certain difficult field conditions (e.g., to fill and close up voids, in areas where compaction is difficult, easier to place around an embankment slope). In phased construction of MSE abutment backfill, heavy compaction may cause stability problems for the phase 1 portion. Other types of soil fill materials are not as quick or as easy to construct as flowfill. Consequently flowfill should remain an option for projects where these advantages warrant the additional costs (e.g., fast track construction projects, in critical highways, where the excavation presents a deep awkward hole to fill in a minimum amount of time).

□ The use of the MSE or GRS abutment system should be considered by CDOT design engineers as a viable alternative in future bridge abutment projects- it is the best system to alleviate the approach bridge bump problem. All the details for implementation of the GRS abutment were developed under a different study (Abu-Hejleh et. al., 2001). A recently completed NCHRP project (12-59) provides more details for using the MSE Abutment System.

7.3.2 General Recommendations

- Require a warranty by the contractor for bridge approaches in the first year of service. The one year or 18 month warranty period is recommended because the settlement problems seem to occur immediately after accepting a new project (within one year in most cases) and sometimes during construction before the project is accepted.
- Consider CIP reinforced concrete wing walls in the approach areas (not MSE wall with block facing) to provide the confinement needed if soil stabilization techniques are needed later to raise the slab and repair the approaches.
- If it is estimated that the settlement of the sleeper slab would continue for a long time and would be significant (due to the present of fat and thick clay foundation layer), consider the elimination of the approach slab and plan for repair of the settlement problem by placement of asphalt overlay layers every few years (It is the cheapest approach over the long-term).
- If a tiered MSE wall system would be employed around and below the bridge abutment wall as in the Salt Creek and Founders/Meadows bridges, it is suggested to
 - Extend the reinforcements of the lower wall beyond the leveling pad of the upper MSE wall and increase their length from the base on a one to one slope as often performed for the front MSE wall.
 - The reinforcements of the upper MSE wall shall be wrapped around as was performed for the reinforcements placed behind the abutment wall

7.3.3 Better Support and Drainage Systems for the Sleeper Slab

Based on the presented study findings, more of the high quality backfill materials (not only 4 ft) should be placed only under the sleeper slab. Additionally, it is very important to collect and drain any surface water before it reaches and softens the soil layers located beneath or around the sleeper slab. As a part of a new research project along the 120th Avenue, the study panel agreed to investigate the performance of new systems for the support and drainage of the sleeper slab. The study panel included Dr. Trever Wang from Bridge, Mr. C.K. Su from CDOT Materials, Mr. Rene Valdez from Region 6, and Dr. Naser Abu-Hejleh from the CDOT Research Branch. The two systems recommended for support of the sleeper slab are:

- Driven piles and class 2 backfill (or embankment soil, simply any soil that should be compacted to meet the compaction requirements, see Figure 7.1). The expensive granular backfill and reinforcements are eliminated in this system. It was decided to avoid the design of a stiff driven pile foundation system that would not allow any settlement of the sleeper slab and would move the settlement problem down the roadway side. Some limited settlements (< 0.0025 the approach slab length) of the sleeper slab will control the changes in the slope grades around the sleeper slab. It would allow for engagement of the soil under the sleeper slab in supporting part of the loads (driven piles will provide partial support to the loads) and minimize the chances for development of voids under the sleeper slab. It was decided in the 120th project to use HP 10 x 57 steel piles spaced at 10 ft and driven to a minimum length that extends at least 2 ft into the native soil material (extends beyond the fill materials). Only dead loads are considered in computing the design loads. It was recommended to conduct PDA testing for estimation of the ultimate capacity of the piles at various depths. It was recommended by the PI to select depth of piles using a factor of safety of 1 (the depth where the measured geotechnical capacity of the pile matches the design load). It was also recommended to raise the sleeper slab by $\frac{1}{2}$ inch to compensate for the post construction settlements. Based on the PDA results, last minute changes to the spacing and tip elevations of the driven piles and the need to raise the sleeper slab should be determined. The dimensions of the sleeper slab should be increased to accommodate the embedment of the piles and to provide adequate clearance for the reinforcements.

- Placement of the high quality MSE backfill under the sleeper slab (Figure 7.2), not under the approach slab (as currently employed by CDOT) that will not support any load. The idea behind this system is to move the high quality MSE backfill from the abutment wall to an area around and below the sleeper slab where the support is needed. Add an additional perforated drain pipe (wrapped with filter fabric) at the bottom of the MSE fill and extend it to day light with non-perforated pipe (Figure 7.2).

In both systems, it is recommended to place a drainage layer and a drain pipe below the back of the abutment wall as in current CDOT standards. It is also suggested to fill the gap behind the abutment wall with medium (not low) density 3" polystyrene sheets.

To improve the drainage details around the sleeper slab, additional drainage details were proposed:

1. Place an impervious membrane with a collector pipe under the approach slab and an impervious membrane with a collector pipe under the approach roadway (Figure 7.1). Sand or filter aggregates can be placed around the pipes. This extended membrane system will collect the water that penetrate the cracks and joints.
2. Limit the membrane to locations under the joints only (Figure 7.2). This will lead to significant savings on the membrane material but it will not collect the water that penetrates through the cracks.
3. Under joints, place a gutter and 3" half circle PVC pipe to drain water. This is the most cost-effective mean for draining out the infiltrated water. Figure 7.3 shows the details of this system with an expansion joint placed above the abutment wall.

7.3.4 Approach Slab

- The length of approach slab should be related to the depth of abutment wall and the magnitude of the projected post-construction settlements. The length of the slab, L , should be selected to ensure that $\Delta < 0.005L$, where Δ is the difference between post-construction settlement of the sleeper slab and post-construction settlement of the abutment wall (the later can be conservatively assumed 0). Note that a longer approach slab requires a structural design with possibly larger concrete thickness and amount of reinforcements.
- Smoothness requirements around the bridge expansion joints should be applied. No such requirements are available within 25 ft of each joint.
- The special project provisions or plans should state that the contractor shall install the expansion devices at an elevation to be determined in the field by the Engineer who can request for minor adjustment of the design elevation of the expansion devices if deemed feasible. Prior to installing the expansion device, the contractor should be required to report the as built surveyed grades of the bridge and the approaching roadway (often constructed to within approx. 50' +/- of the bridge). The expansion device should be installed at an elevation that corresponds to a smooth line (using string line) between the end of the bridge and the roadway. This will

ensure that the approach roadway and approach slab are constructed to match the as constructed grades of the bridge and roadway. This is recommended to avoid the construction of a bump at the end of the construction as discussed before.

- If approved by the hydraulic and structural engineers, install the expansion device at an elevation higher by up to one inch (for approach slab of 20 ft long) than the straight grade elevation determined before to compensate for the anticipated post-construction settlement. Note that vertical curves and roadway geometry create other obstacles, but in general that specification would be beneficial.
- In some cases where the settlement problem would be significant and continue for an extended periods, elimination of the approach and sleeper slabs altogether should be consider. As an alternative, full-depth asphalt approach slabs could be used with maintenance overlays as needed.

7.3.5 Flowfill Abutment Backfill

Add to the construction specification a new requirement to vibrate the flowfill. Tighten the QA requirements to ensure a uniform flowfill. Pay the contractor per the plan design volumes, not the placed quantities. A recent CDOT research study was approved for funding that would improve CDOT construction specifications for the flowfill and reduce its costs.

7.3.6 MSE with Class B Filter Material

To ensure appropriate compaction level for this backfill material, the study recommends using compaction specifications similar to those established for rocky embankments (see Section 2.6). Concrete wing walls should be used with this material to ensure lateral confinement.

7.3.7 MSE Backfill & Embankment

- CDOT QA (quality assurance) procedure of the placed fill, especially compaction level, should be enhanced by: 1) increasing the frequency of testing and, 2) eliminating the use of any frozen fill that leads to erroneous readings for the compaction level.

- If project construction schedule allows, consider placement of temporary fill on top of the approach fill soils (preloading) for the longest possible period of time. This will reduce the post construction settlements of the sleeper slab.
- Compact granular fill and embankment material wet of the optimum. After compaction is completed, spray the soil with water to increase its moisture content.
- Assume the active horizontal pressures exerted by the MSE backfill on the facing of the abutment wall as half of those calculated for the conventional retaining walls.
- Take the location of the maximum tension line of the MSE system placed behind the abutment wall at or behind the back of the sleeper slab. Use of geotextile type of reinforcements is expected to provide adequate factor of safety against breakage and pullout failure of the reinforcement.
- Plan for an overall continuous stretching or expansion of the MSE backfill of approximately 1.5 to 2 mm every year. This movement could lead to settlement problems.
- Tighten CDOT specifications for compaction of the top of the foundation soil layer. CDOT project personnel should require compaction even if the top of the foundation soil layer is dried and seems very stiff.

7.3.8 Influence of Temperature Changes on Integral Abutments

Temperature has a significant effect on integral abutments. During the warm days and seasons, the Founders/Meadows superstructure expands, pushing the abutment into the backfill. During the cold days and seasons, the superstructure contracts, pulling the abutment away from the backfill. This leads to the continuous cyclic lateral movements of the MSE backfill with time (compression and expansion movement estimated at 4 mm) and to cyclic lateral earth pressures (passive and active) against the abutment wall.

- Assume a relatively low and uniform passive earth pressure of 35 kPa (during the summer time), not the passive earth pressure estimated for conventional retaining walls with rigid facing

and unreinforced soil backfill. The difference between the day and night measured horizontal earth pressures against the abutment wall can be as high as 25 kPa.

- Improve CDOT details for the upper zone of the MSE approach because the presence of polystyrene was not fully effective in reducing the passive lateral earth pressure resulting from the expansion of the bridge superstructure. It is recommended to use softer (less dense) and thicker form of polystyrene sheet in that zone.

7.3.9 Foundation Investigation at Bridge Approaches

Subsurface Geotechnical Investigation

- Consider the following guidelines in selecting the locations for the test holes
 - Drill some test holes at the expected location of the sleeper slab.
 - Select locations where the foundation soil layer experienced the lowest level of consolidation (depth of existing fill is shallow like sides of an old bridge).
 - Select locations where the future fill height above the original ground level is expected to be the highest (highest potential for future consolidation settlement).
- Apply seasonal corrections to the collected SPT data if they are collected during the dry or cold seasons of the year. These corrections should take into account possible reduction in the soil strength from the values estimated in the subsurface geotechnical investigation due to future increase in the soil moisture (rise in the GWT) and temperature (see Chapter 3 for influence of these factors).

Settlement Analysis:

- Lowering the GWT will add the loads on the foundation soil layer and this should be accounted for in the settlement analysis.
- Estimate magnitude and timing of the post-construction short- and long-term settlements of the sleeper slab as demonstrated in this study. The sources of these settlements are the fill and foundation soil layers (both can range from granular to cohesive soils). As discussed before, the ratio between anticipated long-term differential settlement and length of the approach slab should be kept lower than 1/200. As presented in the study findings, the assumption that the post-

construction settlement of the fill material is equal to 1% of the fill height is on the conservative side.

7.3.10. Bridge Expansion Device

More improvements to CDOT bridge expansion joints are needed to prevent cracking of the concrete approach slab that lead to seepage of surface water into the soil under the sleeper slab.

- Increase the maximum width of the joint to more than 4” (perhaps 6”) but note that the joint may be prone to snow blow damage.
- Place the expansion device over the abutment wall to prevent the approach slab from dragging and then cracking.

As in other states, it is also recommended to include performance standards for new joint seals to ensure the joint does not leak. Alternatively, change CDOT current details to collect the water passing through the joints as was discussed before. Note that some southern states utilize an open joint with collection system. See in the study finding section the observations reported in NCHRP Synthesis 319 for the premolded strip seal joints, open joints, and modular system joints.

7.3.11 Drainage Measures

- Make it standard (not a designer choice) to place a drainage inlet at end of a bridge deck before getting to the approach slab when it is appropriate. (e.g., the bridge has a crown section).
- Make the drains grates larger as some drains become plugged because the openings are too small.
- Improve the internal drainage system. Solve current problems with drainage pipes- in many cases we do not see water coming from the drainage pipes.
- If needed and feasible, some horizontal drainage measures should be installed from the side of the structure to remove the water from the interface zone between a granular soil layer (often embankment) and a cohesive soil layer (often a foundation soil layer). In this case, it is noticed that the water accumulates on top of the cohesive soil layer and softens it.

7.3.12 Repair of Colorado Bridge Approaches

- Follow the forensic investigation guidelines developed in Chapter 3 and applied in Chapters 4 and 5 to determine the causes and sources of the approach settlement problems. Chapter 3 also provides description of *all* possible causes of the bridge approach settlement problem. Typical causes for the bridge approach settlement problems in Colorado were discussed in Section 7.1.2.
- Use of deep foundation to repair bridge approaches is a viable alternative and should be considered in the future.
- There are mixed opinions on the performance of the Uretex method for stabilization so the performance of approaches repaired with this technique should be monitored in the future.
- The performance of the compaction grouting for repair of bridge approaches appears fine but the performance of approaches repaired with this technique should be monitored in the future.

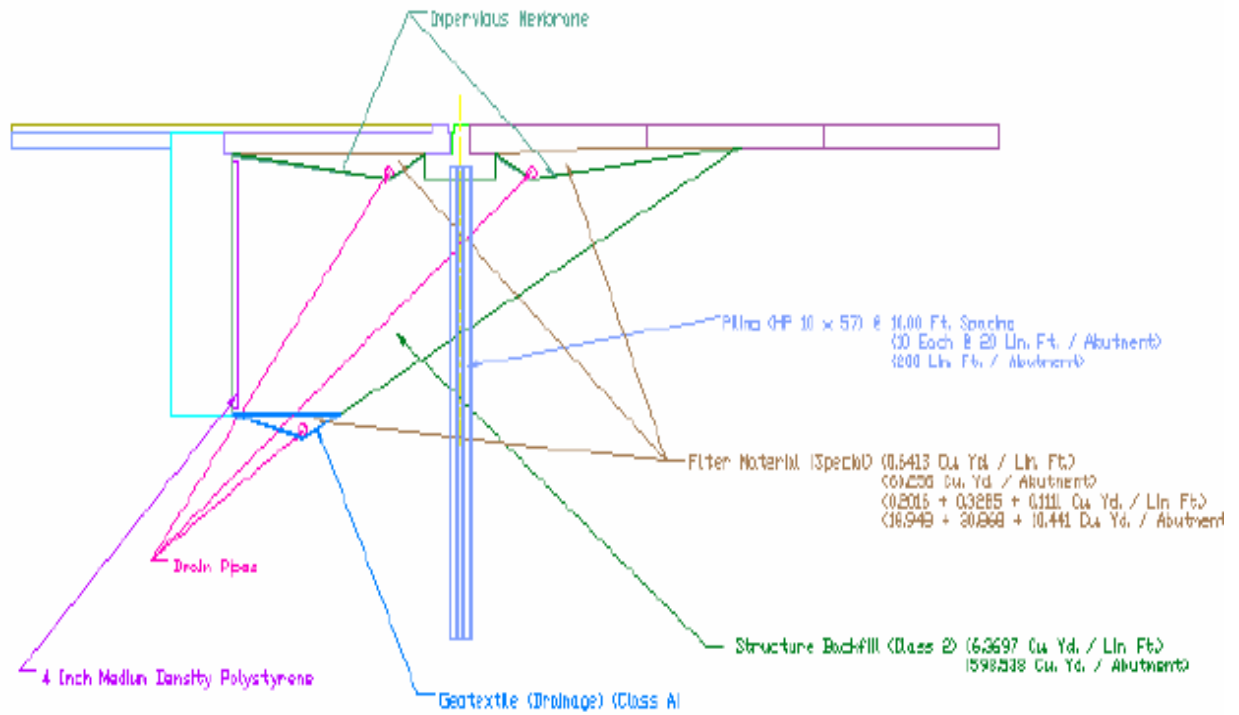

Figure 7.1. The Driven Pile System Proposed for the 120th Project Bridge Approaches.

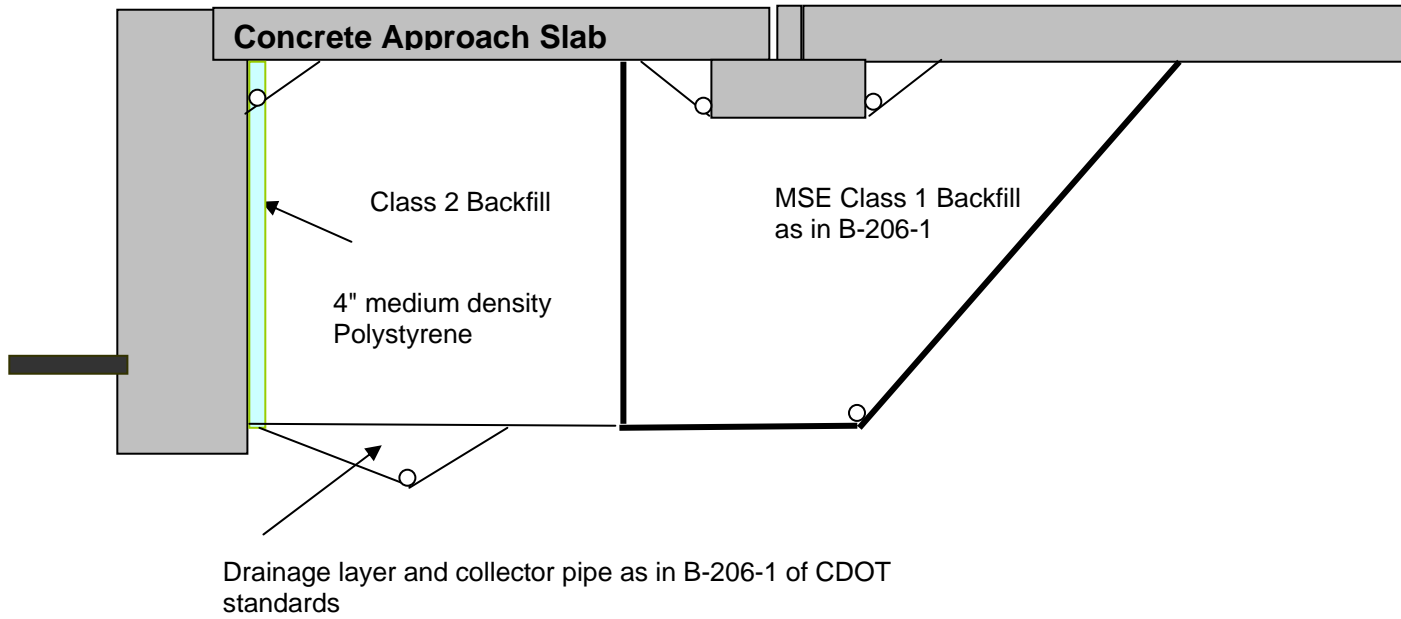
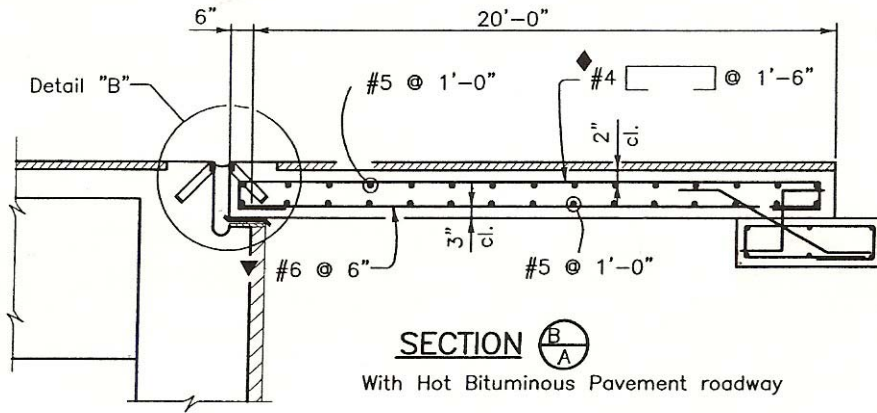
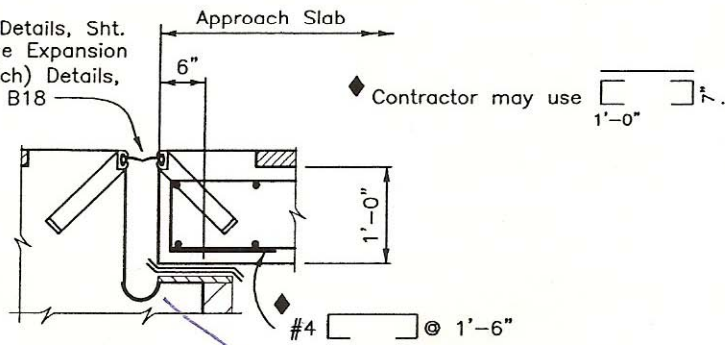

Figure 7.2. The MSE Wall System under the Sleeper Slab Proposed for the 120th Project Bridge Approaches.



See Abutment Details, Sht. B08, and Bridge Expansion Device (0-4 Inch) Details, Shts. B17 and B18



DETAIL "B"

3" ϕ HALF CIRCLE
PVC PIPE

Figure 7.3. The Most Economical Form of Drainage System Recommended for the Sleeper Slab.

REFERENCES

1. AASHTO (2002). Standard Specifications for Highways Bridges. American Association of Highway and Transportation Officials, Washington, D.C., 17th Edition.
2. AASHTO (1988). Manual on Subsurface Investigations, American Association of State Highway and Transportation Officials, Washington, DC, 1988. 391 pages.
3. Abu-Hejleh, N., O'Neill, M., Hanneman, D., and Attwooll, W. (2003). Improvement of the Geotechnical Axial Design Methodology for Colorado's Drilled Shafts Socketed in Weak Rocks. Colorado DOT, CDOT-DTD-R-2003-6. Denver. 192p.
4. Abu-Hejleh, N., Zornberg, J., Outcalt, S., and McMullen, M. (2001). "Results and Recommendations of Forensic Investigation of Three Full-Scale GRS Abutment and Piers in Denver, Colorado." *Report No. CDOT-DTD-R-2001-6*, Colorado Department of Transportation.
5. Abu-Hejleh, N., Zornberg, J., Wang, T., McMullen, M., and Outcalt, S., 2001, "Performance of Geosynthetic-Reinforced Walls Supporting the Founders/Meadows Bridge and Approaching Roadway Structures, Report 2: Assessment of the Performance and Design of the Front GRS Walls and Recommendations for Future GRS Abutments", Report No. CDOT-DTD-R-2001-12, Colorado Department of Transportation.
6. Abu-Hejleh, N., Wang, T., and Zornberg, J. (2000). "Performance of Geosynthetic-Reinforced Walls Supporting Bridge and Approaching Roadway Structures." ASCE/Geotechnical Special Publication No. 103, Advances in Transportation and Geoenvironmental Systems Using Geosynthetics, Proceeding of Sessions of GEO-Denver 2000, Denver, USA, 218-24.
7. Abu-Hejleh, N., Outcalt, S., Wang, T., and Zornberg, J. (2000). "Performance of Geosynthetic-Reinforced Walls Supporting the Founders/Meadows Bridge and Approaching Roadway Structures, Report 1: Design, Materials, Construction, Instrumentation, and Preliminary Results." Report No. CDOT-DTD-R-2000-5, Colorado Department of Transportation.
8. Biriaud, J-L., James, R.W., and Hoffman, S.B. (1997). "NCHRP Synthesis 234: Settlement of Bridge Approaches (The Bump at the End of the Bridge)." Transportation Research Board, National Research Council, Washington, D.C., 75 pp.
9. Coduto, D.P. (2001). "Foundation Design: Principles and Practices, 2nd Edition." Prentice Hall. 883 pages.
10. Hoppe, E.J., and Gomez, J.P. (1996). Field Study of an Integral Backwall Bridge. Report Prepared for Virginia Transportation Research Council, 47 pages.

11. Hotchkiss, A. (2004). Bridge Approach Settlement at Structure E-19-Z on US 36 East of Bennett. A memorandum prepared by CDOT Soils and Foundation Program.
12. Kssouri, I. (2001). "Approach slab settlement: Corrective Recommendations for Structure E-17-PR, I-76 at 136thAve. East and West Approaches." A memorandum prepared by CDOT Soils and Foundation Program.
13. Nusairat, J., Liang, R.Y., Hanneman, D., Abu-Hejleh, N. , and Yang, K. (2004). Drilled Shaft Design for Sound Barrier Walls, Signs, and Signals. Colorado DOT, CDOT-DTD-R-2004-8. Denver. 414 pages.
14. Purvis, R. (2003). "NCHRP Synthesis 319: Bridge Deck Joint Performance." Transportation Research Board, Research Council, Washington, Washington, DC, 2003. 46 pages.
15. Reid, R.A., Soupir, S.P., and Schaefer, V.R. (1998). " Use of Fabric Reinforced Soil Walls for Integral Bridge End Treatment." *Sixth International Conference on Geosynthetics*, Atlanta, Georgia, March, 573-576.

**APPENDIX A. CONSTRUCTION DETAILS OF CDOT'S BRIDGE
APPROACHES**

DESIGN	DATE	BY	CHKD	REV
DESIGN	DATE	BY	CHKD	REV
DESIGN	DATE	BY	CHKD	REV
DESIGN	DATE	BY	CHKD	REV
DESIGN	DATE	BY	CHKD	REV
DESIGN	DATE	BY	CHKD	REV
DESIGN	DATE	BY	CHKD	REV
DESIGN	DATE	BY	CHKD	REV
DESIGN	DATE	BY	CHKD	REV
DESIGN	DATE	BY	CHKD	REV
DESIGN	DATE	BY	CHKD	REV
DESIGN	DATE	BY	CHKD	REV

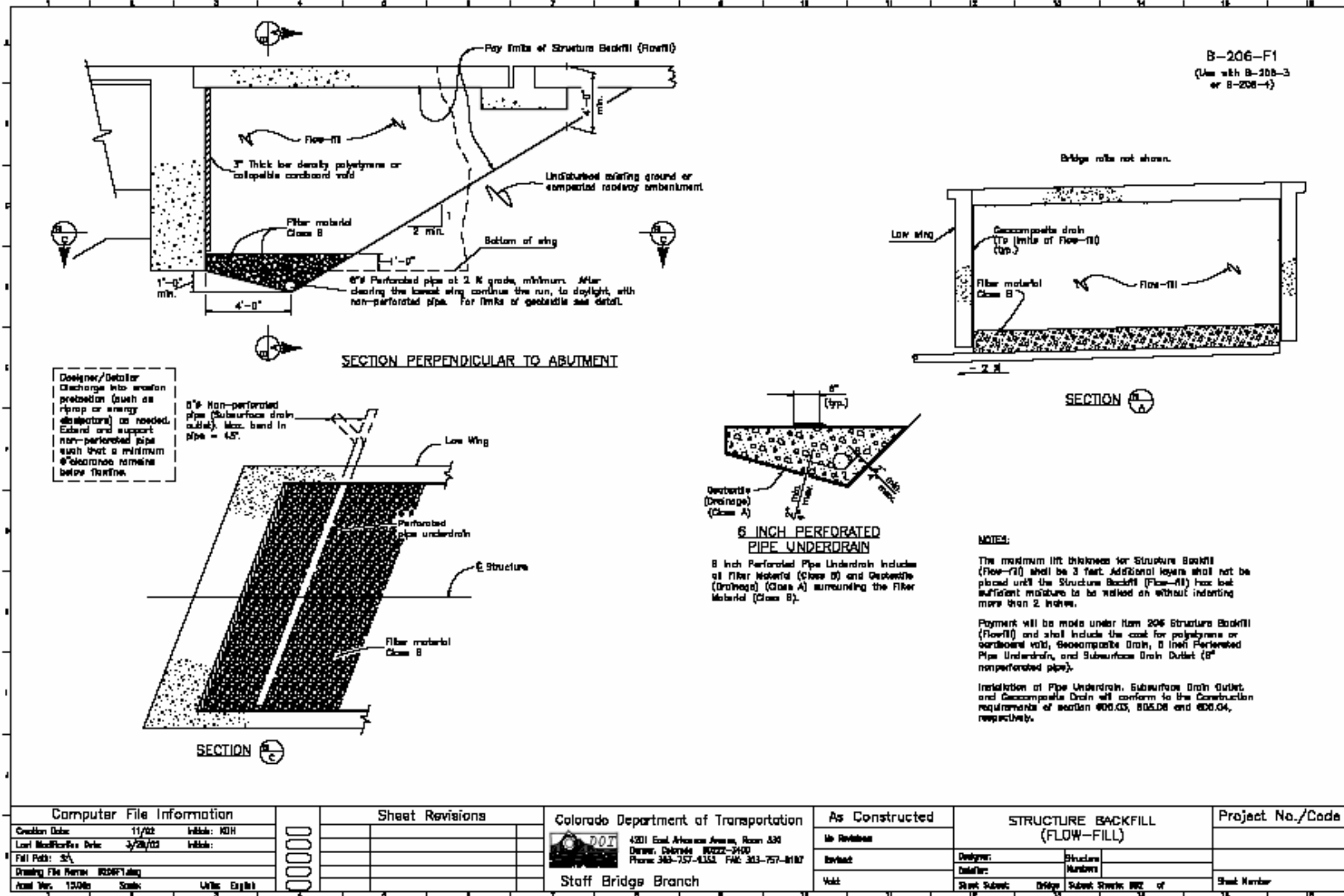

Figure A.1. Details for Flowfill Bridge Approaches

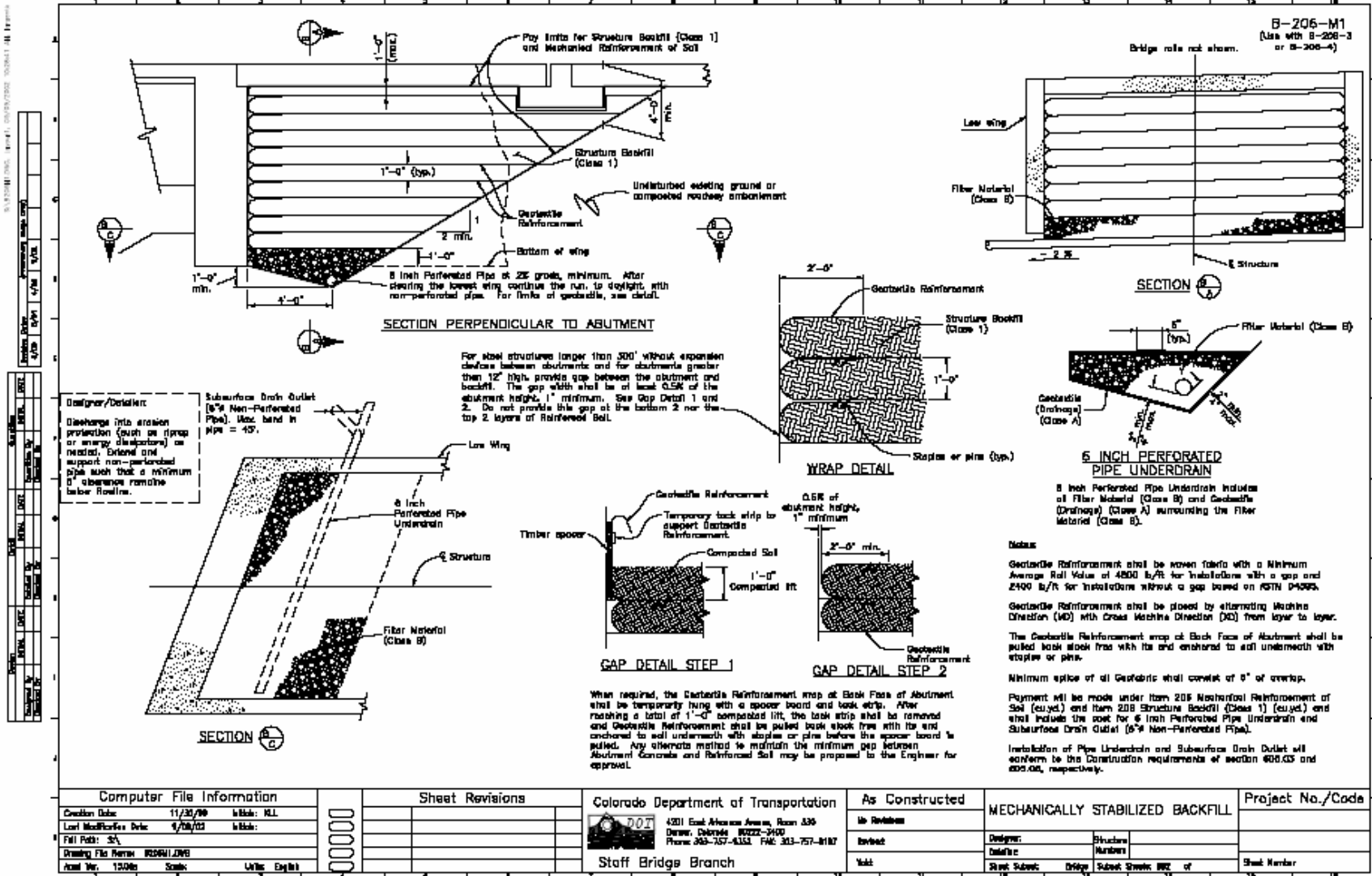

Figure A.2. Details for Bridge Approaches Constructed with MSE Class 1 Backfill

DESIGNER	DATE	SCALE	BY	CHECKED	DATE

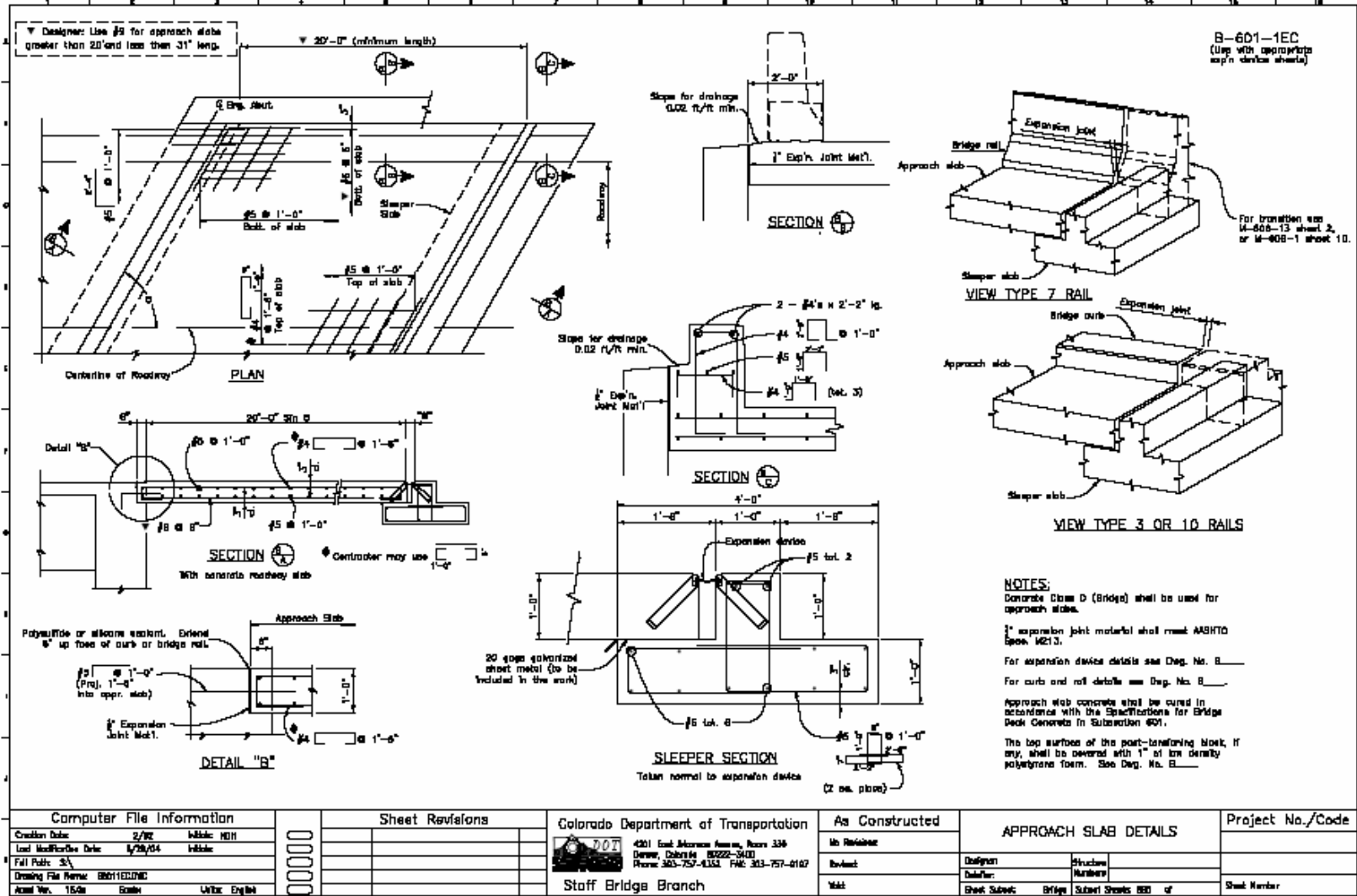

Figure A.3. The Concrete Approach Slab Details

**APPENDIX B. DETAILED PERFORMANCE DATA OF CDOT'S
FLOWFILL AND MSE BRIDGE APPROACHES**

Table B.1 List of Bridges constructed in Colorado with Concrete Approach Slab and Flowfill Abutment Backfill Material

Region	Bridge	Highway	Section Letter	Mile Pt.	Built	subac	span/type	# of bridges	Quantity of flowfill (CY)
4	D-20-AR	76	A	64.111	1993	91035	5	3	862
4	D-20-AS	76	A	64.11	1993	91035	5	3	862
4	D-20-AT	34	A	149.32	1993	91035	2	3	862
5	N-10-W	149	A	1.031	1993	90058	3	1	315
4	B-24-AS	76	A	124.76	1994	91036	2	2	800
4	B-24-AT	76	A	124.76	1994	91036	2	2	800
4	E-16-MU	287	C	300.41	1994	84076	1	1	900
6	E-16-OQ	25	A	213	1994	92024	1	1	1244
4	E-16-PQ	287	C	303.9	1994	93227	2	1	1720
6	E-17-PQ	76	A	19.16	1994	89015	3	4	2123
6	E-17-PR	76	A	19.71	1994	89015	2	4	2123
6	E-17-PS	76	A	20.868	1994	89015	2	4	2123
6	E-17-PT	76	A	20.869	1994	89015	2	4	2123
6	E-17-QA	270	N	0.01	1994	92311	5	1	1981
6	E-17-SW	225	A	11.998	1994	92913	8	1	2370
3	H-02-GJ	340	A	12.973	1994	92051	5	1	280
2	I-18-BE	24	G	309.76	1994	91303	1	1	3863
4	C-21-BM	34	B	159	1995	92019	2	1	836
4	C-22-BT	71	E	181.48	1995	92067	9	1	346
6	E-16-PM	70	A	269.45	1995	93271	4	1	2282
1	F-15-CZ	74	A	3.031	1995	10792	3	1	1839
6	F-16-RY	285	D	257.19	1995	92313	3	1	820
1	F-16-SB	285	D	244.1	1995	93015	3	1	670
1	G-17-DE	25	A	181.89	1995	10580	2	1	738
2	I-17-JE	24	G	304.74	1995	92992	3	2	363
2	I-17-JF	24	G	304.79	1995	92992	2	2	363
2	N-17-BR	160	A	299.4	1995	92049	3	1	260
4	C-20-AS	39	A	7.13	1996	90111	5	2	552

4	C-20-AT	39	A	6.899	1996	90111	3	2	552
4	C-21-BL	144	A	20.3	1996	92421	7	1	211
6	E-16-PL	70	A	269	1996	93271	1	1	2282
4	E-16-PN	287	C	302.65	1996	10185	2	1	634
6	E-16-PT	121	A	18.023	1996	90448	3	1	1196
6	E-16-OR	25	A	213.5	1996	10602	1	3	2743
6	E-17-VR	44	A	1.075	1996	92904	2	1	1180
1	F-15-DA	74	A	3.03	1996	10792	3	1	1839
6	F-16-LZ	70	A	262.57	1996	10304	2	1	1020
1	F-20-BY	36	D	100.24	1996	92057	4	1	730
1	G-17-DF	25	A	181.85	1996	10580	2	1	738
2	I-17-KZ	83	A	18.189	1996	10178	2	1	695
2	K-18-GA	47	A	2.412	1996	11169	1	1	558
5	O-09-U	160	A	149.12	1996	10227	1	1	650
6	E-16-QQ	25	A	212.98	1997	10602	1	3	2743
6	F-17-KL	225	A	6.886	1997	11248	2	1	1295
6	F-17-KQ	470	A	0	1997	10305	2	1	791
1	F-19-BH	70	A	307.41	1997	11328	3	2	434
1	F-19-BI	70	A	307.41	1997	11328	3	2	434
3	H-02-GK	50	A	32.183	1997	93135	8	1	607
2	L-21-DA	50	B	355.11	1997	91067	3	2	794
2	L-21-DB	50	B	358.46	1997	91067	1	2	794
2	O-18-CN	25	A	23.195	1997	91025	2	2	540
2	O-18-CO	25	A	22.345	1997	91025	2	2	540
6	E-16-ON	25	A	0	1998	10602	10	3	2743
3	B-04-F	40	A	63.073	1998	11393	2	1	198
4	D-17-DI	25	A	240.11	1998	91033	3	1	768
6	E-16-ON	25	A	0	1998	10605	10	1	743
6	E-17-QM	36	B	56.996	1998	11149	5	5	1343.8
6	E-17-QN	36	B	56.995	1998	11508	2	5	2814
6	E-17-QO	270	A	0.04	1998	11149	1	5	1343.8
6	E-17-VS	224	A	0.475	1998	11918	3	5	92
6	E-17-VT	224	A	0.49	1998	11149	1	5	1343.8
6	F-17-MG	25	A	202.64	1998	11515	2	1	640
1	G-27-AE	24	C	445.52	1998	11625	2	1	331

2	K-18-GB	25	A	114.18	1998	10177	2	1	178
4	B-17-DS	68	A	4.447	1999	91034	3	1	728
4	B-23-AV	14	C	224	1999	12042	6	1	420
4	C-16-AQ	34	A	91.859	1999	92052	1	1	1024
4	C-16-DK	287	C	323.57	1999	12188	1	1	654
4	C-17-AZ	34	D	5.097	1999	11574	1	1	308
4	C-17-FO	257	A	5.145	1999	11202	2	2	1518
4	C-17-FP	257	A	5.149	1999	11202	2	2	1518
4	C-23-AO	6	J	390.07	1999	92962	3	1	259
3	D-13-G	34	A	3.616	1999	11431	1	2	610
3	D-13-H	34	A	3.452	1999	11431	1	2	610
6	E-15-AL	93	A	10.4	1999	93194	1	2	1087
6	E-16-NF	93	A	6.95	1999	93194	1	2	1087
6	E-16-PY	6	G	271.69	1999	91130	1	1	651
6	E-17-MX	2	C	18.703	1999	12055	1	4	1850
6	E-17-UF	2	C	18.999	1999	12055	2	4	1850
6	E-17-UH	2	C	18.883	1999	12055	3	4	1850
6	E-17-UJ	2	C	19.1	1999	12055	1	4	1850
6	E-17-QP	270	N	0.02	1999	11508	6	1	1568
6	E-17-WP	266	A	3.308	2000	92983	4	1	2455
1	F-12-I	6	F	212.86	1999	11923	1	1	446
1	F-15-AC	74	A	11.96	1999	10584	3	1	945
1	F-15-BX	70	A	243.04	1999	86019	3	3	3038
1	F-15-BZ	70	A	243.04	1999	86019	3	3	3038
1	F-15-CR	70	A	242.98	1999	86019	1	3	3038
6	F-16-TR	40	C	297.51	1999	93193	1	1	696
1	F-17-CR	25	A	191.13	1999	12193	1	2	2595
1	G-17-T	25	A	189.76	1999	12193	1	2	2595
1	G-22-BX	71	C	100.92	1999	11950	4	1	359
2	K-18-GC	47	A	0.155	1999	11931	2	1	1709
5	P-05-H	550	A	1.227	1999	93084	1	2	794
5	P-05-I	550	A	1.951	1999	93084	1	2	794
2	P-20-T	160	C	366.03	1999	92999	2	2	653

2	P-20-U	160	C	374.21	1999	92999	2	2	653
4	A-27-P	138	A	55.094	2000	10786	3	1	316
1	E-14-BH	40	A	257.46	2000	11739	1	1	190
6	E-17-WZ	270	A	2.359	2000	11349	2	1	945
1	F-15-AD	40	B	274.17	2000	12310	1	1	525
1	G-22-BY	24	G	376.56	2000	91044	4	2	1224
1	G-22-BZ	24	G	376.71	2000	91044	3	2	1224
2	I-15-AV	24	A	264.7	2000	11351	1	1	971
4	C-20-Q	144	A	6.633	2001	11730	4	1	411
6	E-16-RB	36	B	55.931	2001	11951	2	1	962
6	E-17-UQ	70	A	274.71	2001	11507	2	1	265
2	I-17-NE	83	Q	25	2001	12718	3	1	1434

Table B.2.* List of Bridges Constructed in Colorado with Concrete Approach Slabs and MSE Abutment Backfill (Class 1 and Class B Backfill) Material

	Region	Bridge	Hiway	Section Letter	Mile Pt.	Built	subac	Quantity (CY)
Unique Structure: Abutment walls are supported by Shallow Foundations								
Class 1	1	G-17-T*	25	A	189.76	1999	12193	
Abutment walls are supported by Deep Foundations								
Class 1	4	D-17-AP	52	A	11.167	1999	11588	2758
Class 1	4	E-16-QU	36	B	44.55	2000	12359	557
Class 1	1	E-19-Z	36	D	90.015	2000	92312	190
Class 1	6	F-17-DZ	225	A	8.05	2000	12482	4782
Class 1	2	I-18-AC	24	G	311	2000	13240	3792
Class 1	2	J-18-AI	85	A	132	2001	12858	2424
Class 1	2	N-18-AA	25	A	47.179	2001	12393	456
Class 1	6	E-17-UZ	7	D	70.576	2002	13178	302
Class 1	1	F-19-M	36	D	93.301	2002	13379	480
Class 1	2	J-17-AA	115	A	31.285	2002	11955	1303
Class 1	2	K-16-CH	115	A	18.881	2002	11955	1303
Class 1	2	K-18-GG	25	A	101.39	2002	12583	9520
Class 1	2	L-20-A	96	B	84.25	2002	12829	1422
Class B	6	E-17-UG	76	A	17.051	2001	12056	
Class B	6	E-17-UL				2001	12056	
Class B	6	E-17-UM				2001	12056	
Class B	6	E-17-UN				2002	12056	
Class B	6	E-17-UK				2002	12056	
Class B	4	Structures D-17-DN and D-17-DM				I-25 over CT RD 6		
Class B	4	Structures D-17-CR and D-17-CT				I-25 over Ct. Rd 10		
Class B	4	Structure D-17-DY				I-25 over Ct. Rd 10		

* There are two structures in Region 4 where Flowfill and MSE Backfill Materials were placed side by side in the same structure, see Chapter 4 and Table B.5.

Table B.3 List of Bridges in Colorado with Worst Approaches

Region	Bridge	Hiway	Mile Pt.	Built
6	E-17-PR	76	19.71	1994
6	E-17-PT	76	20.869	1994
6	E-17-SW	225	11.998	1994

6	E-16-PL	70	269	1996
6	E-16-OR	25	213.5	1996
2	I-17-KZ	83	18.189	1996
6	E-16-QQ	25	212.976	1997
3	H-02-GK	50	32.183	1997
6	E-17-QO	270	0.04	1998
1	F-15-BX	70	243.04	1999
6	E-17-WP	266	3.308	2000
6	E-16-OQ	25	213	1994
6	E-17-PQ	76	19.16	1994

Table B.4. 2004 Performance Results of Flowfill and MSE Bridge Approaches in Region 6

Rating based on Approach Settlement		Bridge Information				Rating Based on Staff Bridge Inspection Records				
Rating	Comments	Bridge	Hiway	Mile Pt.	Built	# of Appro	fair	poor	good	Comments
Flowfill Abutment Backfill										
1	Low Approaches	E-16-OQ	25	213	1994	2	1	0	1	Slabs OK but both approach rdwys appear 1/4" low. #1 @ rt bounces slightly under heavy loads.
2	Repaired but construction left a bump	E-17-PQ	76	19.16	1994	2	1	0	1	Approach slab @ A1 has been replaced due to past settlement. Looks good. Some minor settlement
3	3" of settlement on east approach and to a lessor extent on west side	E-17-PR	76	19.71	1994	2	2	0	0	Many longit cracks, some open to 1/16". No evidence of settlement.
1	Settlement around 1", voids were noticed	E-17-PS	76	20.87	1994	2	0	0	2	Many light longit. cracks in both.
1	Settlement of around 1"	E-17-PT	76	20.87	1994	2	2	0	0	3 or 4 longit cracks full length in both slabs, open to 1/16" +/- . Minor scale on #1.
2	East: Sleeper slab drops of around 2", concrete is bust around exapnsion joint	E-17-QA	270	0.01	1994	2	0	0	2	Asph. covered on right lane only @ A6. Few lite longit. cracks in both. No problems.
3	East drop of 3-4" inches	E-17-SW	225	12	1994	2	2	0	0	No settling but each has three 1/16"+/- longit. cracks.
1	OK	E-16-PM	70	269.5	1995	4	0	0	4	Few lite longit. cracks. No settling.
1	Slightly low approaches	F-16-RY	285	257.2	1995	2	0	0	2	Covered with asphalt surface, no problems seen.
1	Slightly low approaches	E-16-PL	70	269	1996	2	2	0	0	Several longitudinal cracks in forward slab in East bound lanes and rear slab, west bound lanes.
1	North side settled less than 1"	E-16-PT	121	18.02	1996	2	0	0	2	Covered with asphalt. No visible settlement.

1	Low Approaches	E-16-OR	25	213.5	1996	2	2	0	0	Numerous lite to 1/16" diag. cracks (perpendicular to skew) spaced 4' to 6'.
2	Settlement of 1" East side, 2" west side, approaching roadway settled significantly around 3", short approach slab of 6' to 8' making the problem worsen, Asphalt meet concrete, rated 2 because of low SL	E-17-VR	44	1.075	1996	2	0	0	2	Same elevation as deck. Several diagonal cracks.
1	Roadway on both sides of the approach slab settled.	F-16-LZ	70	262.6	1996	2	0	0	2	Asphalt covered, no cracks just begining signs of unraveling. No apparent settlement.
1	Slightly Low approaches	E-16-QQ	25	213	1997	2	2	0	0	Longit cracks spaced 4' at both slabs.
1	West side, Approach drop 1"	F-17-KL	225	6.886	1997	2	0	0	2	Few lite longit. cracks seen on forward slab near sidewalks.
1	Settlement Less than 1"	F-17-KQ	470	0	1997	2	0	0	2	Light longit cracks in both.
1	OK	E-16-ON	25	0	1998	2	1	0	1	#1 shows mod. trans. & longit. cracks and is 1/2" low at the left corner of A-1.
1	Slightly low approaches	E-17-QM	36	57	1998	2	0	0	2	Few light longit. cracks in both.
1	West sleeper: drop of around 1"	E-17-QN	36	57	1998	2	0	0	2	Mod longit cracks in #1. Light diagonal cracks in #3.
2	East Approach drop around 2", worsen as you get north	E-17-QO	270	0.04	1998	2	2	0	0	Light longit. cracks in both. Light trans. crack in #1 full width.
1	South: settlement of 1"	E-17-VS	224	0.475	1998	2	0	0	2	Both look good.
1		E-17-VT	224	0.49	1998	1	0	0	1	Four 1/32" longit. cracks in approach slab at rear.
1		F-17-MG	25	202.6	1998	2	0	0	2	Still same elevation as deck. Covered with asphalt. Look good.

1	Both approaches are slightly low	E-15-AL	93	10.4	1999	2	0	0	2	Asphalt covered. Look good. Scuppers on Rt. side of both approach slabs appear to be installed backwards.
1		E-16-NF	93	6.95	1999	2	0	0	2	Asphalt covered, OK.
1		E-16-PY	6	271.7	1999	2	0	0	2	Covered with asphalt.
1	Good	E-17-MX	2	18.7	1999	2	0	0	2	3 longit cracks at rear slab have been epoxy sealed. Some longit cracks in W.Bnd lane at fwd slab.
1	Settled around 1", Ok SL 45 MPH	E-17-UF	2	19	1999	2	0	0	2	Few lite longit. cracks on both slabs. One has been epoxy sealed at forward slab.
1	Slightly low approaches, probably built that way	E-17-UH	2	18.88	1999	2	0	0	2	Longit. trans. and diag. cracks at both approach slabs. Some have been sealed.
1	slightly low approaches, roadway high on both approaches	E-17-UJ	2	19.1	1999	2	0	0	2	Few lite longit. cracks at appr. slabs, some have been epoxy sealed. Numerous lite surface cracks.
1	East side, drop of around 1"	E-17-QP	270	0.02	1999	2	0	0	2	Light diag. and pattern cracks in both.
1	Slightly low approaches	F-16-TR	40	297.5	1999	2	0	0	2	Look good.
1	West Roadway is high asphalt	E-17-WZ	270	2.359	2000	2	0	0	2	A few light random cracks.
1	Approach Settlements less than 1"	E-16-RB	36	55.93	2001	2	0	0	2	cracks in fwd. appr. slab @ shoulder area for EB lanes.
1		E-17-UQ	70	274.7	2001	2	0	0	2	Minor settlement at A1 rear, lt. side and at A3, fwd end.
1		E-17-WP	266	3.308	2000	3	1	1	1	Approach slabs asph. overlayed. No settlement.
MSE Abutment Backfill with Class 1 Backfill										

1	North Approach is 1" low	F-17-DZ	225	8.05	2000	2	0	0	2	Few light diag. cracks in both. Light trans. crack in #1 near abut. Some light random cracks in #4.
1	West side settlement around 1", may be built that way	E-17-UZ	7	70.58	2002	2	0	0	2	Approach slabs covered with asphalt. No problems seen.
MSE Abutment Backfill with Class B Filter Material										
1	Smooth and settlement less than 1", SL of 45 mph	E-17-UG	76	17.05	2001	2	0	0	2	3 to 4 lite longit cracks perpendicular to skew at each approach slab.
1		UK								
1		UL								
1		UM								
1		UN								

Table B.5. 2004 Performance Results of Flowfill and MSE Bridge Approaches Constructed in Region 4

Rating based on Settlement	Bridge Information				Rating based on Staff Bridge Inspection Records				Comments
	Bridge	Hiway	Mile Pt.	Built	# of Appro	fair	poor	good	
Flowfill Abutment Backfill									
1	D-20-AR	76	64.111	1993	2	0	0	2	Covered with asphalt. No apparent settlement.
1	D-20-AS	76	64.11	1993	2	0	0	2	Covered with asphalt surface.
1	D-20-AT	34	149.32	1993	2	0	0	2	Both covered with asphalt but no visible settlement.
1	B-24-AS	76	124.76	1994	2	0	0	2	Covered with asphalt, similar condition to deck.
1	B-24-AT	76	124.76	1994	2	0	0	2	Covered with asphalt. No signs of settlement at this time; A little washing along edges of slab at Abut. 1.
1	E-16-MU	287	300.41	1994	2	0	0	2	Small area with "D" cracking on forward approach slab between slab and deck. Settlement @ #1 rear end, next to rdwy appro., rt. lane the worst.
1	E-16-PQ	287	303.9	1994	2	0	0	2	Same elevation as bridge deck. Both covered with asphalt.
1	C-21-BM	34	159	1995	2	0	0	2	Covered with asphalt. Light random cracks in asph. and some erosion under fwd. slab.
1.5	C-22-BT	71	181.48	1995	2	0	0	2	No problems seen.
1	C-20-AS	39	7.13	1996	2	0	0	2	Asph. covered. No evidence of settling.
?	C-20-AT	39	6.899	1996	2	0	0	2	Both overlaid. Look good.
1	C-21-BL	144	20.3	1996	2	0	0	2	Approach slabs are overlaid. Look ok.
1	E-16-PN	287	302.65	1996	4	0	0	4	A couple of hairline cracks in A3 approach slab.

1	D-17-DI	25	240.11	1998	2	0	0	2	Asphalt covered, no problems seen.
1	B-17-DS	68	4.447	1999	2	0	0	2	No settling observed.
1	B-23-AV	14	224	1999	2	0	0	2	Covered w/ asphalt. Look good.
1	C-16-AQ	34	91.859	1999	2	0	0	2	Asphalt covered, no apparent settlement, looks good. Some settlement starting at #2 end.
3	C-16-DK	287	323.57	1999	2	0	0	2	Covered w/ asphalt.
1	C-17-AZ	34	5.097	1999	2	0	0	2	Covered with asphalt.
1	C-17-FO	257	5.145	1999	2	0	0	2	Covered with asphalt. Some erosion beneath #1 @ lt.
1	C-17-FP	257	5.149	1999	2	0	0	2	1" of settlement measured at A3 right curb, see 12-99 photo. Light concrete scaling @ A1 approach at plug expan. device.
1	C-23-AO	6	390.07	1999	2	0	0	2	Covered with asphalt. Look good.
1	A-27-P	138	55.094	2000	2	0	0	2	Both approach slabs are overlaid and have no signs of settlement yet.
1	C-20-Q	144	6.633	2001	2	0	0	2	Covered with asph. No problems.
MSE Abutment Backfill with Class 1 Backfill									
1	D-17-AP	52	11.167	1999	2	0	0	2	Look good.
1	E-16-QU	36	44.55	2000	2	0	0	2	Covered with asphalt. Look good.
Side by Side MSE (Class 1) and Flowfill Abutment Backfill, Chapter 4 for more details									
1	C-15-O	34		2001					
1	C-15-U	34		2001					
MSE Abutment Backfill with Class B Filter material, Project still in Progress									
1	Structures D-17-DN and D-17-DM								I-25 over CT RD 6
1	Structures D-17-CR and D-17-CT								I-25 over Ct. Rd 10
1	Structure D-17-DY								CT. Rd 8 over I-25

Table B.6. 2004 Performance Results of Flowfill and MSE Bridge Approaches in Region 1

Rating Based on Settlement	Structure Information				Rating based on Staff Bridge Inspection Records				Comments
	Bridge	Hiway	Mile Pt.	Built	# of Appro	fair	poor	good	
Flowfill Abutment Backfill									
1	F-15-CZ	74	3.031	1995	2	0	0	2	Asphalt cover the same elev. as bridge deck.
1	F-16-SB	285	244.1	1995	2	0	0	2	Some longitudinal cracks open 1/16".
1	G-17-DE	25	181.89	1995	2	0	0	2	Light random and longit. cracks in rear approach slab.
1	F-15-DA	74	3.03	1996	2	0	0	2	Covered with asphalt. No visible signs of settlement.
1	F-20-BY	36	100.24	1996	2	0	0	2	No visible signs of settlement at this time.
1	G-17-DF	25	181.85	1996	2	0	0	2	Couple of light longit. cracks in fwd. approach slab.
1	F-19-BH	70	307.41	1997	2	0	0	2	Light longit cracks in both.
1	F-19-BI	70	307.41	1997	2	0	0	2	Both show minor D cracks along jt with rdwy. Both show light longit cracks.
1	G-27-AE	24	445.52	1998	2	0	0	2	Covered with asphalt, no settling.
1	F-12-I	6	212.86	1999	2	0	0	2	Covered w/ asphalt. Look good.
1	F-15-AC	74	11.96	1999	2	0	0	2	Asphalt cover not cracked yet, therefore no settling.
1	F-15-BX	70	243.04	1999	4	2	0	2	Light to mod cracks perpendicular to skew spaced 10' +/- in WB and 5' +/- in EB.
1	F-15-BZ	70	243.04	1999	2	0	0	2	Many hairline to light diag. cracks in fwd. appr. slab. Appr. slab @ rear looks good.
1	F-15-CR	70	242.98	1999	2	0	0	2	Few lite longit. cracks.

1	F-17-CR	25	191.13	1999	2	0	0	2	Few light longit. cracks in both.
1	G-17-T	25	189.76	1999	2	0	0	2	Look good.
1.5	G-22-BX	71	100.92	1999	2	0	0	2	Hairline to lite cracks, perpendicular to skew at fwd. slab. 3" +/- dip @ fwd. appro. slab next to sleeper slab rt. lane. Looks to have been placed
1	E-14-BH	40	257.46	2000	2	0	0	2	Overlaid. Good transition.
1	F-15-AD	40	274.17	2000	2	0	0	2	Asphalt overlayed, no settling.
1	G-22-BY	24	376.56	2000	2	0	0	2	Roadway already low @ A-1 approach. Slight dip. Slab looks ok.
1	G-22-BZ	24	376.71	2000	2	0	0	2	Look good.
MSE Abutment Backfill									
3	E-19-Z	36	90.015	2000	2	0	0	2	Covered w/ asphalt. Look good.
1	F-19-M	36	93.301	2002	2	0	0	2	Looks Good.
Founders/Meadows Structure: Unique Structure discussed in Chapter 6									
1	G-17-T	25	189.76	1999	2	0	0	2	Looks Good.

Table B.7. 2004 Performance Results of Flowfill and MSE Bridge Approaches in Region 2

Rating based on Settlement	Bridge Information				Rating based on Staff Bridge Inspection Records				Comments
	Bridge	Hiway	Mile Pt.	Built	# of Appro	Fair	poor	good	
Flowfill Abutment Backfill									
1	I-18-BE	24	309.76	1994	2	0	0	2	Both have a few longitudinal cracks. Minor settling @ A2 SB.
1	I-17-JE	24	304.74	1995	2	0	0	2	Covered with asphalt. No sign of settlement.
1	I-17-JF	24	304.79	1995	2	0	0	2	Both covered with asphalt. No visible settlement. Couple short light longitudinal cracks.
1	N-17-BR	160	299.4	1995	2	0	0	2	Both covered with asphalt.
1	I-17-KZ	83	18.189	1996	2	2	0	0	6 +/-, light to 1/16" longitudinal cracks in both approach slabs.
1	K-18-GA	47	2.412	1996	2	0	0	2	Covered w/ asph. Same elevation as bridge deck. Look good.
1	L-21-DA	50	355.11	1997	2	0	0	2	Asphalt cover is smooth, no noticeable settling.
1	L-21-DB	50	358.46	1997	2	0	0	2	Covered with asphalt.
1	O-18-CN	25	23.195	1997	2	0	0	2	Asph. covered. No problems seen.
1	O-18-CO	25	22.345	1997	2	0	0	2	Overlaid. No problems seen.
1	K-18-GB	25	114.18	1998	2	0	0	2	Covered with asphalt. Look good.
1	K-18-GC	47	0.155	1999	2	0	0	2	Covered w/ asph. in roadway. Couple light longitudinal cracks in shoulder area @ #3. Exposed portion in sidewalk area has light scale & light random
1	P-20-T	160	366.03	1999	2	0	0	2	Covered with asphalt.
1	P-20-U	160	374.21	1999	2	0	0	2	Covered with asphalt.
1	I-15-AV	24	264.7	2000	2	0	0	2	Covered with asphalt. Look good.
1	I-17-NE	83	25	2001	2	0	0	2	Overlaid. Level with roadway & structure.

MSE Abutment Backfill									
1	I-18-AC	24	311	2000	2	0	0	2	Look good.
1	J-18-AI	85	132	2001	2	0	0	2	Covered w/ asphalt, but appear fine.
1	N-18-AA	25	47.179	2001	2	0	0	2	Asphalt covered. Asphalt has been milled some on both.
1	J-17-AA	115	31.285	2002	2	0	0	2	Look Good.
1	K-16-CH	115	18.881	2002	2	0	0	2	Asphalt overlaid.
1	K-18-GG	25	101.39	2002	2	0	0	2	3 to 4 lite longit cracks at right forward section.
1	L-20-A	96	84.25	2002	2	0	0	2	Look good no settling.
3	L-18-BD	Recently completed, see detailed investigation							

APPENDIX C. PHOTOS OF VARIOUS FLOWFILL AND MSE BRIDGE APPROACHES IN COLORADO

- **Bridge Approaches that Experienced Settlements (Figures C.1 to C.15)**
- **MSE Approaches with Satisfactory Performance (Figures C.16 to C.17)**



Figure C.1. A View from the South West Corner of the Salt Creek Bridge (Structure L-21-DB, Region 2)



Figure C.2. The Eastern Side of the Roadway Approaches of the I-70/I-225 Interchange (Structure E-17-SW in Region 6).



Figure C.3. Northern-Eastern Side of the Roadway Approaches of the I-70/I-225 Interchange (Structure E-17-SW in Region 6).



Figure C.4. The Eastern Side of the Bridge and Roadway Approaches of the I70/I-225 Interchange (Structure E-17-SW in Region 6).



**Figure C.5. A Settlement of 6” Between the Roadway and the Bridge Concrete Rail:
North-East Side of Structure E-17-SW in Region 6.**



Figure C.6. A view from Structure C-16-DK in Region 4 located along SH 287, 4 Miles North of Longmont



Figure C.7. The South Side of Buckley Over 1-76 (E-17-PQ, Region 6). This is a good Example of Bridge Bump Problem Generated at End of Construction.



Figure C.8. Photos of Structure E-17-PR in Region 6.



Figure C.9. Photo of Structure E-17-PS in Region 6



Figure C.10. Photos of Structure E-17-VR in Region 6



Figure C.11. Photo of Structure E-17-QA in Region 6



Figure C.12 Photo of Structure E-17-QA in Region 6



Figure C.13. Photos of Structure C-22-BT and C-21-BM in Region 4



Figure C.14. Photos of Structure G-22-BX in Region 1.



Figure C.15. Photos of Structure E-19-Z in Region 1 before Repair



Figure C.16. Photos of Structures C-15-U and C-15-O in Region 4 (Side by Side Flowfill and MSE Backfill with Excellent Performance).



Figure C17a. Photos of Bridge Structures in Region 2 Constructed with MSE Backfill



I-18-AC



L-20-A

Figure C17b. Photos of Bridge Structures in Region 2 Constructed with MSE Backfill



N-18-AA



K-18-GG

Figure C17c. Photos of Bridge Structures in Region 2 Constructed with MSE Backfill

REPORT PUBLICATION LIST
CDOT RESEARCH

- 2006-1 Evaluation of Quantm Software

- 2005-1 Castlewood Canyon Bridge
- 2005-2 Feasibility of Using Tirebales in Highway Applications
- 2005-3 Step-Up Phase I Report
- 2005-4 Colorado's Axial Load Tests on Drilled Shafts: Synthesis and Future Needs
- 2005-5 Detour Drainage Structure Design Procedure
- 2005-6 Density Profiling of Asphalt Pavements
- 2005-7 Hot Bituminous Pavement Gradation Acceptance Review of QC/QA Data 2000 Thorough 2003
- 2005-8 Hot Bituminous Pavement Voids Acceptance Review of QC/QA Data 2000 Through 2003
- 2005-9 Portland Cement Concrete Pavement Review of QC/QA Data 2000 Through 2003
- 2005-10 The Effects of Stream Restoration on the Population of An Obligate Riparian Small Mammal, The Preble's Meadow Jumping Mouse (*Zapus hudsonius preblei*)
- 2005-11 Design – Build Environmental Guidelines
- 2005-12 Roadside Vegetation Study
- 2005-13 Trinidad Lake Asphalt
- 2005-14 Synthesis of Noise Studies in Colorado
- 2005-15 2004 Tire/Pavement Noise Study
- 2005-16 Segregation in HMA Mines
- 2005-17 Review of F and t Test Results 2000 through 2004
- 2005-18 Hot Mix Asphalt, Gradation Acceptance, Review of QC/QA Data 2000 through 2004
- 2005-19 A Synthesis to improve the Design and Construction of Colorado's Bridge Anti-Icing Systems
- 2005-20 Interstate Asphalt Demonstration Project NH 0762-038 (Rubblization)
- 2005-21 Evaluation of the FHWA Traffic Noise Model (TNM) for Highway Traffic Noise Prediction in the State of Colorado

- 2004-1 Performance of Various Corrosion Protection Systems of Bridges in Colorado
- 2004-2 Evaluation of GFRP Deck Panel for the O'Fallon Park Bridge
- 2004-3 Long-Term Durability of Fiber-Reinforced Polymers (FRPs)
- 2004-4 Hot Bituminous Pavement, Gradation Acceptance, Review of QC/QA Data 2000 to 2002
- 2004-5 Colorado DOT Tire/Pavement Noise Study
- 2004-6 Cumulative Effects Assessment Modeling Along Colorado's North Front Range
- 2004-7 Identification of Appropriate Investment Levels to Improve and Maintain Seat Belt Usage Rate in the State of Colorado
- 2004-8 Drilled Shaft Design for Sound Barriers, Walls, Signs, and Signals
- 2004-9 Using RTD's Transit Vehicles to Develop Freeway Speed Maps for Colorado
- 2004-10 Cable Guard Rail – Interim Report
- 2004-11 Validity of Cluster Count Methodology

REPORT PUBLICATION LIST

CDOT RESEARCH

- 2004-12 Instrumentation and Field Testing of Thin Whitetopping and Revision of Existing Colorado Thin Whitetopping Design Procedures
- 2004-13 Recessed Striping in Concrete Pavement
- 2004-14 A Risk-Based Ranking System for CDOT Salt Pile Facilities
- 2004-15 Using Infrared Technology to Detect Hot or Defective Brakes on Trucks
- 2004-16 A Technical Review of the Colorado Department of Transportation's Pavement Management Activities
- 2004-17 Development of a Pavement Preventive Maintenance Program for the Colorado Department of Transportation

- 2003-1 Evaluation of Premature PCCP Longitudinal Cracking in Colorado
- 2003-2 Three-Dimensional Load Transfer of Colorado Type 7 and 10 Rails on Independent Moment Slab under High Test Level Impact Loads
- 2003-3 Assessment of the Cracking Problem in Newly Constructed Bridge Decks in Colorado
- 2003-4 Behavior of Fiber-Reinforced Polymer Reinforcement in Low-Temperature Environmental Climates
- 2003-5 Crack Reduction Strategies on a Pavement Warranty Project
- 2003-6 Improvement of the Geotechnical Axial Design Methodology for Colorado's Drilled Shafts Socketed in Weak Rocks
- 2003-7 Top Down Cracking
- 2003-8 Feasibility of Management System for Retaining Walls and Sound Barriers
- 2003-9 Identifying the Best Location Along Highways to Provide Safe Crossing Opportunities for Wildlife
- 2003-10 Mail Boxes and Mounting Systems
- 2003-11 Evaluation of a Bridge Deck with CFRP Prestressed Panels Under Fatigue Load Cycles
- 2003-12 Environmental Justice in Transportation Planning
- 2003-13 Studies on Use of HPC and FRP Reinforcement for the I225/Parker Road Interchange

- 2002-1 The Impact of CDOT Research
- 2002-2 Construction and Monitoring of Post-tensioned Masonry Sound Walls
- 2002-3 Whitetopping @ S.H. 121 Construction Report
- 2002-4 Corrosion Effects of Magnesium Chloride and Sodium Chloride on Automobile Components
- 2002-5 Cost of Sanding
- 2002-6 Local Road Need Assessment
- 2002-7 Environmental Justice Research Study
- 2002-8 Optimization of Concrete Pavement Mix Design in Colorado
- 2002-9 Development of Site Specific ESAL
- 2002-10 Slope Stabilization Methods
- 2002-11 In-Place Voids Monitoring of Hot Mix Asphalt Pavement
- 2002-12 Sampling Location Impact on Asphalt