

## Design Exception #1

### Tiered Walls Throughout the I-70 West Vail Pass Corridor

#### Design Exception Statement

Allow terraced walls on West Vail Pass to preserve the historic and scenic elements.

#### Process

A presentation was made to the Design Exception Issue Task Force on February 22, 2021. The Design Exception Issue Task Force has the same members as the Technical Team; therefore, Design Exception ITF Meeting #1 was held at the end of Technical Team Meeting #13.

#### The reasoning for this design exception request was:

- Terraced walls exist along the West Vail Pass corridor
- Terraced walls are a contributing feature to the historic district
- Terraced walls were originally built to reflect the terrain

The Design Exception ITF Team agreed to forward their recommendation to the Project Leadership Team supporting terraced walls on the West Vail Pass project was justified.

At the Project Leadership Team #8 held on March 26, 2021, the TT recommendation was presented, the PLT reviewed the process used and agreed that the CSS guidance had been followed.

#### Documentation for this Design Exception:

Design Exception Issue Task Force Meeting #1 presentation  
Design Exception ITF Meeting #1 meeting notes  
Project Leadership Team Meeting # 8 presentation  
Project Leadership Team Meeting #8 meeting notes



**COLORADO**  
Department of Transportation

**I-70 West Vail Pass Safety and  
Operations Improvements**



**PROJECT LEADERSHIP TEAM MEETING # 8**  
**MARCH 26, 2021**



## DESIGN EXCEPTION

Present and gain endorsement  
of the  
Design Exception Request for Tiered Walls

A Recommendation from the Technical Team



# DESIGN CRITERIA FOR TIERED WALLS

All roadway retaining walls over 12' in height will be installed below the elevation of the roadway.

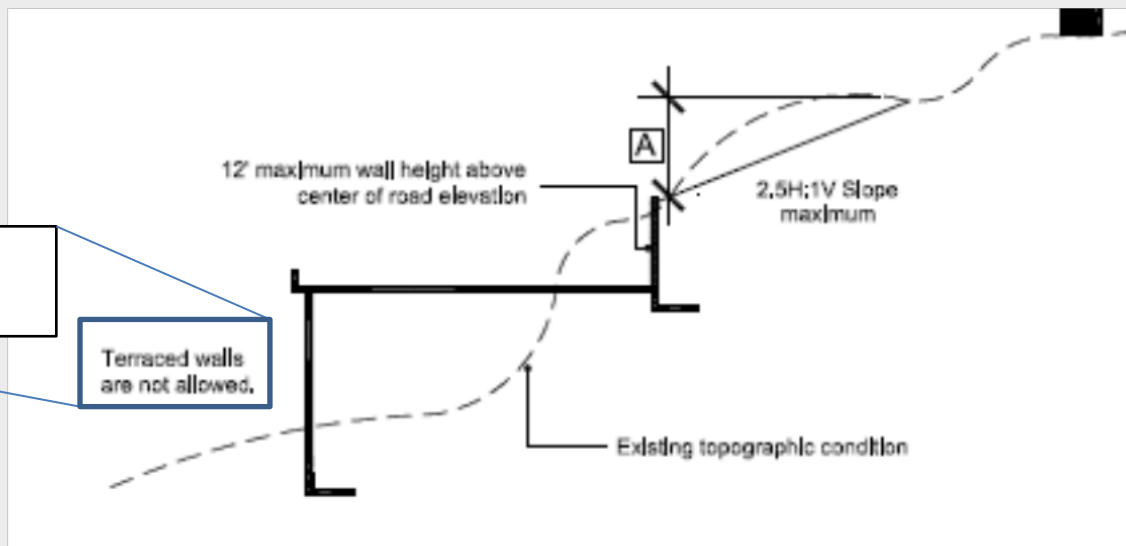





## CHALLENGE

### The West Vail Pass challenge in achieving the existing I-70 Engineering Design Criteria

- Terraced walls exist along the West Vail Pass corridor
- Terraced walls are a contributing feature to the historic district
- Terraced walls were originally built to reflect the terrain





# PROPOSED DESIGN EXCEPTION

**... Design exceptions may assist a designer in finding a transportation solution that balances impacts to scenic, historic, and culturally or environmentally sensitive areas while still providing for safety and mobility...**

1. Complementing surrounding physical characteristics
2. Enhancing safety
3. Increasing capacity
4. Reducing costs
5. Protecting the environment
- 6. Preserving historic and scenic elements**
7. Interfacing with multiple modes of transportation
8. Utilizing new technology or innovative approaches
9. Doing the right thing



## PROPOSED DESIGN EXCEPTION



Allow terraced walls on West Vail Pass to  
(6) preserve the historic and scenic elements.



## DESIGN EXCEPTION

Gain endorsement  
of the  
Design Exception Request for Tiered Walls  
Recommended by the Technical Team





## MEETING NOTES

<b>PROJECT:</b>	23982-23929 I-70 West Vail Pass Safety and Operations Improvements
<b>PURPOSE:</b>	Design Exception Meeting #1
<b>DATE HELD:</b>	February 22, 2021
<b>LOCATION:</b>	Online Google Meet Meeting
<b>ATTENDING:</b>	John Kronholm, Project Manager, CDOT Region 3 Karen Berdoulay, Resident Engineer, CDOT Region 3 Matt Figgs, CDOT Region 3 Patrick Chavez, CDOT I-70 Operations Joseph Bajza, CDOT Region 3 Maintenance Captain Jared Rapp, CSP Carole Huey, US Forest Service Greg Hall, Town of Vail Chad Salli, Town of Vail Dick Cleveland, Town of Vail Pete Wadden, Town of Vail Larissa Read, Consultant to ERWSD Michelle Cowardin, DNR Shannon Anderson, Bicycle Colorado Kevin Sharkey, ECO Trails Stephanie Gibson, FHWA Jeff Bellen, FHWA Shaun Cutting, FHWA Tracy Sakaguchi, Colorado Motor Carriers Association Jim Thomsen, Kiewit Randal Lapsley, R S & H Mary Jo Vobejda, Jacobs Jim Clarke, Jacobs Loretta LaRiviere, Jacobs
<b>COPIES:</b>	Attendees

### SUMMARY OF DISCUSSION:

#### 1. Introductions & Meeting Purpose

- a. Mary Jo confirmed the attendees at today’s meeting.
- b. Mary Jo said the purpose and goal for today’s meeting is to present and gain endorsement of the Design Exception Request for Tiered Walls.

#### 2. Review of the Design Exception for Tiered Walls

- a. Mary Jo noted the criteria for tiered walls is in the I-70 Mountain Corridor Design Criteria. It is specifically for the I-70 Mountain Corridor. The I-70 Mountain Corridor Design Criteria states that retaining walls over twelve feet in height must be installed below the elevation of the roadway. The designers are working to keep the walls no higher than twelve feet.
- b. Mary Jo said the I-70 Mountain Corridor Design Criteria states that terraced walls are not allowed. Terraced walls exist along the West Vail Pass Corridor. These walls were originally built to reflect the terrain and they are a contributing feature to the historic district.



- c. Mary Jo explained design criteria is put together as the way to best meet the goals the entity is trying to achieve. As time goes on and techniques evolve, there can be different ways to meet the goal. It is important to go back to the original design criteria and look at what was the goal. The I-70 Mountain Corridor goal was to be light on the land and reflect the character of the land, to fit into the landscape.
- d. Mary Jo presented the process within the Context Sensitive Solutions Design Criteria and I-70 Mountain Corridor Guidance that allows for design exceptions: *Design exceptions may assist a designer in finding a transportation solution that balances impacts to scenic, historic, and culturally or environmentally sensitive areas while still providing for safety and mobility...*
  1. *Complementing surrounding physical characteristics*
  2. *Enhancing safety*
  3. *Increasing capacity*
  4. *Reducing costs*
  5. *Protecting the environment*
  6. ***Preserving historic and scenic elements***
  7. *Interfacing with multiple modes of transportation*
  8. *Utilizing new technology or innovative approaches*
  9. *Doing the right thing*
- e. Mary Jo said #6 clearly applies to this particular category. Therefore, we are proposing there be a design exception that would allow terraced walls above the transportation facility on West Vail Pass to preserve the historic and scenic elements of the original design.
  1. Greg asked for confirmation that this Design Exception is for whether you can do the terraced walls, not how they are constructed, and the Aesthetics ITF will provide further guidance on the walls.
    - i. Mary Jo confirmed the Aesthetics ITF will give feedback on the look, height, and features of the walls.
    - ii. Mary Jo said other projects east of the divide have requested design exceptions for terraced walls above the transportation facility and in some places the exception was approved, and the terraced walls were built.
    - iii. She noted we are not saying we would exceed the twelve feet wall height, we are saying that each wall terrace would be no more than twelve feet. The Aesthetic Guidelines could limit that even more.
  2. Greg asked how do we get the balance of building terraced walls or refining grading?
    - i. Mary Jo said this is an overarching request for an exception so we have the option for terraced walls above the transportation facility, but it doesn't mean we would always use this option. Grading or using natural materials will be considered in the design at all locations along the Pass.



- ii. Karen confirmed this design exception request will not override the Aesthetic Guidelines and balancing the walls with grading the natural topography will be done where possible. It makes sense to have this request approved so we can replace the walls that are already there or build more walls where they are needed.
3. Greg said when you first talked about the design exceptions in the EA there was an area in West Vail that would have very high walls. It seems like without this exception you would have to build the roadway platform or do something like the Glenwood Canyon cantilever, but it is possible it could be terraced. Maybe there is a way different to build it that is much more structural with not as much grading and walls.
  - i. Karen said this was in the MM 182 area and it was related to how we were going to build the bridges in that area but we are not developing design for anything that is not in the INFRA Grant project. This exception will be used for all future projects, so it makes sense to put tiered walls back where there already are some on the Corridor.
  - ii. John said it depends on how the project is phased or not phased. Even in that area we looked at all the different design exceptions such as maintaining median width or walls versus cut. If you didn't want a wall there and you didn't have a design exception, I-70 would have to be rerouted through a part of the Town of Vail to get rid of the wall. He stressed we are not developing design and solutions in that area now because we are focusing on what is in the INFRA Grant. The Aesthetic Guidelines are being prepared for all of Vail Pass and this design exception would be for all of Vail Pass.
4. Greg said he thinks we are going down the right path. When you start to get into Aesthetic Guidelines for the entire Pass, terraced walls will be included. Even though you have the design exception, there may be other alternatives that you may have to look at to avoid impacts to other projects in the future that may not be in the EA.
  - i. Karen said Greg is correct, the Aesthetic Guidelines will be for the entire Corridor and will apply to all future projects.
  - ii. Karen said it is important to remember the EA was a 10% design and now that we are refining the design of the INFRA Grant portion of the work, we are trying to balance all the core values of the project. We are coming to you with major changes from the EA design.
5. Greg said it makes sense to approve this exception and asked if we needed a motion for approval.
  - i. Mary Jo asked if anyone had objections to the proposal and there were none.



- ii. Mary Jo said it is considered approved by the Technical Team and will be moved forward to the PLT Meeting on March 26<sup>th</sup>.





**COLORADO**  
Department of Transportation

**I-70 West Vail Pass Safety and  
Operations Improvements**



**PROJECT LEADERSHIP TEAM MEETING # 8**  
**MARCH 26, 2021**



## DESIGN EXCEPTION

Present and gain endorsement  
of the  
Design Exception Request for Tiered Walls

A Recommendation from the Technical Team





# DESIGN CRITERIA FOR TIERED WALLS

All roadway retaining walls over 12' in height will be installed below the elevation of the roadway.

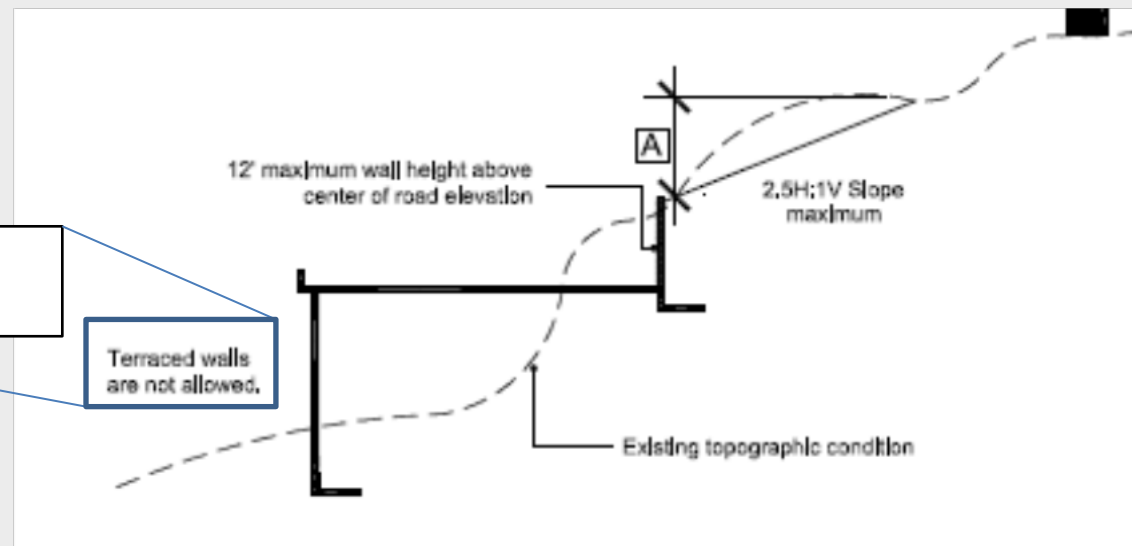

Terraced Walls are not allowed

Terraced walls are not allowed.



## CHALLENGE

### The West Vail Pass challenge in achieving the existing I-70 Engineering Design Criteria

- Terraced walls exist along the West Vail Pass corridor
- Terraced walls are a contributing feature to the historic district
- Terraced walls were originally built to reflect the terrain





# PROPOSED DESIGN EXCEPTION

**... Design exceptions may assist a designer in finding a transportation solution that balances impacts to scenic, historic, and culturally or environmentally sensitive areas while still providing for safety and mobility...**

1. Complementing surrounding physical characteristics
2. Enhancing safety
3. Increasing capacity
4. Reducing costs
5. Protecting the environment
- 6. Preserving historic and scenic elements**
7. Interfacing with multiple modes of transportation
8. Utilizing new technology or innovative approaches
9. Doing the right thing



## PROPOSED DESIGN EXCEPTION



Allow terraced walls on West Vail Pass to  
(6) preserve the historic and scenic elements.



## DESIGN EXCEPTION

Gain endorsement  
of the  
Design Exception Request for Tiered Walls  
Recommended by the Technical Team



## MEETING NOTES

<b>PROJECT:</b>	23982-23929 I-70 West Vail Pass Safety and Operations Improvements
<b>PURPOSE:</b>	Project Leadership Team (PLT) Meeting #8
<b>DATE HELD:</b>	March 26, 2021
<b>LOCATION:</b>	Online Google Meet Meeting
<b>ATTENDING:</b>	John Kronholm, Project Manager, CDOT Region 3 Karen Berdoulay, Resident Engineer, CDOT Region 3 Rob Beck, Program Engineer, CDOT Region 3 Matt Figgs, CDOT Region 3 Lisa Schoch, CDOT Historian Greg Hall, Town of Vail Ben Gerdes, Eagle County Dick Cleveland, Town of Vail Stephanie Gibson, FHWA Jeff Bellen, FHWA Jim Thomsen, Kiewit Mark Gutknecht, Kiewit Randal Lapsley, R S & H Mary Jo Vobejda, Jacobs Loretta LaRiviere, Jacobs
<b>COPIES:</b>	Attendees

### SUMMARY OF DISCUSSION:

#### 1. Design Exception Recommendation for Tiered Walls

- a. Mary Jo said this is the part of the presentation when we want to engage you and ensure you understand the Design Exception for Tiered Walls that is being requested. We developed this Design Exception Request with our TT and had a robust discussion around it which resulted in them endorsing the Design Exception to send on to the PLT for approval.
- b. The I-70 Design Criteria states tiered walls are not allowed. They have been used on other portions of the Mountain Corridor and we checked with Vanessa Henderson/CDOT whose role is to ensure design consistency throughout the Mountain Corridor. She told us that exceptions for terraced walls have been allowed in other locations on I-70.
- c. CSS Guidelines state that design exceptions may assist a designer in finding a transportation solution that balances impacts to scenic, historic, and culturally or environmentally sensitive areas while still providing for safety and mobility.
- d. West Vail Pass already has tiered walls that are a contributing feature to the historic district, and they were originally built to reflect the terrain. The challenge is that we want to recreate these walls in some new locations, and we need the Design Exception to build tiered walls.

Greg commented there are two issues with this design exception. One is 12' tall height above the surface and then the tiering. The tiered walls are





historic, so he agrees that we should build tiered walls. It's notable that Almost all walls except for three small locations are fill walls. These are interior to the surface but outside the travel lanes. In this situation he thinks there are only three cut walls above the roadway surface outside the right of way between Vail and Copper Mountain. He thinks that's why the original I-70 discussion of walls no higher than 12' above the roadway surface is in the Design Criteria.

The original walls are outside the travel lanes toward the edges of the right of way or the forest. That's why when he thinks you look at the overall I-70 Design Criteria Guidelines, they talk about only minimizing walls to a 12' height on the outside above the roadway shoulder. There are some walls on the interior between the two lanes that are of significant height. You might say it's above, in this case, the westbound lane and that's more than 12' high but he thinks it was all part of the built environment.

Mary Jo said they have started to address wall heights in the Aesthetic Guidelines for walls that are above the road surface that If you are going to see a lot of the wall, there will be height restrictions. We have started to deal with this because it is very specific to the type of wall we are building. This Design Exception proposal is consistent with the Design Guidelines as far as the height of the walls.

Karen thanked Greg for his insight, and asked Greg to confirm that he supported the tiered walls.

Greg said he supports the Design Exception Request for Tiered Walls to meet historic context of existing walls.

Dick said he is supportive of the Design Exception but wants to make it clear to the designers that this exception is not there to make their jobs easier, it's to accomplish what we're trying to do which is to match the existing and do the best we can to improve what we have out there.

Lisa said, as the person interested in historic preservation of the Corridor, she thinks it's always hard to balance trying to improve the transportation facilities and maintain historic integrity. But she endorses the tiered walls because it is important to the design and the aesthetics of the district.

Jeff Bellen/FHWA supports the design exception.

Ben Gerdes said Eagle County supports the design exception.

Karen said we appreciate your endorsement of the Tiered Walls Design Exception. We will continue to work hard to seek feedback from our stakeholders as we progress through design and try to find the balance of our core values through our refinements.