

-PEDESTAL POLE CONFIGURATIONS-

INDEX

1. PEDESTAL POLE INSTALLATION
2. PEDESTAL POLE FOUNDATION DETAILS

GENERAL NOTES

1. ALL PEDESTAL POLE STEEL SHALL BE ASTM A53 GRB AND SHALL BE HOT DIP GALVANIZED INSIDE AND OUTSIDE ACCORDING TO ASTM A123.
2. MOUNTING HARDWARE FOR EACH TRAFFIC SIGNAL WILL BE FURNISHED BY THE MANUFACTURER, INCLUDING POLE PLATES FOR SIDE POLE MOUNTING.
3. PEDESTAL POLES SHALL HAVE A FRANGIBLE BASE: AKRON FOUNDRY TB2-17 OR APPROVED EQUAL.
4. ALL POLES, PEDESTALS AND CABINETS SHALL BE PLACED A MINIMUM OF 2 FEET OFF THE ROADWAY MEASURED FROM THE EDGE OF SHOULDER OR FACE OF CURB.
5. 12-12-12 TRAFFIC SIGNAL FACES FOR RAMP METERING LOCATIONS SHALL BE ALUMINUM TYPE.
6. TWO-SECTION 12" RED AND GREEN SIGNAL HEADS SHALL BE "ANGLED IN" AND SHALL BE EQUIPPED WITH VISORS THAT MAY BE POSITIONED TO EITHER SIDE OF THE LENS, ALLOWING ONLY THE FIRST MOTORIST BEHIND THE STOP BAR TO SEE THE SIGNAL INDICATION.
7. REGULATORY SIGNING SHALL BE AS SHOWN ON THE PLANS. 24R10-6a FOR LEFT SIDE POLE INSTALLATIONS SHALL CONTAIN A RIGHT-POINTING ARROW. 24R10-6a FOR RIGHT SIDE POLE INSTALLATIONS SHALL CONTAIN A LEFT-POINTING ARROW. TYPICAL SPECIAL SIGN MESSAGES ARE "1 VEHICLE PER GREEN" FOR SINGLE-LANE METERED RAMPS, AND "1 VEHICLE PER GREEN EACH LANE" FOR TWO-LANE METERED RAMPS.
8. ALL SIGNAL HEADS SHALL BE APPROVED LED TYPE.
9. IF THE PLACEMENT OF A PEDESTRIAN PUSH BUTTON ASSEMBLY ON A TRAFFIC SIGNAL MAST POLE WILL NOT BE WITHIN EASY REACH BY PEDESTRIANS (10" OR LESS AND UNOBSTRUCTED IN ACCORDANCE WITH THE AMERICANS WITH DISABILITIES ACT), THEN A SEPARATE PEDESTRIAN PUSH BUTTON POST ASSEMBLY (PPBPA) SHALL BE INSTALLED WITHIN EASY REACH. THE PPBPA SHALL MEET THE PROVISIONS FOUND IN CDDT STANDARD PLAN S-614-9 AND "SECTION 4E.08 THROUGH 4E.13 - PEDESTRIAN DETECTORS" IN THE 2009 MUTCD WITH REVISIONS 1 AND 2.

POLE AND CAISSON INFORMATION

MEMBER	ATTRIBUTES AND LOADS	TRAFFIC SIGNAL POLE	RAMP METERING POLE
POLE	SIZE	6" ϕ SCH 40	4" ϕ SCH 40
	SERVICE MOMENT	14.72 k.ft.	4.23 k.ft.
	SERVICE SHEAR	0.97 kip	0.45 kip
CAISSON	SIZE	18" ϕ	18" ϕ
	ULT. MOMENT	20.55 k.ft.	5.90 k.ft.
	ULT. SHEAR	1.36 kip	0.63 kip

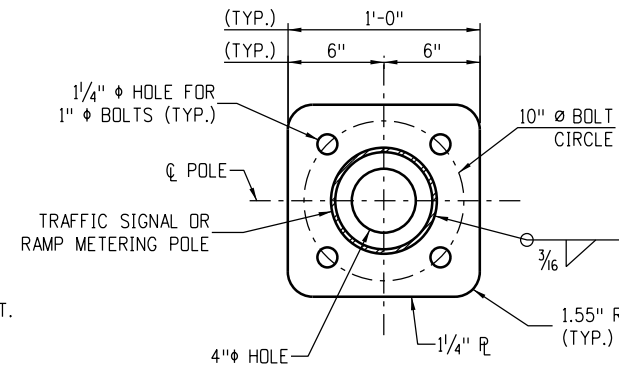

BASE PLATE

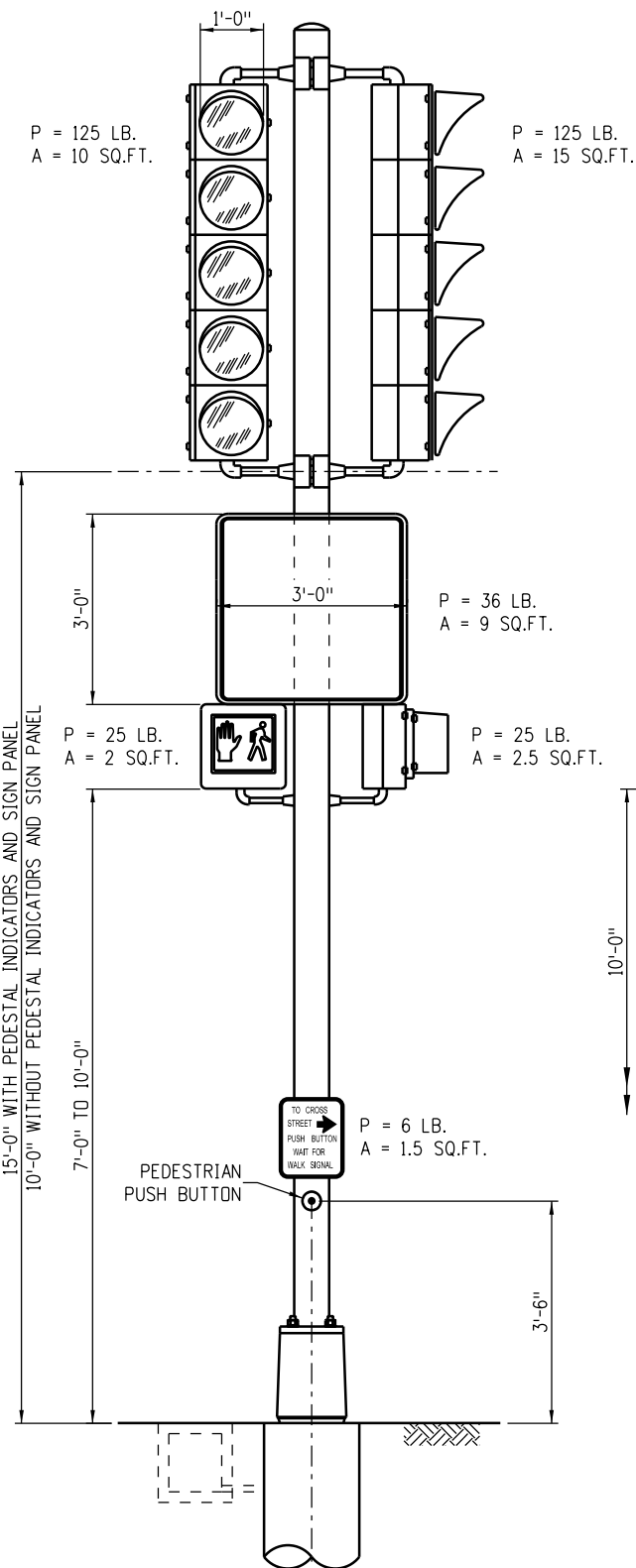

**TRAFFIC SIGNAL
PEDESTAL POLE DETAIL**

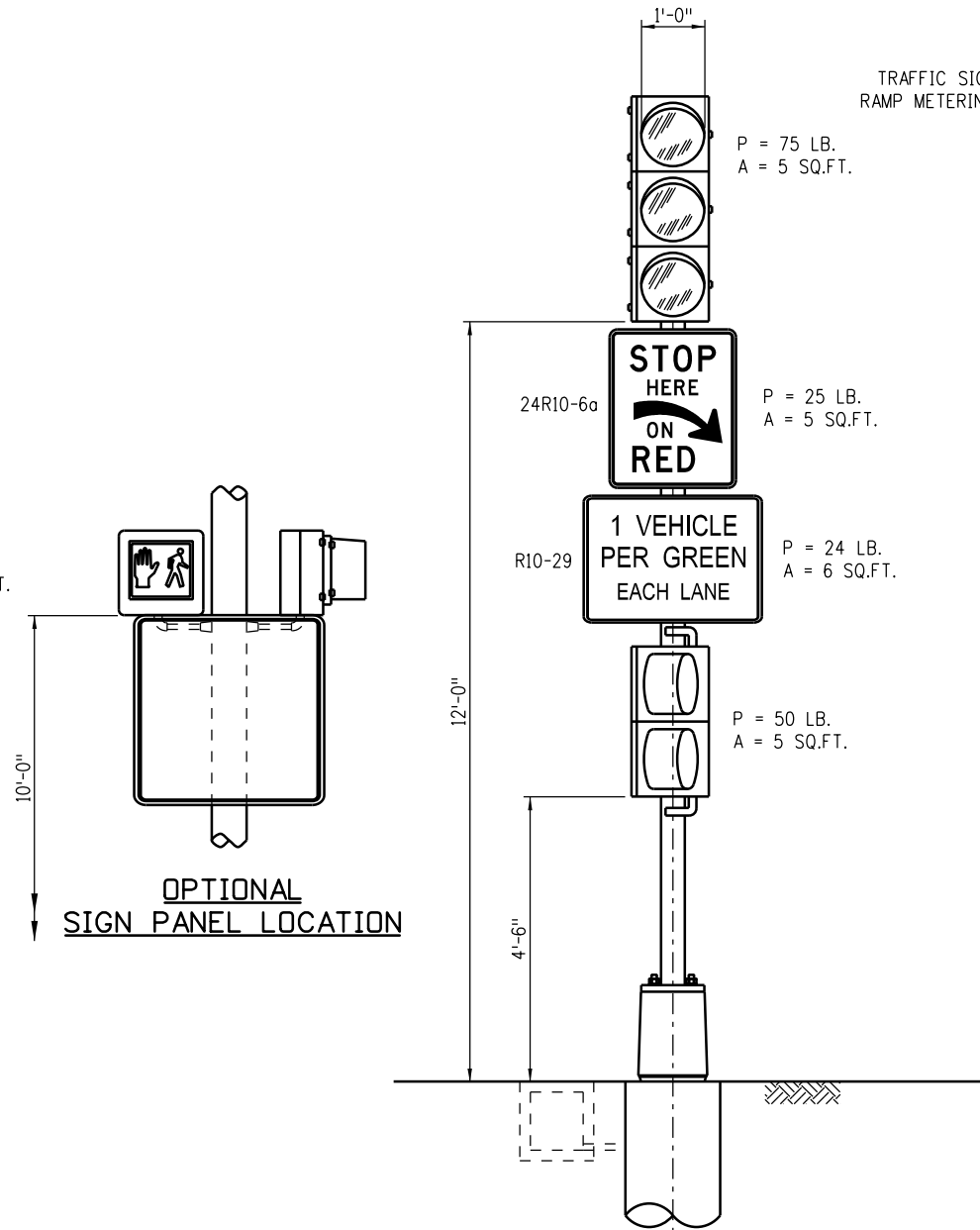

**RAMP METERING
PEDESTAL POLE DETAIL**
(LEFT SIDE INSTALLATION SHOWN)

(R-X)
(R-X)
(R-X)
(R-X)

Computer File Information

Creation Date: 07-04-12 Initials: LAW
 Last Modification Date: 08-08-13 Initials: DWS
 Full Path: www.codot.gov/library/traffic/traffic-standards/2012-s-standard-plans
 Drawing File Name: S-614-44 (1 of 2).dgn
 CAD Ver.: MicroStation V8 Scale: Not to Scale Units: English

Sheet Revisions

Date:	Comments

Colorado Department of Transportation



2829 W Howard Place
 Denver, Colorado 80204
 Phone: 303-757-9543 FAX: 303-757-9219

Safety & Traffic Engineering KCM/RLO

PEDESTAL POLE SIGNALS

Issued By: Safety & Traffic Engineering Branch July 4, 2012

STANDARD PLAN NO.

S-614-44

Sheet No. 1 of 2

-PEDESTAL POLE FOUNDATION DETAILS-

FOUNDATION NOTES

1. CAISSON CONCRETE SHALL BE AIR ENTRAINED CLASS BZ IN ACCORDANCE WITH SECTION 503 OF THE STANDARD SPECIFICATIONS.
2. REINFORCING STEEL SHALL BE GRADE 60 IN ACCORDANCE WITH SECTION 602 OF THE STANDARD SPECIFICATIONS.
3. ALL REINFORCING STEEL SHALL BE NON COATED.
4. CAISSON CONCRETE MUST HAVE A MINIMUM COMPRESSIVE STRENGTH OF 2,700 PSI BEFORE INSTALLING THE PEDESTAL POLE; VERIFY CONCRETE STRENGTH WITH MATURITY METER.
5. CAISSONS SHALL BE PLACED AGAINST UNDISTURBED EARTH.

DESIGN DATA

CAISSON CONCRETE:
 CLASS BZ CONCRETE: $f'c$ = 4,000 psi
 REINFORCING STEEL: f_y = 60,000 psi

DESIGN WIND SPEED = 90 mph

THE DESIGNS HEREIN ASSUME THAT THE PEDESTAL POLES ARE INSTALLED WITHIN THE ROADWAY PRISM WITH THE FOLLOWING PARAMETERS:

MEDIUM DENSE COHESIONLESS SOIL:
 SOIL DENSITY, γ = 110 pcf
 SOIL ν ANGLE = 30°
 SF = 1.25 FOR FLEXURAL RESISTANCE

MEDIUM STIFF COHESIVE SOIL:
 SOIL DENSITY, γ = 110 pcf
 SOIL COHESION = 750 psf
 SF = 1.25 FOR FLEXURAL RESISTANCE

CONTACT THE ENGINEER IF ANY OF THE FOLLOWING SOIL CONDITIONS ARE ENCOUNTERED DURING DRILLING:

- (A) SIGNALS WILL NOT BE INSTALLED WITHIN THE ROADWAY PRISM.
- (B) THE SOIL HAS A HIGH ORGANIC CONTENT OR CONSISTS OF SATURATED SILT AND CLAY.
- (C) THE SITE WON'T SUPPORT THE WEIGHT OF THE DRILLING RIG.
- (D) THE FOUNDATION SOILS ARE NOT HOMOGENOUS.
- (E) FIRM BEDROCK IS ENCOUNTERED.

UNFACTORED GROUP LOAD II COMBINATION LOADS FOR THE DESIGN OF POLES WERE GENERATED WITH THE STANDARD SPECIFICATIONS FOR STRUCTURAL SUPPORTS FOR HIGHWAY SIGNS, LUMINAIRES, AND TRAFFIC SIGNALS, 5TH EDITION INCLUDING THE 2010 & 2011 INTERIMS.
 LOAD FACTORS FOR GENERATING ULTIMATE CAISSON LOADS ARE FOR THE STRENGTH III LOAD COMBINATION AS SPECIFIED IN THE 6TH EDITION OF THE AASHTO LRFD BRIDGE DESIGN SPECIFICATIONS.

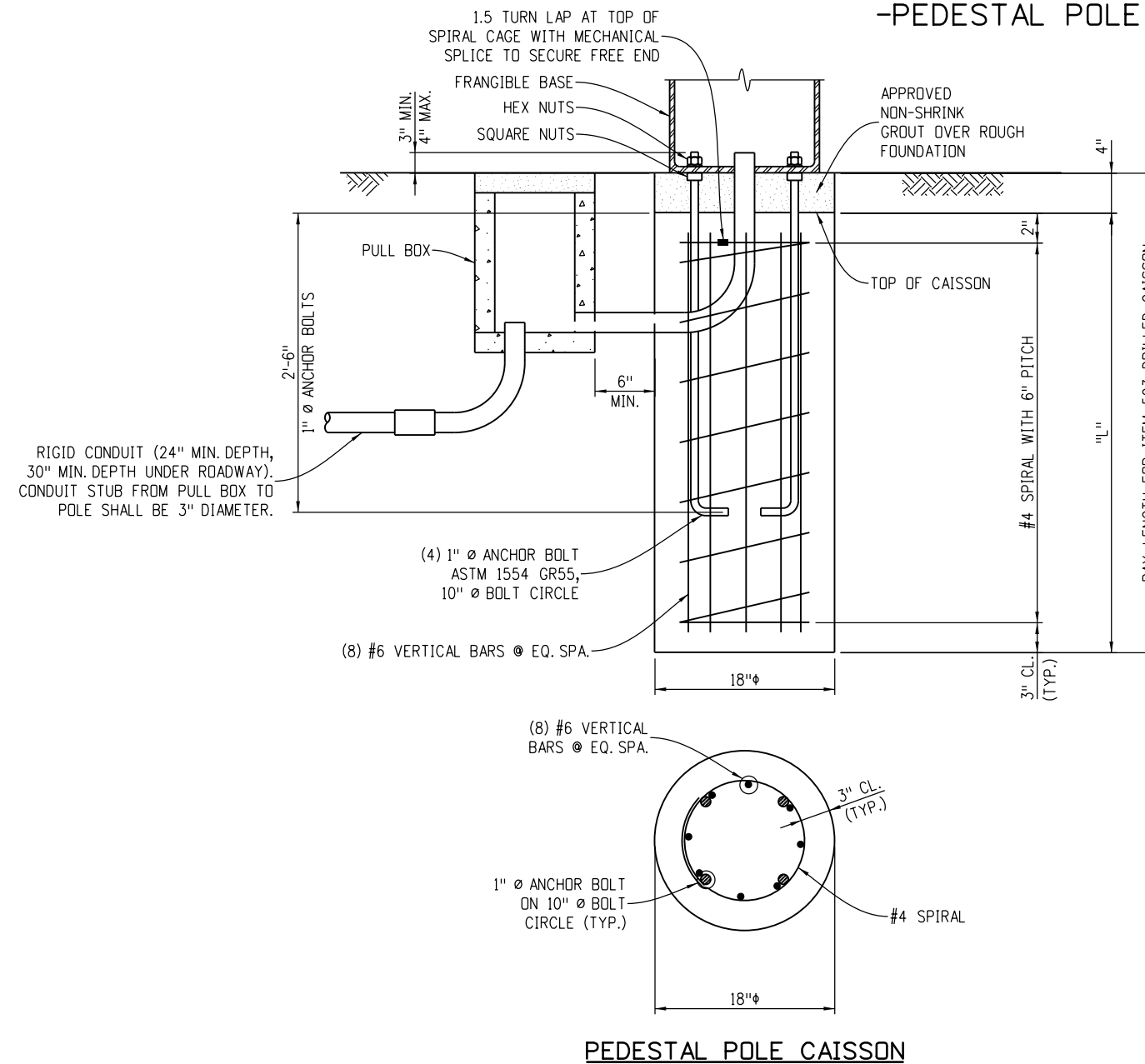

CAISSON DATA TABLE

	TRAFFIC SIGNAL PEDESTAL POLE CAISSON	RAMP METERING PEDESTAL POLE CAISSON
"L"	4'-8"	3'-2"
PAY LENGTH	5'-0"	3'-6"

Computer File Information		Sheet Revisions	Colorado Department of Transportation	PEDESTAL POLE SIGNALS	STANDARD PLAN NO.
Creation Date: 07-04-12	Initials: LAW	Date: 06/17/16	2829 W Howard Place Denver, Colorado 80204 Phone: 303-757-9543 FAX: 303-757-9219	Issued By: Safety & Traffic Engineering Branch July 4, 2012	S-614-44 Sheet No. 2 of 2
Last Modification Date: 08-08-13	Initials: DWS	REVISIONS			
Full Path: www.codot.gov/library/traffic/traffic-standards/2012-s-standard-plans					
Drawing File Name: S-614-44 (2 of 2).dgn					Safety & Traffic Engineering
CAD Ver.: MicroStation V8	Scale: Not to Scale	Units: English	KCM/RLO		