

**Push Button and Sign Detail**

**Pedestrian Push Button**

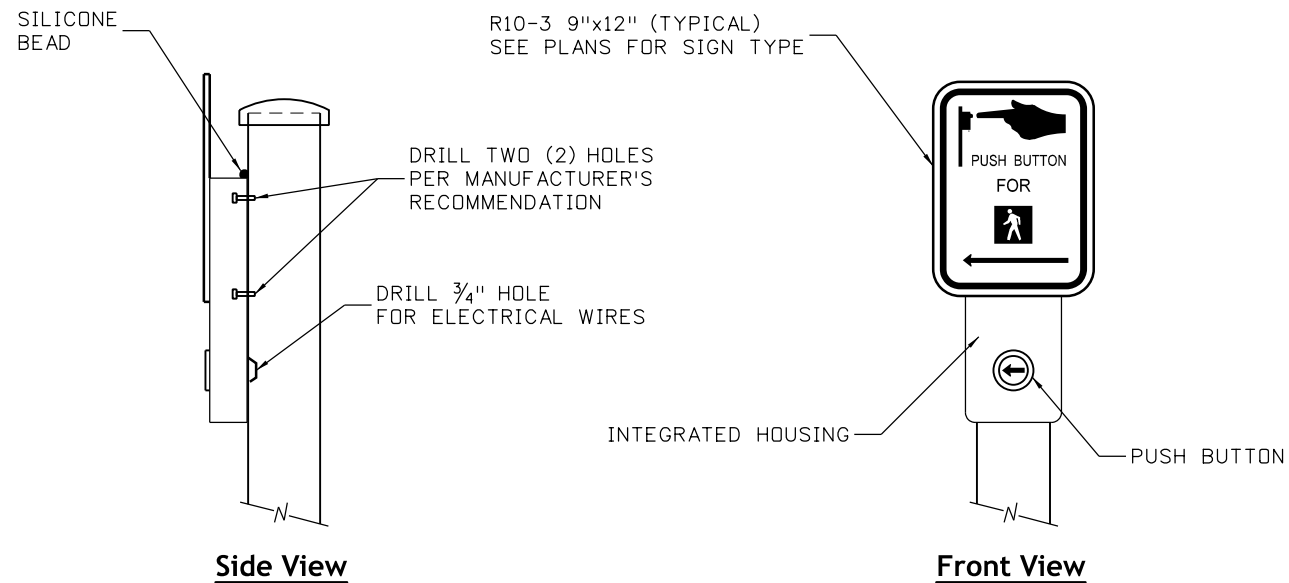

**Integrated Housing Detail**

**Accessible Pedestrian Signal**

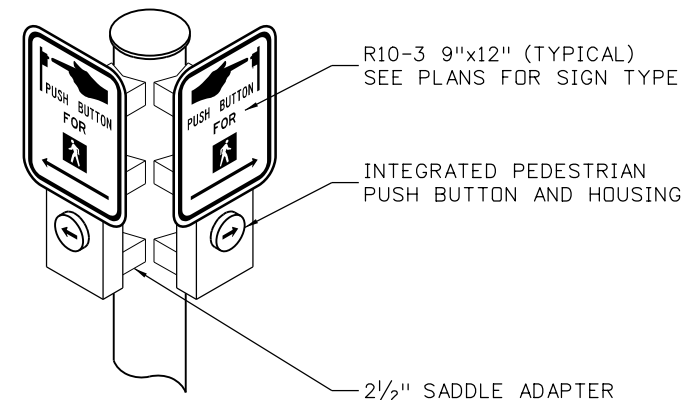

**Dual Mount Detail  
(Alternate)**

**General Notes**

1. Pedestrian push button shall utilize piezo switch technology. The actuator color shall contrast with the housing or mounting. If a tactile arrow is provided, the tactile arrow shall be part of the actuator and shall contrast with the background.
2. Accessible pedestrian signal shall integrate a pedestrian push button into its housing. The actuator color shall contrast with the housing and shall vibrate during the walk interval. A contrasting tactile arrow shall be part of the actuator.
3. Accessible pedestrian signal dual mount applications shall include the required amount of 2½-inch saddle adapters and all hardware to facilitate the work in addition to the items identified in Note 2. The saddle adapter hardware is specific to the installed accessible pedestrian signal.
4. Pedestrian push button post assembly shall include aluminum shaft, push button base, hardware, any additional mounting/saddle brackets not identified in Notes 1 and 3, wiring, concrete, and all other items necessary to complete the work.
5. Signs shall be included in the cost of either "Pedestrian Push Button" or "Accessible Pedestrian Signal" (to which the sign is installed for).
6. Pedestrian push button, accessible pedestrian signal, and the location of the pedestrian push button post assembly shall be ADA compliant and meet the provisions found in Sections 4I.05 through 4I.06 of the MUTCD.
7. Install all signs, pedestrian push buttons, and accessible pedestrian signals per the Manufacturer's installation recommendations.
8. Apply anti-seize compound to all bolts prior to assembly.
9. Apply a bead of 100% silicone sealant along the push button unit where it comes in contact with the 4" aluminum shaft (or saddle brackets) and along the push button base where it comes in contact with the concrete.
10. Every effort should be made to install pedestrian push buttons (or accessible pedestrian signals) on separate poles. The "Dual Mount Detail" should only be utilized when all other efforts have been exhausted and must, in-turn, adhere to Notes 12 and 13 found on Sheet 4 of this standard.
11. Accessible pedestrian signal request forms, which are requested locally due to a visual impairment, can be obtained by reaching out to CDOT's Civil Rights & Business Resource Center.

Computer File Information	
Creation Date:	01/22/2020
Created By:	TDN
Last Modification Date:	07/01/26
Last Modified By:	NRR
CAD Ver.:	ORD 10.12 Scale: Not to Scale Units: English

Sheet Revisions	
Date:	Comments

**Colorado Department of Transportation**  
**Traffic Safety & Engineering Services**  
 2829 West Howard Place  
 Denver, CO 80204  
 EB

**Pedestrian Push Button  
 Post Assembly Details**  
 Issued by the Traffic Safety & Engineering Services: July 01, 2026

Standard Plan No.
<b>S-614-45</b>
Standard Sheet No. 1 of 6
Project Sheet Number:

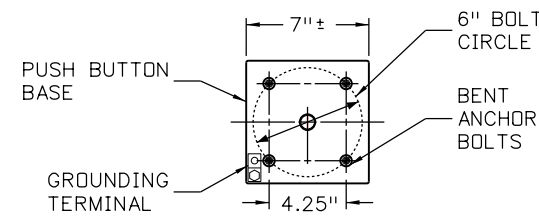

**Anchor Rod Placement**

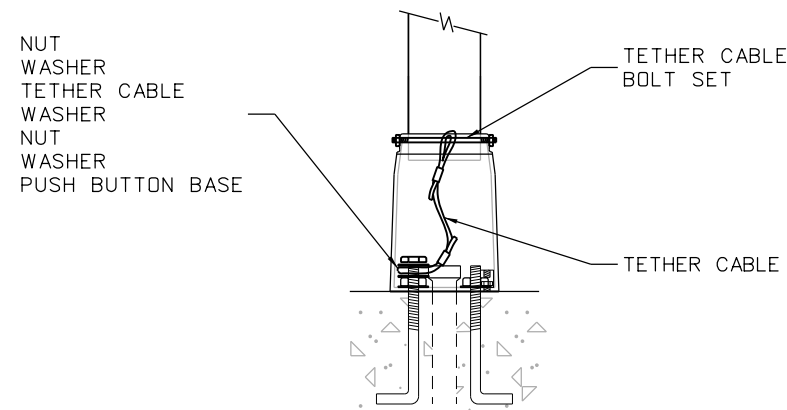

**Tether Detail**

**Notes**

1. Posts shall be Schedule 40 aluminum and painted (if necessary) with the color specified in the plans according to the Manufacturer's recommendations.
2. Approved push button bases are listed on CDOT's Approved Products List website under 'Traffic Control/Signal'.
3. All electrical conduit shall be PVC Schedule 80.
4. Grounding wire shall be #10 AWG (minimum) copper and laid in the 2 inch PVC conduit. Terminate grounding wire to the signal grounding system in pullbox.
5. Post assemblies shall be tethered to an anchor bolt. Follow the Manufacturer's installation recommendations.
6. Apply anti-seize compound to all bolts prior to assembly.
7. Bent anchor bolts shall be embedded into new concrete.
8. Concrete shall be Class B or match the proposed sidewalk/curb concrete Class Type as specified in the plans.

**Anchor Rod Mounting Hardware**

- 4 ea - 5/8" x 8" A449, Type 1, Galvanized Bent Anchor Bolt
- 4 ea - 5/8" A563DH Heavy Hex, Galvanized Hex Nut
- 4 ea - 5/8" F436 Washer

\* Additional washers and hex nuts may be required to properly meet grounding and tethering requirements.

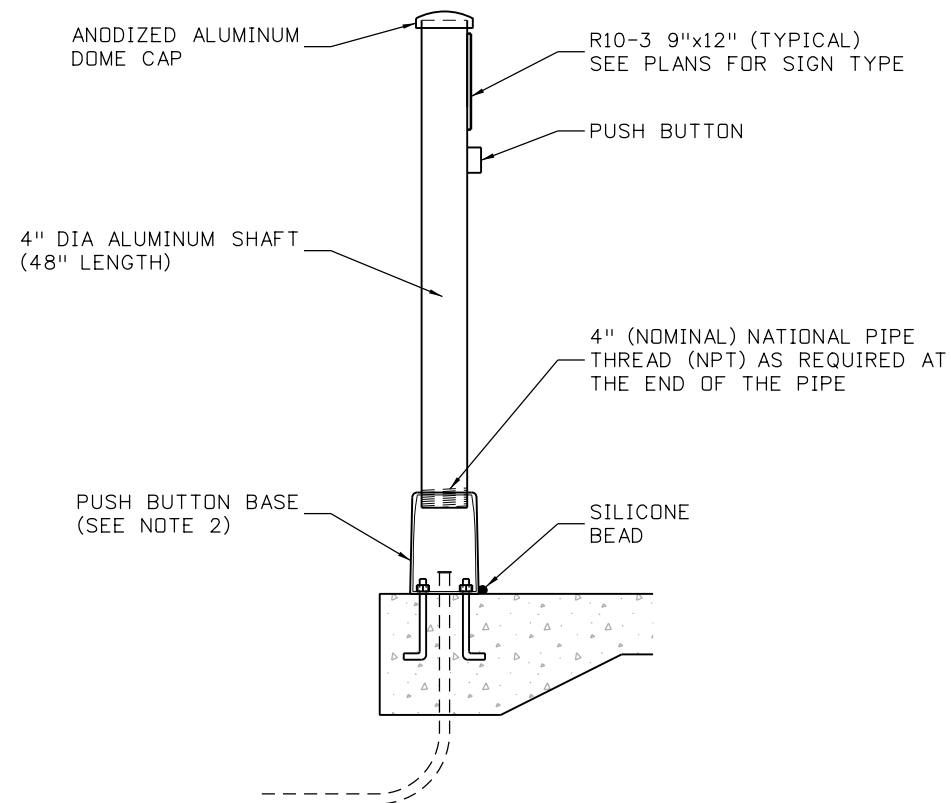

**Pedestrian Push Button Post Assembly**

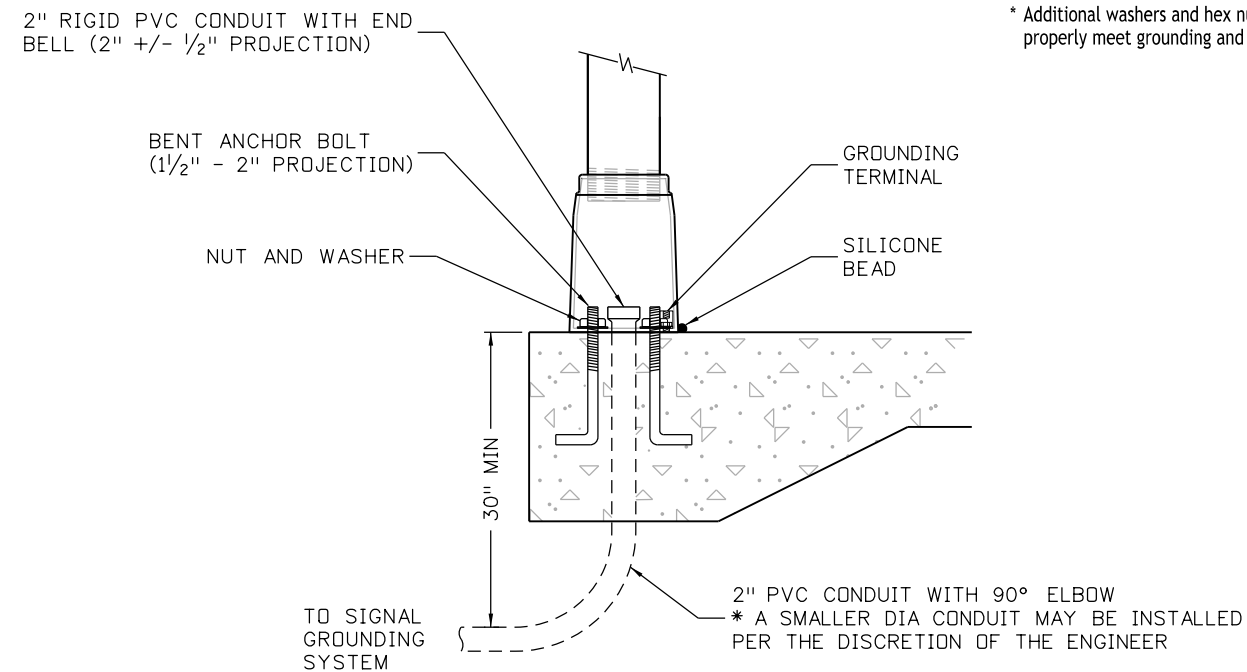

**Pedestal Base Detail**

<b>Computer File Information</b>		<b>Sheet Revisions</b>		<b>Colorado Department of Transportation</b>  <b>Traffic Safety &amp; Engineering Services</b> 2829 West Howard Place Denver, CO 80204 EB	<b>Pedestrian Push Button Post Assembly Details</b>	<b>Standard Plan No.</b>
Creation Date: 01/22/2020		Date:	Comments:			<b>S-614-45</b>
Created By: TDN						Standard Sheet No. 2 of 6
Last Modification Date: 07/01/26						Project Sheet Number:
Last Modified By: NRR						
CAD Ver.: ORD 10.12 Scale: Not to Scale Units: English					Issued by the Traffic Safety & Engineering Services: July 01, 2026	

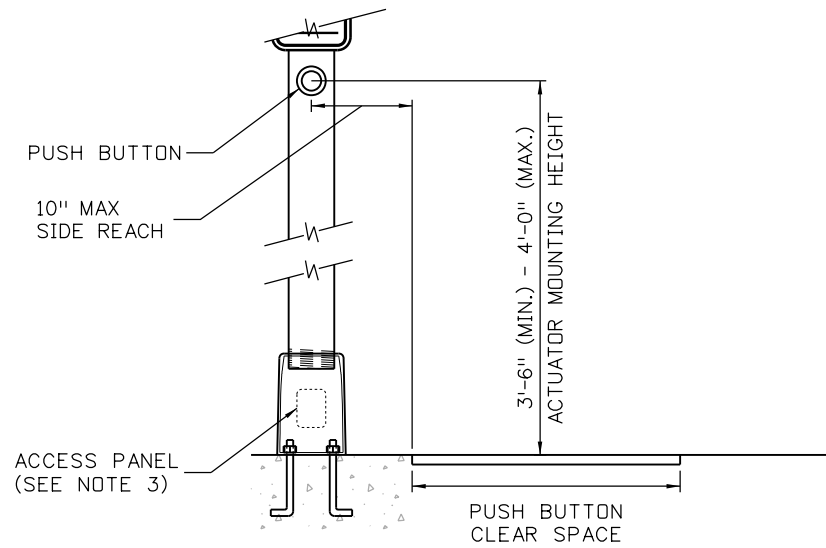

**Front View**

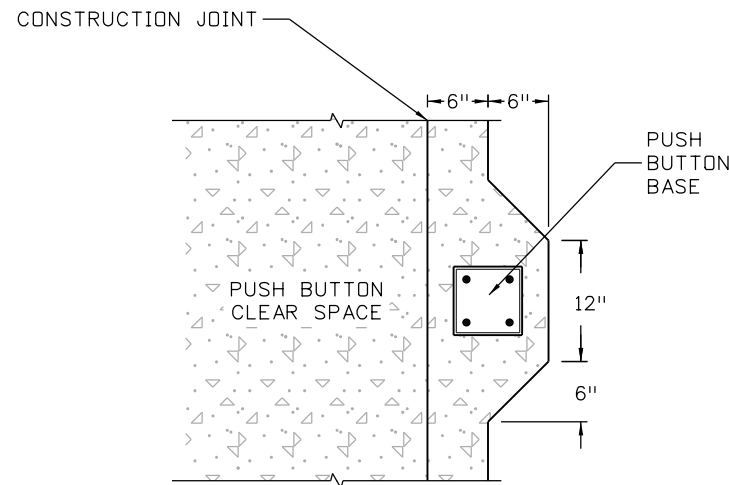

**Plan View**

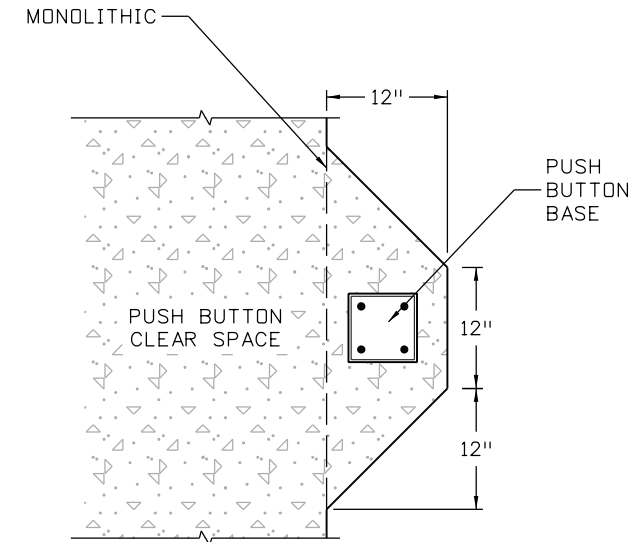

**Plan View**

**Notes**

1. 10 inches is the maximum side reach allowed. The pedestrian push button shall be located as close as possible to the push button clear space.
2. Bent anchor bolts shall maintain a minimum clear cover from the edge of concrete for the following installation conditions:
  - 2 inch clear cover for installations utilizing formwork
  - 3 inch clear cover for installations against earth
3. The access panel should be located on the opposite side of the push button base in relation to the pedestrian push button. If there is not 3 feet of access room behind the panel, locate the access panel below the pedestrian push button.

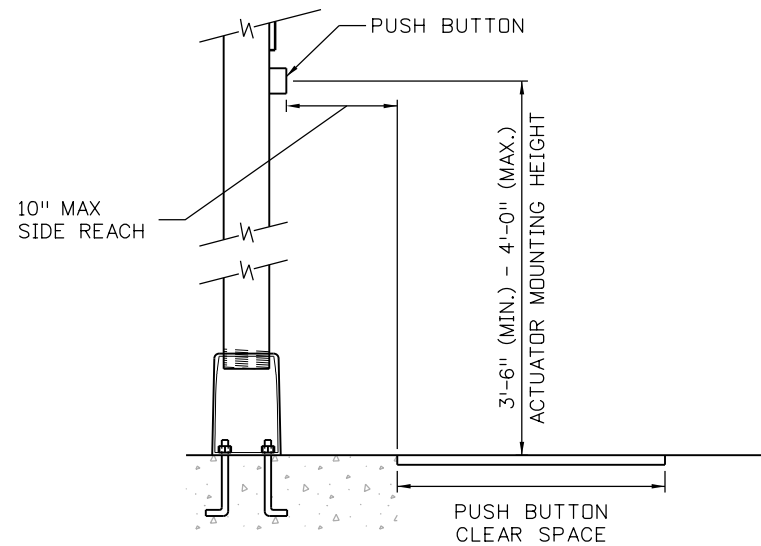

**Side View**

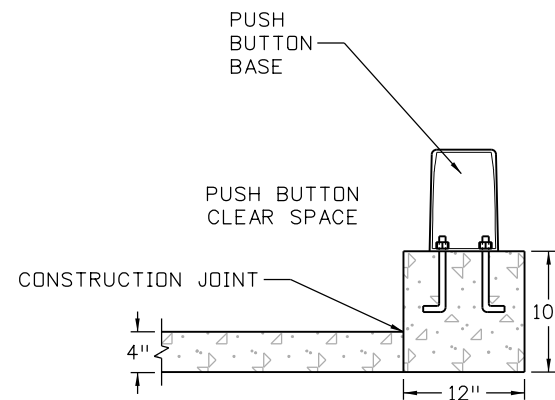

**Profile View**

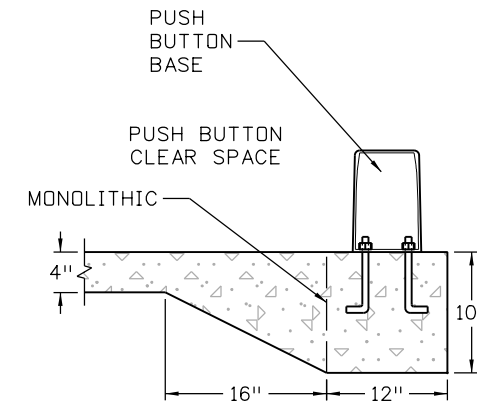

**Profile View**

**Push Button Location Detail**

**In-Curb Installation**

**Sidewalk Adjacent Installation**

<b>Computer File Information</b>		<b>Sheet Revisions</b>		<b>Colorado Department of Transportation</b>  <b>Traffic Safety &amp; Engineering Services</b> 2829 West Howard Place Denver, CO 80204 EB	<b>Pedestrian Push Button</b> <b>Post Assembly Details</b>	<b>Standard Plan No.</b>
Creation Date: 01/22/2020		Date:	Comments			<b>S-614-45</b>
Created By: TDN						Standard Sheet No. 3 of 6
Last Modification Date: 07/01/26					Project Sheet Number:	
Last Modified By: NRR						
CAD Ver.: ORD 10.12 Scale: Not to Scale Units: English						

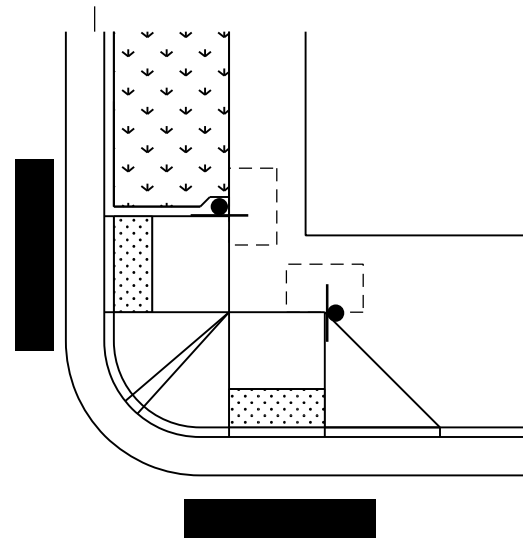

**Type 1 Ramps For Wide Sidewalk**

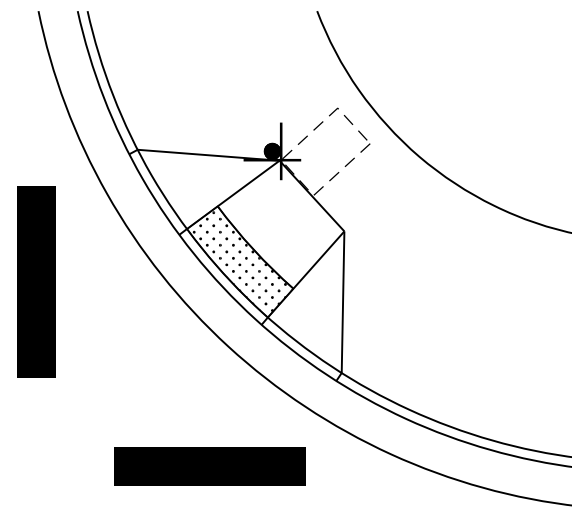

**Type 1 Ramp**

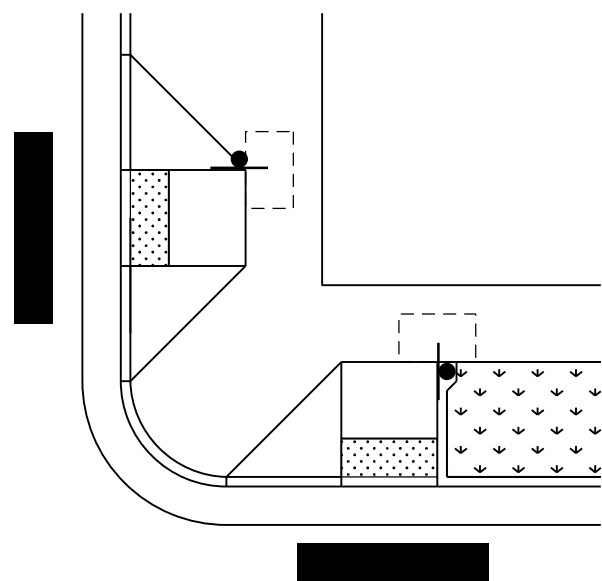

**Type 1 Ramps For Wide Sidewalk**

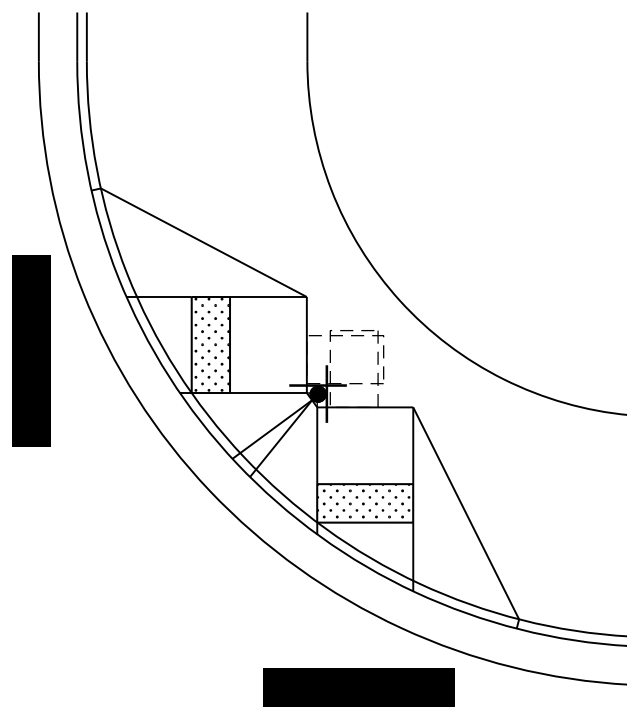

**Type 1 Directional Ramps**

**Notes**

1. Pedestrian push button post assemblies shown on Sheets 4 through 6 are recommended locations. If the recommended locations are not feasible, see Notes 6, 7 & 8 for alternate location placements.
2. See Standard M-608-1 for all slope, length, allowable use, and other requirements for curb ramps.
3. A clear space shall be provided adjacent to the pedestrian push button. The clear space shall measure 2.5 feet (minimum) in width and 4 feet (minimum) in the direction of pedestrian travel.
4. The clear space shall have a running slope consistent with the grade of the adjacent pedestrian access route and a cross slope of 2.0% maximum. Placement of the pedestrian push button post assembly at the corner of the clear space is acceptable as long as the side reach and mounting height are met. However, best practice should be to locate the pedestrian push button post assembly in the middle of the 4 foot clear space dimension to better facilitate side reach.
5. Mounting height of the pedestrian push button shall be between 42 and 48 inches.
6. The pedestrian push button shall be located as close as possible to the push button clear space. 10 inches is the maximum side reach allowed.
7. The pedestrian push button post assembly should be placed between 1.5 and 6 feet from the edge of curb, shoulder, or pavement. Where there are constraints that make it impractical to meet this distance, it should not be placed farther than 10 feet from the edge of curb, shoulder, or pavement. Pedestrian push button post assemblies shall not obstruct the required 4 foot pedestrian access path.
8. The pedestrian push button post assembly shall be placed within 5 feet of the edge of crosswalk/crossing.
9. Mount the pedestrian push button, the sign, and/or sign housing so that the face is parallel with the associated crosswalk/crossing.
10. Screw the shaft to a tightened position before mounting the pedestrian push button unit to the shaft.
11. Plumb the pedestrian push button post assembly with leveling shims.
12. Two push buttons on the same corner should be separated by 10 feet. Where there are physical constraints on a particular corner that make it impractical to provide this separation, the push buttons may be placed closer together or on the same pole.
13. When two push buttons are separated by less than 10 feet, accessible pedestrian signals shall be installed and the speech walk message shall be activated.

**Legend**

- Pedestrian Push Button Post Assembly
- Clear Space (2.5' X 4') (minimums)

<b>Computer File Information</b>		<b>Sheet Revisions</b>		 <b>Colorado Department of Transportation</b> <b>Traffic Safety &amp; Engineering Services</b> 2829 West Howard Place Denver, CO 80204 EB	<b>Pedestrian Push Button Post Assembly Details</b>	<b>Standard Plan No.</b>
Creation Date: 01/22/2020		Date:	Comments			<b>S-614-45</b>
Created By: TDN						Standard Sheet No. 4 of 6
Last Modification Date: 07/01/26						Project Sheet Number:
Last Modified By: NRR						
CAD Ver.: ORD 10.12 Scale: Not to Scale Units: English						

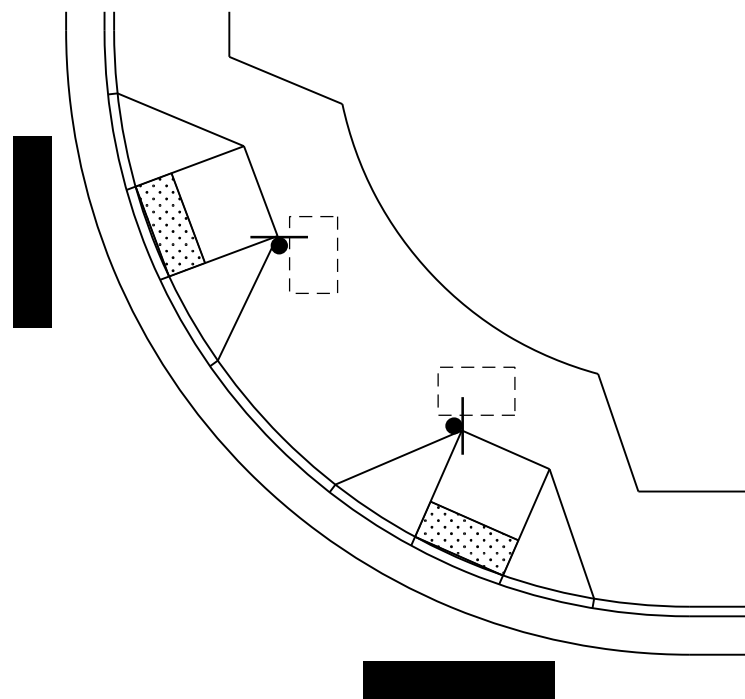

Type 1 Perpendicular Ramps

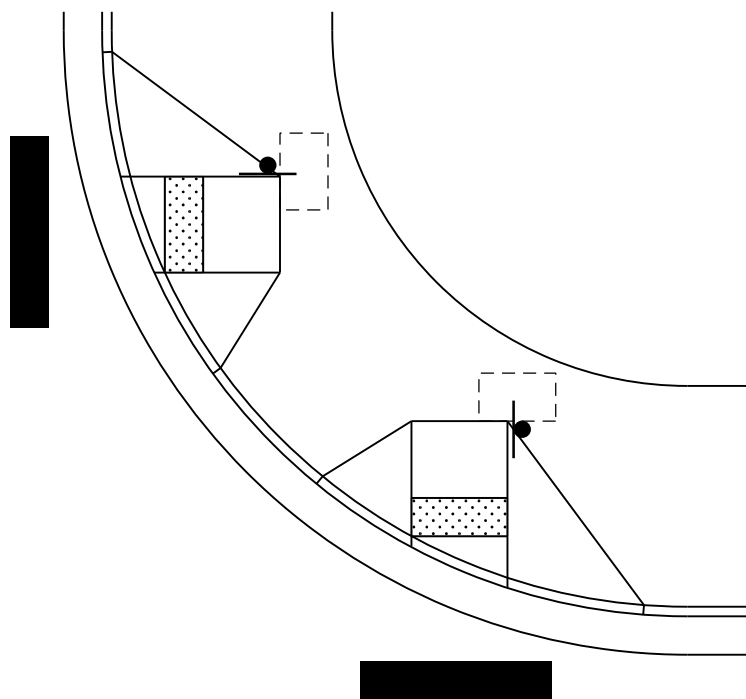

Type 1 Directional Ramps

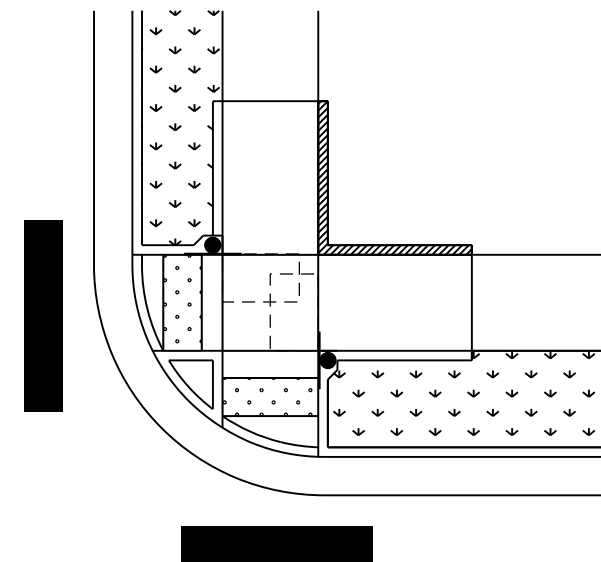

Type 1 Combination Ramp

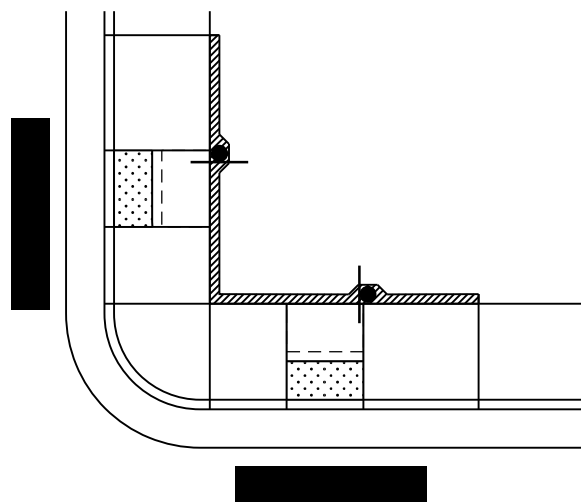

Type 2 Ramps Small Radius

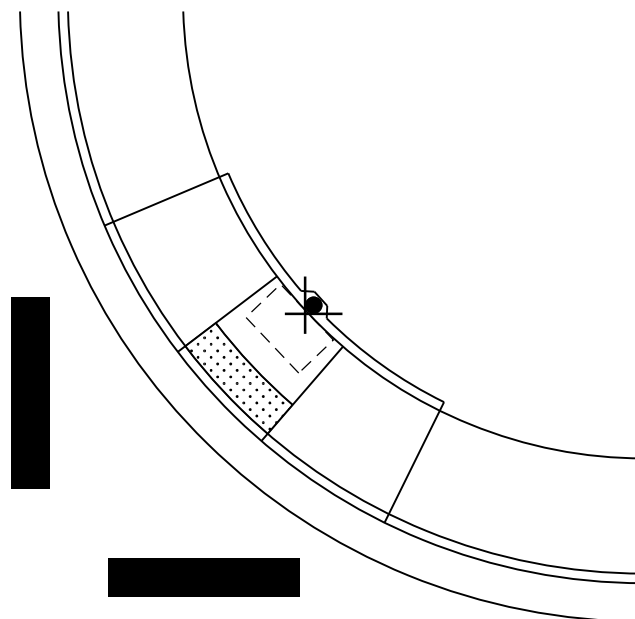

Type 2 Ramp (Diagonal)

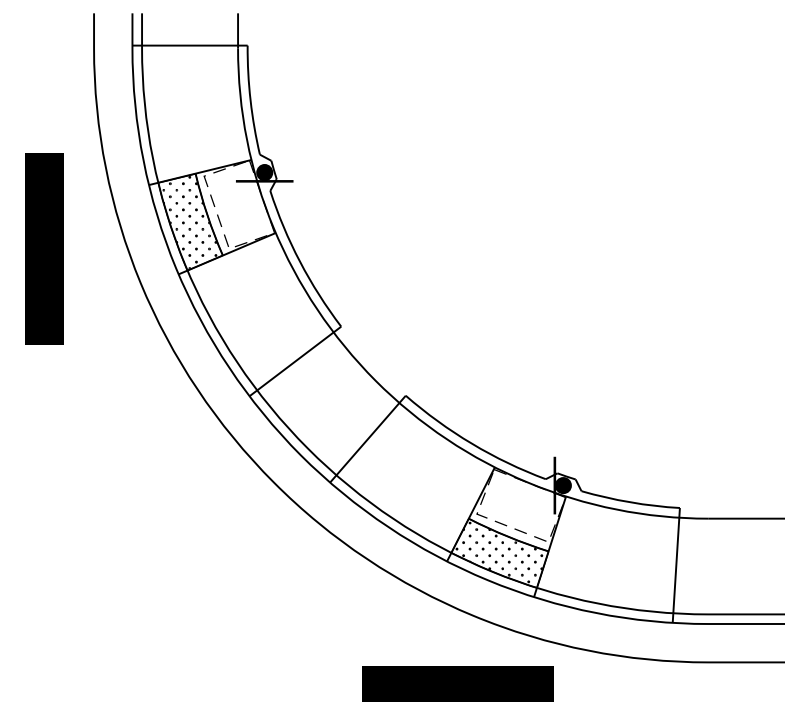

Type 2 Ramps Large Radius

Computer File Information	
Creation Date:	01/22/2020
Created By:	TDN
Last Modification Date:	07/01/26
Last Modified By:	NRR
CAD Ver.: ORD 10.12 Scale: Not to Scale Units: English	

Sheet Revisions	
Date:	Comments

Colorado Department of Transportation  
**Traffic Safety & Engineering Services**  
 2829 West Howard Place  
 Denver, CO 80204  
 EB

**Pedestrian Push Button  
 Post Assembly Details**  
 Issued by the Traffic Safety & Engineering Services: July 01, 2026

Standard Plan No. <b>S-614-45</b>
Standard Sheet No. 5 of 6
Project Sheet Number:

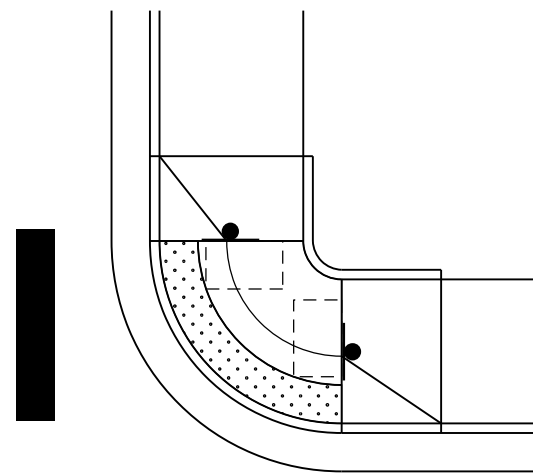

Blended Transition

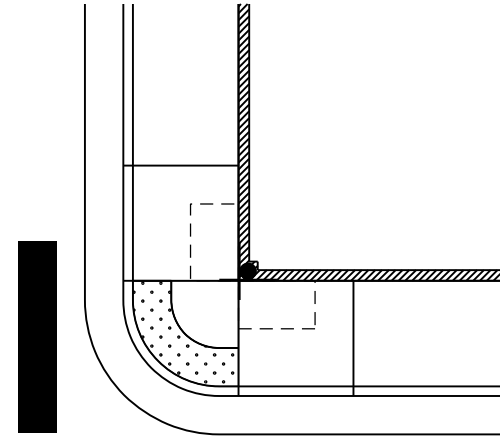

Depressed Corner

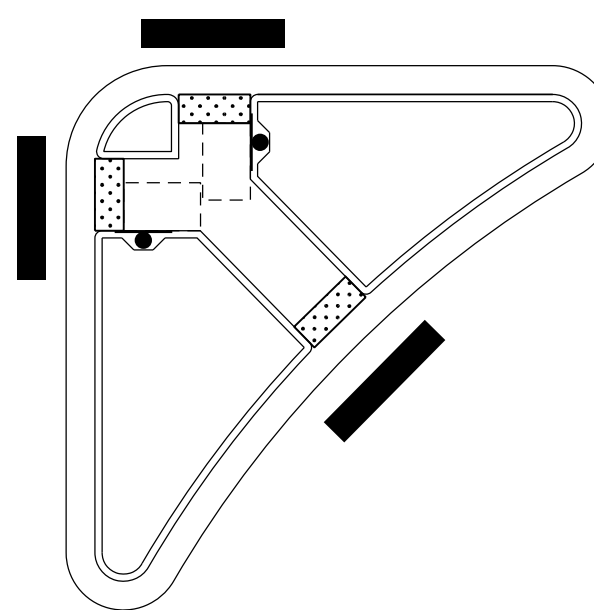
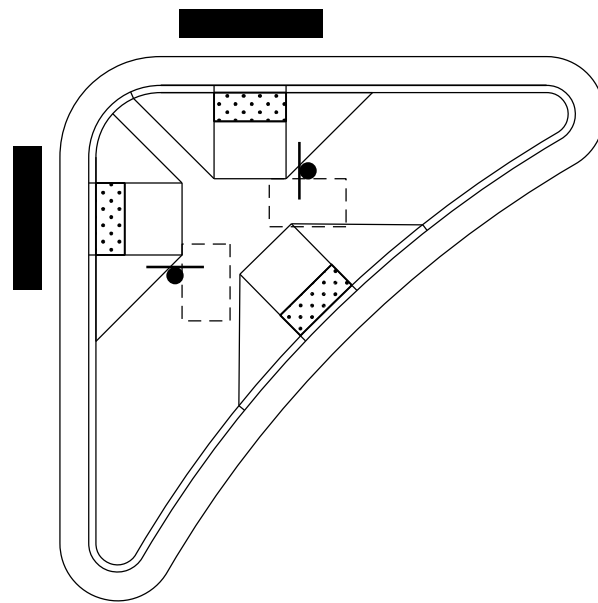

Intersection Islands

Computer File Information	
Creation Date:	01/22/2020
Created By:	TDN
Last Modification Date:	07/01/26
Last Modified By:	NRR
CAD Ver.: ORD 10.12 Scale: Not to Scale Units: English	

Sheet Revisions	
Date:	Comments

Colorado Department of Transportation

**Traffic Safety & Engineering Services**

2829 West Howard Place  
Denver, CO 80204

EB

**Pedestrian Push Button  
Post Assembly Details**

Issued by the Traffic Safety & Engineering Services: July 01, 2026

Standard Plan No.
<b>S-614-45</b>
Standard Sheet No. 6 of 6
Project Sheet Number: