

Typical Elevation Steel Post Assembly

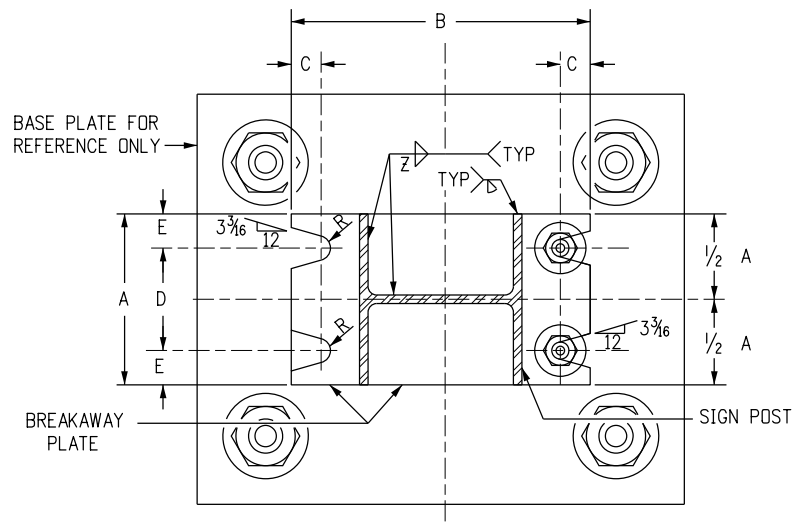

Section A-A

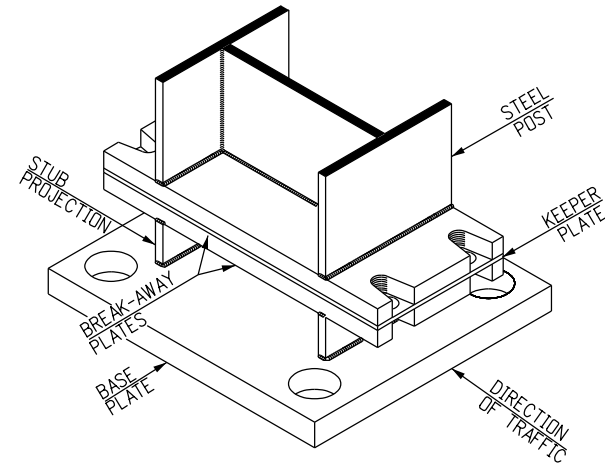

Typical Projected View Steel Post Assembly

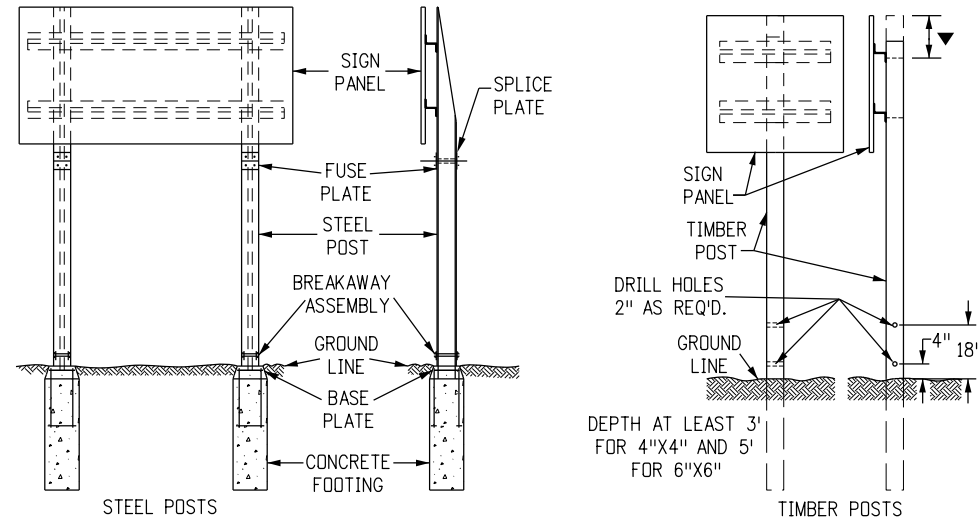

Typical Breakaway Sign Support Installations

**Bolting Procedure for Breakaway Plate Assembly**

1. Assemble the post to the stub with bolts, with one flat washer on the top of the upper breakaway plate and one below the lower breakaway plate, and one flat washer and a keeper plate between the breakaway plates.
2. Tighten all bolts to a "Snug Tight" condition with a 12 inch to 15 inch wrench, to bed the washers and clean the bolt threads. Then loosen each bolt in turn, and retighten in a systematic order to the prescribed torque (see Breakaway Plate Data tables).
3. Burr threads at junction with nut to prevent nut loosening.

**General Notes**

1. Design conforms with AASHTO "Specifications for the Design and Construction of Structural Supports for Highway Signs".
2. All structural steel shall conform to AASHTO M270 (ASTM A709) Grade 36 and Sections 509 and 614 of the Standard Specifications.
3. Steel fuse plates and splice plates shall conform to AASHTO M270 (ASTM A709) grade 36.
4. All structural steel including fuse and splice plates shall be galvanized in accordance with astm A123 after fabrication. Steel posts shall be stamped with their size.
5. All high strength bolts, nuts and washers shall conform to ASTM-A325. Washers used in the break-away plate and fuse plate assemblies shall be of sufficient strength to prevent any deflection or cupping into the slotted grooves under bolt torquing.
6. All bolts, nuts, and washers shall be galvanized as per ASTM-A153 or ASTM-A164.
7. All holes in fuse plate and post flange on which it mounts, shall be drilled. All others may be drilled or sub-punched and reamed.
8. All steel cuts shall preferably be saw cuts; however, flame cutting will be permitted provided all edges are ground. Remove all burrs. Metal shall not project beyond the plane of the plate face.
9. A "Keeper Plate" of 28-gage galvanized sheet metal, fabricated to match breakaway plate dimensions but with holes rather than slots, shall be used to prevent bolt loosening due to wind vibration.
10. High strength bolts in the breakaway assembly shall be tightened only to the torque shown in the table. Do not overtighten.
11. Timber posts shall be in accordance with Section 614 of the Standard Specifications as to size, alternate size, grade, species, treatment, and breakaway.
12. For all base plate and footing work see Standard Plan S-614-6.
13. For additional information, refer to "Tabulation of Sign and Cross Sections for Class III Signs" included in the plans.
14. Timber post shall be flush with top of sign panel for direct mount and 3 3/16 inch minimum above bolt for backing zee mount.
15. Timber sign post may only be used for temporary signage during construction. Tubular steel shall be used for permanent installations.
16. In no case shall a backing zee be placed below the fuse plates.
17. Sign post pay length is from the upper breakaway plate to the top of the "Cope". The 4-inch "Base Post" and the lower "Breakaway Plate" are paid for as part of the footing. The upper "Breakaway Plate" and all nuts, bolts, washers and keeper plate for fastening the breakaway plates are paid for as a part of the post.

**BREAKAWAY PLATE DATA TABLE**

DIMENSION	BOLT SIZE AND TORQUE	A	B	C	D	E	t1	WELD Z	R
		POST SIZE							
W 12 X 26	3/4" x 3 3/4" 46 Ft. Lb.	6 1/2"	17"	7/8"	3 1/2"	1 1/2"	1"	5/16"	1 3/32"
W 10 X 26		5 3/4"	14 7/8"	7/8"	3 1/4"	1 1/4"	1"	5/16"	1 3/32"
W 10 X 22		5 3/4"	14 5/8"	7/8"	3 1/4"	1 1/4"	1"	5/16"	1 3/32"
W 8 X 21	5/8" x 3" 29 Ft. Lb.	5 1/4"	12 5/8"	7/8"	2 3/4"	1 1/4"	1"	5/16"	1 3/32"
W 8 X 18		5 1/4"	12"	3/4"	3"	1 1/8"	3/4"	1/4"	1 1/32"
W 6 X 15		6"	10"	3/4"	3 3/4"	1 1/8"	3/4"	1/4"	1 1/32"
W 6 X 12		5"	10"	3/4"	2 3/4"	1 1/8"	3/4"	1/4"	1 1/32"

Computer File Information	
Creation Date: 07/04/12	
Created By: SCL	
Last Modification Date: 07/01/26	
Last Modified By: YSP	
CAD Ver.: ORD 10.12 Scale: Not to Scale Units: English	

Sheet Revisions	
Date:	Comments

**Colorado Department of Transportation**  
**Traffic Safety & Engineering Services**  
 2829 West Howard Place  
 Denver, CO 80204  
 EB

**Break-Away Sign Support**  
**Details For Class III Signs**  
 Issued by the Traffic Safety & Engineering Services: July 01, 2026

**Standard Plan No.**  
**S-614-5**  
**Standard Sheet No. 1 of 2**  
 Project Sheet Number:

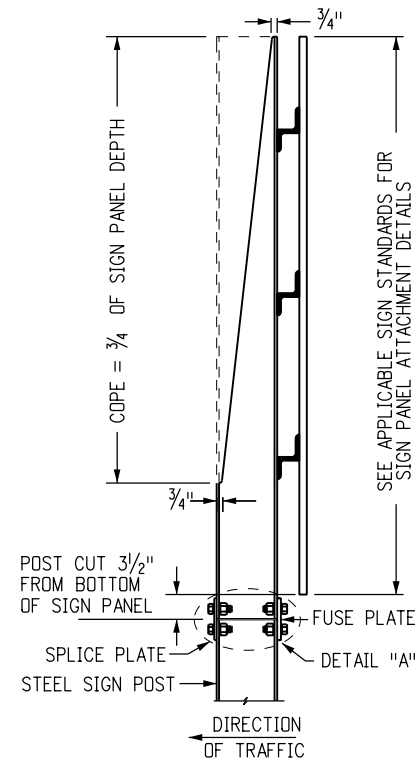

Typical Side View Fuse Plate and Post Cope

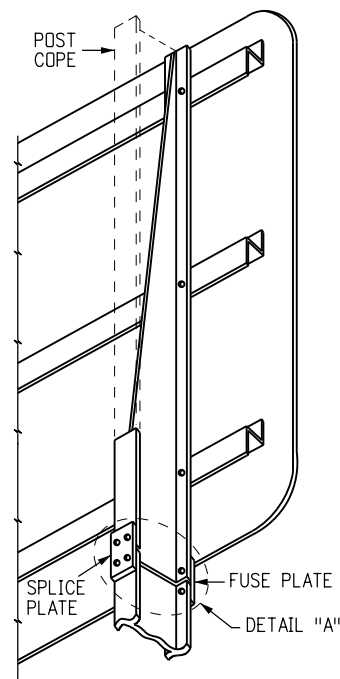

Typical Projected View Fuse Plate and Post Cope

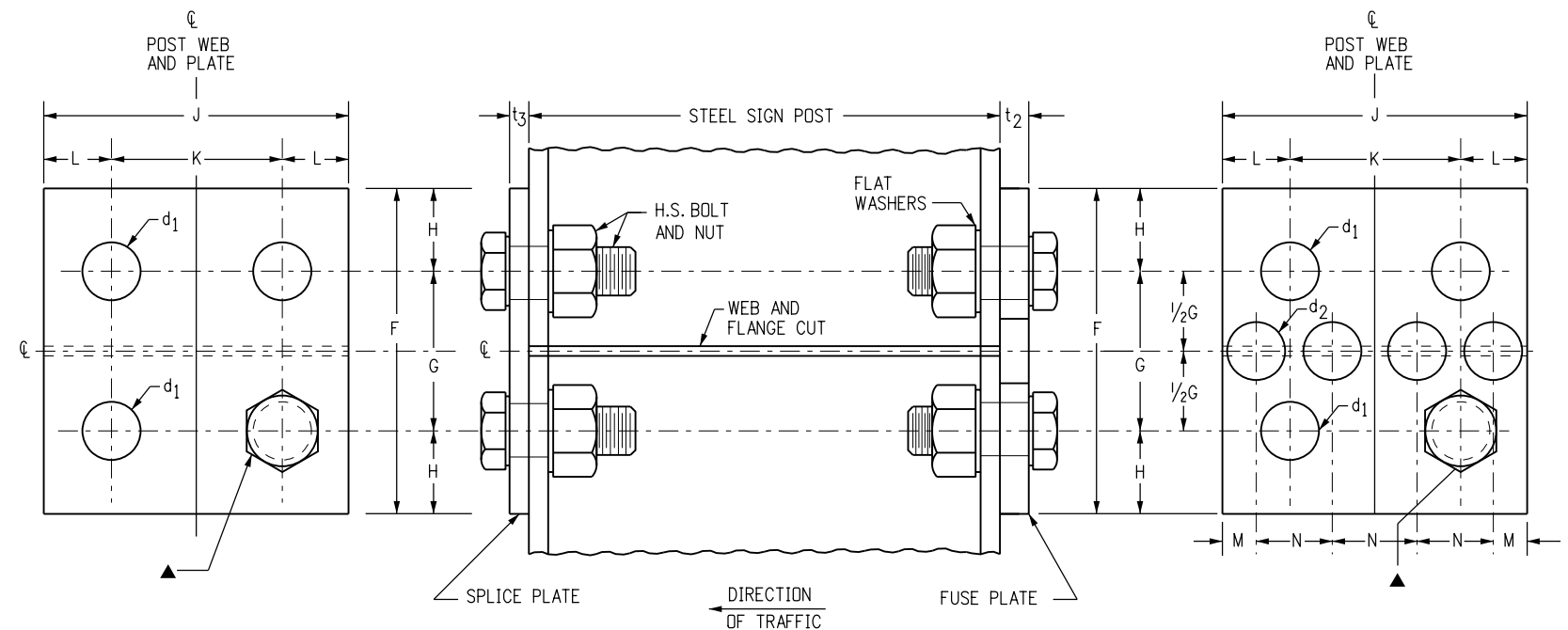

Splice Plate Detail

Detail "A" - Side View

Fuse Plate Detail

Typical Fuse and Splice Plate Hinge Details

▲ HOLE DIAMETER= d1  
USE HIGH STRENGTH BOLTS WITH HEX HEAD AND HEX NUT, WITH ONE FLAT WASHER UNDER EACH

FUSE AND SPLICE PLATE HINGE DATA TABLE														
SIZE POST	F	G	H	J	K	L	M	N	d <sub>1</sub>	d <sub>2</sub>	t <sub>2</sub>	t <sub>3</sub>	BOLT SIZE	FABRICATION NOTES
W 12 X 26	6"	3"	1 1/2"	6 1/2"	3 1/2"	1 1/2"	1 3/16"	1 5/8"	1 3/16"	1 3/16"	1/2"	7/16"	3/4" ø X 2 1/2"	ALL HOLES IN FUSE PLATE AND POST FLANGE HOLES ON WHICH IT MOUNTS SHALL BE DRILLED. ALL OTHERS MAY BE PUNCHED. BURR THREADS AT JUNCTION WITH NUT TO PREVENT NUT LOOSENING.
W 10 X 26	6"	3"	1 1/2"	5 3/4"	2 3/4"	1 1/2"	1 3/16"	1 3/8"	1 3/16"	1 1/8"	1/2"	7/16"	3/4" ø X 2 1/2"	
W 10 X 22	6"	3"	1 1/2"	5 3/4"	2 3/4"	1 1/2"	1 3/16"	1 3/8"	1 3/16"	1 1/8"	1/2"	3/8"	3/4" ø X 2 1/2"	
W 8 X 21	5 1/2"	2 1/2"	1 1/2"	5 1/4"	2 3/4"	1 1/4"	3/4"	1 1/4"	1 3/16"	1"	1/2"	3/8"	3/4" ø X 2 1/2"	ASTM-A441, ASTM-572 GRADE 50, OR ASTM-A588 MAY BE SUBSTITUTED FOR AASHTO M270 (ASTM A709) GRADE 36 AT THE OPTION OF THE FABRICATOR. STEEL USED SHALL HAVE AN ULTIMATE TENSILE STRENGTH NOT TO EXCEED 80 KSI.
W 8 X 18	5"	2 1/2"	1 1/4"	5 1/4"	2 3/4"	1 1/4"	3/4"	1 1/4"	1 1/16"	1 1/16"	3/8"	3/8"	5/8" ø X 2 1/2"	
W 6 X 15	5"	2 1/2"	1 1/4"	6"	3 1/2"	1 1/4"	3/4"	1 1/2"	1 1/16"	1 1/4"	3/8"	1/4"	5/8" ø X 2 1/2"	
W 6 X 12	4 1/4"	2"	1 1/8"	4"	2 1/4"	7/8"	1/2"	1"	9/16"	3/4"	1/4"	1/4"	1/2" ø X 2 3/4"	

Computer File Information	
Creation Date: 07/04/12	
Created By: SCL	
Last Modification Date: 07/01/26	
Last Modified By: YSP	
CAD Ver.: ORD 10.12 Scale: Not to Scale Units: English	

Sheet Revisions	
Date:	Comments

Colorado Department of Transportation

Traffic Safety & Engineering Services

2829 West Howard Place  
Denver, CO 80204

EB

**Break-Away Sign Support  
Details For Class III Signs**

Issued by the Traffic Safety & Engineering Services: July 01, 2026

Standard Plan No.  
**S-614-5**

Standard Sheet No. 2 of 2

Project Sheet Number: