

**Tubular Steel Posts  
(Socket System) (for use with all P-post Installations)  
(See Sheet 2 for P1 and P2 Post Installations)**

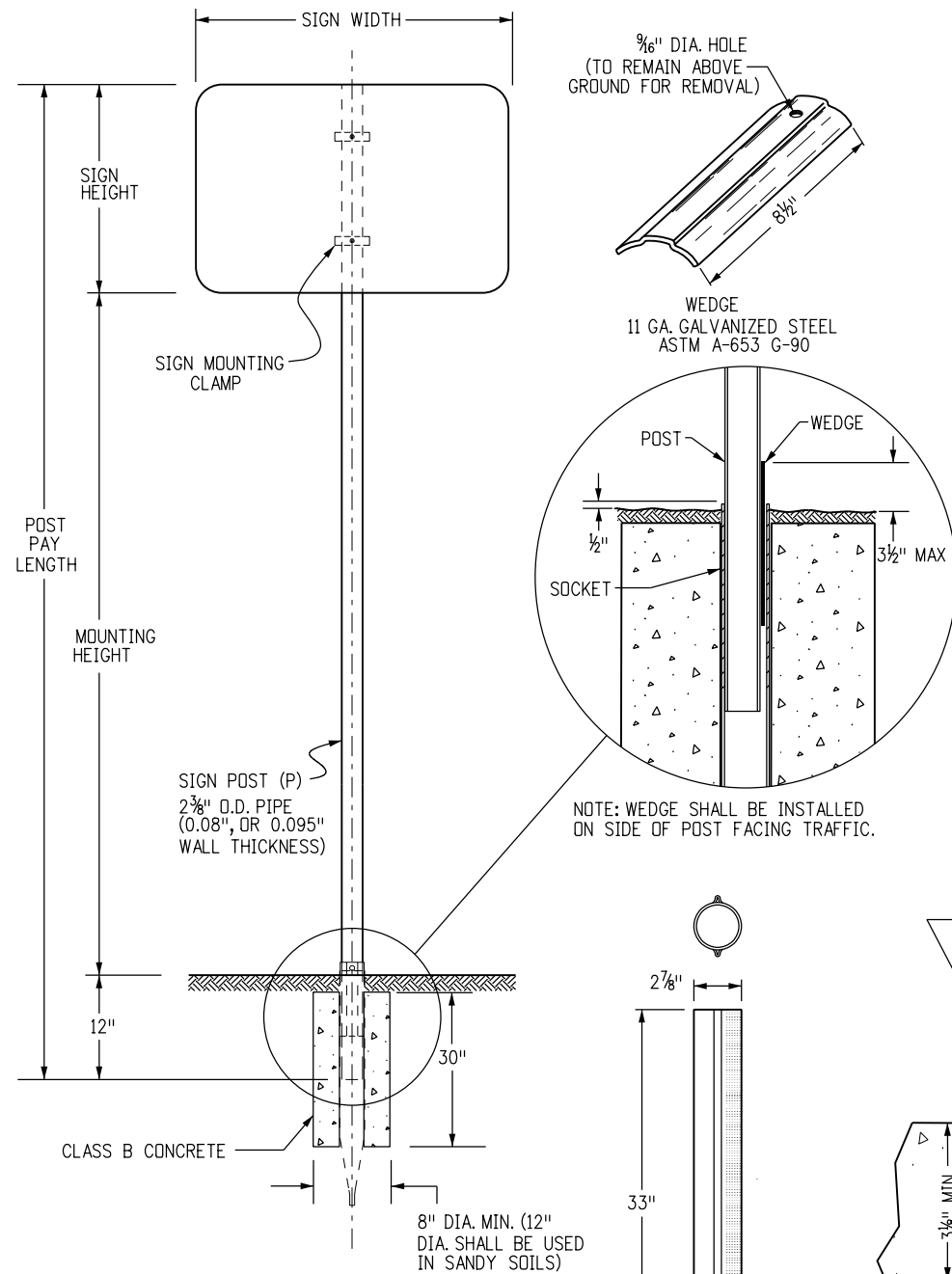

**Post Notes**

The post may be pre-punched with 3/8" diameter holes and the sign mounted directly to the post, or an approved mounting clamp may be used to mount the sign to the post. If the post is pre-punched, the holes shall be spaced the following distances from the top:  
1", 3", 10", 16", 21", 23", 24", 27", 33", 37", 39", AND 45"

TUBULAR CONCRETE FOOTING  
12 GA. GALVANIZED  
STEEL ASTM - 787

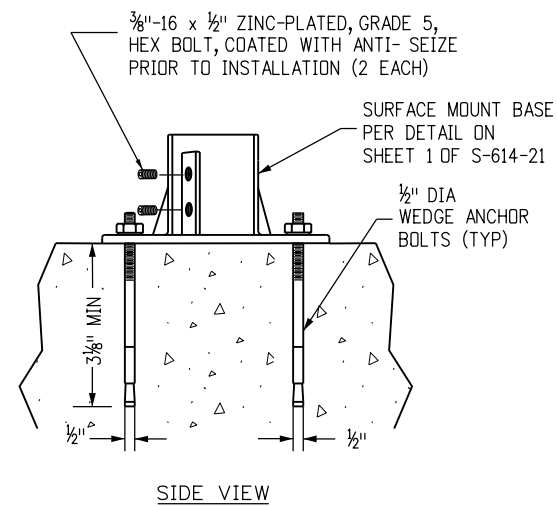

**Surface Mount Detail  
(P Post Only)**

**Signpost Selection Guide (90 MPH Wind Load Design)  
(for Socket System and Slipbase Installations Using P, P1 or P2 Posts)**

SIGN HEIGHT (FT)	7' MOUNTING HEIGHT															
	SIGN WIDTH (FT)															
	1	2	2.5	3	4	5	6	7	8	9	10	11	12+			
1	P	P	P	P	P	P1	SIZES NOT USED									
2	P	P	P	P	P	P1	SIZES NOT USED									
2.5	P	P	P	P	P1	P1	SIZES NOT USED									
3	P	P	P	P1	P1	P1	SIZES NOT USED									
4	P	P1	P1	P1	P1	P1	SIZES NOT USED							TWO P1'S		
5	SIZES NOT USED			P1	P1	P1	P1	SIZES NOT USED							TWO P2'S	
6	SIZES NOT USED			P1	P1	P1	P2	SIZES NOT USED							TWO P2'S	THREE P2'S
7	SIZES NOT USED			P1	P1	P2	SIZES NOT USED							TWO P2'S	SEE CHART NOTE 5.	

SEE CHART NOTE 4.

SIGN HEIGHT (FT)	8' MOUNTING HEIGHT										
	SIGN WIDTH (FT)										
	1	2	2.5	3	4	5	6	7	8	9	
1	P	P	P	P	P	P1	SIZES NOT USED				
2	P	P	P	P	P1	P1	SIZES NOT USED				
2.5	P	P	P	P1	P1	P1	SIZES NOT USED				
3	P	P	P1	P1	P1	P1	SIZES NOT USED				
4	P	P1	P1	P1	P1	P1	SIZES NOT USED				TWO P1'S
5	SIZES NOT USED			P1	P1	P1	P2	SIZES NOT USED			TWO P2'S
6	SIZES NOT USED			P1	P1	P1	P2	SIZES NOT USED			TWO P2'S
7	SIZES NOT USED			P1	P1	TWO P1'S	TWO P1'S	SIZES NOT USED			TWO P2'S

**Chart Notes**

- Typical post mounting heights from ground to bottom of sign panel are 7, 8 or 9 feet. Other heights may be required when signs are mounted on steeper fill or cut slopes.
- For signs mounted on two posts, the minimum distance between posts shall be 2 feet and the maximum distance shall be 8 feet. Distance from post to edge of sign panel(s) shall be 0 to 4 inches. When backing zeers are used, posts shall be installed with a minimum of 2 inches to the edge of the backing zee.
- All sign panels greater than 60 inches in width must be mounted on two posts to prevent turning.
- The post sizes shown are the minimum sizes required. Two P1 posts may be substituted where one P2 post is indicated. P2 posts may substituted for p1 posts when directed by the Engineer. W-shape beam may be substituted for P2 posts when directed by the Engineer.
- Use W-shape beams only for sign posts.

**Post Specifications**

POST SIZE	OUTSIDE DIAMETER	WALL THICKNESS	MATERIAL	** COATING	MAX ALLOW MOMENT	PAID FOR AS:
P	2.375"	.080"	ASTM-513	ASTM A-653 G-210 WITH 3.0 MIL	1.47 KIP FT	STEEL SIGN SUPPORT (2 INCH ROUND)
P1	2.875"	.160"	ASTM-513	POLYMER COATING PER ASTM A123 CLEAR COATING	4.02 KIP FT	STEEL SIGN SUPPORT (2 1/2 INCH ROUND NP-40)
P2	2.875"	.276"	ASTM-500	GC HOT DIPPED PER ASTM-123	5.13 KIP FT	STEEL SIGN SUPPORT (2 1/2 INCH ROUND SCH 80)

\*\* COLOR POWDER COATING MAY BE ADDED ACCORDING TO MANUFACTURER SPECIFICATIONS FOR SPECIAL LOCATIONS WHEN SHOWN ON THE PLANS.

**General Notes**

- Sign panels less than 60 inches in width may be attached directly to t brackets without zeers and sign panels less than 48 inches in width may be attached directly to U-brackets without zeers. Width of a diamond configured sign panel is measured across opposite corners.
- U-brackets may be used for multiple sign installations.
- For backing zee requirements and details, see Standard Plans S-614-3 and S-614-4.
- The contractor shall install the posts per the manufacturer's recommendations without additional compensation.

Computer File Information	
Creation Date: 07/04/12	
Created By: KEN	
Last Modification Date: 07/01/26	
Last Modified By: YSP	
CAD Ver.: ORD 10.12 Scale: Not to Scale Units: English	

Sheet Revisions	
Date:	Comments

**Colorado Department of Transportation**  
**Traffic Safety & Engineering Services**  
2829 West Howard Place  
Denver, CO 80204

**Tubular Steel Sign  
Support Details**

Issued by the Traffic Safety & Engineering Services: July 01, 2026

**Standard Plan No.**  
**S-614-8**  
**Standard Sheet No. 1 of 7**  
Project Sheet Number:

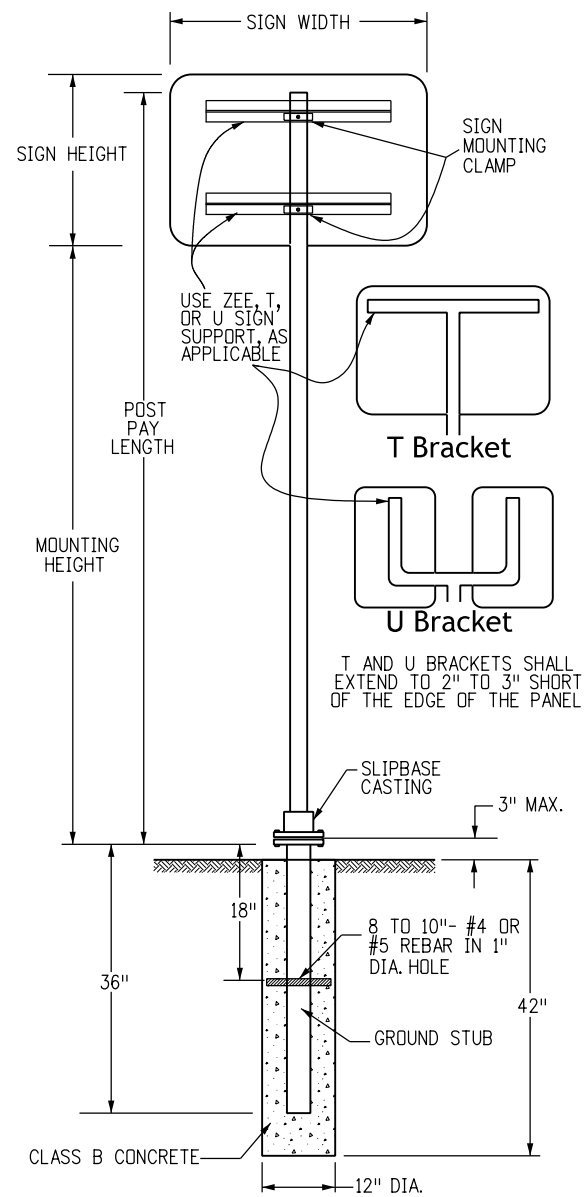

**Tubular Steel Post  
(with Slipbase)  
(for Use with All P1 and  
(See Sheet 1 for P-Post Installations)**

**Dimensions For Mounting Clamp (all Dimension Are In Inches)**

STANDARD PIPE SIZE	A	B	C	D	E	F	G	K	L	R <sub>1</sub>	R <sub>2</sub>
2	3 <sup>3</sup> / <sub>4</sub>	2 <sup>3</sup> / <sub>4</sub>	1 <sup>1</sup> / <sub>2</sub>	1 <sup>1</sup> / <sub>8</sub>	1/2	3/16	1	2 <sup>1</sup> / <sub>16</sub>	1 <sup>1</sup> / <sub>32</sub>	1 <sup>1</sup> / <sub>4</sub>	1 <sup>3</sup> / <sub>16</sub>
2 <sup>1</sup> / <sub>2</sub>	4 <sup>1</sup> / <sub>4</sub>	3 <sup>3</sup> / <sub>4</sub>	2	1 <sup>1</sup> / <sub>4</sub>	1/2	1/4	1	3 <sup>3</sup> / <sub>16</sub>	1 <sup>1</sup> / <sub>32</sub>	1 <sup>1</sup> / <sub>2</sub>	1 <sup>7</sup> / <sub>16</sub>

**T and U Bracket Attachment**

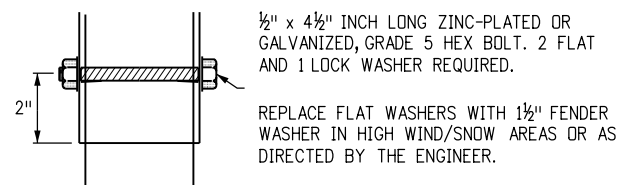

**Pipe Clamp Casting**

PIPE CLAMP CASTING SHALL BE ASTM B26 OR B108 ALUMINUM ALLOY A444.0-T4 OR 356.0-F. ALL SIGN MOUNTING CLAMP PARTS NOT MADE FROM ALUMINUM SHALL BE GALVANIZED STEEL IN CONFORMANCE WITH ASTM A153 OR STAINLESS STEEL.

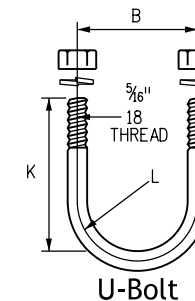

U-BOLT TO BE MADE IN ACCORDANCE WITH STANDARD MANUFACTURING PROCEDURE. 1/4" OR 5/16" DIAMETER STOCK IS PERMISSIBLE. AMERICAN STANDARD REGULAR SEMI-FINISHED HEX NUTS AND SPRING LOCKWASHERS.

**Typical Single Bracket**

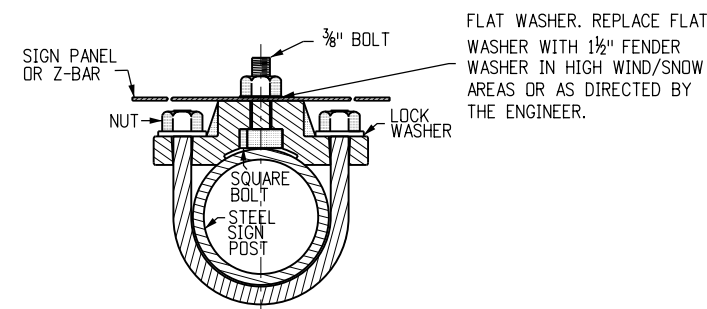

**Typical Back To Back**

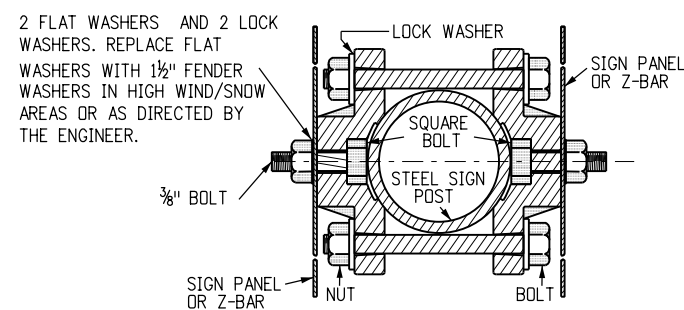

**Details for Sign Panel Attachment**

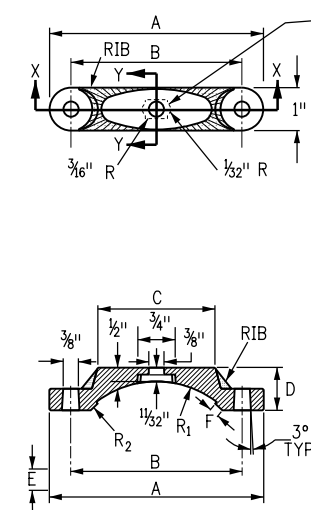

**Section X-X**

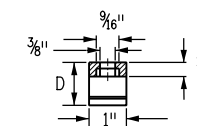

**Section Y-Y**

**Mounting Clamp for Socket Or Slipbase**

Computer File Information	
Creation Date: 07/04/12	
Created By: SCL	
Last Modification Date: 07/01/26	
Last Modified By: YSP	
CAD Ver.: ORD 10.12 Scale: Not to Scale Units: English	

Sheet Revisions	
Date:	Comments

**Colorado Department of Transportation**  
**Traffic Safety & Engineering Services**  
 2829 West Howard Place  
 Denver, CO 80204  
 EB

**Tubular Steel Sign  
Support Details**

Issued by the Traffic Safety & Engineering Services: July 01, 2026

Standard Plan No.
<b>S-614-8</b>
Standard Sheet No. 2 of 7
Project Sheet Number:

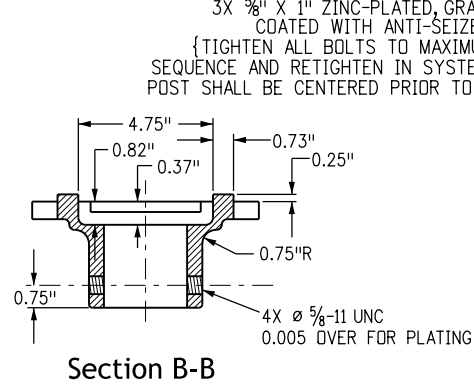
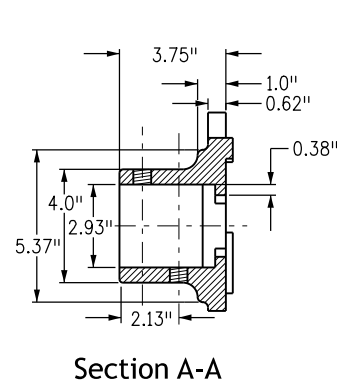
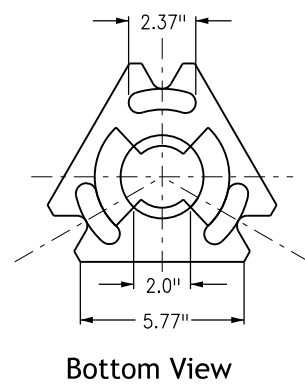
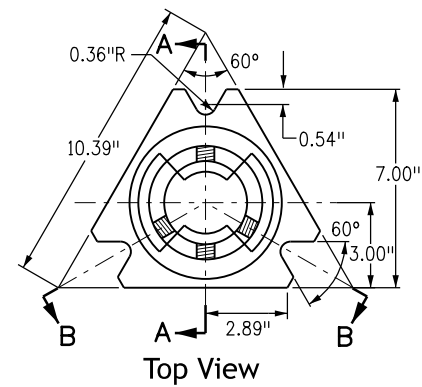

**Slipbase Casting 1**

DIRECTION OF TRAVEL

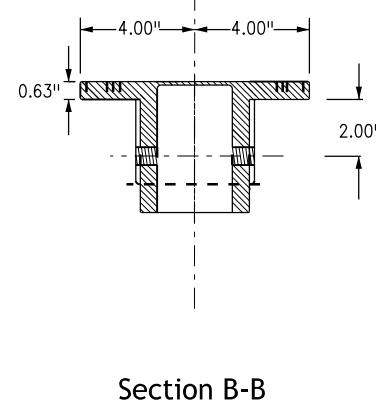
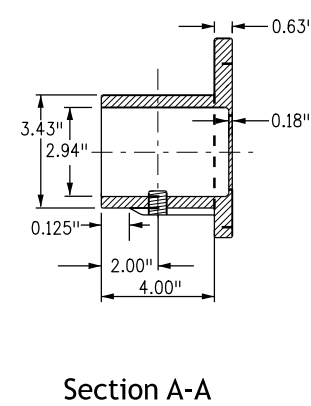
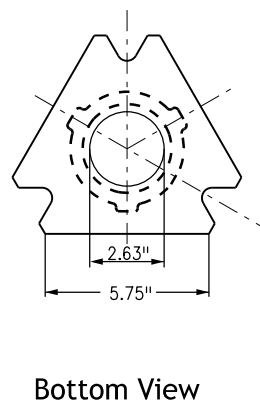
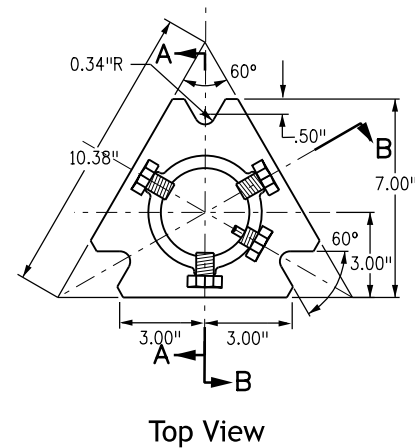

**Slipbase Casting 2**

DIRECTION OF TRAVEL

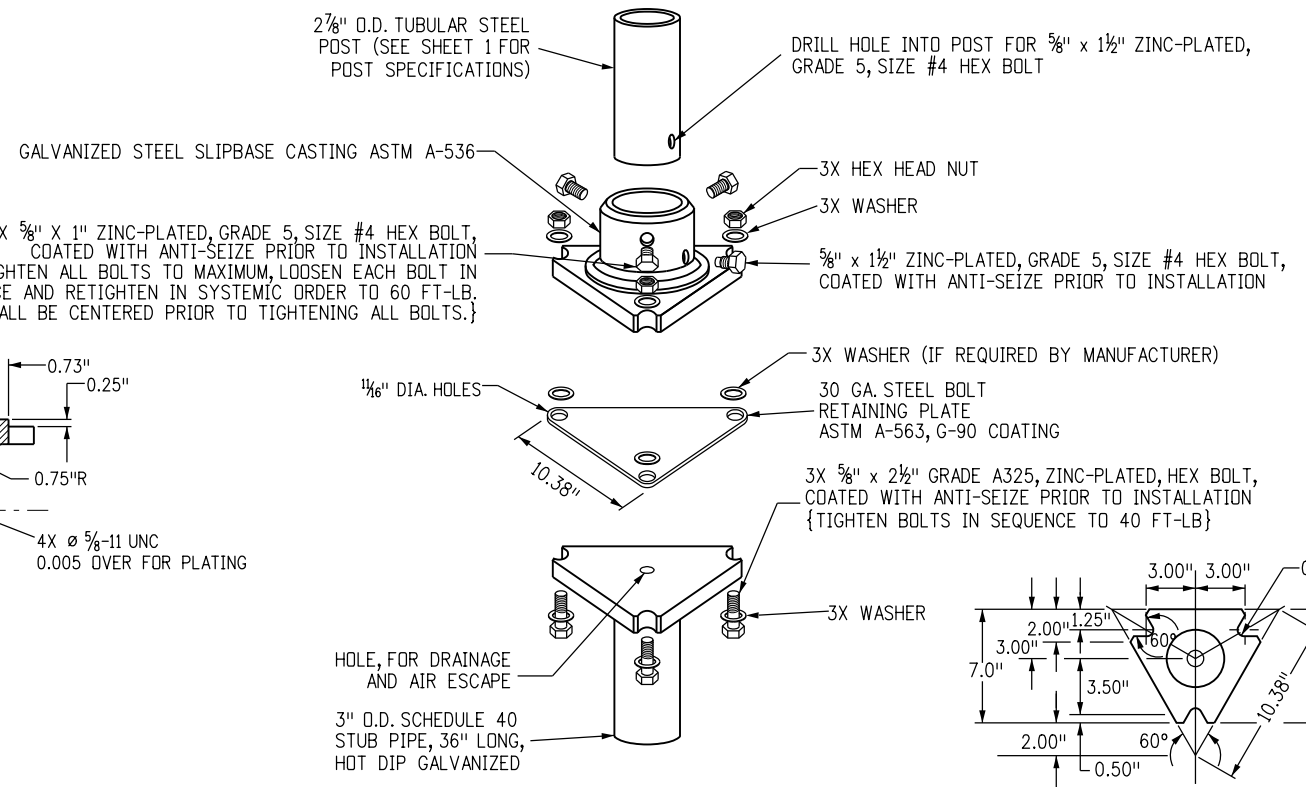

**Typical Assembly**

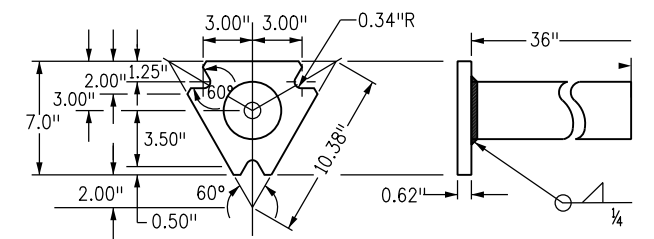

**Slipbase Stub Base**

**Slipbase Casting Requirements**

For 2-7/8 inch posts (P1 or P2 posts)  
galvanized steel slipbase casting ASTM-536

**Mounting Hardware**

- 3 - Each 5/8 x 2 1/2 inch long hex bolt
- 3 - Each 5/8 x 1 inch long zinc-plated, grade 5 size #4 hex bolt
- 1 - Each 5/8 x 1 1/2 inch long zinc-plated, grade 5 size #4 hex bolt
- 1 - Each 30 gauge steel bolt retaining plate ASTM A-563, G-90 coating

**Installation Requirements**

All hex bolts shall be coated with anti-seize prior to installation.

All hardware will be galvanized or zinc plated.

**Tubular Steel Sign Support Slipbase Notes**

1. Refer to signing plans for sign locations and height.
2. Minimum allowable tension capacity for wedge anchors = 3,000 pounds.
3. Maximum allowable moment for sign base = 5.13 kip-feet.
4. Pay item "Steel Sign Support(X-Inch Round)(Slipbase)" shall include stub base, casting and necessary hardware (slipbase casting mounting hardware as shown on this sheet).
5. Pay item "Steel Sign Support Casting" shall include casting and necessary mounting hardware (slipbase casting mounting hardware as shown on this sheet).
6. Pay item "Steel Sign Ground Stub Base (36 Inch)" shall include slipbase stub base.

**Cast-in-place Slipbase For New Installations**

<b>Computer File Information</b>		<b>Sheet Revisions</b>		<p><b>Colorado Department of Transportation</b> Traffic Safety &amp; Engineering Services 2829 West Howard Place Denver, CO 80204 EB</p>	<p><b>Tubular Steel Sign Support Details</b></p>	<b>Standard Plan No.</b>	
Creation Date: 07/04/12		Date:	Comments			<b>S-614-8</b>	
Created By: KEN						Standard Sheet No. 3 of 7	
Last Modification Date: 07/01/26						Project Sheet Number:	
Last Modified By: YSP							
CAD Ver.: ORD 10.12 Scale: Not to Scale Units: English							

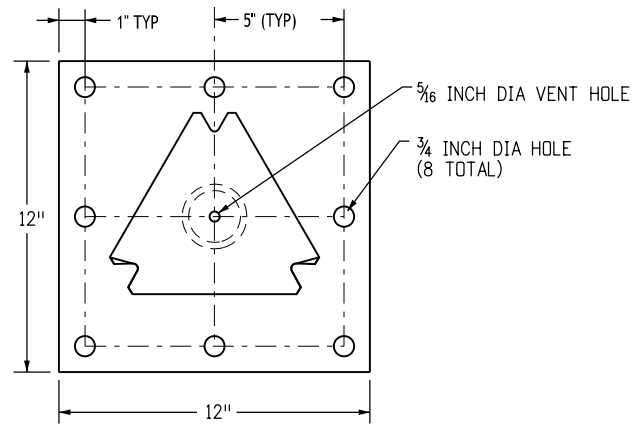

**Surface Mount Slipbase Base Plate Fabrication Requirements**

Base Plate - 3/4 inch ASTM A 36 plate steel  
 Pipe Stub - 3 inch Nominal Schedule 80, ASTM A-500 Grade B  
 Top Plate - meet requirements of sheet 3

Meet ASTM A-123 galvanizing after fabrication is complete

**Surface Mount Slipbase Tubular Steel Sign Base Requirements**

For 2-7/8 inch posts (P1 or P2 Posts)  
 For concrete surfaces greater than 7 inches thick  
 For concrete surfaces greater than 12 inches in width

**Mounting Hardware**

- 8 - each 5/8 x 5<sup>59</sup>/<sub>64</sub> inch long "Hilti Kwik HUS-EZ Screw Anchors
- 16 - each 5/8 inch flat washers
- 8 - each 5/8 inch lock washers
- 8 - each 5/8 inch nuts

**Installation Requirements:**

Drill: (8) - 5/8 inch holes 6 inch deep, clean hole prior to installing anchors  
  
 Use additional washers for shimming to level base plate.

All hardware will be galvanized or zinc plated.

**Tubular Steel Sign Support Surface Mount Slipbase Notes**

1. Refer to signing plans for sign locations and height
2. Refer to Sheet 3 for slipbase casting information
3. Minimum allowable tension capacity for wedge anchors = 3000 pounds
4. Maximum allowable moment for sign base = 5.13 kip-feet
5. Pay item "Steel Sign Surface Mount Base Plate (Slipbase)" shall include base plate, casting and all necessary hardware (slipbase casting mounting hardware as shown on Sheet 3 and surface mount slipbase mounting hardware as shown on this Sheet)
6. Pay item "Steel Sign Surface Mount Base Plate" shall include base plate and necessary hardware (surface mount slipbase mounting hardware as shown on this Sheet)

SLIPBASE WILL MEET REQUIREMENTS OF STD PLAN NO. S-614-8 SLIPBASE STUB POST DETAIL EXCEPT FOR OVERALL HEIGHT

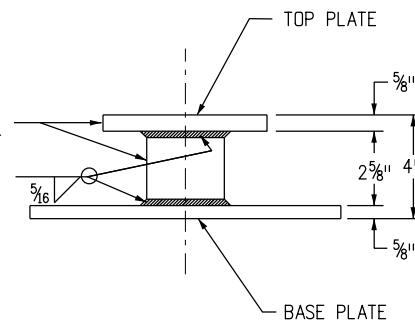

**Surface Mount Slipbase Base Plate**

Surface Mount Slipbase for Retrofit Installations

<b>Computer File Information</b>		<b>Sheet Revisions</b>		<b>Colorado Department of Transportation</b>  <b>Traffic Safety &amp; Engineering Services</b> 2829 West Howard Place Denver, CO 80204 EB	<b>Tubular Steel Sign Support Details</b> Issued by the Traffic Safety & Engineering Services: July 01, 2026	<b>Standard Plan No.</b>	
Creation Date: 07/04/12		Date:	Comments			<b>S-614-8</b>	
Created By: DiNardo	<input type="checkbox"/>					Standard Sheet No. 4 of 7	
Last Modification Date: 07/01/26	<input type="checkbox"/>					Project Sheet Number:	
Last Modified By: YSP	<input type="checkbox"/>						
CAD Ver.: ORD 10.12 Scale: Not to Scale Units: English	<input type="checkbox"/>						

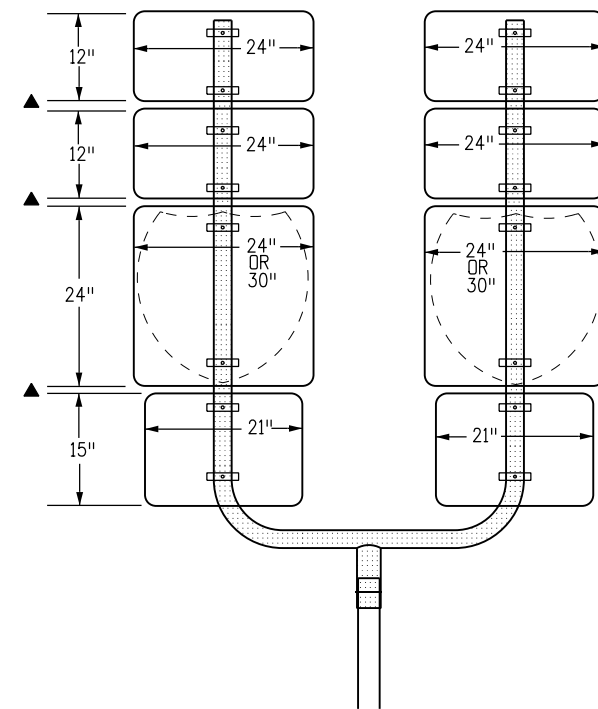
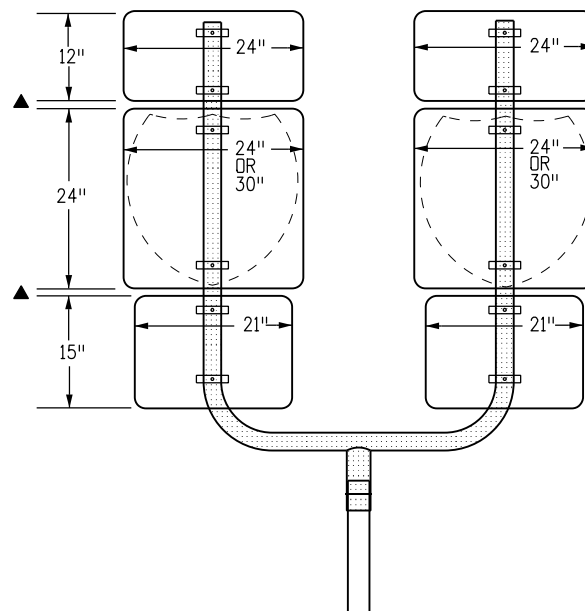
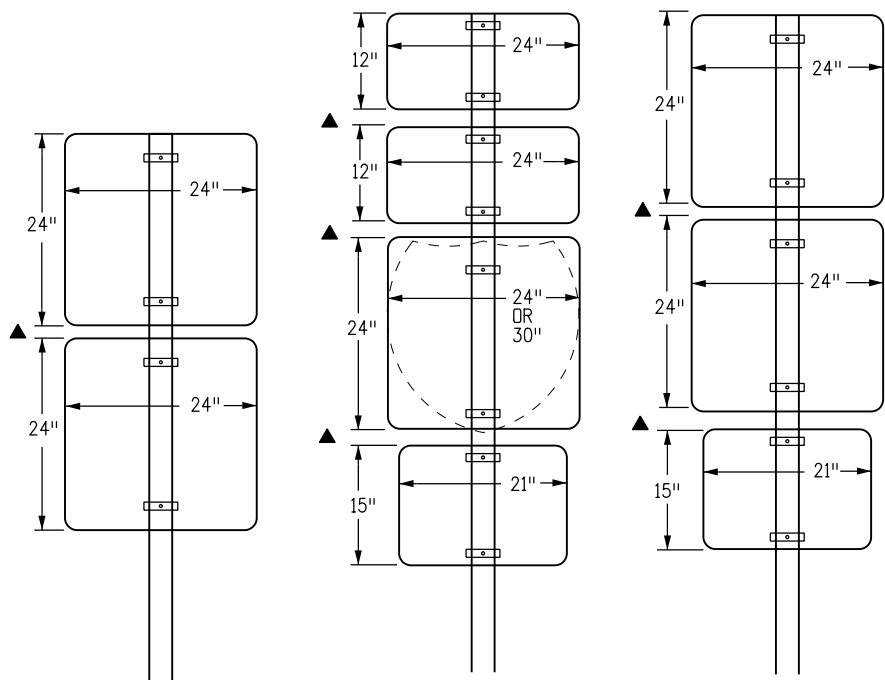
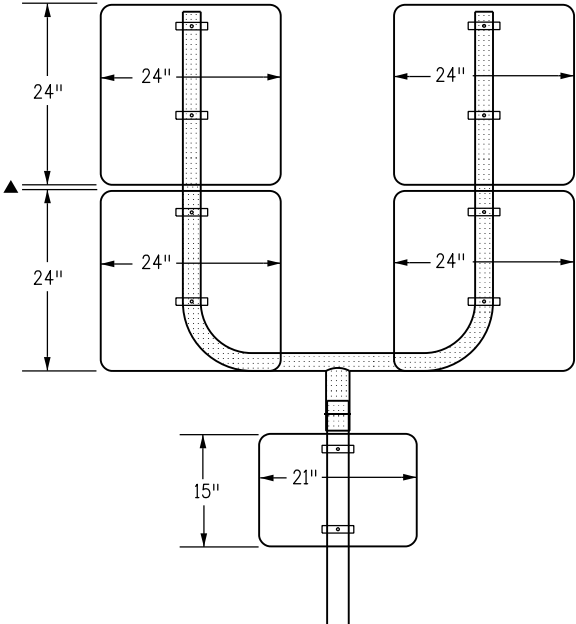
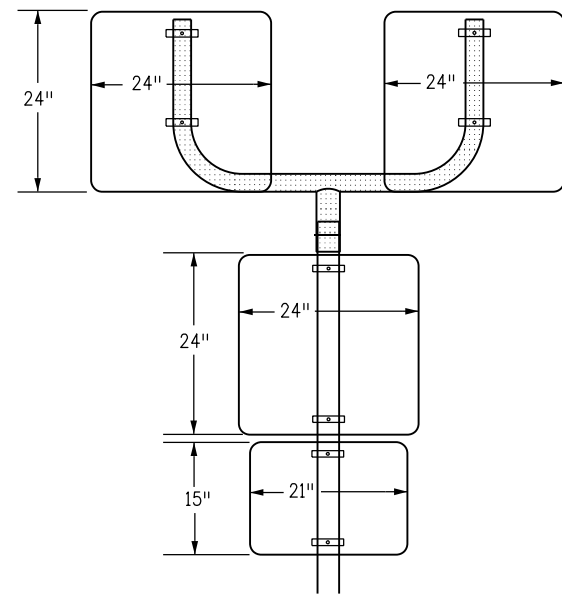
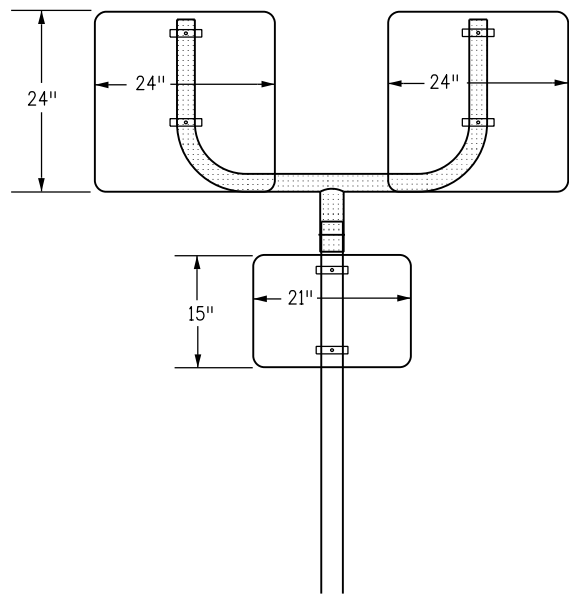
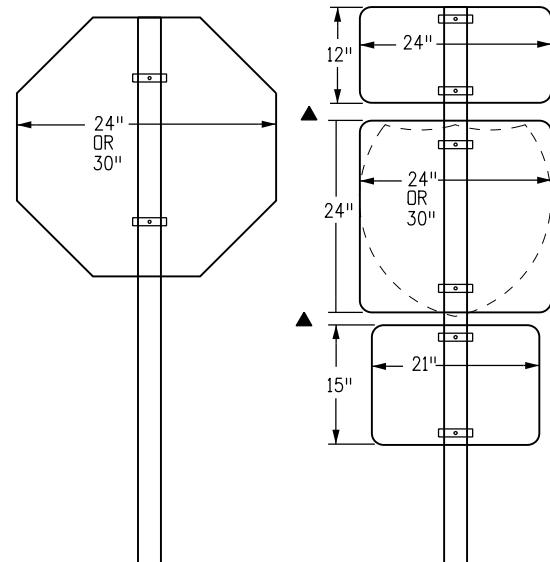

**Class I Sign Combinations (Direct Attachment)**

**Class I Sign Combinations Using U-Brackets**

▲ SEE NOTE 6 ON SHEET 6

<b>Computer File Information</b>		<b>Sheet Revisions</b>		 <b>Colorado Department of Transportation</b> <b>Traffic Safety &amp; Engineering Services</b> 2829 West Howard Place Denver, CO 80204 EB	<b>Tubular Steel Sign Support Details</b> Issued by the Traffic Safety & Engineering Services: July 01, 2026	<b>Standard Plan No.</b>	
Creation Date: 07/04/12	Created By: KEN	Date:	Comments			<b>S-614-8</b>	
Last Modification Date: 07/01/26	Last Modified By: YSP					Standard Sheet No. 5 of 7	
CAD Ver.: ORD 10.12 Scale: Not to Scale Units: English						Project Sheet Number:	

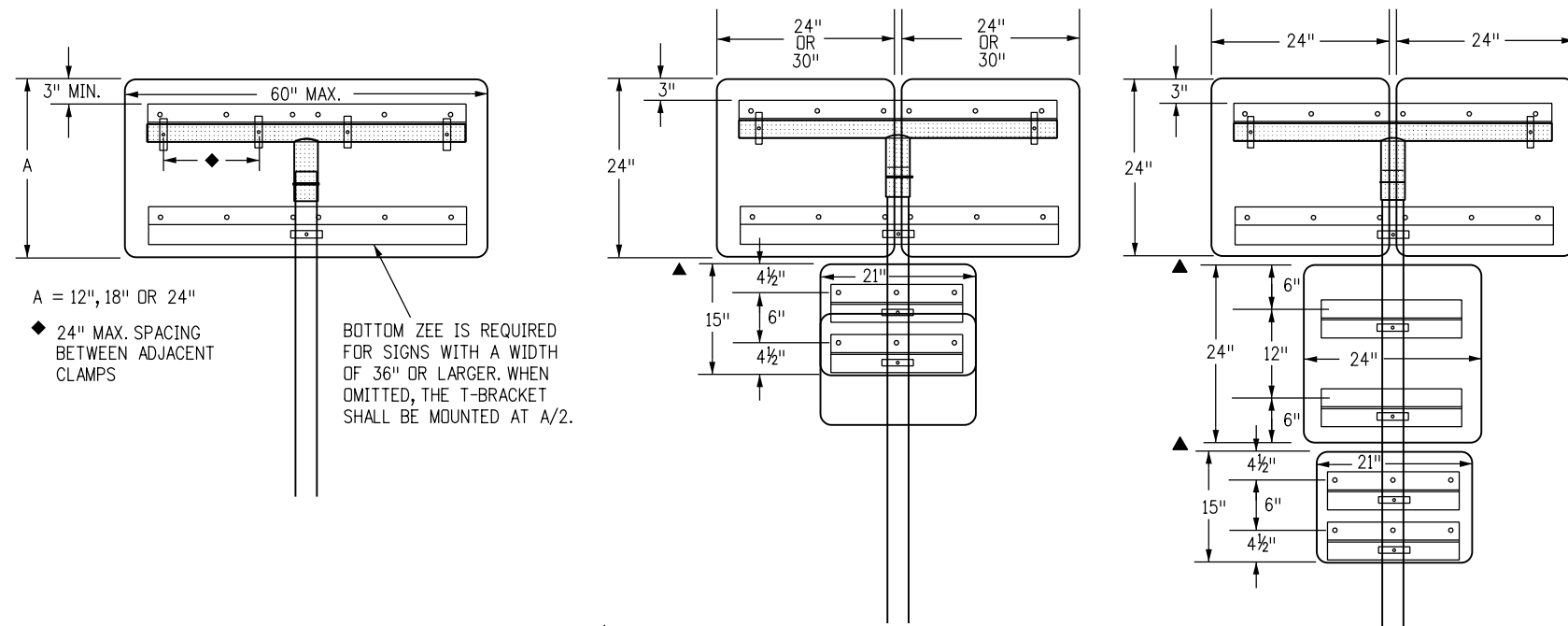

PANEL WIDTH	ZEE LENGTH
21"	15"
24"	18"
30"	24"
36"	30"
42"	36"
45"	39"
48"	42"
54"	48"
60"	54"
36" DIAMOND	22"
48" DIAMOND	36"
24" & 24"	43"
24" & 30"	49"
30" & 30"	55"
36" & 36"	67"
45" & 36"	76"
24" & 24" & 24"	68"
24" & 24" & 30"	74"
24" & 30" & 24"	74"
30" & 24" & 30"	80"
24" & 30" & 30"	80"
30" & 30" & 30"	86"

**NOTES**

1. Z-Bar length shall be 3 inch ( $\pm \frac{1}{2}$  inch) short of the edge of the sign or row of signs on both sides. The accompanying table gives the z-bar length for most typical panel combinations.
2. First and last holes shall be 2 inch from edge of z-bar. The holes in between shall be 6 inch to 8 inch apart.
3. T and U brackets shall terminate 2 inches to 3 inches from edge of sign panel. When a zee is connected to a T-bracket, they shall be the same length except when the zee must extend beyond the maximum length of a T-bracket.
4. Two mounting clamps are required on zees where there is only one zee for the panel and the zee is attached to only one post.
5. Zees shall be attached to T-brackets and U-brackets with U-bolts or mounting clamps.
- ▲ 6. Vertical spacing between sign panels shall be 1 inch to 1½ inch typical.
7. In special cases U-brackets may be used to mount signs that face different directions. The Engineer shall determine the orientation of the sign panels and verify that the maximum allowable wind loads for the post are not exceeded.

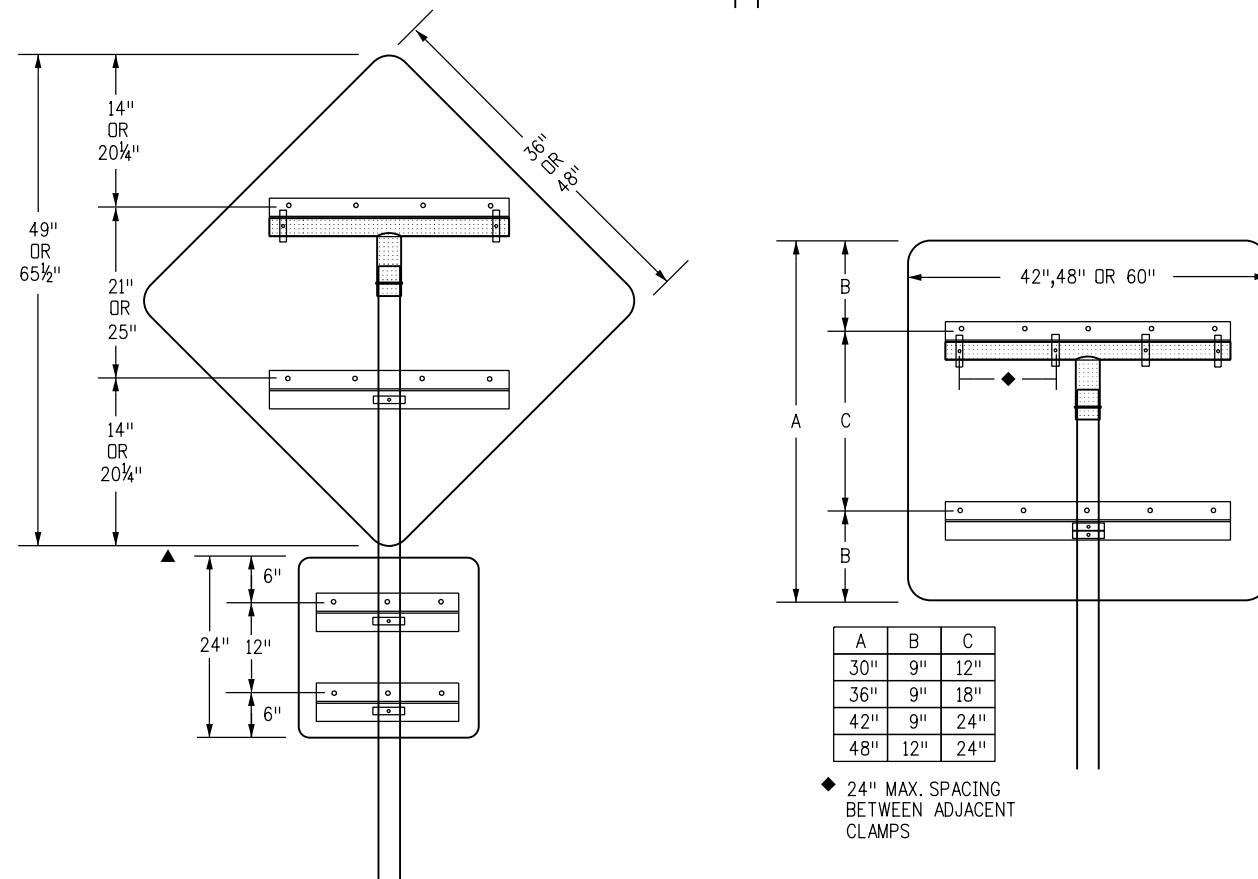

**Class II Sign Combinations Using T-Brackets With Z-Bar**

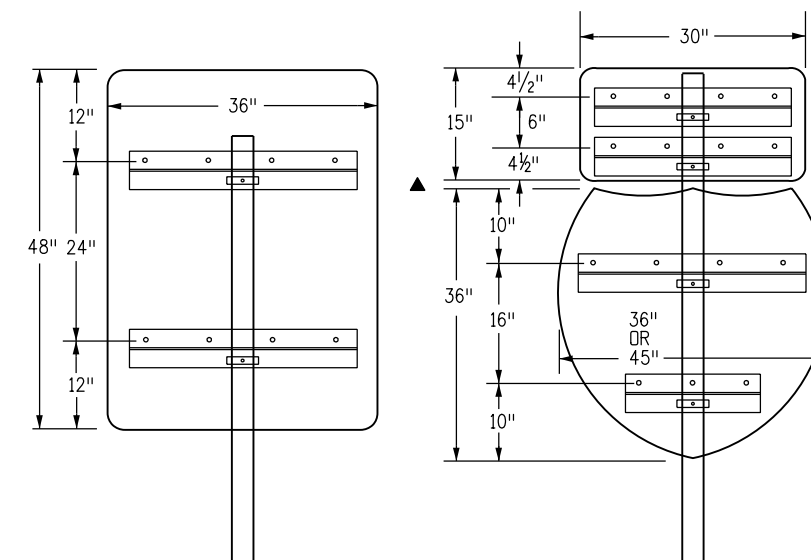

**Single Post Class II Signs Using Z-Bar**

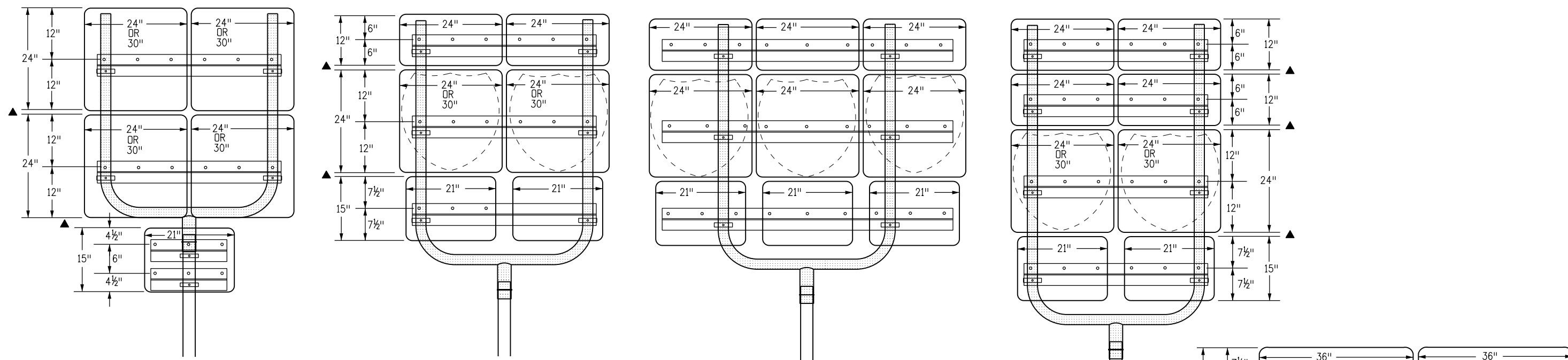

**Class II Sign Combinations Using U-Brackets**

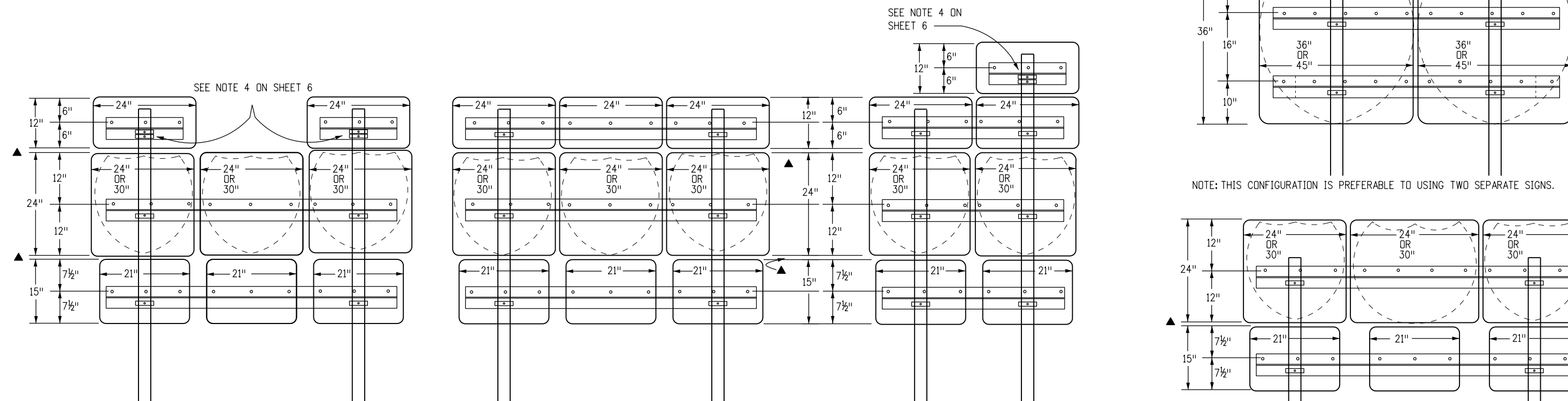

NOTE: THIS CONFIGURATION IS PREFERABLE TO USING TWO SEPARATE SIGNS.

▲ SEE NOTE 6 ON SHEET 6

**Class II Sign Combinations Using Two Posts**

Computer File Information	
Creation Date:	07/04/12
Created By:	KEN
Last Modification Date:	07/01/26
Last Modified By:	YSP
CAD Ver.:	ORD 10.12 Scale: Not to Scale Units: English

Sheet Revisions	
Date:	Comments

**Colorado Department of Transportation**  
**Traffic Safety & Engineering Services**  
 2829 West Howard Place  
 Denver, CO 80204  
 EB

**Tubular Steel Sign Support Details**  
 Issued by the Traffic Safety & Engineering Services: July 01, 2026

**Standard Plan No.**  
**S-614-8**  
**Standard Sheet No. 7 of 7**  
 Project Sheet Number: