

## General Notes

1. Minimum longitudinal pavement marking width:

Facility Type	Speed	Edge Lines	Lane Lines	Center Lines <sup>1</sup>	Dotted Lane Lines	Lane Drop/Aux Lines
2-Lane Facilities	All	6"	n/a	4"	n/a	n/a
3-Lane Facilities	All	6"	6"	4"	6"	8"
Multi-Lane Facilities $\geq 50$ MPH		6"	6"	4"	6"	8"
Multi-Lane Facilities $\leq 45$ MPH		4"	4"	4"	4"	8"

<sup>1</sup>Applies to facility types with double yellow lines, painted median, or undivided highway.

- Temporary Pavement Marking  
4 inch wide marking can be used instead of 6 inch wide marking for temporary marking unless otherwise directed by the Region Traffic Engineer.
- Center Lines
  - Broken yellow, 4 inch wide 10-foot segments with 30-foot gaps.
  - Solid yellow, 4 inch wide. These lines separate adjacent-opposite direction traffic lanes. Double lines shall be spaced 4 inches apart.
- Lane Lines
  - Broken white, 4 or 6 inches wide 10-foot segments with 30-foot gaps.
  - Solid white, 4 or 6 inches wide. These lines separate adjacent-same direction traffic lanes. A solid line may be used to discourage lane changing, while two parallel solid white lines are required to prohibit lane changing.
- Edge Lines
  - Solid white or yellow edge lines shall be 4 or 6 inches wide. Yellow edge lines shall be used only for left edge, in the direction of travel of divided streets and highways (separated by other than a painted median) and one-way roadways (including ramps).
  - Edge lines are not continued through intersections and are not broken for driveways. Care must be taken to avoid edge line appearing as lane line along roadways with wide shoulders and/or closely spaced driveways.
- Dotted Line Extensions  
Broken white, width matching the line being extended 2-foot segments with 4-foot gaps. These lines are used to delineate the extension of a line through an intersection or interchange area.
- Lane Drop / Aux Lines  
Broken white, 8 inch wide 3-foot segments with 12-foot gaps. These lines should begin 2600 feet in advance of the theoretical gore point to distinguish the lane drop from a continuous lane.
- Dashed lane lines  
Broken white, 4 or 6 inches wide 3-foot segments with 12-foot gaps. Line width shall match the adjacent lane line. These lines separate a through lane from an adjacent deceleration or acceleration lane.
- Channelizing Lines  
Solid white, 8 inch wide. These lines are used with acceleration-deceleration lanes, pavement width transitions, and left-right turn slots or islands.

\* The channelizing line may be extended 300 feet (typical) upstream from the theoretical gore. Final length depends on site conditions.

(Continued on Sheet No. 2)

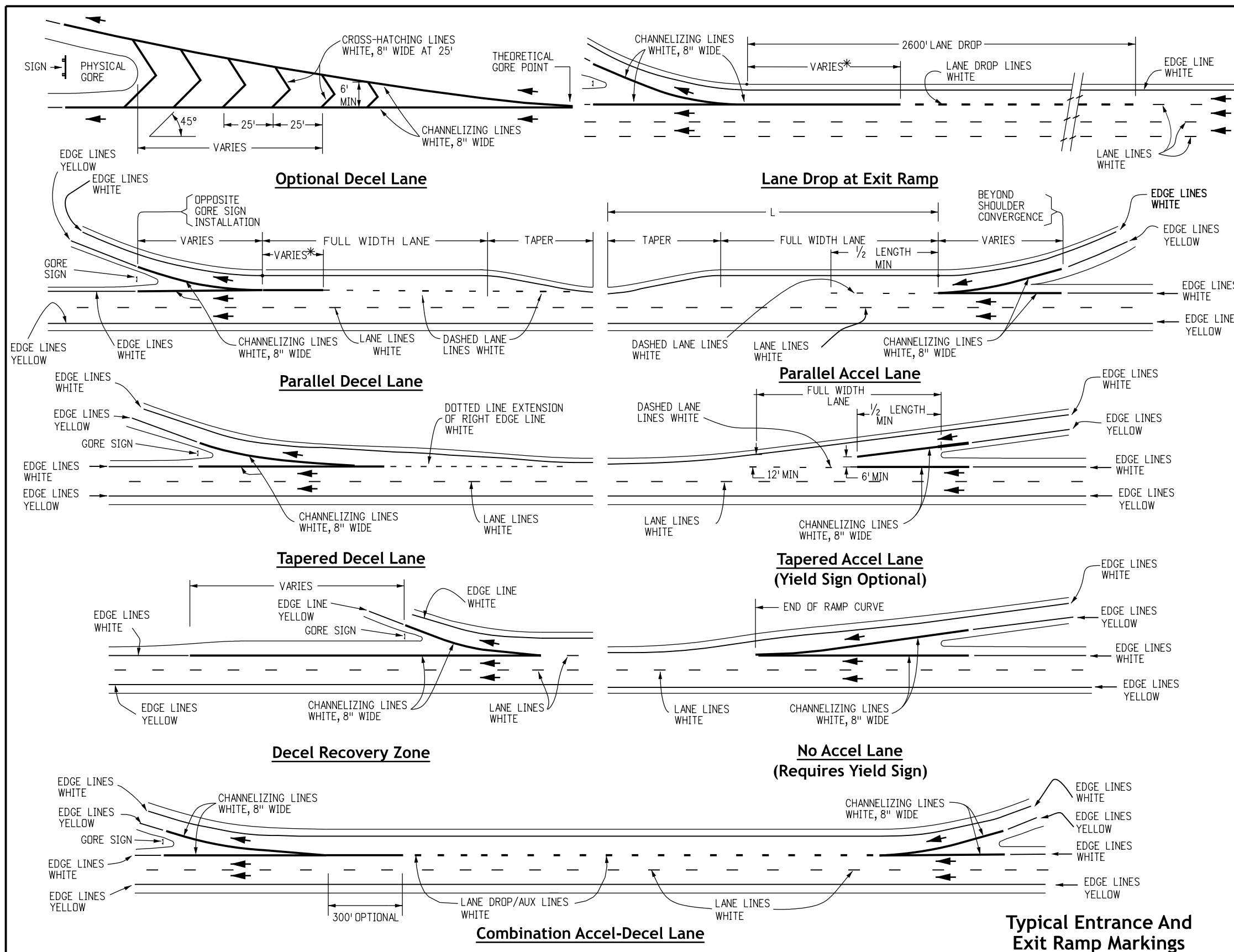

## Typical Entrance And Exit Ramp Markings

Computer File Information	
Creation Date:	07/04/12
Created By:	SCL
Last Modification Date:	07/01/26
Last Modified By:	NRR
CAD Ver.:	ORD 10.12 Scale: Not to Scale Units: English

Sheet Revisions	
Date:	Comments

**Colorado Department of Transportation**  
**Traffic Safety & Engineering Services**  
 2829 West Howard Place  
 Denver, CO 80204  
 EB

**Pavement Markings**  
 Issued by the Traffic Safety & Engineering Services: July 01, 2026

**Standard Plan No.**  
**S-627-1**  
**Standard Sheet No. 1 of 11**  
 Project Sheet Number:

## General Notes

(Continued from Sheet No. 1)

10. Cross-Hatching Lines
  - a. Solid white or yellow, 8 inches wide-45 degree diagonal, spaced at 25 feet intervals. These lines are optional and may be placed at locations indicated on the plans or determined by the Engineer. Yellow shall be used for painted medians or pavement width transitions only.
  - b. Optional diagonal shoulder markings shall be solid white, 8 inches wide, spaced at intervals of 20 feet minimum to 100 feet maximum.
11. Parking Lines
 

Solid white, 3 inches wide-diagonal or parallel as shown on the plans or directed by the Engineer.
12. Stop Lines
 

Solid white, 24 inches wide-extend parallel to intersected roadway across all approach lanes or as indicated at locations on the plans. Locate at the desired stopping point, not more than 30 feet, nor less than 4 feet from the nearest edge of the intersected traffic lane.
13. Yield Lines
  - a. Solid white, the individual triangles comprising yield lines shall have a base of 1 to 24 inches wide and a height equal to 1.5 times the base and shall be parallel to the intersected roadway across all approach lanes or as indicated at locations on the plans.
  - b. The space between each triangle shall be 3 to 12 inches.
14. Crosswalk Lines
  - a. Solid white, 12 inches wide for transverse line type extend across entire width of pavement. If no advance stop line is provided, increase the width of the crosswalk lines to 24 inches. The distance between the lines is usually determined by the width of the sidewalks connected, in any case this shall not be less than 6 feet.
  - b. Complicated and/or channelized intersections and mid-block crosswalks shall be solid white, 12 inches to 24 inches wide and 8 to 10 feet long for longitudinal line type as detailed in the plans or as directed by the Engineer.
15. Word, Arrow and Symbol markings
 

All letters, arrows and symbols shall be in conformance with "The Standard Alphabets for Highway Signs and Pavement Markings" adopted by the Federal Highway Administration.
16. Merging Taper Length
 

L = Minimum Length of Taper.  
S = Design speed for new construction or numerical value of the posted speed limit of the 85th Percentile Speed of existing traffic.  
W = Width Transitioned.

Formula: For speeds 45 mph or more,  $L = S \times W$

For speeds 40 mph or less,  $L = \frac{WS^2}{60}$
17. Transition Lines
 

Solid yellow, 8 inches wide. these lines are used where additional emphasis or visibility is desirable at pavement width transitions. place at locations indicated on the plans or as directed by the Engineer.
18. Speed Measuring Marking
 

Solid white, 24 inches extend 4 feet from outside of edge lines on shoulders.
19. All spacing is determined center on center except for double lines.

### Note:

AP = Advance placement distance from the lane ends sign (W4-2) to the beginning of the merging taper. See Section 2C of the MUTCD for advance placement distances.

### Legend

→ Direction Of Travel

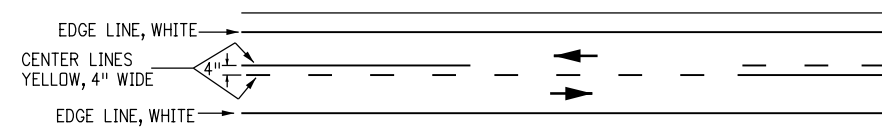

**Two Lane Highway**

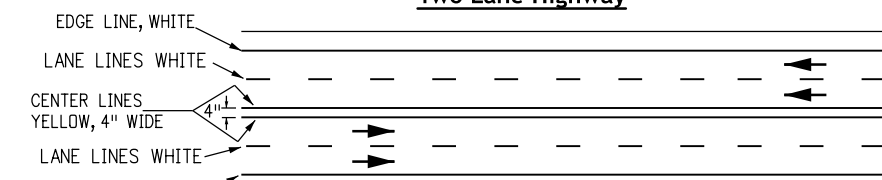

**Four Lane Undivided Highway**

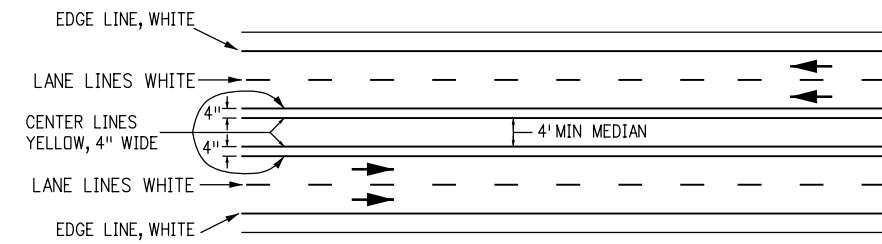

**Four Lane Paint Divided Highway**

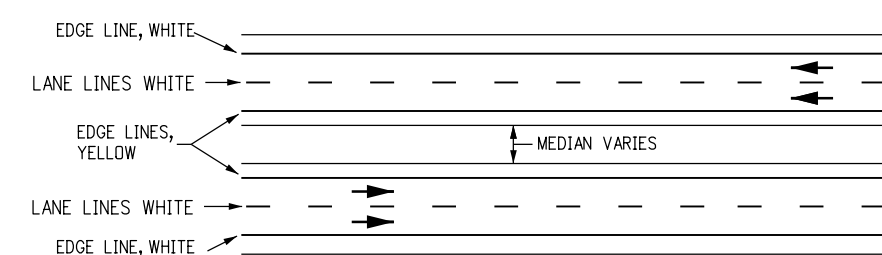

**Four Lane Divided Highway**

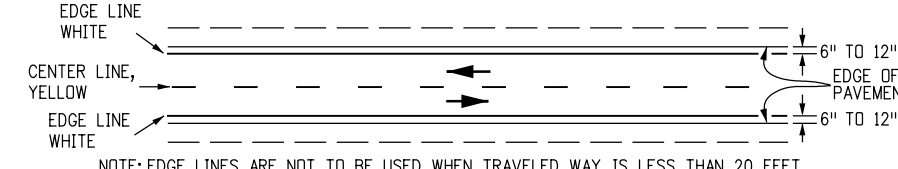

**No Shoulder Or Unsurfaced Shoulder**

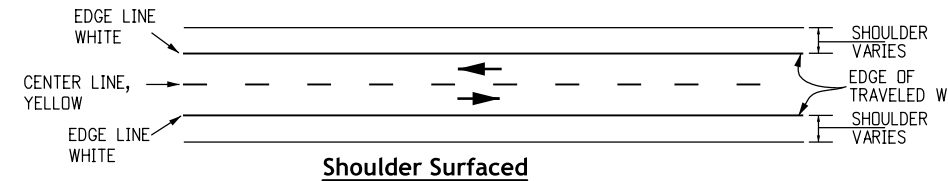

**Shoulder Surfaced**

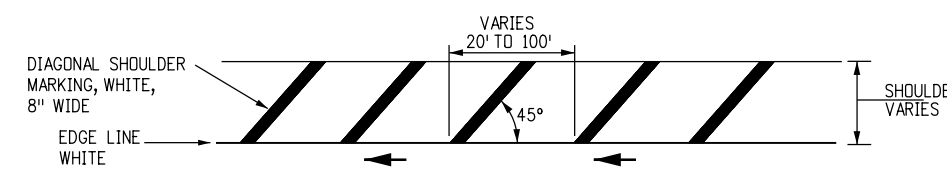

**Edge Line With Optional Diagonal Shoulder Marking**

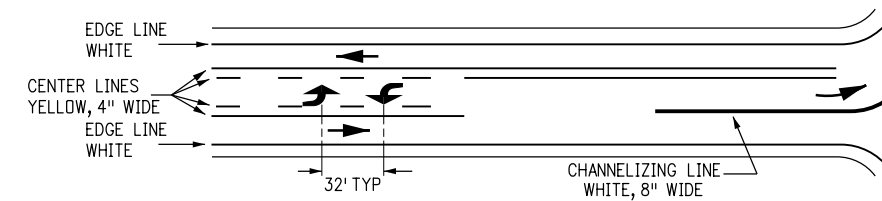

**Typical Two Way Left Turn Lane**

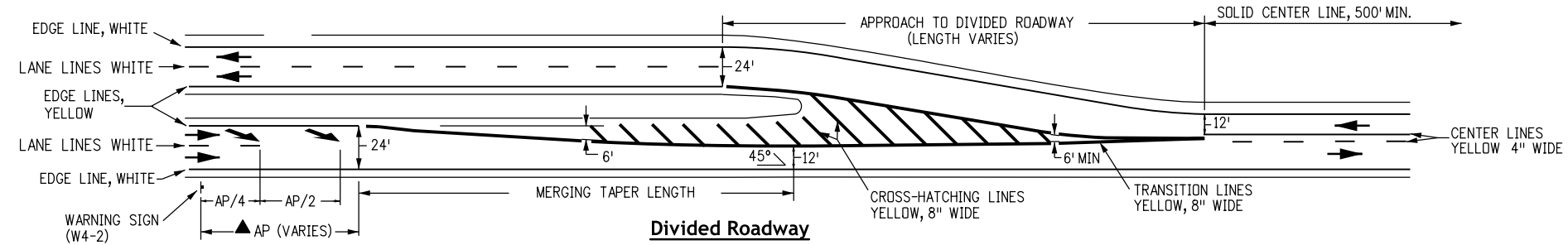

**Divided Roadway**

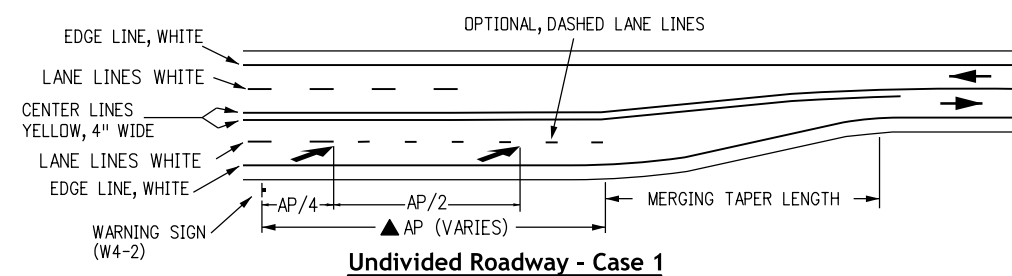

**Undivided Roadway - Case 1**

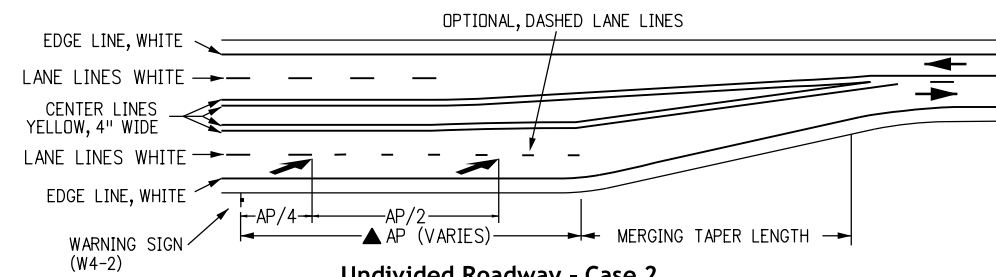

**Undivided Roadway - Case 2**

## Typical Pavement Width Transition Markings

Computer File Information	
Creation Date:	07/04/12
Created By:	KEN
Last Modification Date:	07/01/26
Last Modified By:	NRR
CAD Ver.:	ORD 10.12 Scale: Not to Scale Units: English

Sheet Revisions	
Date:	Comments

**Colorado Department of Transportation**

**Traffic Safety & Engineering Services**

2829 West Howard Place  
Denver, CO 80204

EB

**Pavement Markings**

Issued by the Traffic Safety & Engineering Services: July 01, 2026

**Standard Plan No.**

**S-627-1**

Standard Sheet No. 2 of 11

Project Sheet Number:

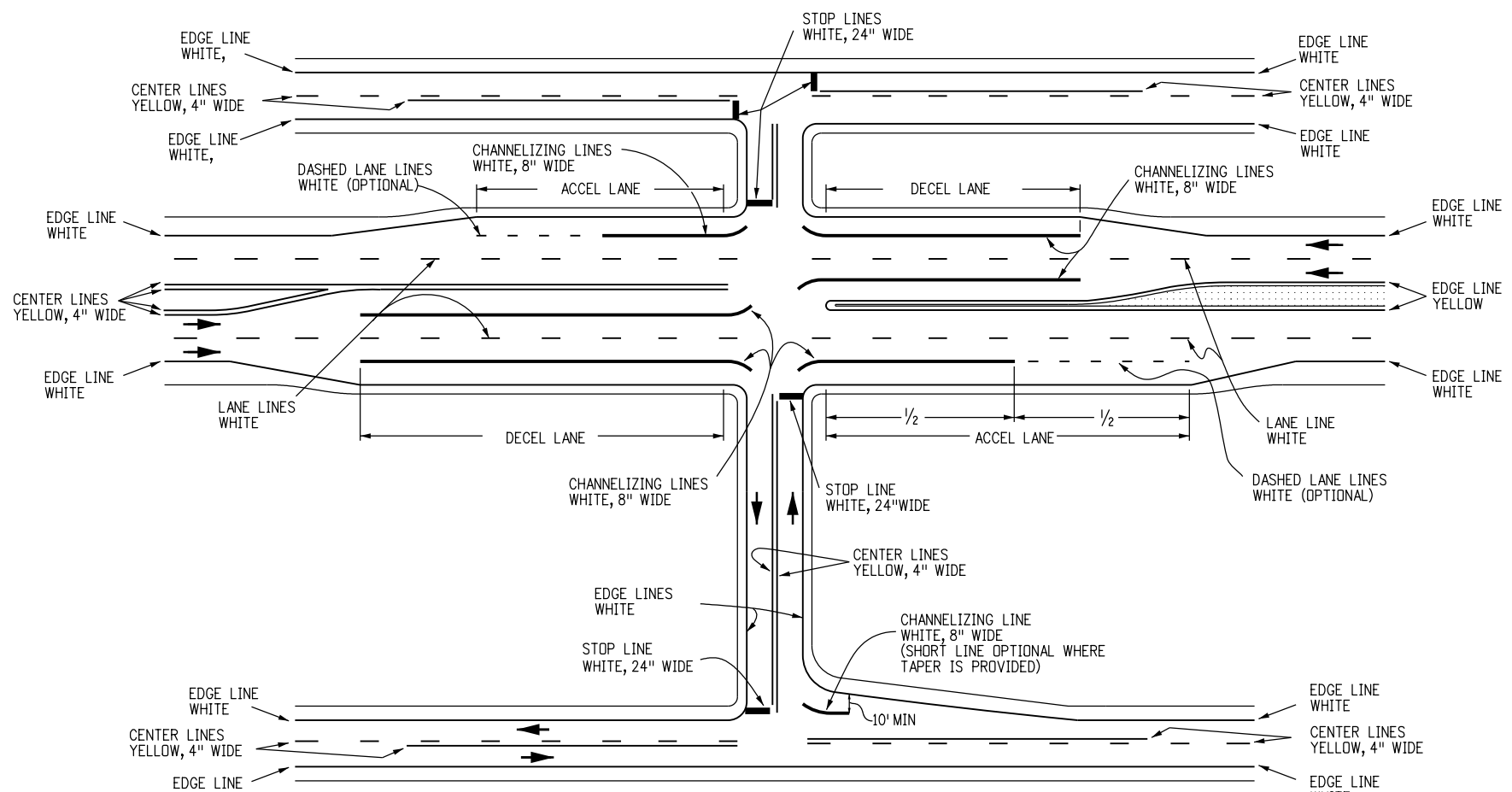

**Typical Intersection Markings**

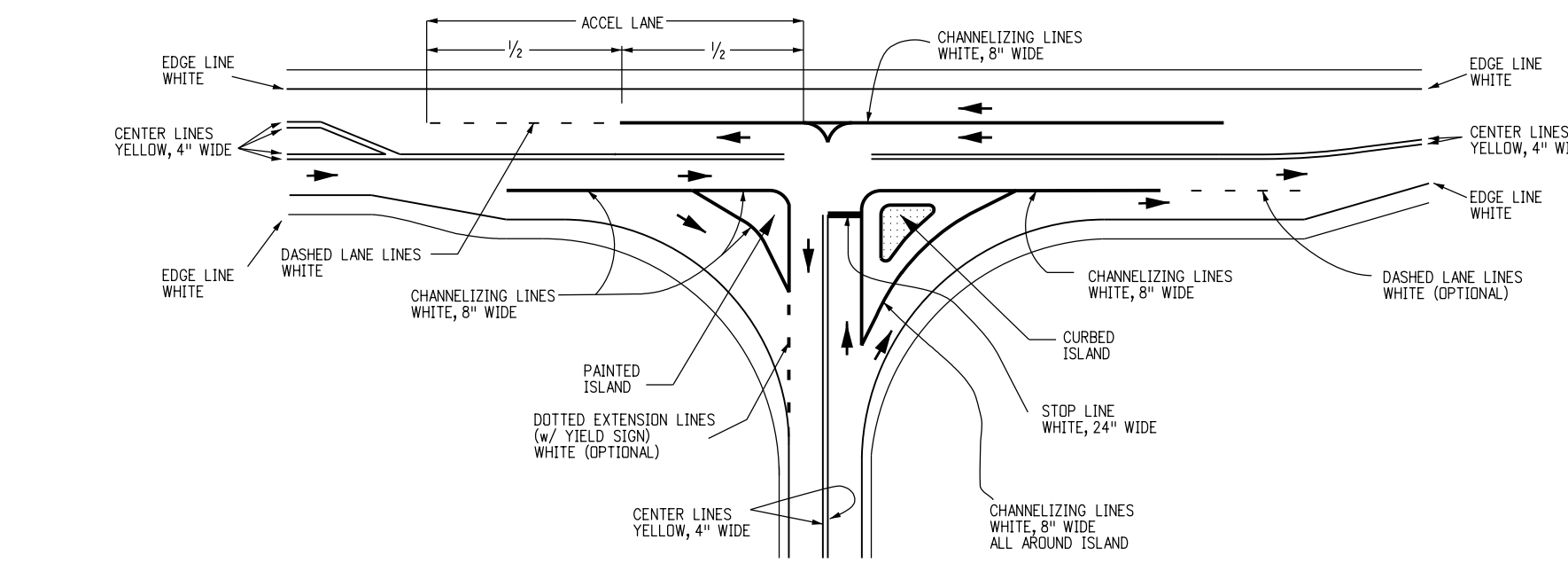

**Typical Island Markings**

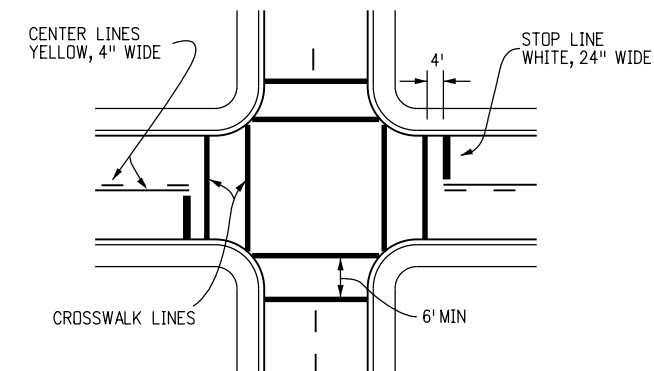

**Typical Transverse Line Crosswalk Markings**

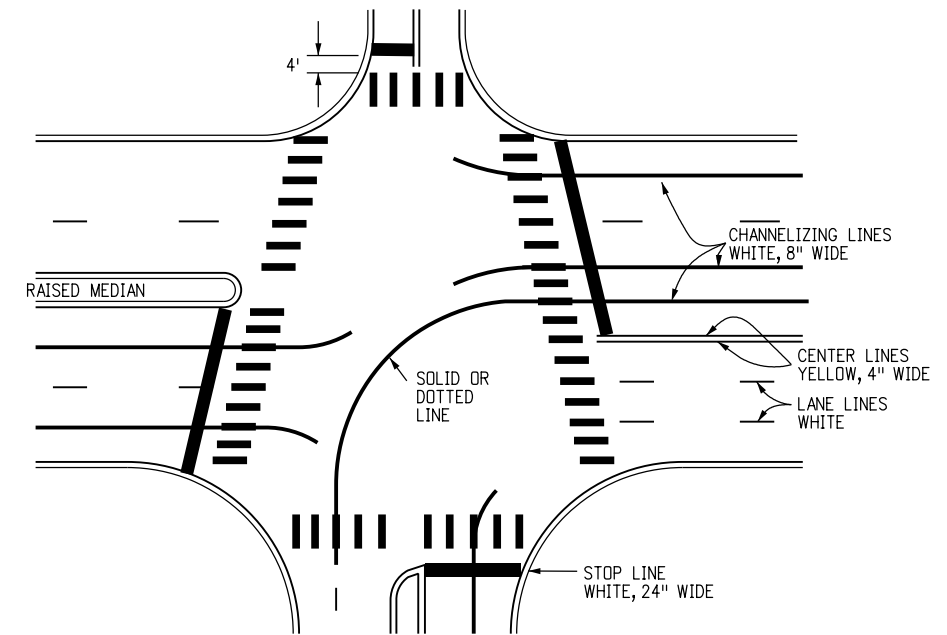

**Typical Continental Crosswalk Markings**

**Crosswalk Line Detail**



**Legend**



**Continental Crosswalk Notes**

- Center crosswalks on curb ramps, if such ramps are not provided, center on signal poles wherever practical.
- Center crosswalks on edge lines, lane lines and channelizing lines.
- Center crosswalks between adjacent lines.
- Markings shall not be within wheel path of vehicles.
- Center on extended flow line.
- Lines and spaces to approximate adjacent pattern.

**Intersections, Islands and Crosswalks**

Computer File Information	
Creation Date:	07/04/12
Created By:	JSW
Last Modification Date:	07/01/26
Last Modified By:	NRR
CAD Ver.:	ORD 10.12 Scale: Not to Scale Units: English

Sheet Revisions	
Date:	Comments

**Colorado Department of Transportation**  
**Traffic Safety & Engineering Services**  
 2829 West Howard Place  
 Denver, CO 80204  
 EB

**Pavement Markings**  
 Issued by the Traffic Safety & Engineering Services: July 01, 2026

Standard Plan No.
<b>S-627-1</b>
Standard Sheet No. 3 of 11
Project Sheet Number:

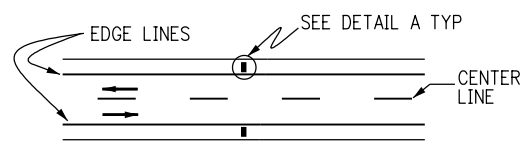

**Two - Way Roadway**

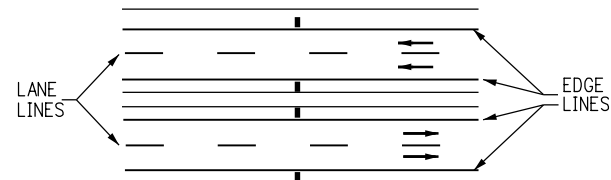

**Multi - Lane Divided Highway**

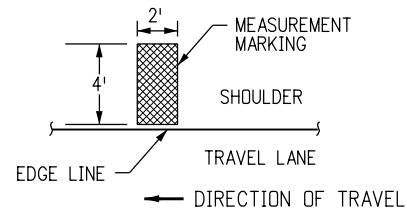

**Detail A**

**Typical Speed Measurement Marking**

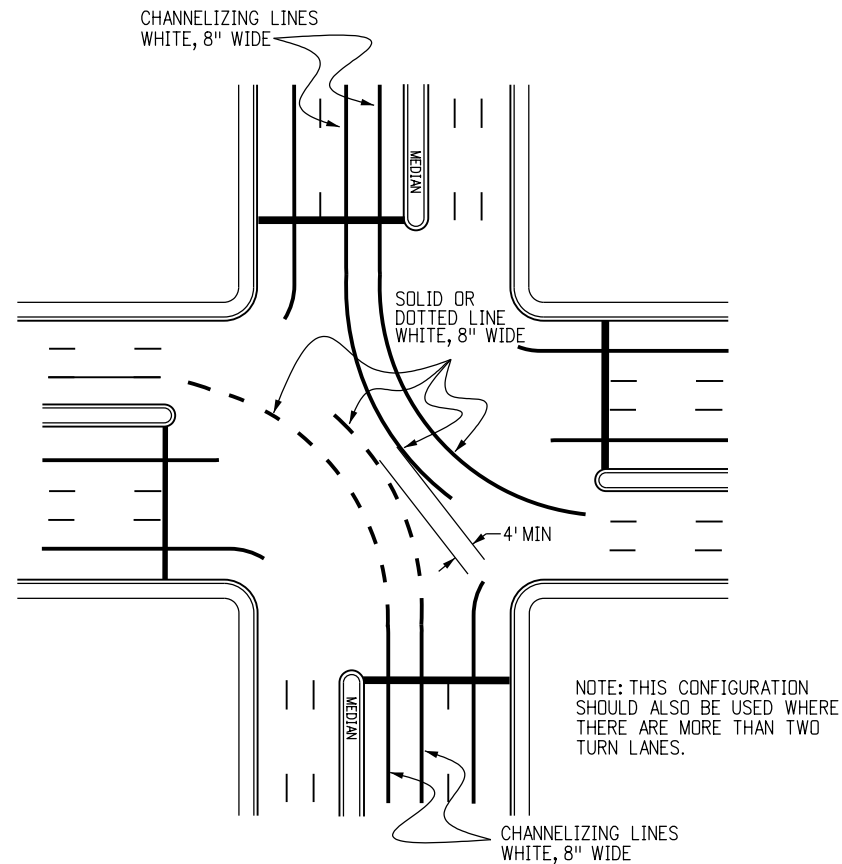

**Typical Double Left Turn Markings**

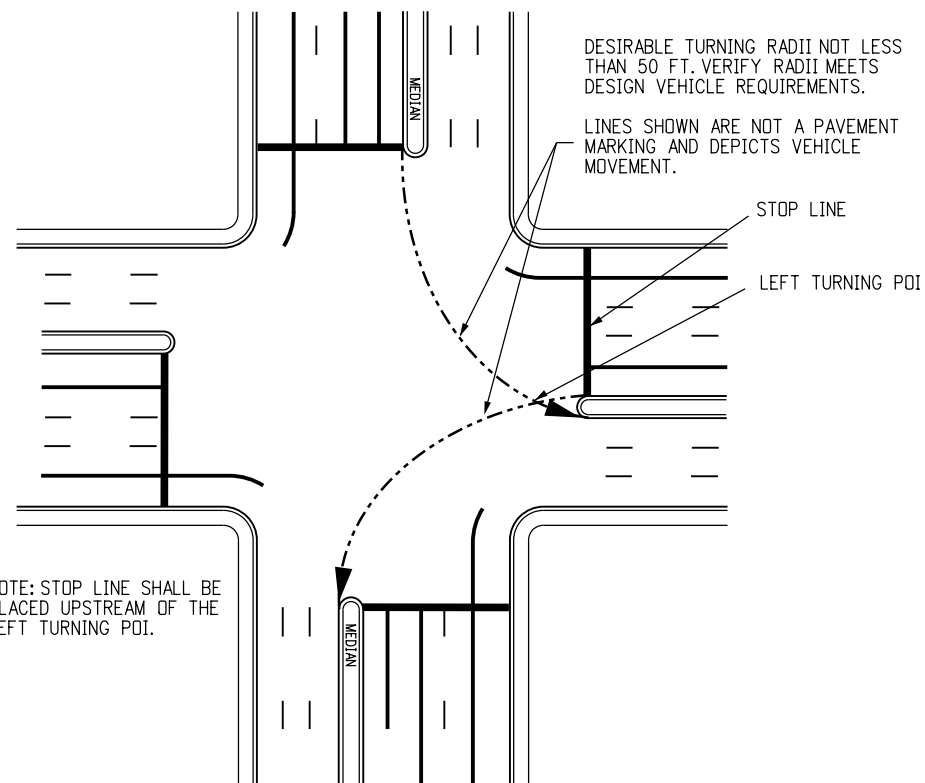

**Typical Stop Line Placement**

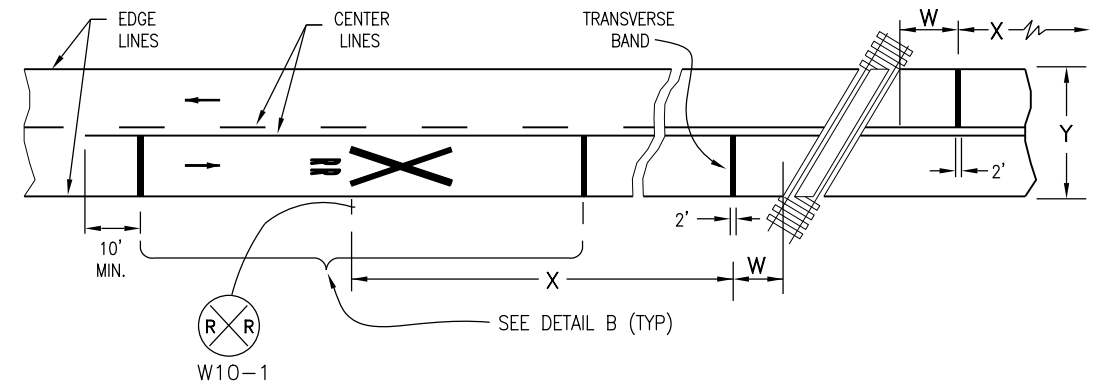

**Typical Pavement Marking at Railroad Crossing**

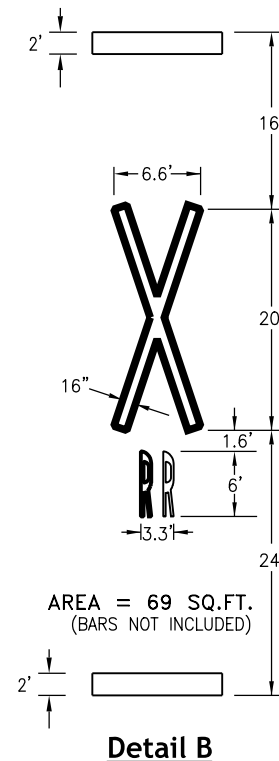

- W = Approximately 15 ft. (stop line should be 8' in advance of active traffic control systems; i.e., automatic gates and/or flashing signals).
- X = The distance from the railroad crossing marking to the nearest track will vary according to the approach speed and the sight distance of the vehicular traffic approaching, but not less than 100 ft. (Reference Note 1).
- Y = On multi-lane roads the transverse bands should extend across all approach lanes, and individual railroad symbols should be used in each approach lane.

**Notes**

1. The warning sign shall be placed according to the warning sign placement table in the MUTCD (Chapter 2C, Table 2C-3). If conditions do not allow placement according to the table, it shall be as approved by the Engineer.
2. For railroad symbol details, refer to "The Standard Alphabets for Highway Signs and Pavement Markings", adopted by the Federal Highway Administration.

Computer File Information	
Creation Date:	07/04/12
Created By:	SCL
Last Modification Date:	07/01/26
Last Modified By:	NRR
CAD Ver.:	ORD 10.12 Scale: Not to Scale Units: English

Sheet Revisions	
Date:	Comments

**Colorado Department of Transportation**

**Traffic Safety & Engineering Services**

2829 West Howard Place  
Denver, CO 80204

EB

**Pavement Markings**

Issued by the Traffic Safety & Engineering Services: July 01, 2026

Standard Plan No.
S-627-1
Standard Sheet No. 4 of 11
Project Sheet Number:

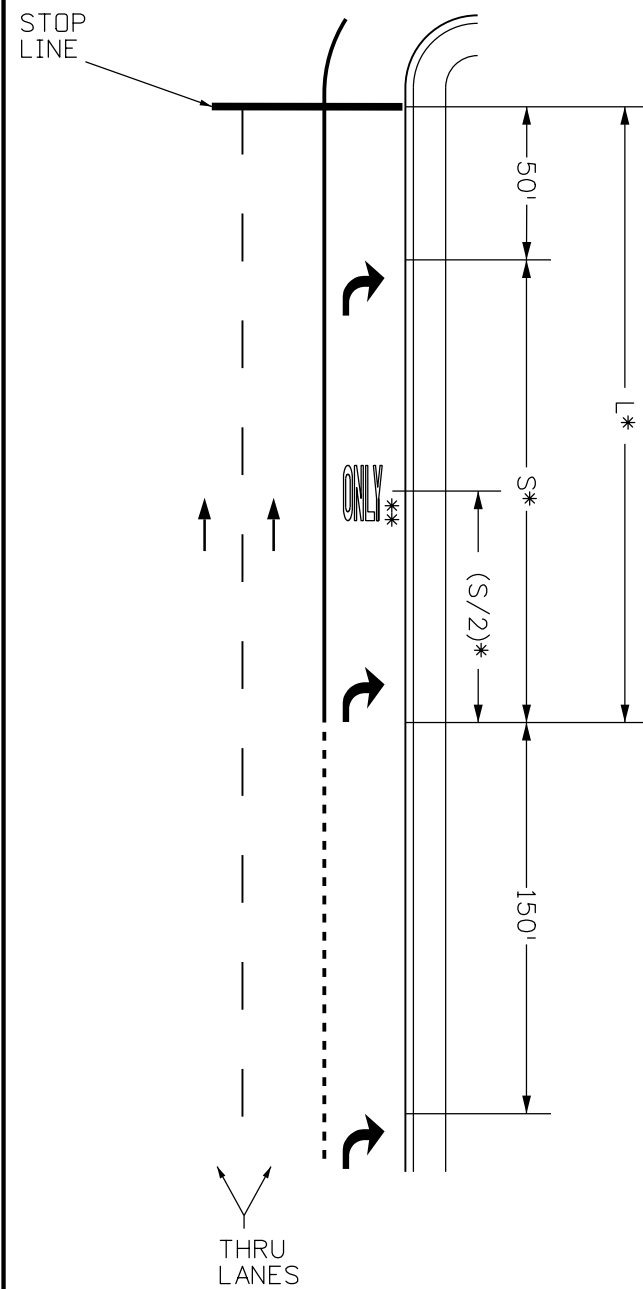

**Lane Drop**

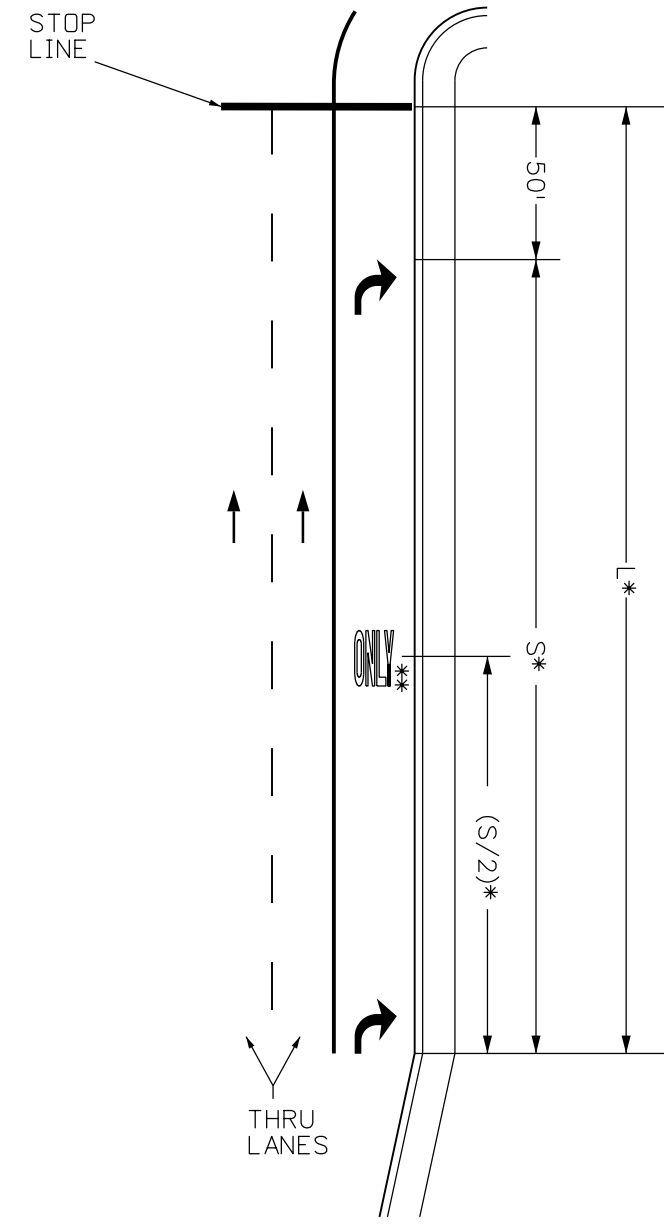

**Pocket Lane**

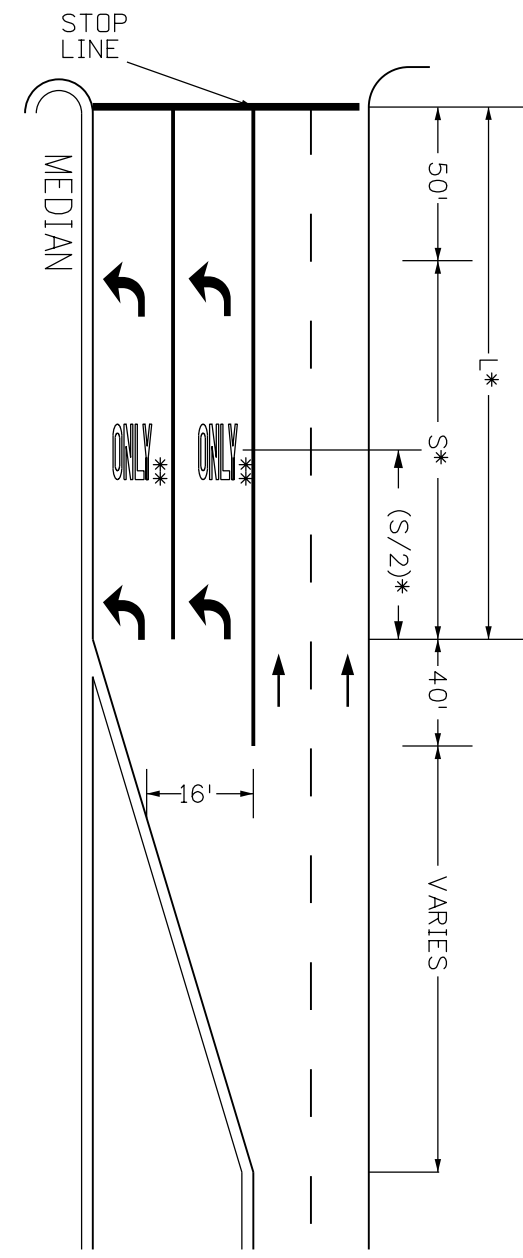

**Double Turning**

**Arrow Placement Notes**

1. The spacing, in the table applies to left and right turn lanes.
- \* 2. The 'ONLY' word marking is optional. Contact the region traffic engineer for guidance.
3. When one (1) arrow is used, it shall be placed at the beginning of the full width turn lane, otherwise use the table below for arrow placement.

LENGTH (L)	LEFT AND RIGHT TURN ARROW		NO. OF 'ONLY' PER LANE
	NO. OF ARROWS PER LANE	SPACING (S)	
L < 200'	1	NA	NA
200' - 350'	2	EVENLY	1
350' - 650'	3	SPACED	2
650' - 950'	4	BETWEEN	3
950' ≤	≥5	150'-300'	≥4

\* L (length) and \* S (spacing) provided in the table above will help determine the number of arrows and only markings needed per lane.

**Legend**  
 Direction of Travel

**Arrow Placements at Intersections**

Computer File Information	
Creation Date:	07/04/12
Created By:	MKB
Last Modification Date:	07/01/26
Last Modified By:	NRR
CAD Ver.: ORD 10.12 Scale: Not to Scale Units: English	

Sheet Revisions	
Date:	Comments

**Colorado Department of Transportation**  
**Traffic Safety & Engineering Services**  
 2829 West Howard Place  
 Denver, CO 80204  
 EB

**Pavement Markings**  
 Issued by the Traffic Safety & Engineering Services: July 01, 2026

Standard Plan No.
<b>S-627-1</b>
Standard Sheet No. 5 of 11
Project Sheet Number:

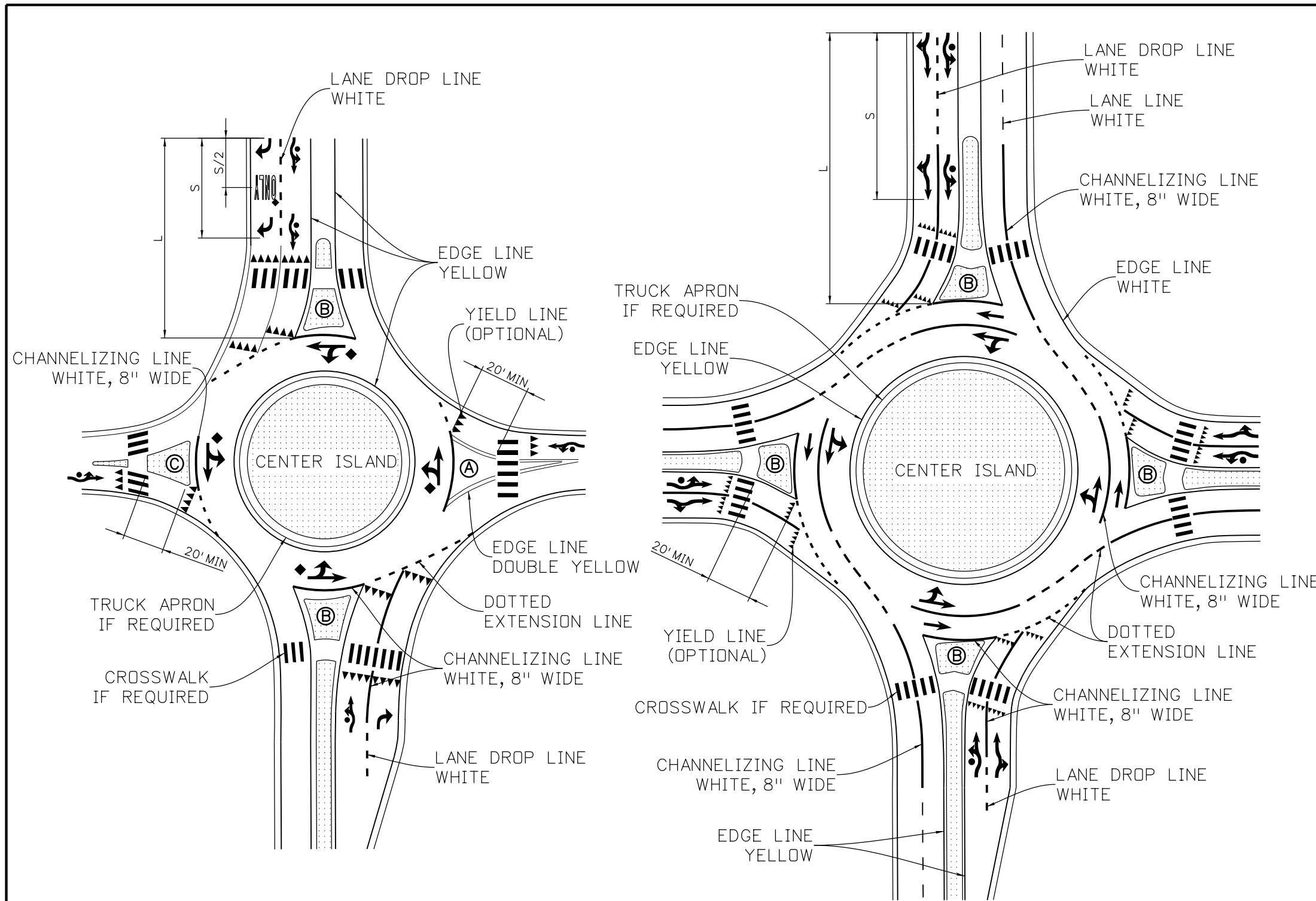

**Single Lane Roundabout (Typical)**

Note: Splitter island may be formed by two yellow lines, raised non-mountable, or raised mountable.

**Two Lane Roundabout (Typical)**

**Roundabout Pavement Markings**

**Notes**

1. Unless shown in this standard, the widths of pavement markings shall match the largest line width of the adjacent facilities.
2. Pavement marking lines along non-mountable splitter islands are optional.
3. Normal lane-use arrows shall be used in the roundabout.
4. Normal or fish-hook lane-use arrows may be used on the approach. Advanced signing shall match the pavement marking used.
  - a. When one (1) arrow is used on the approach, it shall be placed at the beginning of the channelizing line. otherwise, use table below.

LENGTH (L)	LEFT AND RIGHT TURN ARROW		NO. OF 'ONLY' PER LANE
	NO. OF ARROWS PER LANE	SPACING (S)	
L < 200'	1	NA	NA
200' - 350'	2	EVENLY	1
350' - 650'	3	SPACED	2
650' - 950'	4	BETWEEN	3
950' ≤	≥5	150'-300'	≥4

5. The inscribed oval is optional and may be combined with the lane-use arrow in the left-most lane.
6. See Sheet 10 for lane-use arrow dimensions.
7. Yield lines utilized at crosswalk shall be placed 20 to 50 feet in advanced of the crosswalk.

**Legend**

- (A) Splitter Island Formed By Two Yellow Lines
- (B) Raised Non-mountable Splitter Island
- (C) Mountable Splitter Island
- ◆ Optional

Computer File Information	
Creation Date:	07/04/12
Created By:	AV
Last Modification Date:	07/01/26
Last Modified By:	NRR
CAD Ver.:	ORD 10.12 Scale: Not to Scale Units: English

Sheet Revisions	
Date:	Comments

**Colorado Department of Transportation**

**Traffic Safety & Engineering Services**

2829 West Howard Place  
Denver, CO 80204

EB

**Pavement Markings**

Issued by the Traffic Safety & Engineering Services: July 01, 2026

**Standard Plan No.**

**S-627-1**

Standard Sheet No. 6 of 11

Project Sheet Number:

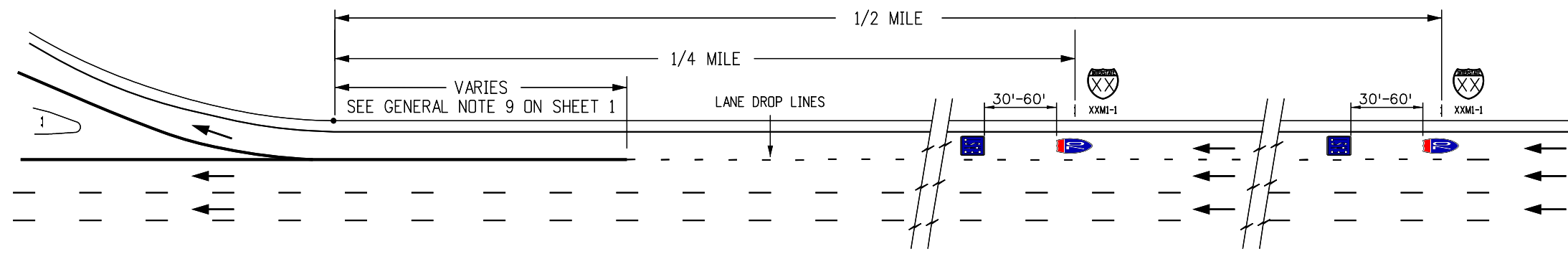

**Typical Shield Placement**

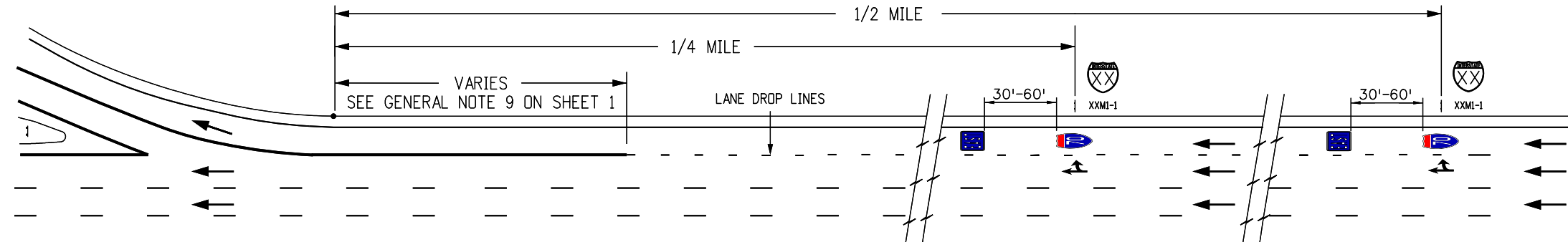

**Typical Shield & Option Arrow Pavement Marking Placement**

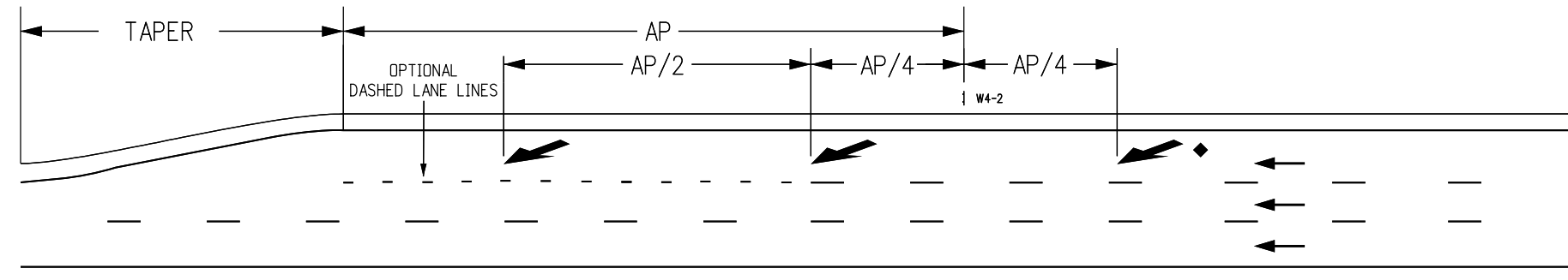

**Lane Reduction Markings**

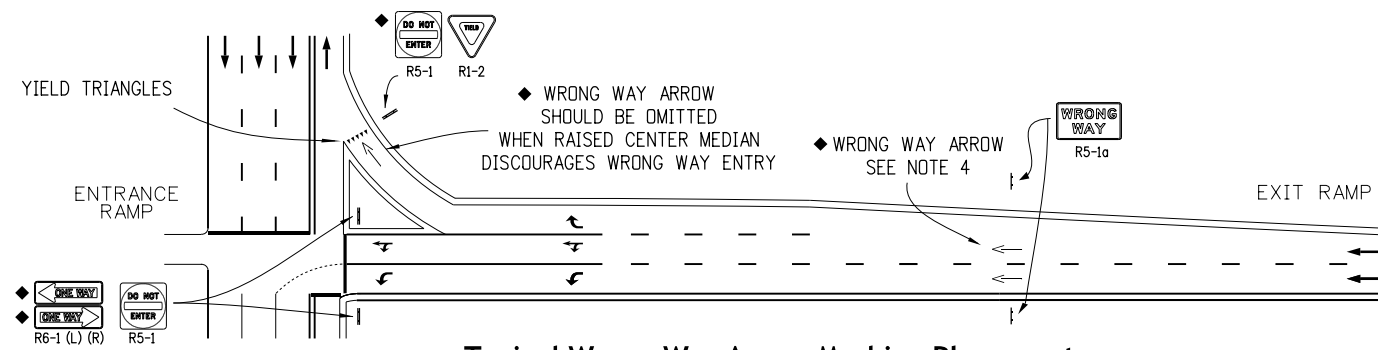

**Typical Wrong Way Arrow Marking Placement**

**Shield Layout Detail**

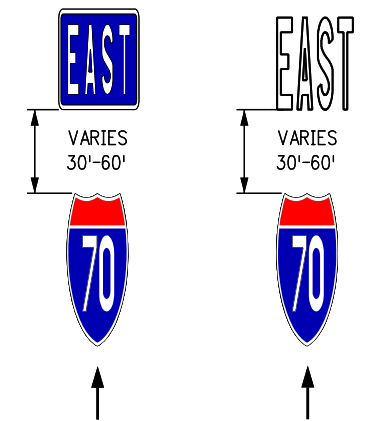

**Notes**

1. Shield and cardinal direction pavement markings are optional and shall be installed as shown in the plans.
2. Lane-reduction arrow markings are not required for acceleration lanes. Lane-reduction arrow markings may be installed in long acceleration lanes as shown in the plans or as directed by the Engineer.
3. Lane-reduction arrow markings are optional for speeds less than 45 mph.
4. Wrong way arrow markings may be installed as directed by the Engineer. If used, wrong way arrow markings shall be the last arrow marking in sequence from the intersection to the beginning of the exit ramp.
5. Refer to Sheet 5 for lane use arrow placement at intersections. See arrow details on Sheets 9 and 10.
6. See Note 2 "Cardinal Directions" on Sheet 11

**Legend**

- ← Direction of Travel
- AP = Advance placement distance from the lane ends sign (W4-2) to the beginning of the merging taper. See Section 2C of the MUTCD for advance placement distances.
- ◆ Optional

**Typical Arrow and Shield Pavement Markings**

<b>Computer File Information</b>		<b>Sheet Revisions</b>		<b>Colorado Department of Transportation</b>  <b>Traffic Safety &amp; Engineering Services</b> 2829 West Howard Place Denver, CO 80204 EB	<b>Pavement Markings</b>	<b>Standard Plan No.</b>	
Creation Date: 07/04/12		Date:	Comments			<b>S-627-1</b>	
Created By: MKB						Standard Sheet No. 7 of 11	
Last Modification Date: 07/01/26							
Last Modified By: NRR							
CAD Ver.: ORD 10.12 Scale: Not to Scale Units: English				Project Sheet Number:			

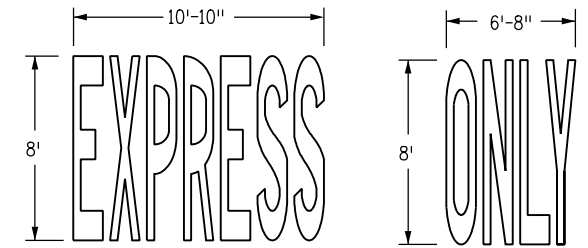
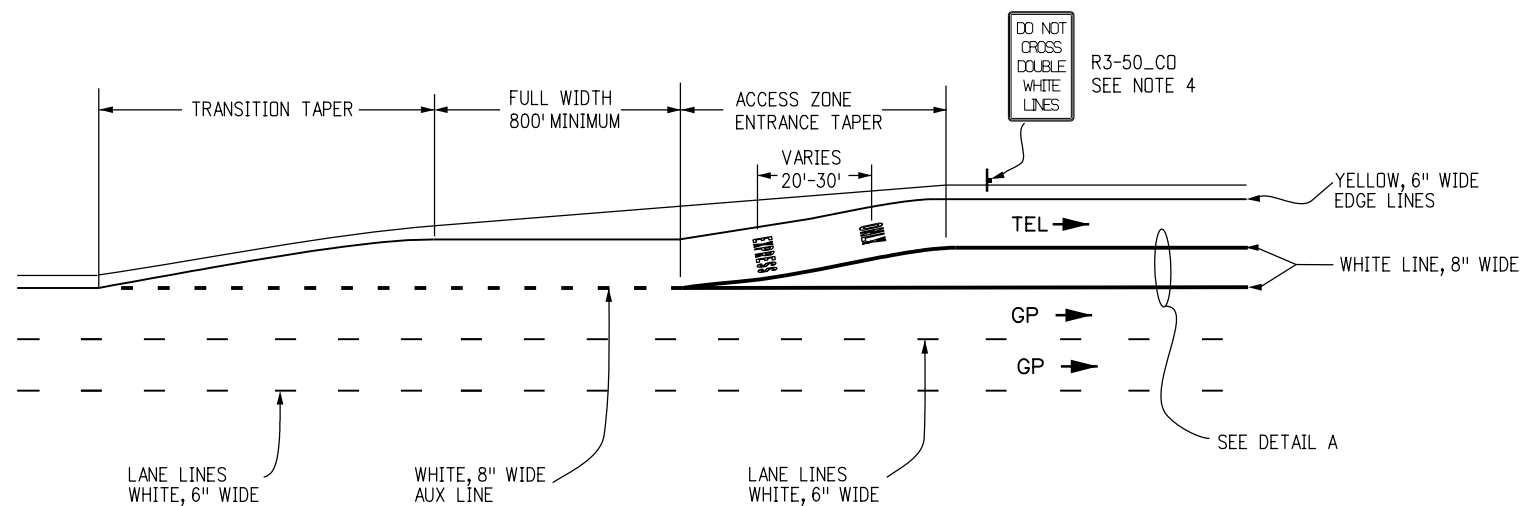

**Typical Entrance Marking for Buffer Width 12' and Where Buffer Crossing is Prohibited**

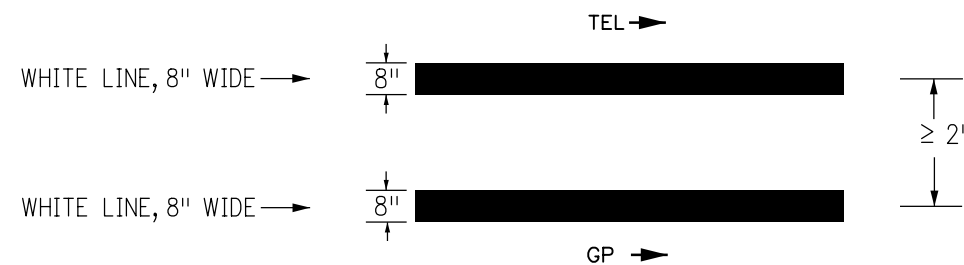

**Detail A**

**Notes**

- For transition taper use 25:1 ratio.
- For access zone entrance taper length use:
  - $L = S \times W$
  - L = Minimum Length Of Taper
  - S = Design speed for new construction or numerical value of the posted speed limit
  - W = Width Transitioned
- If buffer space is wider than 4 feet, chevron markings should be installed (see MUTCD Section 3B.25, 3E.02, and Figure 3E-2(A)).
- For each section prohibiting entering and exiting movements, the R3-50\_CO sign shall be installed within 300 feet of the start of the express lane. Additional R3-50\_CO signage shall be installed as shown in the plans.
- For each section prohibiting entering and exiting movements, an express only marking should be placed within 50 feet of the start of the express lane.
- Express only markings should supplement the signs.

**Legend**

- TEL - Toll/Express Lane
- GP - General Purpose Lane
- ➔ - Direction Of Travel

**Toll Express Lane Pavement Markings**

<b>Computer File Information</b>		<b>Sheet Revisions</b>		<p><b>Colorado Department of Transportation</b>  <b>Traffic Safety &amp; Engineering Services</b>          2829 West Howard Place          Denver, CO 80204</p>	<p><b>Pavement Markings</b></p>	<b>Standard Plan No.</b>	
Creation Date: 07/04/12		Date:	Comments:			<b>S-627-1</b>	
Created By: EB						Standard Sheet No. 8 of 11	
Last Modification Date: 07/01/26						Project Sheet Number:	
Last Modified By: NRR							
CAD Ver.: ORD 10.12 Scale: Not to Scale Units: English				EB	Issued by the Traffic Safety & Engineering Services: July 01, 2026		

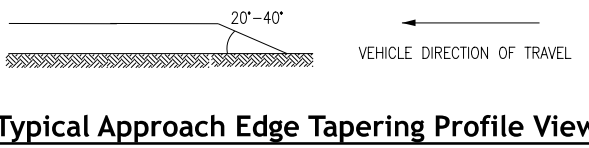
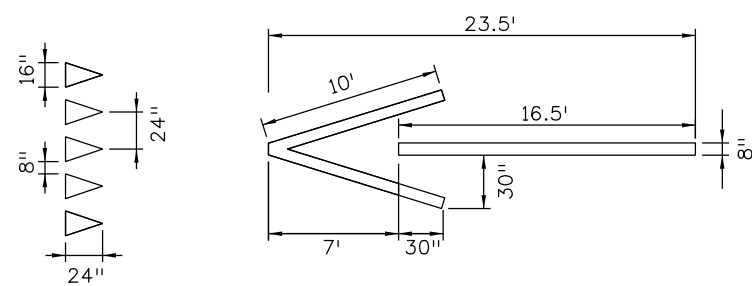
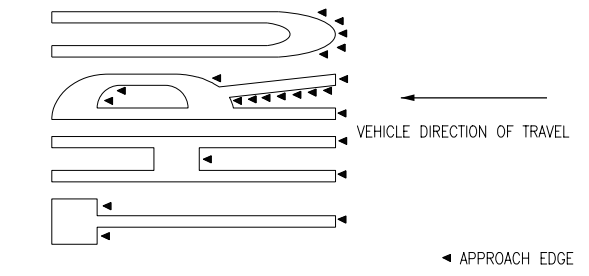
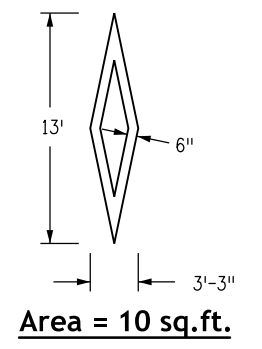
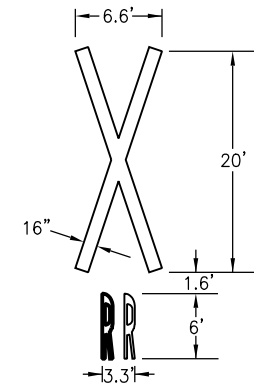
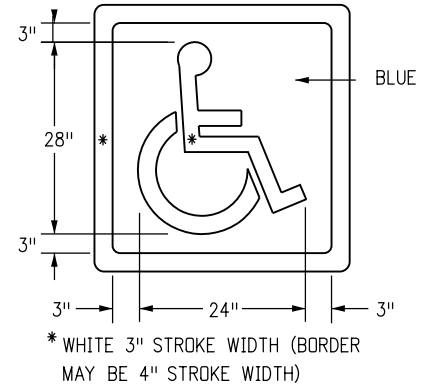
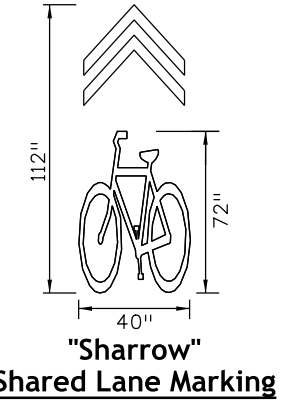
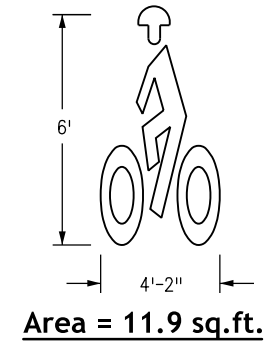
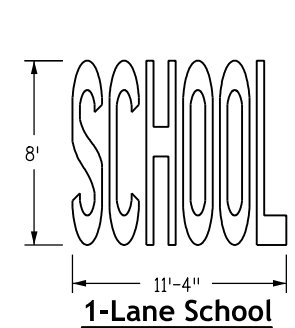
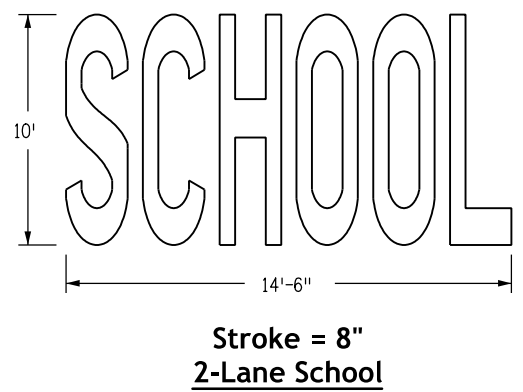
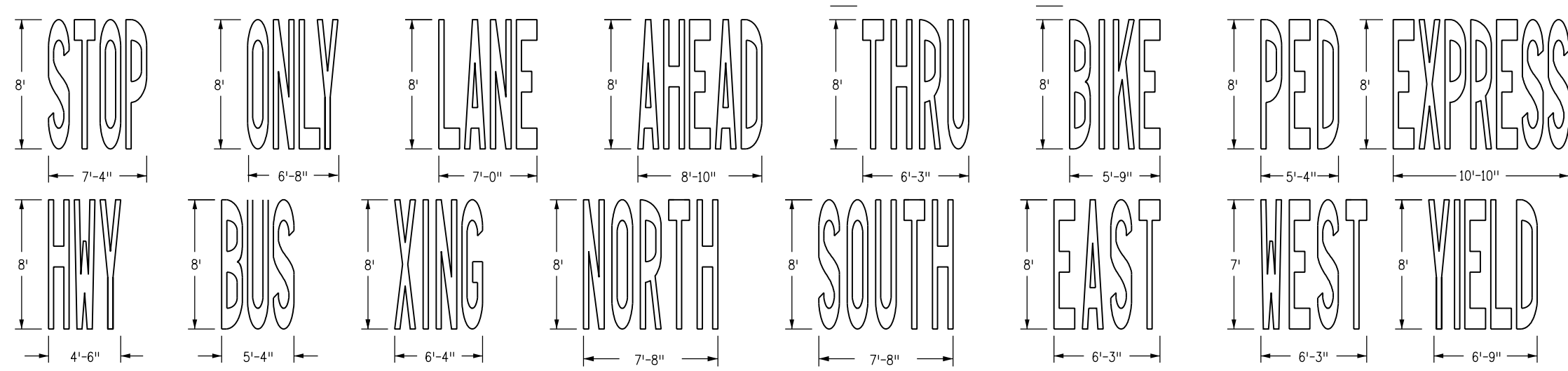

**Word and Symbol Notes**

1. If height is increased or decreased then all measurements change proportionately. Example: "H" measurement for stop is reduced to 4 feet from 8 feet then square feet 5.75 (1/4 of 23.0 sq. ft.).
2. Pavement word and symbol markings, transverse and longitudinal (continental) crosswalk lines, and stop lines will be paid for in square feet using their specific bid items.
3. Letter spacing shall be 8 in. except for the letter "A" which is 6 in.
4. Use the marking word "BIKE" if 6 ft. to 8 ft. bike lanes are installed.

**Tapering Notes**

1. All pavement marking approach edges from the vehicle direction of travel shall be tapered using a putty knife or similar tool.

**Designated Payment Areas**

For the following H, W, and S dimensions pay:

<b>H = 4' Words</b>	
Bike - 5.5 sq.ft.	Lane - 6.0 sq.ft.
Only - 6.0 sq.ft.	XING - 5.0 sq.ft.
<b>H = 8' Words</b>	
Stop - 23.0 sq.ft.	XING - 20.0 sq.ft.
Only - 22.5 sq.ft.	Lane - 22.5 sq.ft.
Ahead - 29.0 sq.ft.	Bike - 21.0 sq.ft.
Bus - 18.5 sq.ft.	Hwy - 16.5 sq.ft.
School(1L) - 33.0 sq.ft.	Thru - 22.0 sq.ft.
School(2L) - 85.0 sq.ft.	Ped - 17.5 sq.ft.
North - 30.6 sq.ft.	South - 28.5 sq.ft.
East - 22.1 sq.ft.	West - 23.7 sq.ft.
X With RR - 69 sq.ft.	Express - 41 sq.ft.
Yield - 23 sq.ft.	

**Typical Letter Measurements**

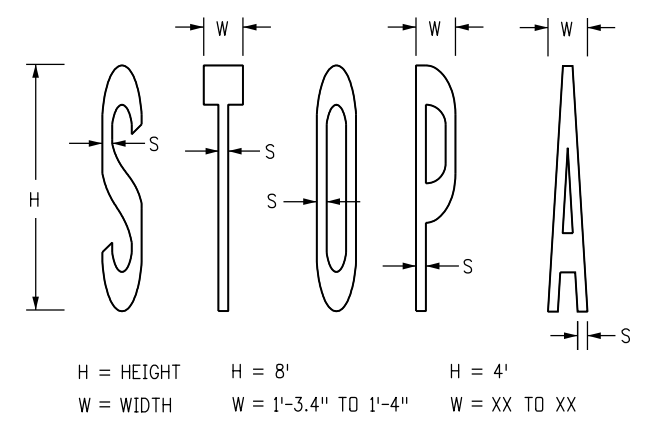

**Pavement Marking Words and Symbols (Page 1)**

Computer File Information	
Creation Date:	07/04/12
Created By:	SCL
Last Modification Date:	07/01/26
Last Modified By:	NRR
CAD Ver.:	ORD 10.12 Scale: Not to Scale Units: English

Sheet Revisions	
Date:	Comments

**Colorado Department of Transportation**

**Traffic Safety & Engineering Services**  
2829 West Howard Place  
Denver, CO 80204

EB

**Pavement Markings**

Issued by the Traffic Safety & Engineering Services: July 01, 2026

Standard Plan No.	
<b>S-627-1</b>	
Standard Sheet No. 9 of 11	
Project Sheet Number:	

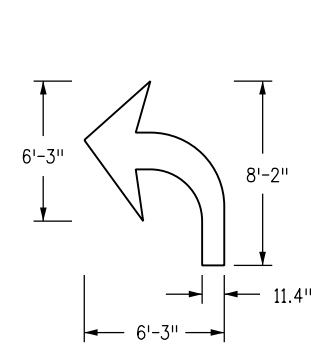

**Area = 16.1 sq.ft.**

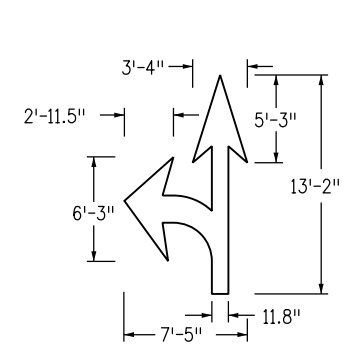

**Area = 27.5 sq.ft.**

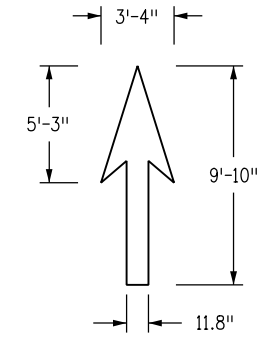

**Area = 12.1 sq.ft.**

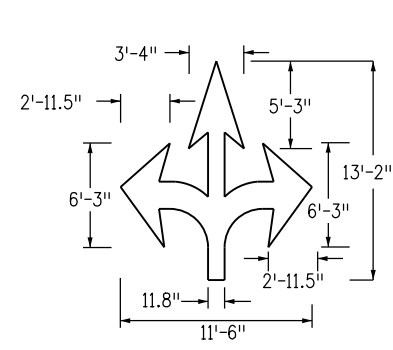

**Area = 39.8 sq.ft.**

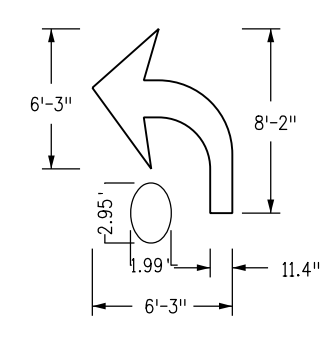

**Area = 20.7 sq.ft.**

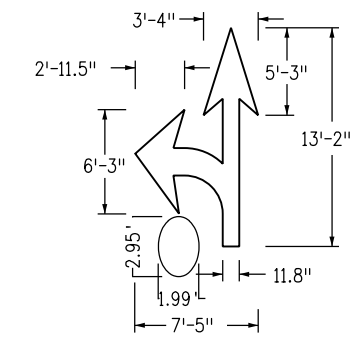

**Area = 32.1 sq.ft.**

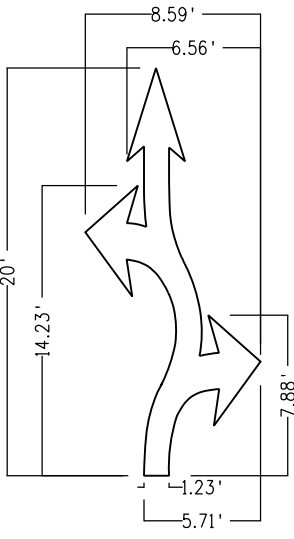

**Area = 41.3 sq.ft.**

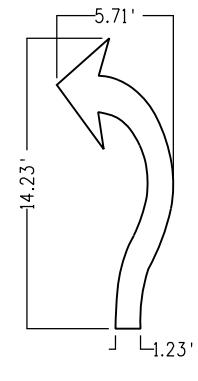

**Area = 23.1 sq.ft.**

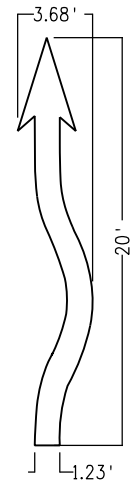

**Area = 26.0 sq.ft.**

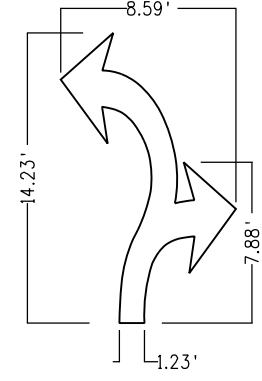

**Area = 30.7 sq.ft.**

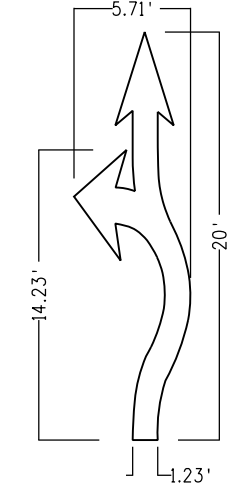

**Area = 33.7 sq.ft.**

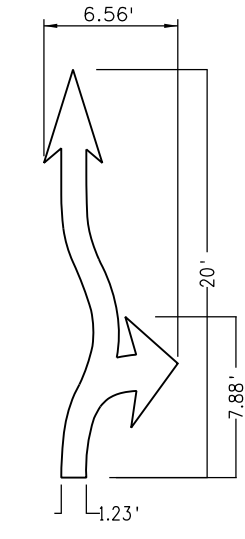

**Area = 33.5 sq.ft.**

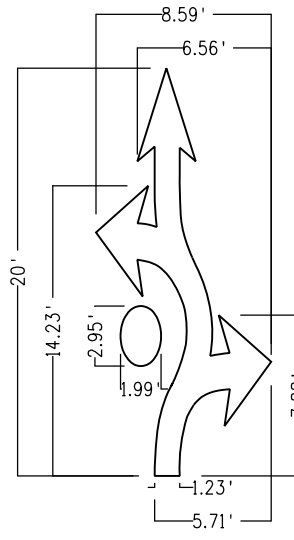

**Area = 45.9 sq.ft.**

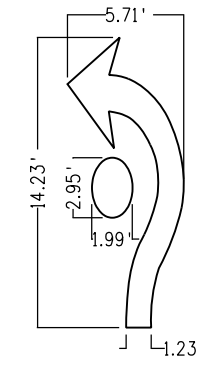

**Area = 27.7 sq.ft.**

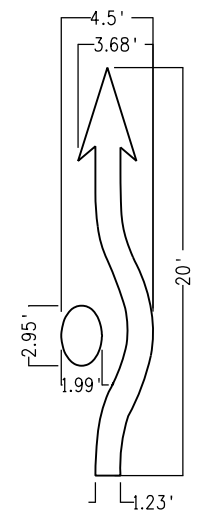

**Area = 30.6 sq.ft.**

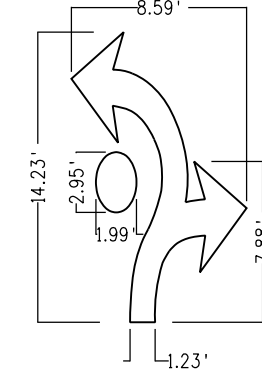

**Area = 35.3 sq.ft.**

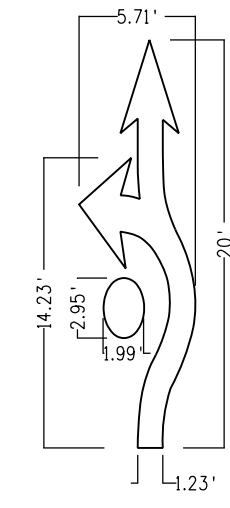

**Area = 38.3 sq.ft.**

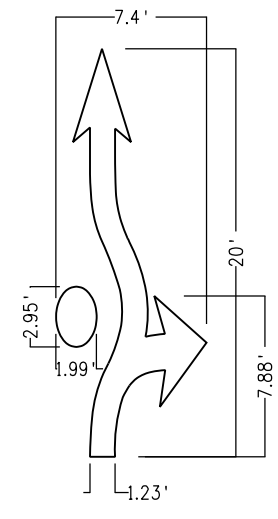

**Area = 38.1 sq.ft.**

**Word and Symbol Notes**

1. If height is increased or decreased then all measurements change proportionately  
example: "H" measurement for stop is reduced to 4 ft. from 8 ft. then square feet 5.75 (¼ of 23.0 sq. ft.).
2. Pavement word and symbol markings, transverse and longitudinal (continental) crosswalk lines, and stop lines will be paid for in square feet using their specific bid items.

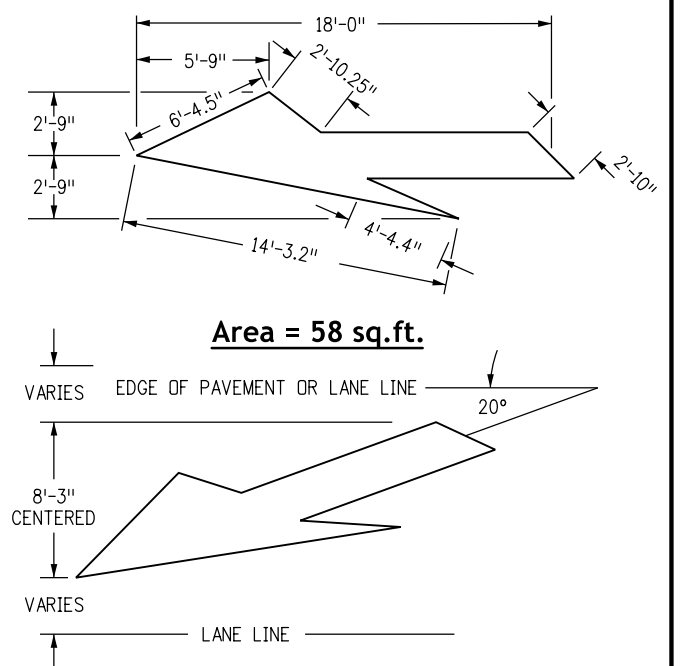

**Pavement Marking Words and Symbols (Page 2)**

Computer File Information	
Creation Date:	07/04/12
Created By:	AV
Last Modification Date:	07/01/26
Last Modified By:	NRR
CAD Ver.:	ORD 10.12 Scale: Not to Scale Units: English

Sheet Revisions	
Date:	Comments

**Colorado Department of Transportation**

**Traffic Safety & Engineering Services**

2829 West Howard Place  
Denver, CO 80204

EB

**Pavement Markings**

Issued by the Traffic Safety & Engineering Services: July 01, 2026

Standard Plan No.
<b>S-627-1</b>
Standard Sheet No. 10 of 11
Project Sheet Number:

**Elongated Interstate Route Shields**

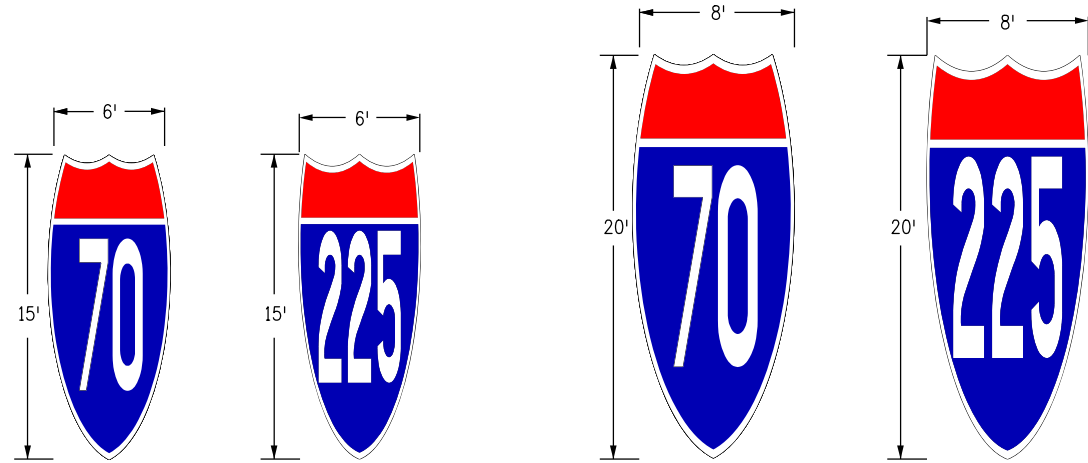

**Late/Zipper Merge**

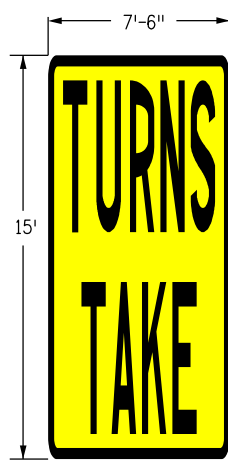

Area = 112.5 sq.ft.

**Designated Payment Areas**

For the following route shields & cardinal directions dimensions pay:

<u>Interstate</u>	
6' X 15' - 75 sq.ft.	8' X 20' - 128 sq.ft.
<u>Colorado State</u>	
6' X 15' - 90 sq.ft.	8' X 20' - 160 sq.ft.
<u>US Highways</u>	
7' X 16' - 112 sq.ft.	9' X 21' - 189 sq.ft.
<u>Cardinal</u>	
8' X 10' - 80 sq.ft.	9' X 10' - 90 sq.ft.

**Notes**

- Dimensions
  - Elongated route shields shall be at least 8'x20' when used on high speed roadways (55 mph or more).
  - Elongated route shield colors shall conform with the Standard Highway Signs and Markings book.
- Cardinal Directions
  - Use cardinal directions with white on blue when using interstate route shields.
  - Use cardinal directions with black on white when using either Colorado State or US highway route shields.
  - Cardinal direction marking word symbol from Sheet 9 of 11 may be used instead of plaque.

**Elongated Colorado State Route Shields**

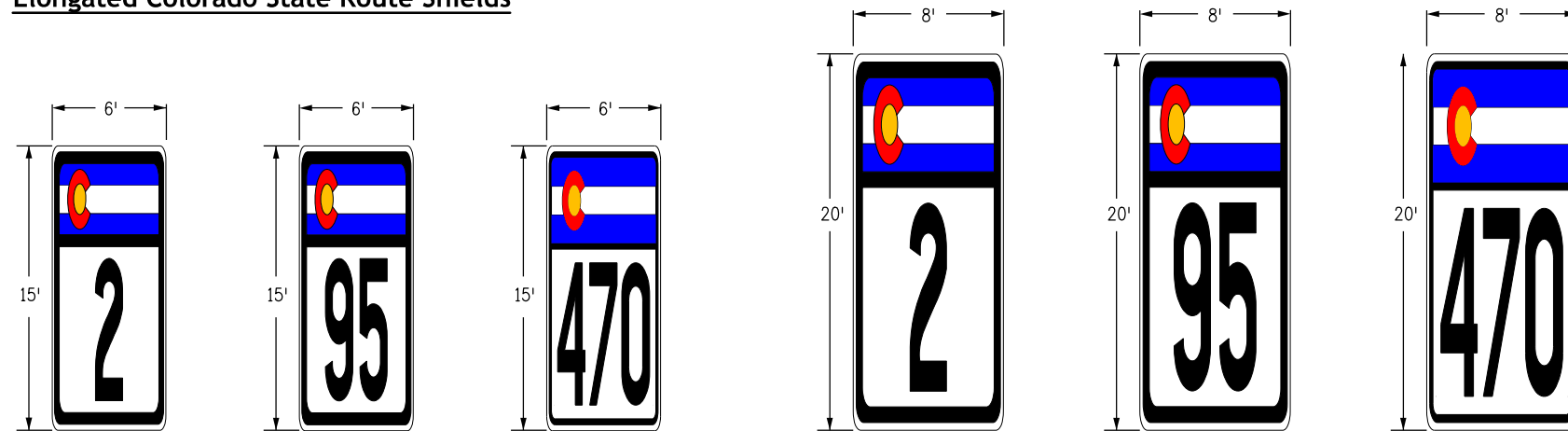

**Cardinal Directions  
(White Lettering on Blue Background)**

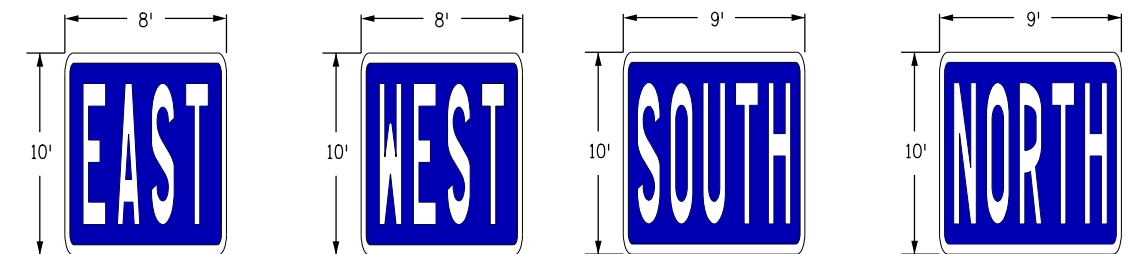

**Elongated US Highway Route Shields**

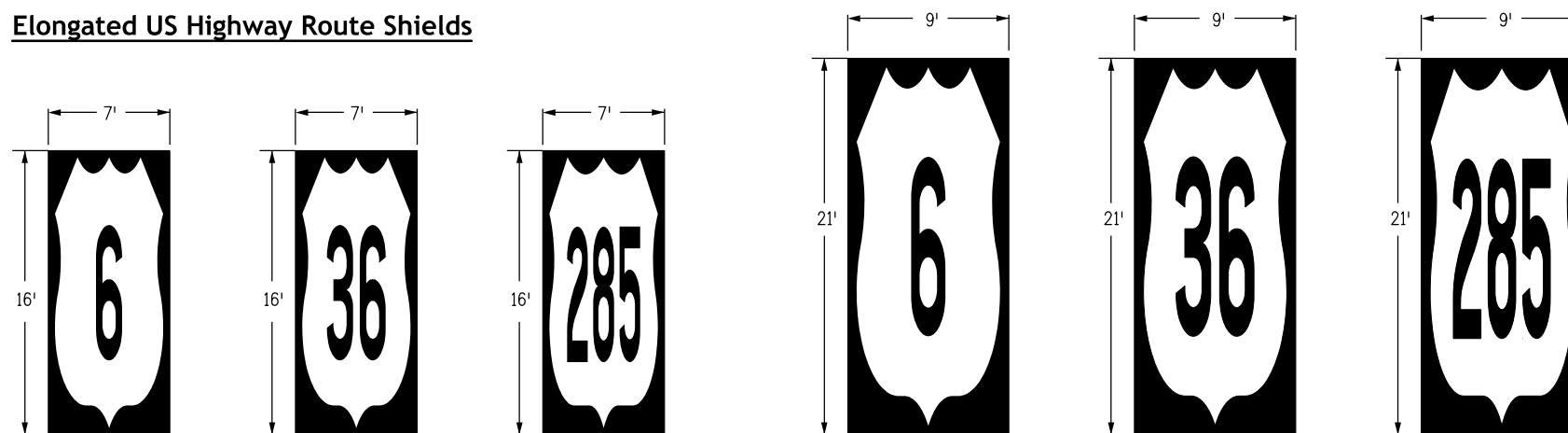

**Cardinal Directions  
(Black Lettering on White Background with Black Border)**

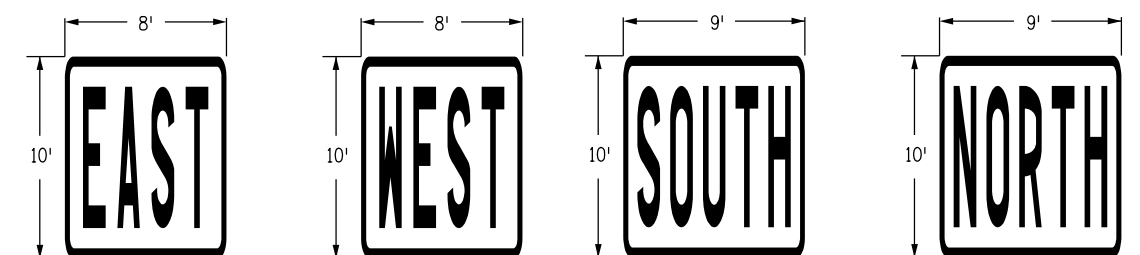

**Elongated Route Shields & Cardinal Direction Markings**

<b>Computer File Information</b>		<b>Sheet Revisions</b>		<b>Colorado Department of Transportation</b>  <b>Traffic Safety &amp; Engineering Services</b> 2829 West Howard Place Denver, CO 80204 EB	<h1>Pavement Markings</h1>	<b>Standard Plan No.</b>	
Creation Date: 07/04/12		Date:	Comments			S-627-1	
Created By: AV						Standard Sheet No. 11 of 11	
Last Modification Date: 07/01/26							
Last Modified By: NRR							
CAD Ver.: ORD 10.12 Scale: Not to Scale Units: English				Project Sheet Number:			