

Colorado Procedure 67-08

Standard Method of Test for

Determining Adhesion of Joint Sealant to Concrete Pavement

1. SCOPE

- 1.1 This procedure is designed to test the adhesion of the joint filler to the concrete pavement in sawed joints or routed cracks where backer rod is used.

2. TERMINOLOGY

- 2.1 *Adhesion* - The molecular attraction exerted between the surfaces of two different materials in contact (ie. joint sealant and concrete surface).
- 2.2 *Cohesion* - The molecular attraction exerted between adjacent molecules of a single material (i.e. The joint sealant's ability to stay together by its own properties).

METHOD A: NON-SELF-LEVELING SEALANT

3. APPARATUS

- 3.1 Pulling hook conforming to Figure 67-1. The hook shall be made of a metal rod smaller than the joint width with a ninety (90) degree bend. The tip of the hook portion shall be flattened as shown in Figure 67-1, and the width shall be 1/16 inch (2 mm) less than the width of the sawed joint.

Note 1: M Standards show both 3/16" (4.8 mm) and 1/4" (6.4 mm) joint widths depending on location.

- 3.2 A spring scale capable of attachment to the pulling hook with a minimum capacity of 25 pounds (11.4 kg).

4. TEST CONDITIONS

- 4.1 Joint sealer shall have been in place for a minimum of ten (10) days prior to performing the pull test.
- 4.2 Weather conditions: Ambient temperature shall be at a minimum 70°F (21°C).

5. PROCEDURE

- 5.1 Embed hook into joint sealant as shown in Figure 67-2.
- 5.2 The tip of the pulling hook shall be embedded under the joint sealant a distance of 1-½ inches (38 mm), to bend.

- 5.3 Attach spring scale to the handle of the pulling hook and pull vertically (steady pull, no jerking motion). The rate of pulling from the initial 0 pounds to twenty (20) pounds (90 N) is to be applied over 3 to 5 seconds.
- 5.4 When spring scale reaches 20 pounds (90 N), then hold for a minimum of one second.
- 5.5 If material fails in cohesion (tears) before reaching the 20 pound (90 N) force, without loss of adhesion to the sidewall, the application is acceptable. (NOTE: This is often the case with silicone joint sealers.)
- 5.6 If joint sealer pulls away from the sidewall prior to the 20 pound (90 N) applied force, the joint sealing application is considered failing.

6. FREQUENCY

- 6.1 If a failing joint is discovered, the tester shall isolate the failing area by testing all adjacent joints locations until passing joints are located.
- 6.2 Joints failing the pull test (CP 67 Method A) shall be removed, cleaned, and replaced at no additional cost to the project. Any joint that fails the pull test (CP 67 Method A) shall be removed the full width of the pavement or longitudinally between transverse joints.

FIGURE 67-1

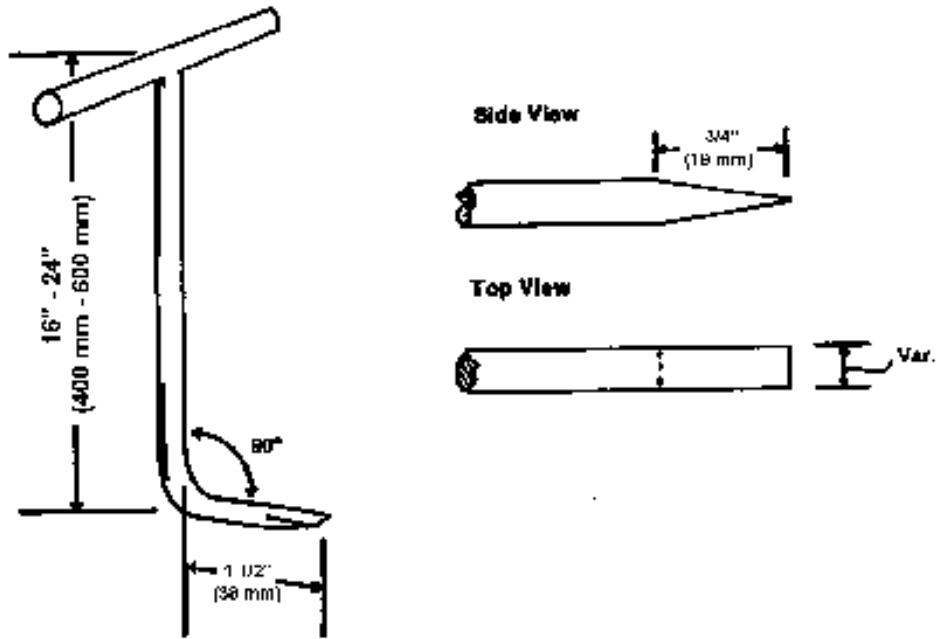
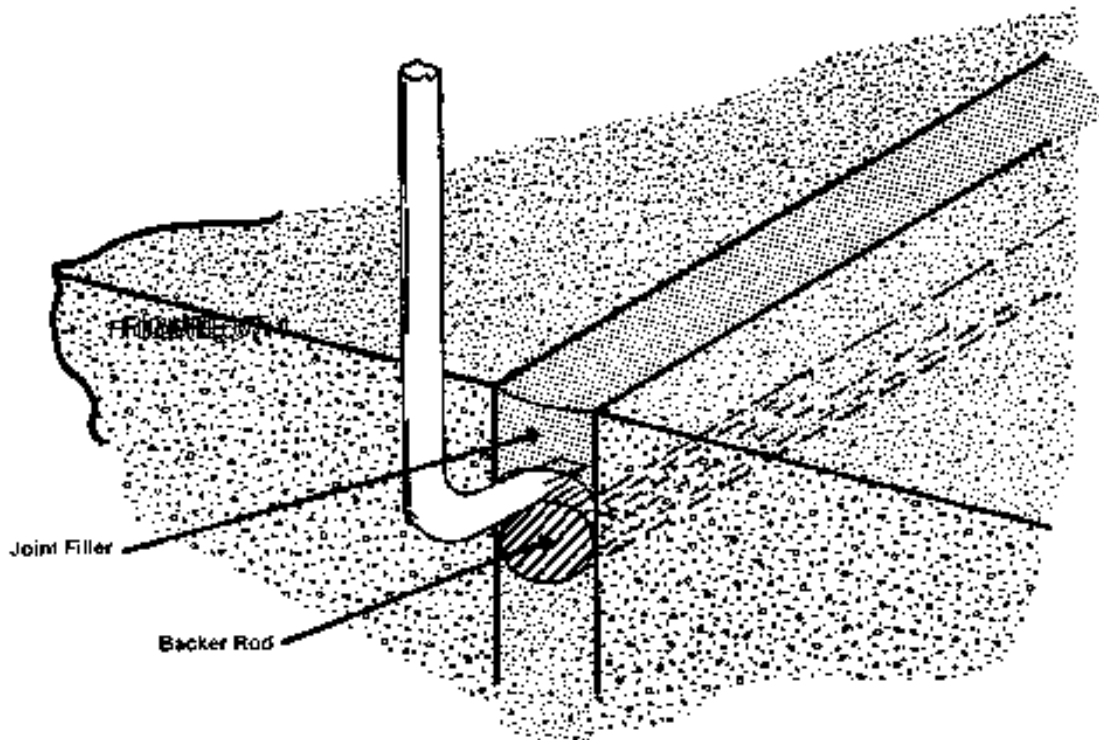

FIGURE 67-2



METHOD B: SELF- LEVELING SEALANT**7. APPARATUS**

- 7.1 A sharp knife with a minimum 2" smooth blade such as a folding pocket knife. (Many knives are available, an example: Gerber Gator 3-1/8" blade, blade thickness .100")

Note 2: M Standards show both 3/16" (4.8 mm) and 1/4" (6.4 mm) joint widths depending on location.

8. TEST CONDITIONS

- 8.1 Joint sealant shall be fully cured (this is usually within 14 to 21 days of placement).
- 8.2 Weather conditions: The test shall be conducted at any ambient temperature.

9. PROCEDURE

- 9.1 Make a knife cut horizontally from one side of the joint to the other. (See Figure 67-3)
- 9.2 Make two vertical cuts approximately 2 inches long, at the sides of the joint, meeting the horizontal cut at the top of the two-inch cuts. (See Figure 67-3)
- 9.3 Make a 1" mark on the sealant tab (in the middle of the 2" piece cut in Subsection 9.2).
- 9.4 Grasp the two-inch piece of sealant (above the 1" mark) firmly between the fingers and pull at a 90 degree angle. (See Figure 67-5) Hold a ruler alongside the extending sealant. (See Figure 67-4) Try to pull the uncut sealant out of the joints.
- 9.5 If the 1" mark can be pulled 3 inches prior to tearing, the test is successful.
- 9.6 If adhesion is proper, the sealant should tear cohesively in itself before releasing adhesively from the substrate.

10. FREQUENCY

- 10.1 If a failing joint is discovered, the tester shall isolate the failing area by testing all adjacent joint locations until passing joints are located.
- 10.2 Joints failing the pull test (CP 67 Method B) shall be removed, cleaned, and replaced at no additional cost to the project. Any joint that fails the hand pull test (CP 67 Method B) shall be removed the full width of the pavement or longitudinally between transverse joints.

11. TROUBLESHOOTING

- 11.1 Adhesion may be adversely affected by:
1. Moisture in or on the substance during sealant application and cure.
 2. Contaminated or weak surfaces.
 3. Poor application technique.

12. REPAIR OF TEST AREA

- 12.1 Sealant may be replaced in the test area in the same manner it was originally installed (assuming good adhesion was obtained). Care should be taken to assure that the new sealant is in contact with the original, and that the original sealant surfaces are clean, so that a good bond between the new and old sealant will be obtained.

13. REPORT

- 13.1 Document on CDOT Form 389.

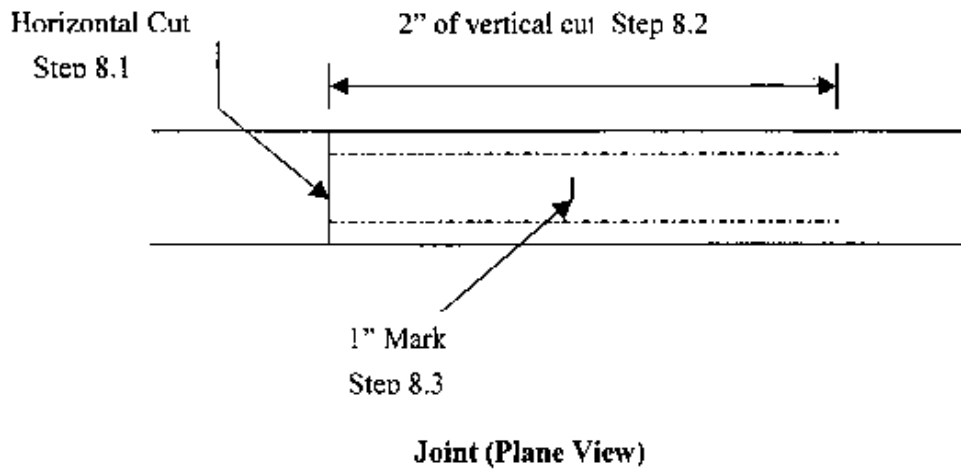

FIGURE 67-3 Joint Test preparation

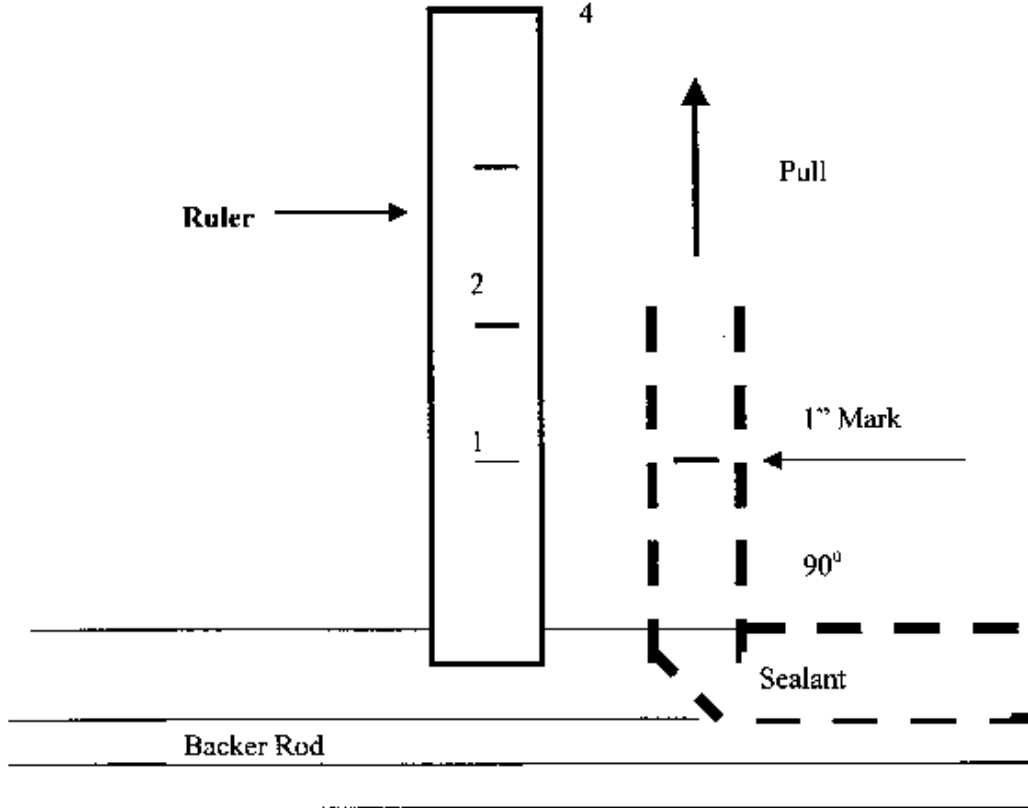

FIGURE 67-4 Pull Initiation

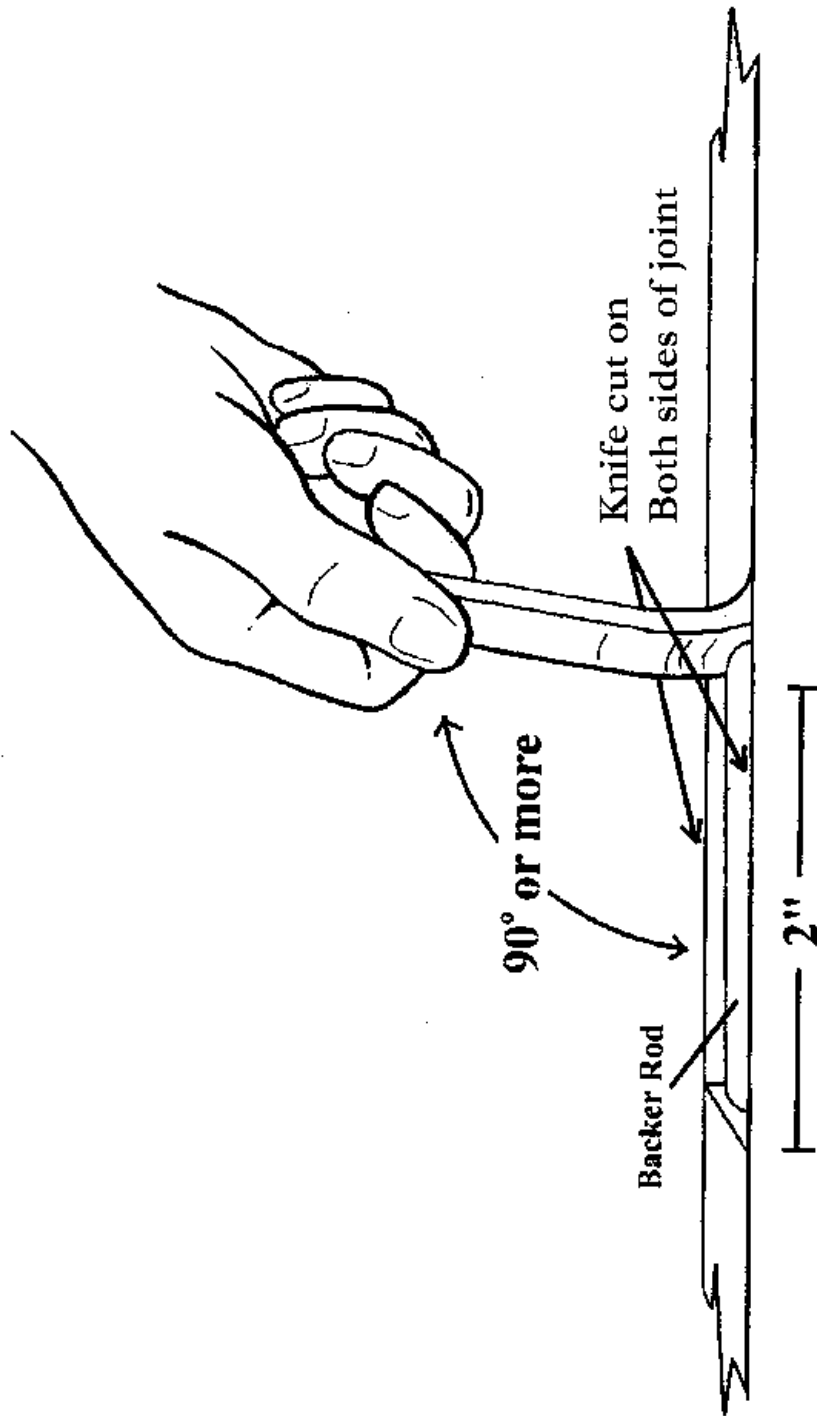

FIGURE 67-5

{Page Intentionally Left blank}